

FEATURES

- *Guaranteed* Reset Assertion at $V_{CC} = 1V$
- 1.5mA Maximum Supply Current
- Fast (35ns Maximum) Onboard Gating of RAM Chip Enable Signals
- 4.40V Precision Voltage Monitor
- Power OK/Reset Time Delay: 200ms or Adjustable
- Minimum External Component Count
- 1 μ A Maximum Standby Current
- Voltage Monitor for Power-Fail or Low Battery Warning
- Thermal Limiting
- Performance Specified Over Temperature
- Superior Upgrade for MAX690 Family
- SO8 and SO16 Packaging

APPLICATIONS

- Critical μ P Power Monitoring
- Intelligent Instruments
- Battery-Powered Computers and Controllers
- Automotive Systems

DESCRIPTION

The LTC[®]692/LTC693 provide complete power supply monitoring and battery control functions for microprocessor reset, battery backup, CMOS RAM write protection, power failure warning and watchdog timing. A precise internal voltage reference and comparator circuit monitor the power supply line. When an out-of-tolerance condition occurs, the reset outputs are forced to active states and the chip enable output unconditionally write-protects external memory. In addition, the RESET output is guaranteed to remain logic low even with V_{CC} as low as 1V.

The LTC692/LTC693 power the active CMOS RAMs with a charge-pumped NMOS power switch to achieve low drop-out and low supply current. When primary power is lost, auxiliary power, connected to the battery input pin, powers the RAMs in standby through an efficient PMOS switch.

For an early warning of impending power failure, the LTC692/LTC693 provide an internal comparator with a user-defined threshold. An internal watchdog timer is also available, which forces the reset pins to active states when the watchdog input is not toggled prior to a preset timeout period.

LT, LT, LTC, LTM, Linear Technology and the Linear logo are registered trademarks of Linear Technology Corporation. All other trademarks are the property of their respective owners.

TYPICAL APPLICATION

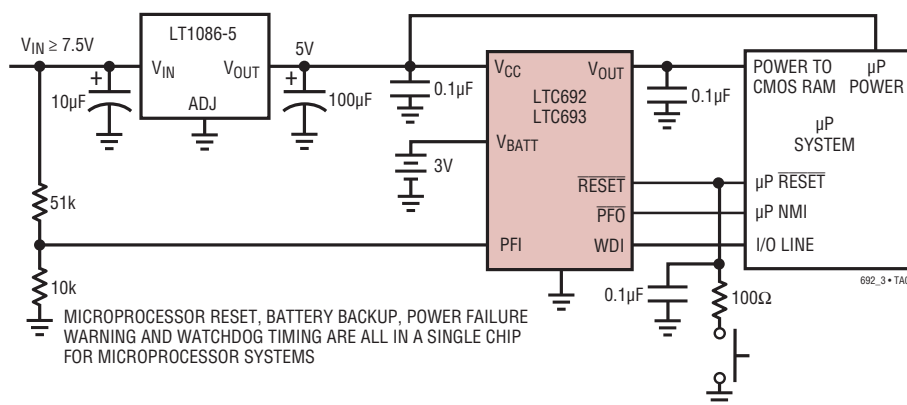

RESET Output Voltage vs Supply Voltage

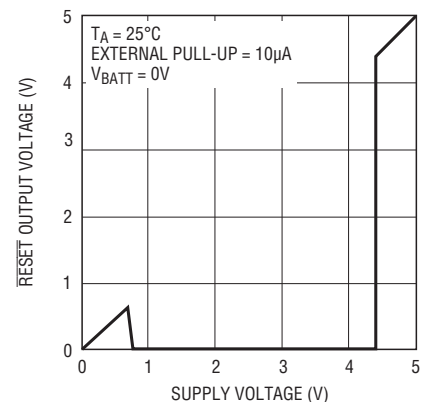

692_3 • TA01

0692fb

LTC692/LTC693

ABSOLUTE MAXIMUM RATINGS (Notes 1, 2)

Terminal Voltage	V_{OUT} Output Current	Short-Circuit Protected
V_{CC}	Power Dissipation	500mW
V_{BATT}	Operating Temperature Range	
All Other Inputs	LTC692C/LTC693C	0°C to 70°C
Input Current	LTC692I	-40°C to 85°C
V_{CC}	Storage Temperature Range	-65°C to 150°C
V_{BATT}	Lead Temperature (Soldering, 10 sec)	300°C
GND		

PIN CONFIGURATION



ORDER INFORMATION

LEAD FREE FINISH	TAPE AND REEL	PART MARKING	PACKAGE DESCRIPTION	TEMPERATURE RANGE
LTC692CN8#PBF	LTC692CN8#TRPBF	LTC692CN8	8-Lead Plastic DIP	0°C to 70°C
LTC692CS8#PBF	LTC692CS8#TRPBF	692	8-Lead Plastic SO	0°C to 70°C
LTC692IS8#PBF	LTC692IS8#TRPBF	692I	8-Lead Plastic SO	-40°C to 85°C
LTC693CN#PBF	LTC693CN#TRPBF	LTC693CN	16-Lead Plastic DIP	0°C to 70°C
LTC693CS#PBF	LTC693CS#TRPBF	LTC693CS	16-Lead Plastic SO	0°C to 70°C

Consult LTC Marketing for parts specified with wider operating temperature ranges.

Consult LTC Marketing for information on non-standard lead based finish parts.

For more information on lead free part marking, go to: <http://www.linear.com/leadfree/>

For more information on tape and reel specifications, go to: <http://www.linear.com/tapeandreeel/>

PRODUCT SELECTION GUIDE

	PINS	RESET THRESHOLD (V)	WATCHDOG TIMER	BATTERY BACKUP	POWER-FAIL WARNING	RAM WRITE-PROTECT	PUSHBUTTON RESET	CONDITIONAL BATTERY BACKUP
LTC692	8	4.40	X	X	X			
LTC693	16	4.40	X	X	X	X		
LTC690	8	4.65	X	X	X			
LTC691	16	4.65	X	X	X	X		
LTC694	8	4.65	X	X	X			
LTC695	16	4.65	X	X	X	X		
LTC699	8	4.65	X					
LTC1232	8	4.37/4.62	X				X	
LTC1235	16	4.65	X	X	X	X	X	X
LTC694-3.3	8	2.90	X	X	X			
LTC695-3.3	16	2.90	X	X	X	X		

ELECTRICAL CHARACTERISTICS

The ● denotes the specifications which apply over the full operating temperature range, otherwise specifications are at $T_A = 25^\circ\text{C}$. V_{CC} = full operating range, $V_{BATT} = 2.8\text{V}$, unless otherwise noted.

PARAMETER	CONDITIONS	MIN	TYP	MAX	UNITS	
Battery Backup Switching						
Operating Voltage Range V_{CC} V_{BATT}		4.50		5.50	V	
		2.00		4.00	V	
V_{OUT} Output Voltage	$I_{OUT} = 1\text{mA}$	● $V_{CC} - 0.05$ $V_{CC} - 0.10$	$V_{CC} - 0.005$ $V_{CC} - 0.005$		V V	
	$I_{OUT} = 50\text{mA}$		$V_{CC} - 0.50$ $V_{CC} - 0.250$		V	
V_{OUT} in Battery Backup Mode	$I_{OUT} = 250\mu\text{A}$, $V_{CC} < V_{BATT}$	$V_{BATT} - 0.1$	$V_{BATT} - 0.02$		V	
Supply Current (Exclude I_{OUT})	$I_{OUT} \leq 50\text{mA}$	●	0.6 0.6	1.5 2.5	mA mA	
Supply Current in Battery Backup Mode	$V_{CC} = 0\text{V}$, $V_{BATT} = 2.8\text{V}$	●	0.04 0.04	1 5	μA μA	
Battery Standby Current (+ = Discharge, - = Charge)	$5.5\text{V} > V_{CC} > V_{BATT} + 0.2\text{V}$	●	-0.1	0.02	μA	
		●	-1.0	0.10	μA	
Battery Switchover Threshold $V_{CC} - V_{BATT}$	Power Up		70		mV	
	Power Down		50		mV	
Battery Switchover Hysteresis			20		mV	
BATT ON Output Voltage (Note 4)	$I_{SINK} = 3.2\text{mA}$			0.4	V	
BATT ON Output Short-Circuit Current (Note 4)	BATT ON = V_{OUT} , Sink Current BATT ON = 0V, Source Current		0.5	35	mA	
				1	25	μA
Reset and Watchdog Timer						
Reset Voltage Threshold		●	4.25	4.40	4.50	V
Reset Threshold Hysteresis				40		mV
Reset Active Time (Note 5)	OSC SEL High, $V_{CC} = 5\text{V}$	●	160	200	240	ms
		●	140	200	280	ms

ELECTRICAL CHARACTERISTICS

The ● denotes the specifications which apply over the full operating temperature range, otherwise specifications are at $T_A = 25^\circ\text{C}$. V_{CC} = full operating range, $V_{BATT} = 2.8\text{V}$, unless otherwise noted.

PARAMETER	CONDITIONS		MIN	TYP	MAX	UNITS
Watchdog Timeout Period, Internal Oscillator	Long Period, $V_{CC} = 5\text{V}$	●	1.2 1.0	1.6 1.6	2.00 2.25	sec sec
	Short Period, $V_{CC} = 5\text{V}$	●	80 70	100 100	120 140	ms ms
Watchdog Timeout Period, External Clock (Note 6)	Long Period		4032		4097	Clock Cycles
	Short Period		960		1025	
Reset Active Time PSRR				1		ms/V
Watchdog Timeout Period PSRR, Internal OSC				1		ms/V
Minimum WDI Input Pulse Width	$V_{IL} = 0.4\text{V}$, $V_{IH} = 3.5\text{V}$	●	200			ns
RESET Output Voltage at $V_{CC} = 1\text{V}$	$I_{SINK} = 10\mu\text{A}$, $V_{CC} = 1\text{V}$			4	200	mV
RESET and LOW LINE Output Voltage (Note 4)	$I_{SINK} = 1.6\text{mA}$, $V_{CC} = 4.25\text{V}$ $I_{SOURCE} = 1\mu\text{A}$, $V_{CC} = 5\text{V}$		3.5		0.4	V V
RESET and WDO Output Voltage (Note 4)	$I_{SINK} = 1.6\text{mA}$, $V_{CC} = 5\text{V}$ $I_{SOURCE} = 1\mu\text{A}$, $V_{CC} = 4.25\text{V}$		3.5		0.4	V V
RESET, RESET, WDO, LOW LINE Output Short-Circuit Current (Note 4)	Output Source Current Output Sink Current		1	3 25	25	μA mA
WDI Input Threshold	Logic Low Logic High		3.5		0.8	V V
WDI Input Current	$WDI = V_{OUT}$ $WDI = 0\text{V}$	● ●	-50	4 -8	50	μA μA
Power-Fail Detector						
PFI Input Threshold	$V_{CC} = 5\text{V}$	●	1.25	1.3	1.35	V
PFI Input Threshold PSRR				0.3		mV/V
PFI Input Current				± 0.01	± 25	nA
PFO Output Voltage (Note 4)	$I_{SINK} = 3.2\text{mA}$ $I_{SOURCE} = 1\mu\text{A}$		3.5		0.4	V V
PFO Short-Circuit Source Current (Note 4)	PFI = High, PFO = 0V PFI = Low, PFO = VOUT		1	3 25	25	μA mA
PFI Comparator Response Time (Falling)	$\Delta V_{IN} = -20\text{mV}$, $V_{OD} = 15\text{mV}$			2		μs
PFI Comparator Response Time (Rising) (Note 4)	$\Delta V_{IN} = 20\text{mV}$, $V_{OD} = 15\text{mV}$ with 10k Ω Pull-Up			40 8		μs μs
Chip Enable Gating						
CE IN Threshold	V_{IL} V_{IH}		2.0		0.8	V V
CE IN Pull-Up Current (Note 7)				3		μA
CE OUT Output Voltage	$I_{SINK} = 3.2\text{mA}$ $I_{SOURCE} = 3\text{mA}$ $I_{SOURCE} = 1\mu\text{A}$, $V_{CC} = 0\text{V}$		$V_{OUT} - 1.50$ $V_{OUT} - 0.05$		0.4	V V V
CE Propagation Delay	$V_{CC} = 5\text{V}$, $C_L = 20\text{pF}$	●		20 20	35 45	ns ns
CE OUT Output Short-Circuit Current	Output Source Current Output Sink Current			30 35		mA mA

ELECTRICAL CHARACTERISTICS

The ● denotes the specifications which apply over the full operating temperature range, otherwise specifications are at $T_A = 25^\circ\text{C}$. V_{CC} = full operating range, $V_{BATT} = 2.8\text{V}$, unless otherwise noted.

PARAMETER	CONDITIONS	MIN	TYP	MAX	UNITS
Oscillator					
OSC IN Input Current (Note 7)			±2		μA
OSC SEL Input Pull-Up Current (Note 7)			5		μA
OSC IN Frequency Range	OSC SEL = 0V	● 0		250	kHz
OSC IN Frequency with External Capacitor	OSC SEL = 0V, $C_{OSC} = 47\text{pF}$		4		kHz

Note 1: Stresses beyond those listed under Absolute Maximum Ratings may cause permanent damage to the device. Exposure to any Absolute Maximum Rating condition for extended periods may affect device reliability and lifetime.

Note 2: All voltage values are with respect to GND.

Note 3: For military temperature range, consult the factory.

Note 4: The output pins of $\overline{\text{BATT ON}}$, $\overline{\text{LOW LINE}}$, $\overline{\text{PFO}}$, $\overline{\text{WDO}}$, $\overline{\text{RESET}}$ and $\overline{\text{RESET}}$ have weak internal pull-ups of typically 3μA. However, external pull-up resistors may be used when higher speed is required.

Note 5: The LTC692/LTC693 have minimum reset active times of 140ms (200ms typically). The reset active time of the LTC693 can be adjusted (see Table 2 in Applications Information Section).

Note 6: The external clock feeding into the circuit passes through the oscillator before clocking the watchdog timer (see Block Diagram). Variation in the timeout period is caused by phase errors which occur when the oscillator divides the external clock by 64. The resulting variation in the timeout period is 64 clocks plus one clock of jitter.

Note 7: The input pins of $\overline{\text{CE IN}}$, OSC IN and OSC SEL have weak internal pull-ups which pull to the supply when the input pins are floating.

TYPICAL PERFORMANCE CHARACTERISTICS

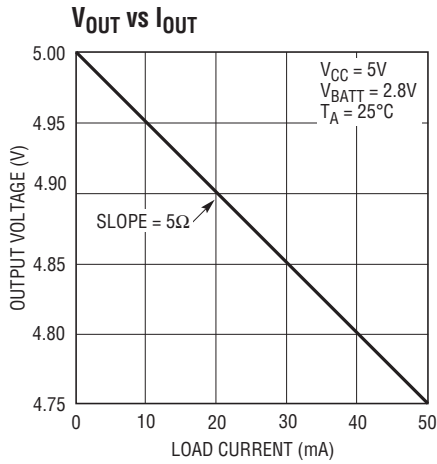

692_3 • TPC01

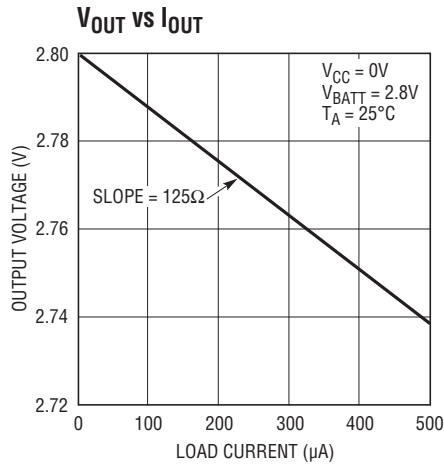

692_3 • TPC02

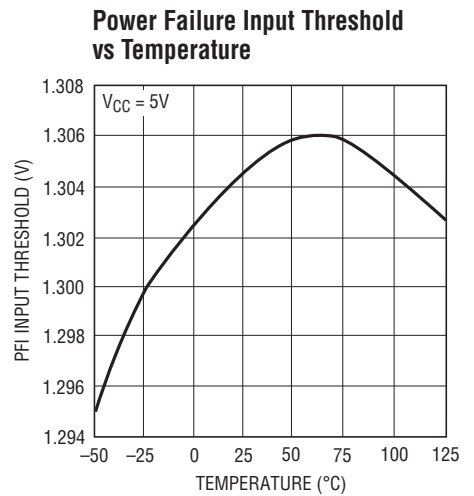

692_3 • TPC03

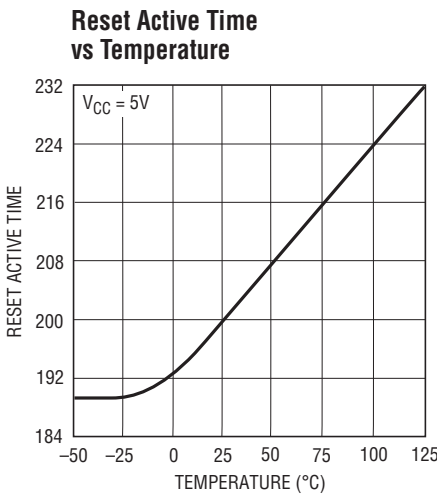

692_3 • TPC04

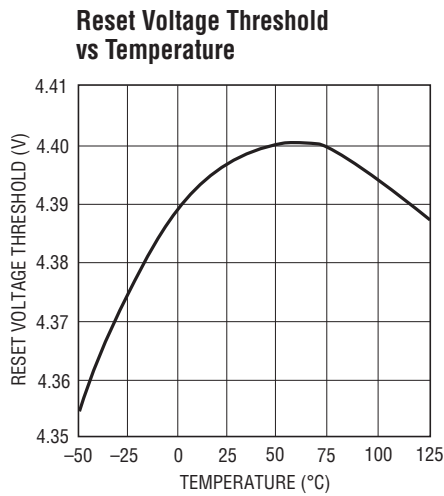

692_3 • TPC05

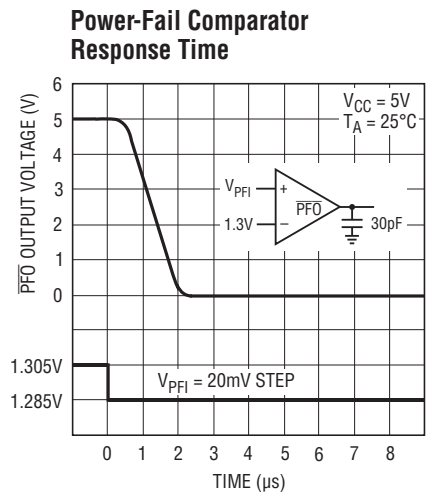

692_3 • TPC06

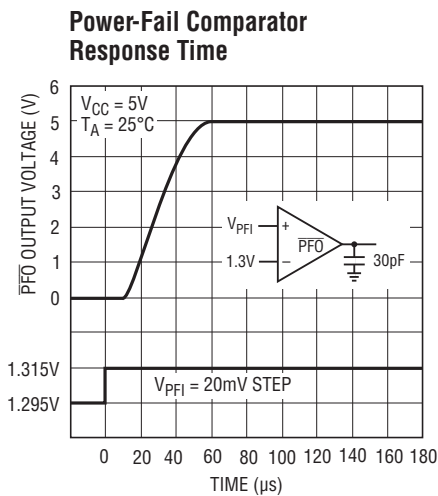

692_3 • TPC07

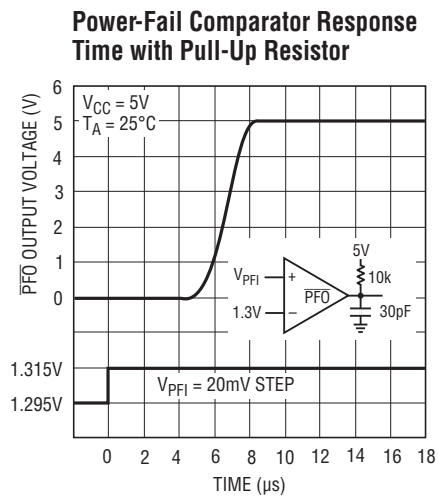

692_3 • TPC08

PIN FUNCTIONS

BATT ON: Battery On Logic Output from Comparator C2. BATT ON goes low when V_{OUT} is internally connected to V_{CC} . The output typically sinks 35mA and can provide base drive for an external PNP transistor to increase the output current above the 50mA rating of V_{OUT} . BATT ON goes high when V_{OUT} is internally switched to V_{BATT} .

\overline{CE} IN: Logic Input to the \overline{Chip} Enable Gating Circuit. \overline{CE} IN can be derived from microprocessor's address line and/or decoder output. See Applications Information section and Figure 5 for additional information.

\overline{CE} OUT: Logic Output on the \overline{Chip} Enable Gating Circuit. When V_{CC} is above the reset voltage threshold, \overline{CE} OUT is a buffered replica of \overline{CE} IN. When V_{CC} is below the reset voltage threshold \overline{CE} OUT is forced high (see Figure 5).

GND: Ground Pin.

\overline{LOW} LINE: Logic Output from Comparator C1. \overline{LOW} LINE indicates a low line condition at the V_{CC} input. When V_{CC} falls below the reset voltage threshold (4.40V typically), \overline{LOW} LINE goes low. As soon as V_{CC} rises above the reset voltage threshold, \overline{LOW} LINE returns high (see Figure 1). \overline{LOW} LINE goes low when V_{CC} drops below V_{BATT} (see Table 1).

OSC IN: Oscillator Input. OSC IN can be driven by an external clock signal or an external capacitor can be connected between OSC IN and GND when OSC SEL is forced low. In this configuration the nominal reset active time and watchdog timeout period are determined by the number of clocks or set by the formula (see Applications Information section). When OSC SEL is high or floating, the internal oscillator is enabled and the reset active time is fixed at 200ms typical. OSC IN selects between the 1.6 seconds and 100ms typical watchdog timeout periods. In both cases the timeout period immediately after a reset is 1.6 seconds typical.

OSC SEL: Oscillator Selection Input. When OSC SEL is high or floating, the internal oscillator sets the reset active time and watchdog timeout period. Forcing OSC SEL low allows OSC IN to be driven from an external clock signal or an external capacitor to be connected between OSC IN and GND.

PFI: Power Failure Input. PFI is the noninverting input to the power-fail comparator, C3. The inverting input is internally connected to a 1.3V reference. The power failure output remains high when PFI is above 1.3V and goes low when PFI is below 1.3V. Connect PFI to GND or V_{OUT} when C3 is not used.

\overline{PFO} : Power Failure Output from C3. \overline{PFO} remains high when PFI is above 1.3V and goes low when PFI is below 1.3V. When V_{CC} is lower than V_{BATT} , C3 is shut down and \overline{PFO} is forced low.

\overline{RESET} : Logic Output for μ P Reset Control. Whenever V_{CC} falls below either the reset voltage threshold (4.40V typically) or V_{BATT} , \overline{RESET} goes active low. After V_{CC} returns to 5V, reset pulse generator forces \overline{RESET} to remain active low for a minimum of 140ms. When the watchdog timer is enabled but not serviced prior to a preset timeout period, reset pulse generator also forces \overline{RESET} to active low for a minimum of 140ms for every preset timeout period (see Figure 11). The reset active time is adjustable on the LTC693. An external pushbutton reset can be used in connection with the \overline{RESET} output. See Pushbutton Reset in the Applications Information section.

RESET: RESET is an Active High Logic Output. It is the inverse of \overline{RESET} .

V_{BATT} : Backup Battery Input. When V_{CC} falls below V_{BATT} , auxiliary power connected to V_{BATT} is delivered to V_{OUT} through PMOS switch, M2. If backup battery or auxiliary power is not used, V_{BATT} should be connected to GND.

V_{CC} : 5V Supply Input. The V_{CC} pin should be bypassed with a 0.1 μ F capacitor.

V_{OUT} : Voltage Output for Backed-Up Memory. Bypass with a capacitor of 0.1 μ F or greater. During normal operation, V_{OUT} obtains power from V_{CC} through an NMOS power switch, M1, which can deliver up to 50mA and has a typical on-resistance of 5 Ω . When V_{CC} is lower than V_{BATT} , V_{OUT} is internally switched to V_{BATT} . If V_{OUT} and V_{BATT} are not used, connect V_{OUT} to V_{CC} .

PIN FUNCTIONS

WDI: Watchdog Input. WDI is a three level input. Driving WDI either high or low for longer than the watchdog timeout period, forces both $\overline{\text{RESET}}$ and $\overline{\text{WDO}}$ low. Floating WDI disables the watchdog timer. The timer resets itself with each transition of the watchdog input (see Figure 11).

$\overline{\text{WDO}}$: Watchdog Logic Output. When the watchdog input remains either high or low for longer than the watchdog timeout period, $\overline{\text{WDO}}$ goes low. $\overline{\text{WDO}}$ is set high whenever there is a transition on the WDI pin, or $\overline{\text{LOW LINE}}$ goes low. The watchdog timer can be disabled by floating WDI (see Figure 11).

BLOCK DIAGRAM

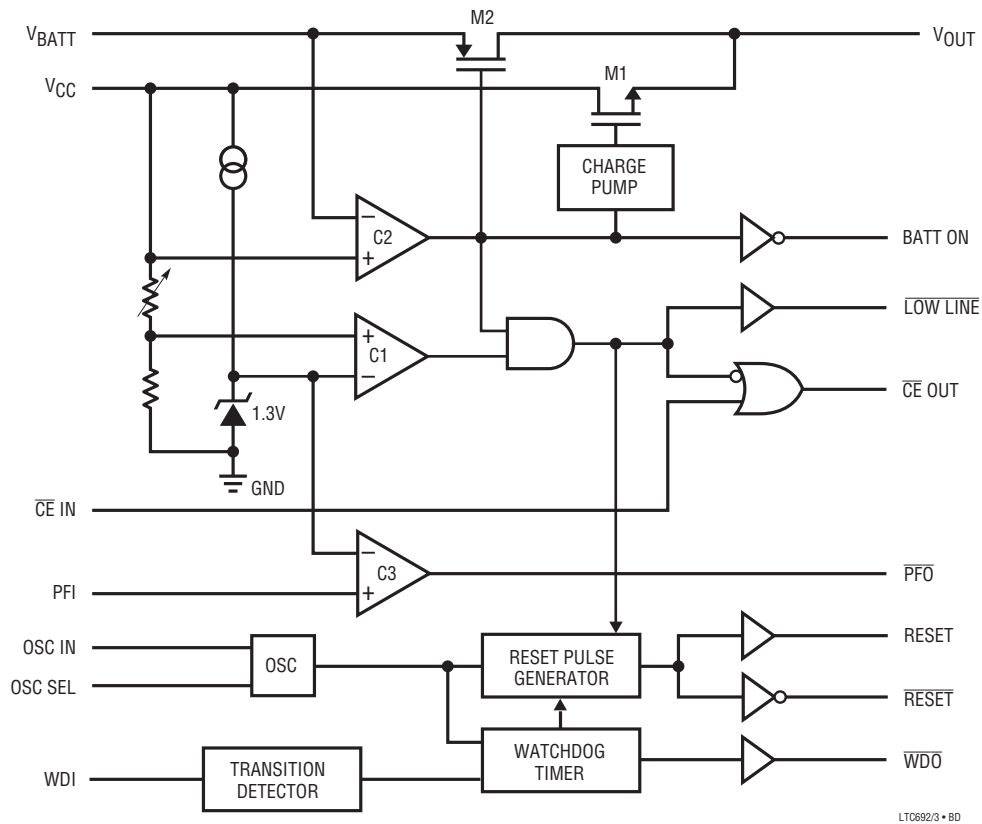

LTC692/3 • 80

APPLICATIONS INFORMATION

Microprocessor Reset

The LTC692/LTC693 use a bandgap voltage reference and a precision voltage comparator C1 to monitor the 5V supply input on V_{CC} (see Block Diagram). When V_{CC} falls below the reset voltage threshold, the $\overline{\text{RESET}}$ output is forced to active low state. The reset voltage threshold accounts for a 10% variation on V_{CC} , so the $\overline{\text{RESET}}$ output becomes active low when V_{CC} falls below 4.50V (4.40V typical). On power-up, the $\overline{\text{RESET}}$ signal is held active low for a minimum of 140ms after reset voltage threshold is reached to allow the power supply and microprocessor to stabilize. The reset active time is adjustable on the LTC693. On power down, the $\overline{\text{RESET}}$ signal remains active low even with V_{CC} as low as 1V. This capability helps hold the microprocessor in stable shutdown condition. Figure 1 shows the timing diagram of the $\overline{\text{RESET}}$ signal.

The precision voltage comparator, C1, typically has 40mV of hysteresis which ensures that glitches at the V_{CC} pin do not activate the $\overline{\text{RESET}}$ output. Response time is typically 10 μ s. To help prevent mistriggering due to transient loads, V_{CC} pin should be bypassed with a 0.1 μ F capacitor with the leads trimmed as short as possible.

The LTC693 has two additional outputs: $\overline{\text{RESET}}$ and $\overline{\text{LOW LINE}}$. $\overline{\text{RESET}}$ is an active high output and is the inverse of $\overline{\text{RESET}}$. $\overline{\text{LOW LINE}}$ is the output of the precision voltage comparator, C1. When V_{CC} falls below the reset voltage threshold, $\overline{\text{LOW LINE}}$ goes low. $\overline{\text{LOW LINE}}$ returns high as soon as V_{CC} rises above the reset voltage threshold.

Battery Switchover

The battery switchover circuit compares V_{CC} to the V_{BATT} input, and connects V_{OUT} to whichever is higher. When V_{CC} rises to 70mV above V_{BATT} , the battery switchover comparator, C2, connects V_{OUT} to V_{CC} through a charge pumped NMOS power switch, M1. When V_{CC} falls to 50mV above V_{BATT} , C2 connects V_{OUT} to V_{BATT} through a PMOS switch, M2. C2 has typically 20mV of hysteresis to prevent spurious switching when V_{CC} remains nearly equal to V_{BATT} . The response time of C2 is approximately 20 μ s.

During normal operation, the LTC692/LTC693 use a charge pumped NMOS power switch to achieve low dropout and low supply current. This power switch can deliver up to 50mA to V_{OUT} from V_{CC} and has a typical on-resistance of 5 Ω . The V_{OUT} pin should be bypassed with a capacitor of 0.1 μ F or greater to ensure stability. Use of a larger bypass capacitor is advantageous for supplying current to heavy transient loads.

When operating currents larger than 50mA are required from V_{OUT} , or a lower dropout ($V_{CC} - V_{\text{OUT}}$ voltage differential) is desired, the LTC693 should be used. This product provides BATT ON output to drive the base of the external PNP transistor (Figure 2). If higher currents are needed with the LTC692, a high current Schottky diode can be connected from the V_{CC} pin to the V_{OUT} pin to supply the extra current.

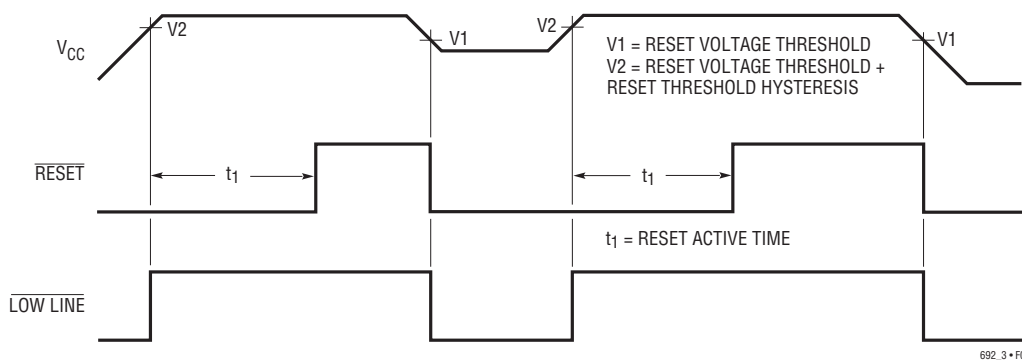

Figure 1. Reset Active Time

APPLICATIONS INFORMATION

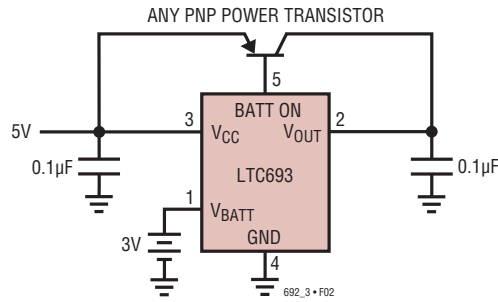

Figure 2. Using BATT ON to Drive External PNP Transistor

The LTC692/LTC693 are protected for safe area operation with a short-circuit limit. Output current is limited to approximately 200mA. If the device is overloaded for long periods of time, thermal shutdown turns the power switch off until the device cools down. The threshold temperature for thermal shutdown is approximately 155°C with about 10°C of hysteresis which prevents the device from oscillating in and out of shutdown.

The PNP switch used in competitive devices was not chosen for the internal power switch because it injects unwanted current into the substrate. This current is collected by the V_{BATT} pin in competitive devices and adds to the charging current of the battery which can damage lithium batteries. The LTC692/LTC693 use a charge-pumped NMOS power switch to eliminate unwanted charging current while achieving low dropout and low supply current. Since no current goes to the substrate, the current collected by the V_{BATT} pin is strictly junction leakage.

A 125Ω PMOS switch connects the V_{BATT} input to V_{OUT} in battery backup mode. The switch is designed for very low dropout voltage (input-to-output differential). This feature is advantageous for low current applications such as battery backup in CMOS RAM and other low power CMOS circuitry. The supply current in battery backup mode is 1µA maximum.

The operating voltage at the V_{BATT} pin ranges from 2.0V to 4.0V. High value capacitors, such as electrolytic or farad-size double layer capacitors, can be used for short-term

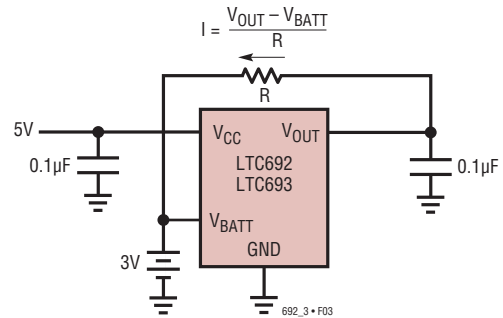
Figure 3. Charging External Battery Through V_{OUT}

memory backup instead of a battery. The charging resistor for the rechargeable batteries should be connected to V_{OUT} since this eliminates the discharge path that exists when the resistor is connected to V_{CC} (Figure 3).

Replacing the Backup Battery

When changing the backup battery with system power on, spurious resets can occur while the battery is removed due to battery standby current. Although battery standby current is only a tiny leakage current, it can still charge up the stray capacitance on the V_{BATT} pin. The oscillation cycle is as follows: When V_{BATT} reaches within 50mV of V_{CC} , the LTC692/LTC693 switch to battery backup. V_{OUT} pulls V_{BATT} low and the devices go back to normal operation. The leakage current then charges up the V_{BATT} pin again and the cycle repeats.

If spurious resets during battery replacement pose no problems, then no action is required. Otherwise, a resistor from V_{BATT} to GND will hold the pin low while changing the battery. For example, the battery standby current is 1µA maximum over temperature and the external resistor required to hold V_{BATT} below V_{CC} is:

$$R \leq \frac{V_{CC} - 50\text{mV}}{1\mu\text{A}}$$

With $V_{CC} = 4.25\text{V}$, a 3.9M resistor will work. With a 3V battery, this resistor will draw only 0.77µA from the battery, which is negligible in most cases.

APPLICATIONS INFORMATION

If battery connections are made through long wires, a 10Ω to 100Ω series resistor and a $0.1\mu\text{F}$ capacitor are recommended to prevent any overshoot beyond V_{CC} due to the lead inductance (Figure 4).

Table 1 shows the state of each pin during battery backup. When the battery switchover section is not used, connect V_{BATT} to GND and V_{OUT} to V_{CC} .

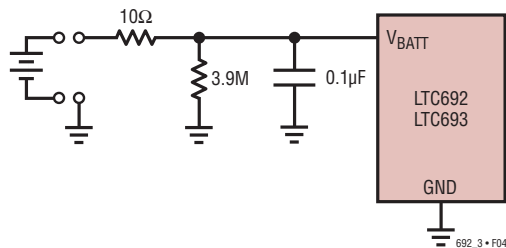

Figure 4. $10\Omega/0.1\mu\text{F}$ Combination Eliminates Inductive Overshoot and Prevents Spurious Resets During Battery Replacement

Memory Protection

The LTC693 includes memory protection circuitry which ensures the integrity of the data in memory by preventing write operations when V_{CC} is at an invalid level. Two additional pins, $\overline{\text{CE IN}}$ and $\overline{\text{CE OUT}}$, control the Chip Enable or Write inputs of CMOS RAM. When V_{CC} is 5V, $\overline{\text{CE OUT}}$ follows $\overline{\text{CE IN}}$ with a typical propagation delay of 20ns. When V_{CC} falls below the reset voltage threshold or V_{BATT} , $\overline{\text{CE OUT}}$ is forced high, independent of $\overline{\text{CE IN}}$. $\overline{\text{CE OUT}}$ is an alternative signal to drive the $\overline{\text{CE}}$, $\overline{\text{CS}}$, or $\overline{\text{Write}}$ input of

Table 1. Input and Output Status in Battery Backup Mode

SIGNAL	STATUS
V_{CC}	C2 monitors V_{CC} for active switchover
V_{OUT}	V_{OUT} is connected to V_{BATT} through an internal PMOS switch
V_{BATT}	The supply current is $1\mu\text{A}$ maximum
BATT ON	Logic high. The open-circuit output voltage is equal to V_{OUT}
PFI	Power failure input is ignored
$\overline{\text{PFO}}$	Logic low
RESET	Logic low
RESET	Logic high. The open-circuit output voltage is equal to V_{OUT}
$\overline{\text{LOW LINE}}$	Logic low
WDI	Watchdog input is ignored
$\overline{\text{WDO}}$	Logic high. The open-circuit output voltage is equal to V_{OUT}
$\overline{\text{CE IN}}$	Chip Enable input is ignored
$\overline{\text{CE OUT}}$	Logic high. The open-circuit output voltage is equal to V_{OUT}
OSC IN	OSC IN is ignored
OSC SEL	OSC SEL is ignored

battery backed up CMOS RAM. $\overline{\text{CE OUT}}$ can also be used to drive the Store or Write input of an EEPROM, EAPROM or NOVRAM to achieve similar protection. Figure 5 shows the timing diagram of $\overline{\text{CE IN}}$ and $\overline{\text{CE OUT}}$.

$\overline{\text{CE IN}}$ can be derived from the microprocessor's address decoder output. Figure 6 shows a typical nonvolatile CMOS RAM application.

Memory protection can also be achieved with the LTC692 by using RESET as shown in Figure 7.

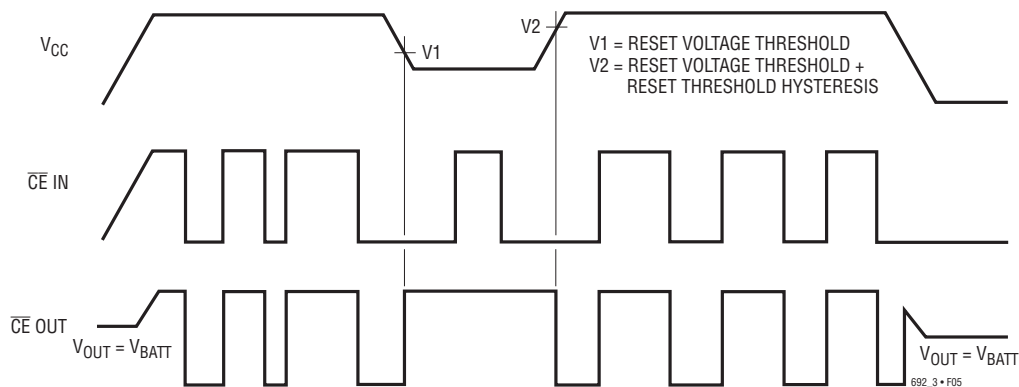

Figure 5. Timing Diagram for $\overline{\text{CE IN}}$ and $\overline{\text{CE OUT}}$

APPLICATIONS INFORMATION

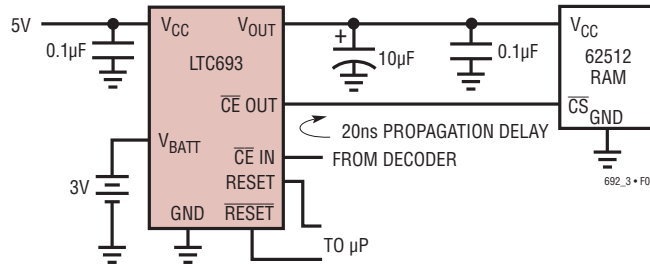

Figure 6. A Typical Nonvolatile CMOS RAM Application

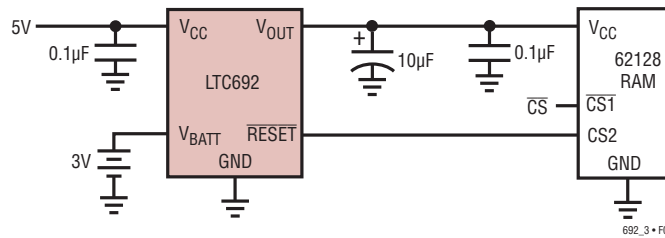

Figure 7. Write-Protect for RAM with the LTC692

Power-Fail Warning

The LTC692/LTC693 generate a power failure output ($\overline{\text{PFO}}$) for early warning of failure in the microprocessor's power supply. This is accomplished by comparing the power failure input (PFI) with an internal 1.3V reference. $\overline{\text{PFO}}$ goes low when the voltage at the PFI pin is less than 1.3V. Typically PFI is driven by an external voltage divider (R1 and R2 in Figures 8 and 9) which senses either an unregulated DC input or a regulated 5V output. The voltage divider ratio can be chosen such that the voltage at the PFI pin falls below 1.3V, several milliseconds before the 5V supply falls below the maximum reset voltage threshold of 4.50V. $\overline{\text{PFO}}$ is normally used to interrupt the microprocessor to execute shutdown procedure between $\overline{\text{PFO}}$ and $\overline{\text{RESET}}$ or RESET.

The power-fail comparator, C3, does not have hysteresis. Hysteresis can be added however, by connecting a resistor between the $\overline{\text{PFO}}$ output and the noninverting PFI input pin as shown in Figures 8 and 9. The upper and lower trip points in the comparator are established as follows:

When $\overline{\text{PFO}}$ output is low, R3 sinks current from the summing junction at the PFI pin.

$$V_H = 1.3V \left(1 + \frac{R1}{R2} + \frac{R1}{R3} \right)$$

When $\overline{\text{PFO}}$ output is high, the series combination of R3 and R4 source current into the PFI summing junction.

$$V_L = 1.3V \left(1 + \frac{R1}{R2} - \frac{(5V - 1.3V)R1}{1.3V(R3 + R4)} \right)$$

$$\text{Assuming } R4 \ll R3, V_{\text{HYSTERESIS}} = 5V \frac{R1}{R3}$$

APPLICATIONS INFORMATION

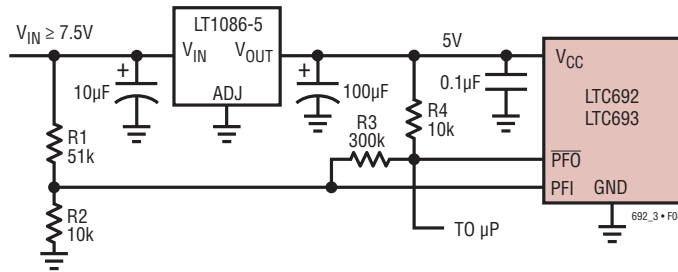

Figure 8. Monitoring *Unregulated* DC Supply with the LTC692/LTC693 Power-Fail Comparator

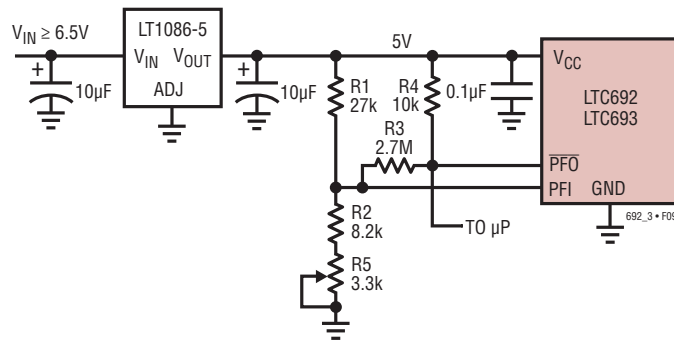

Figure 9. Monitoring *Regulated* DC Supply with the LTC692/LTC693 Power-Fail Comparator

Example 1: The circuit in Figure 8 demonstrates the use of the power-fail comparator to monitor the unregulated power supply input. Assuming the rate of decay of the supply input V_{IN} is 100mV/ms and the total time to execute a shutdown procedure is 8ms. Also, the noise of V_{IN} is 200mV. With these assumptions in mind, we can reasonably set $V_L = 7.25V$ which is 1.25V greater than the sum of maximum reset voltage threshold and the dropout voltage of LT[®]1086-5 (4.5V + 1.5V) and $V_{HYSTERESIS} = 850mV$.

$$V_{HYSTERESIS} = 5V \frac{R1}{R3} = 850mV$$

$$R3 \approx 5.88 R1$$

Choose $R3 = 300k$ and $R1 = 51k$. Also select $R4 = 10k$ which is much smaller than $R3$.

$$7.25V = 1.3V \left(1 + \frac{51k}{R2} - \frac{(5V - 1.3V)51k}{1.3V(310k)} \right)$$

$R2 = 10.1k$, Choose nearest 5% resistor 10k and recalculate V_L ,

$$V_L = 1.3V \left(1 + \frac{51k}{10k} - \frac{(5V - 1.3V)51k}{1.3V(310k)} \right) = 7.32V$$

$$V_H = 1.3V \left(1 + \frac{51k}{10k} + \frac{51k}{300k} \right) = 8.151V$$

$$\frac{(7.32V - 6.25V)}{100mV/ms} = 10.7ms$$

$$V_{HYSTERESIS} = 8.151V - 7.32V = 831mV$$

The 10.7ms allows enough time to execute shutdown procedure for microprocessor and 831mV of hysteresis would prevent PFO from going low due to the noise of V_{IN} .

APPLICATIONS INFORMATION

Example 2: The circuit in Figure 9 can be used to measure the regulated 5V supply to provide early warning of power failure. Because of variations in the PFI threshold, this circuit requires adjustment to ensure the PFI comparator trips before the reset threshold is reached. Adjust R5 such that the $\overline{\text{PFO}}$ output goes low when the V_{CC} supply reaches the desired level (e.g., 4.6V).

Monitoring the Status of the Battery

C3 can also monitor the status of the memory backup battery (Figure 10). If desired, the $\overline{\text{CE OUT}}$ can be used to apply a test load to the battery. Since $\overline{\text{CE OUT}}$ is forced high in battery backup mode, the test load will not be applied to the battery while it is in use, even if the microprocessor is not powered.

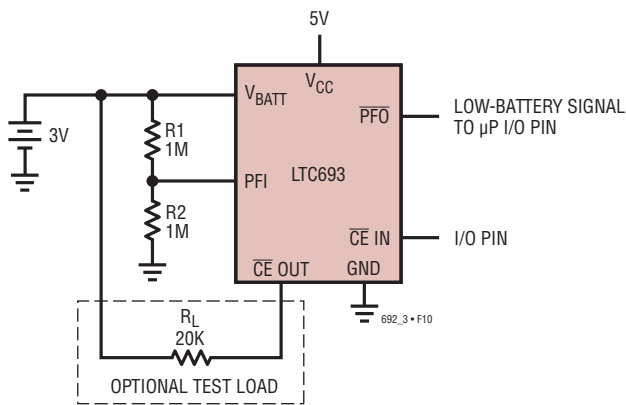

Figure 10. Backup Battery Monitor with Optional Test Load

Watchdog Timer

The LTC692/LTC693 provide a watchdog timer function to monitor the activity of the microprocessor. If the microprocessor does not toggle the watchdog input (WDI) within a selected timeout period, $\overline{\text{RESET}}$ is forced to active low for a minimum of 140ms. The reset active time is adjustable on the LTC693. Since many systems cannot service the watchdog timer immediately after a reset, the LTC693 has longer timeout period (1.0 second minimum) right after a reset is issued. The normal timeout period (70ms minimum) becomes effective following the first transition of WDI after $\overline{\text{RESET}}$ is inactive. The watchdog timeout period is fixed at a 1.0 second minimum on the LTC692. Figure 11 shows the timing diagram of watchdog timeout period and reset active time. The watchdog timeout period is restarted as soon as $\overline{\text{RESET}}$ is inactive. When either a high-to-low or low-to-high transition occurs at the WDI pin prior to timeout, the watchdog timer is reset and begins to timeout again. To ensure the watchdog timer does not timeout, either a high-to-low or low-to-high transition on the WDI pin must occur at or less than the minimum timeout period. If the input to the WDI pin remains either high or low, reset pulses will be issued every 1.6 seconds typically. The watchdog timer can be deactivated by floating the WDI pin. The timer is also disabled when V_{CC} falls below the reset voltage threshold or V_{BATT} .

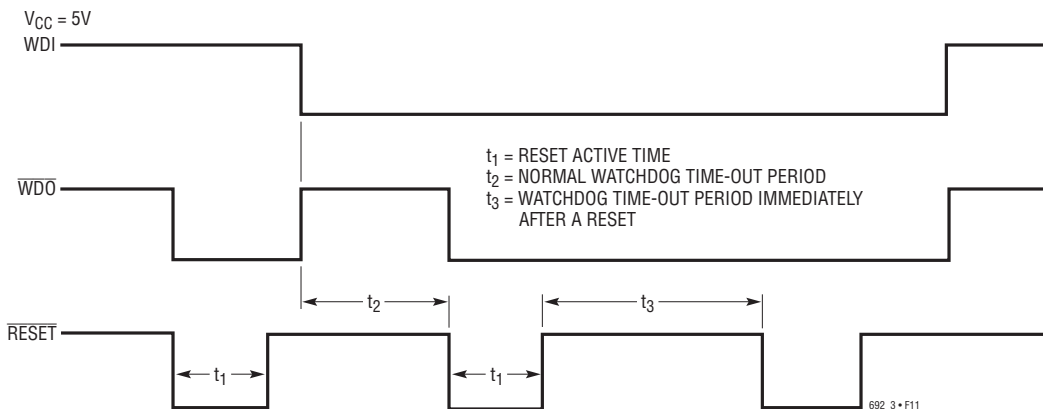

Figure 11. Watchdog Timeout Period and Reset Active Time

APPLICATIONS INFORMATION

The LTC693 provides an additional output (watchdog output, \overline{WDO}) which goes low if the watchdog timer is allowed to time out and remains low until set high by the next transition on the WDI pin. \overline{WDO} is also set high when V_{CC} falls below the reset voltage threshold or V_{BATT} .

The LTC693 has two additional pins OSC SEL and OSC IN, which allow reset active time and watchdog timeout period to be adjusted per Table 2. Several configurations are shown in Figure 12.

OSC IN can be driven by an external clock signal or an external capacitor can be connected between OSC IN and

GND when OSC SEL is forced low. In these configurations, the nominal reset active time and watchdog timeout period are determined by the number of clocks or set by the formula in Table 2. When OSC SEL is high or floating, the internal oscillator is enabled and the reset active time is fixed at 140ms minimum. OSC IN selects between the 1 second and 70ms minimum normal watchdog timeout periods. In both cases, the timeout period immediately after a reset is at least 1 second.

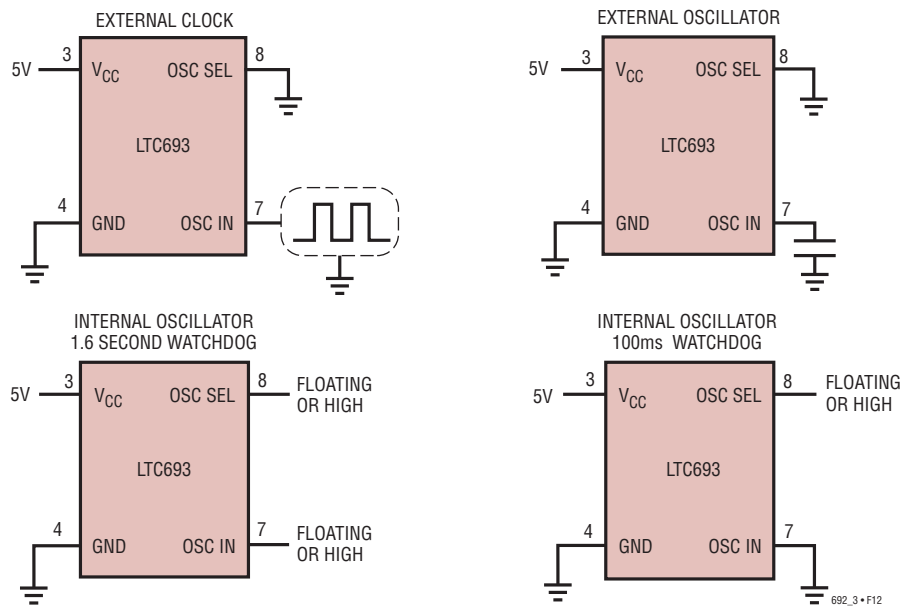

Figure 12. Oscillator Configurations

Table 2. LTC693 Reset Active Time and Watchdog Timeout Selections

OSC SEL	OSC IN	WATCHDOG TIMEOUT PERIOD		RESET ACTIVE TIME
		NORMAL (SHORT PERIOD)	IMMEDIATELY AFTER RESET (LONG PERIOD)	LTC693
Low	External Clock Input	1024 clks	4096 clks	2048 clks
Low	External Capacitor*	$\frac{400\text{ms}}{47\text{pF}} \times C$	$\frac{1.6\text{ sec}}{47\text{pF}} \times C$	$\frac{800\text{ms}}{47\text{pF}} \times C$
Floating or High	Low	100ms	1.6 sec	200ms
Floating or High	Floating or High	1.6 sec	1.6 sec	200ms

*The nominal internal frequency is 10.24kHz. The nominal oscillator frequency with external capacitor is $f_{OSC} \text{ (Hz)} = \frac{184,000}{C \text{ (pF)}}$

APPLICATIONS INFORMATION

Pushbutton Reset

The LTC692/LTC693 do not provide a logic input for direct connection to a pushbutton. However, a pushbutton in series with a 100Ω resistor connected to the $\overline{\text{RESET}}$ output pin (Figure 13) provides an alternative for manual reset. Connecting a 0.1μF capacitor to the $\overline{\text{RESET}}$ pin debounces the pushbutton input.

The 100Ω resistor in series with the pushbutton is required to prevent the ringing, due to the capacitance and lead inductance, from pulling the $\overline{\text{RESET}}$ pins of the MPU and LTC692/LT693 below ground.

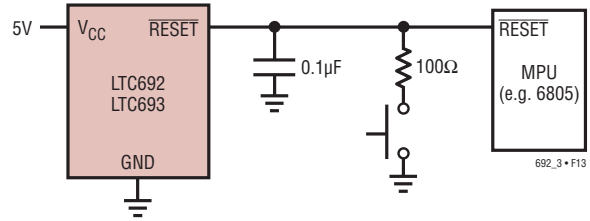
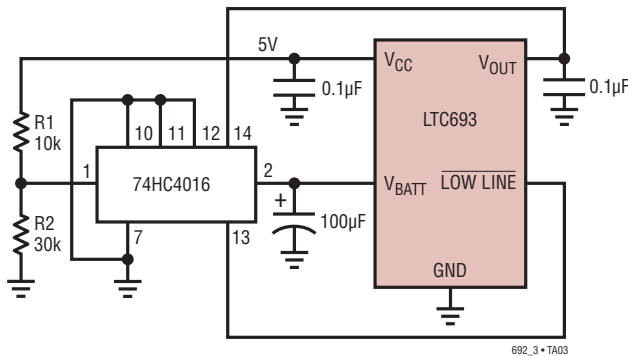

Figure 13. The External Pushbutton Reset

TYPICAL APPLICATIONS

Capacitor Backup with 74HC4016 Switch



Write-Protect for Additional RAMs

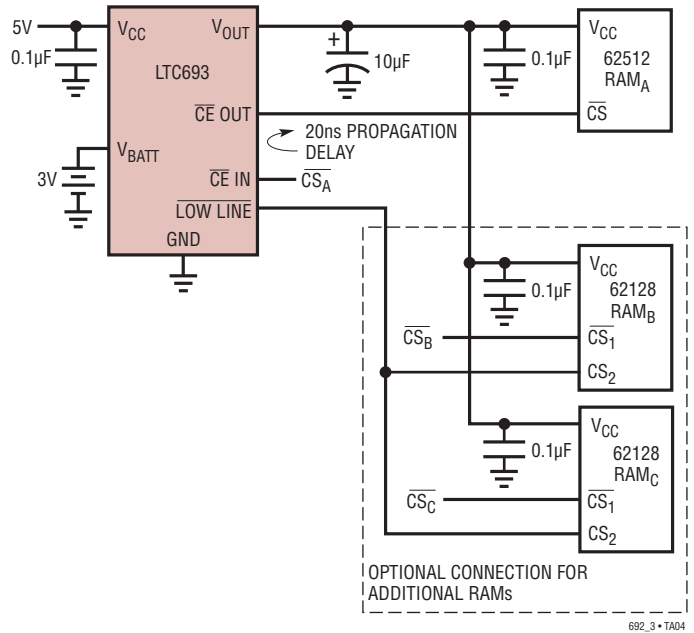

OPTIONAL CONNECTION FOR ADDITIONAL RAMS

PACKAGE DESCRIPTION

N8 Package 8-Lead PDIP (Narrow .300 Inch) (Reference LTC DWG # 05-08-1510)

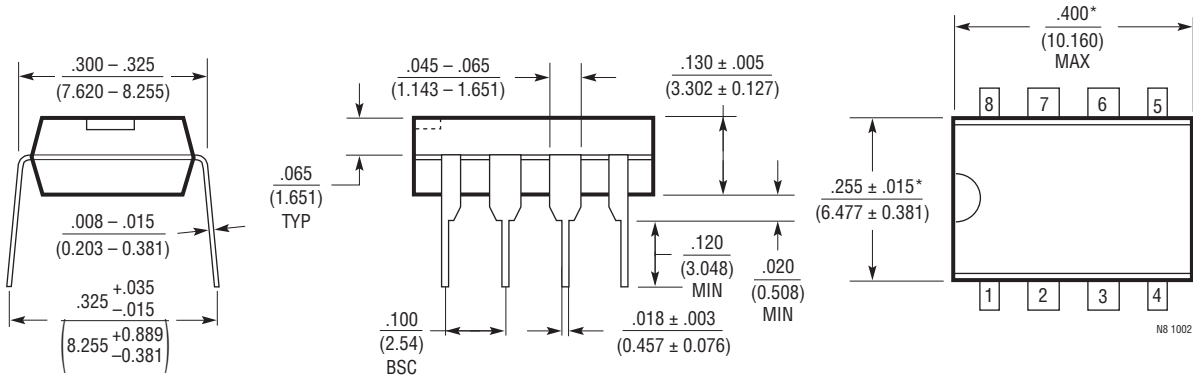

NOTE:
1. DIMENSIONS ARE $\frac{\text{INCHES}}{\text{MILLIMETERS}}$
*THESE DIMENSIONS DO NOT INCLUDE MOLD FLASH OR PROTRUSIONS.
MOLD FLASH OR PROTRUSIONS SHALL NOT EXCEED .010 INCH (0.254mm)

S8 Package 8-Lead Plastic Small Outline (Narrow .150 Inch) (Reference LTC DWG # 05-08-1610)

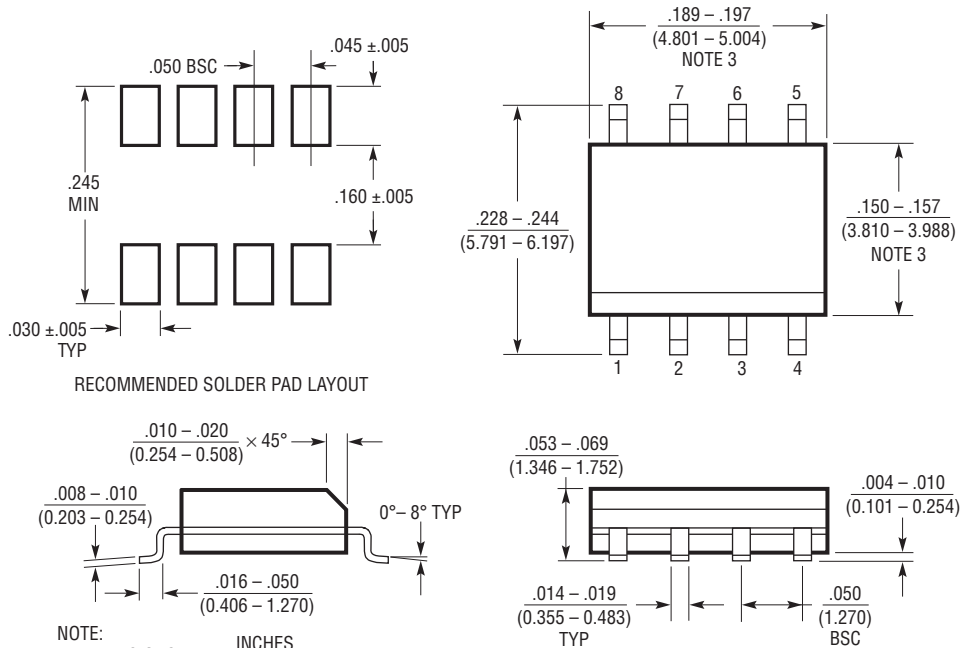

RECOMMENDED SOLDER PAD LAYOUT

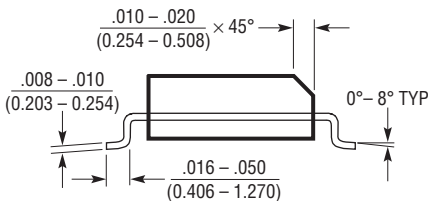

NOTE:
1. DIMENSIONS IN $\frac{\text{INCHES}}{\text{MILLIMETERS}}$
2. DRAWING NOT TO SCALE
3. THESE DIMENSIONS DO NOT INCLUDE MOLD FLASH OR PROTRUSIONS.
MOLD FLASH OR PROTRUSIONS SHALL NOT EXCEED .006" (0.15mm)

S08 0303

PACKAGE DESCRIPTION

N Package 16-Lead PDIP (Narrow .300 Inch) (Reference LTC DWG # 05-08-1510)

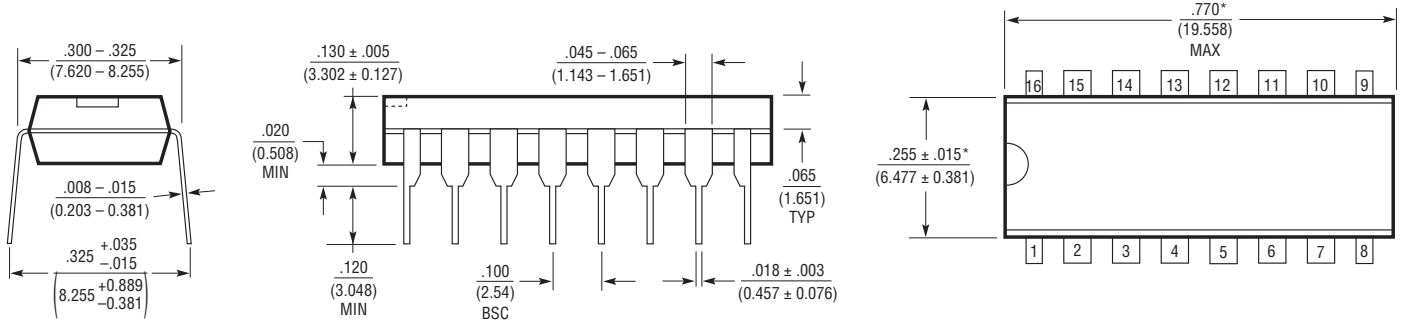

NOTE:
1. DIMENSIONS ARE $\frac{\text{INCHES}}{\text{MILLIMETERS}}$

*THESE DIMENSIONS DO NOT INCLUDE MOLD FLASH OR PROTRUSIONS.
MOLD FLASH OR PROTRUSIONS SHALL NOT EXCEED .010 INCH (0.254mm)

N16 1002

SW Package 16-Lead Plastic Small Outline (Wide .300 Inch) (Reference LTC DWG # 05-08-1620)

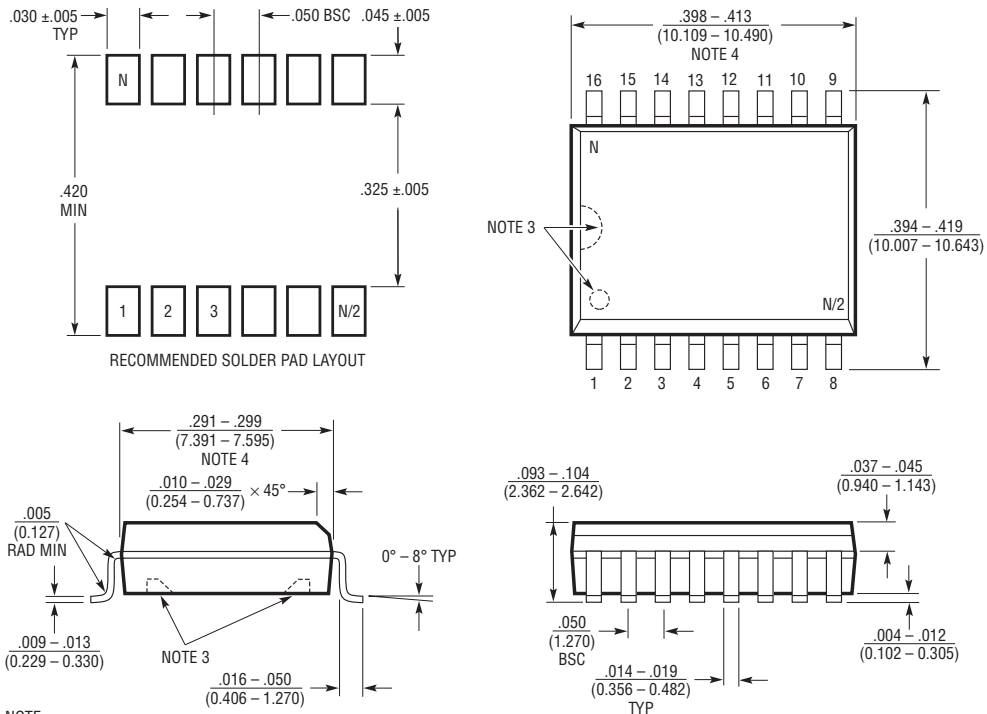

NOTE:
1. DIMENSIONS IN $\frac{\text{INCHES}}{\text{MILLIMETERS}}$
2. DRAWING NOT TO SCALE
3. PIN 1 IDENT, NOTCH ON TOP AND CAVITIES ON THE BOTTOM OF PACKAGES ARE THE MANUFACTURING OPTIONS.
THE PART MAY BE SUPPLIED WITH OR WITHOUT ANY OF THE OPTIONS
4. THESE DIMENSIONS DO NOT INCLUDE MOLD FLASH OR PROTRUSIONS.
MOLD FLASH OR PROTRUSIONS SHALL NOT EXCEED .006" (0.15mm)

S16 (WIDE) 0502

REVISION HISTORY (Revision history begins at Rev B)

REV	DATE	DESCRIPTION	PAGE NUMBER
B	03/10	Revised Features section to remove "UL Recognized" and UL logo.	1

LTC692/LTC693

RELATED PARTS

PART NUMBER	DESCRIPTION	COMMENTS
LTC690	5V Supply Monitor, Watchdog Timer and Battery Backup	4.65V Threshold
LTC694-3.3	3.3V Supply Monitor, Watchdog Timer and Battery Backup	2.9V Threshold
LTC1232	5V Supply Monitor, Watchdog Timer and Pushbutton Reset	4.37V/4.62V Threshold
LTC1326	Micropower Precision Triple Supply Monitor	4.725V, 3.118V, 1V Threshold ($\pm 0.75\%$)
LTC1536	Precision Triple Supply Monitor for PCI Applications	Meets PCI t_{FALL} Timing Specifications
LTC1726	Micropower Triple Supply Monitor for 2.5V/5V, 3.3V and ADJ	Adjustable $\overline{\text{RESET}}$ and Watchdog Timeouts
LTC1727	Micropower Triple Supply Monitor with Open-Drain Reset	Individual Monitor Outputs in MSOP
LTC1728	Micropower Triple Supply Monitor with Open-Drain Reset	5-Lead SOT-23 Package
LTC2900	Programmable Quad Supply Monitor	Adjustable $\overline{\text{RESET}}$ 10-Lead MSOP and 3mm \times 3mm 10-Lead DFN
LTC2901	Programmable Quad Supply Monitor	Adjustable $\overline{\text{RESET}}$ and Watchdog Timer, 16-Lead SSOP Package
LTC2902	Programmable Quad Supply Monitor	Adjustable $\overline{\text{RESET}}$ and Tolerance, 16-Lead SSOP Package, Margining
LTC2903	Precision Quad Supply Monitor	6-Lead SOT-23 Package, Ultralow Voltage Reset
LTC2904	3-State Programmable Precision Dual Supply Monitor	Adjustable Tolerance, 8-Lead SOT-23 Package
LTC2905	3-State Programmable Precision Dual Supply Monitor	Adjustable $\overline{\text{RESET}}$ and Tolerance, 8-Lead SOT-23 Package
LTC2906	Precision Dual Supply Monitor 1 Selectable and 1 Adjustable	Separate V_{CC} Pin, RST/ $\overline{\text{RST}}$ Outputs
LTC2907	Precision Dual Supply Monitor 1 Selectable and 1 Adjustable	Separate V_{CC} Pin, Adjustable Reset Timer
LTC2908	Precision Six Supply Monitor (Four Fixed and 2 Adjustable)	8-Lead SOT-23 and DDB Packages
LTC2909	Precision Triple/Dual Input UV, OV	2 ADJ Inputs
LTC2910	Octal Positive/Negative Voltage Monitor	16-Lead SSOP and 5mm \times 3mm DFN Packages
LTC2912	Single UV/OV Voltage Monitor, Adjustable UV and OV	8-Lead TSOT and 3mm \times 2mm DFN Packages
LTC2913	Dual UV/OV Voltage Monitor	10-Lead MSOP and 3mm \times 3mm DFN Packages
LTC2914	Qual UV/OV Positive/Negative Voltage Monitor	16-Lead SSOP and 5mm \times 3mm DFN Packages
LTC2915	Single Supervisor with 27 Selectable Thresholds	10-Lead MSOP and 3mm \times 2mm DFN-10 Packages
LTC2916	Single Supervisor with 9 Selectable Thresholds	Manual Reset, 10-Lead MSOP and 3mm \times 2mm DFN-10 Packages

0692fb