

LH0021/LH0021C 1.0 Amp Power Operational Amplifier LH0041/LH0041C 0.2 Amp Power Operational Amplifier

General Description

The LH0021/LH0021C and LH0041/LH0041C are general purpose operational amplifiers capable of delivering large output currents not usually associated with conventional IC Op Amps. The LH0021 will provide output currents in excess of one ampere at voltage levels of $\pm 12V$; the LH0041 delivers currents of 200 mA at voltage levels closely approaching the available power supplies. In addition, both the inputs and outputs are protected against overload, the devices are compensated with a single external capacitor and are free of any unusual oscillation or latch-up problems.

The excellent input characteristics and high output capability of the LH0021 make it an ideal choice for power applications such as DC servos, capstan drivers, deflection yoke drivers, and programmable power supplies.

The LH0041 is particularly suited for applications such as torque driver for inertial guidance systems, diddle yoke driver for alpha-numeric CRT displays, cable drivers, and programmable power supplies for automatic test equipment.

The LH0021 is supplied in a 8 pin TO-3 package rated at 20 watts with suitable heatsink. The LH0041 is supplied in both

12 pin TO-8 (2.5 watts with clip on heatsink) and a power 8 pin ceramic DIP (2 watts with suitable heatsink). The LH0021 and LH0041 are guaranteed over the temperature range of $-55^{\circ}C$ to $+125^{\circ}C$ while the LH0021C and LH0041C are guaranteed from $-25^{\circ}C$ to $+85^{\circ}C$.

Features

- Output current

LH0021	1.0 Amp
LH0041	0.2 Amp
- Output voltage swing

LH0021	$\pm 12V$ into 10 Ω
LH0041	$\pm 14V$ into 100 Ω
- Wide full power bandwidth 15 kHz
- Low standby power 100 mW at $\pm 15V$
- Low input offset voltage and current 1 mV and 20 nA
- High slew rate 3.0V/ μs
- High open loop gain 100 dB

Schematic Diagram

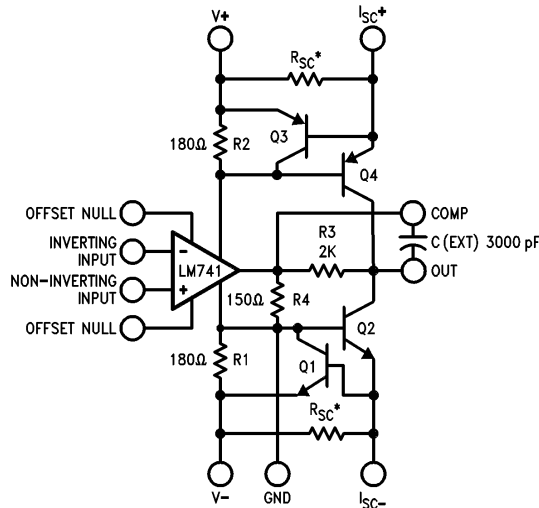

* R_{SC} external on "G" and "K" packages. R_{SC} internal on "J" package. Offset Null connections available only on "G" package.

TL/H/9298-1

LH0021/LH0021C 1.0 Amp Power Operational Amplifier
LH0041/LH0041C 0.2 Amp Power Operational Amplifier

Absolute Maximum Ratings

If Military/Aerospace specified devices are required, please contact the National Semiconductor Sales Office/Distributors for availability and specifications.

Supply Voltage	±18V
Power Dissipation	See Curves
Differential Input Voltage	±30V
Input Voltage (Note 1)	±15V
Peak Output Current (Note 2)	
LH0021/LH0021C	2.0 Amps
LH0041/LH0041C	0.5 Amps

Output Short Circuit Duration (Note 3)	Continuous
Operating Temperature Range	
LH0021/LH0041	−55°C to +125°C
LH0021C/LH0041C	−25°C to +85°C
Storage Temperature Range	−65°C to +150°C
Lead Temperature (Soldering, 10 sec.)	300°C
ESD rating to be determined.	

DC Electrical Characteristics for LH0021/LH0021C (Note 4)

Parameter	Conditions	Limits						Units
		LH0021			LH0021C			
		Min	Typ	Max	Min	Typ	Max	
Input Offset Voltage	$R_S < 100\Omega$, $T_C = 25^\circ\text{C}$ $R_S < 100\Omega$		1.0	3.0 5.0		3.0 7.5		mV mV
Voltage Drift with Temperature	$R_S < 100\Omega$		3	25		5	30	$\mu\text{V}/^\circ\text{C}$
Offset Voltage Drift with Time			5			5		$\mu\text{V}/\text{week}$
Offset Voltage Change with Output Power			5	15		5	20	$\mu\text{V}/\text{W}$
Input Offset Current	$T_C = 25^\circ\text{C}$		30	100 300		50	200 500	nA nA
Offset Current Drift with Temperature			0.1	1.0		0.2	1.0	nA/ $^\circ\text{C}$
Offset Current Drift with Time			2			2		nA/week
Input Bias Current	$T_C = 25^\circ\text{C}$		100	300 1.0		200	500 1.0	nA μA
Input Resistance	$T_C = 25^\circ\text{C}$	0.3	1.0		0.3	1.0		M Ω
Input Capacitance			3			3		pF
Common Mode Rejection Ratio	$R_S 100\Omega$, $\Delta V_{CM} = \pm 10\text{V}$	70	90		70	90		dB
Input Voltage Range	$V_S = \pm 15\text{V}$	±12			±12			V
Power Supply Rejection Ratio	$R_S \leq 100\Omega$, $\Delta V_S = \pm 10\text{V}$	80	96		70	90		dB
Voltage Gain	$V_S = \pm 15\text{V}$, $V_O = \pm 10\text{V}$ $R_L = 1\text{k}\Omega$, $T_C = 25^\circ\text{C}$ $V_S = \pm 15\text{V}$, $V_O = \pm 10\text{V}$ $R_L = 100\Omega$	100	200		100	200		V/mV V/mV
Output Voltage Swing	$V_S = \pm 15\text{V}$, $R_L = 100\Omega$ $V_S = \pm 15\text{V}$, $R_L = 10\Omega$, $T_C = 25^\circ\text{C}$	±13.5 ±11.0	14 ±12		±13 ±10	±14 ±12		V V
Output Short Circuit Current	$V_S = \pm 15\text{V}$, $T_C = 25^\circ\text{C}$, $R_{SC} = 0.5\Omega$	0.8	1.2	1.6	0.8	1.2	1.6	Amps
Power Supply Current	$V_S = \pm 15\text{V}$, $V_{OUT} = 0$		2.5	3.5		3.0	4.0	mA
Power Consumption	$V_S = \pm 15\text{V}$, $V_{OUT} = 0$		75	105		90	120	mW

AC Electrical Characteristics for LH0021/LH0021C ($T_A = 25^\circ\text{C}$, $V_S = \pm 15\text{V}$, $C_C = 3000\text{pF}$)

Parameter	Conditions	Limits						Units
		LH0021			LH0021C			
		Min	Typ	Max	Min	Typ	Max	
Slew Rate	$A_V = +1$, $R_L = 100\Omega$	0.8	3.0		1.0	3.0		V/ μs
Power Bandwidth	$R_L = 100\Omega$		20			20		kHz
Small Signal Transient Response			0.3	1.0		0.3	1.5	μs
Small Signal Overshoot			5	20		10	30	%
Settling Time (0.1%)	$\Delta V_{IN} = 10\text{V}$, $A_V = +1$		4			4		μs
Overload Recovery Time			3			3		μs
Harmonic Distortion	$f = 1\text{kHz}$, $P_O = 0.5\text{W}$		0.2			0.2		%
Input Noise Voltage	$R_S = 50\Omega$, B.W. = 10 Hz to 10 kHz		5			5		$\mu\text{V}/\text{rms}$
Input Noise Current	B.W. = 10 Hz to 10 kHz		0.05			0.05		nA/rms

DC Electrical Characteristics for LH0041/LH0041C (Note 4)

Parameter	Conditions	Limits						Units
		LH0041			LH0041C			
		Min	Typ	Max	Min	Typ	Max	
Input Offset Voltage	$R_S < 100\Omega$, $T_A = 25^\circ\text{C}$ $R_S < 100\Omega$		1.0	3.0 5.0		3.0	6.0 7.5	mV mV
Voltage Drift with Temperature	$R_S < 100\Omega$		3			5		$\mu\text{V}/^\circ\text{C}$
Offset Voltage Drift with Time			5			5		$\mu\text{V}/\text{week}$
Offset Voltage Change with Output Power			15			15		$\mu\text{V}/\text{W}$
Offset Voltage Adjustment Range	(Note 5)		20			20		mV
Input Offset Current	$T_A = 25^\circ\text{C}$		30	100 300		50	200 500	nA nA
Offset Current Drift with Temperature			0.1	1.0		0.2	1.0	$\text{nA}/^\circ\text{C}$
Offset Current Drift with Time			2			2		nA/week
Input Bias Current	$T_A = 25^\circ\text{C}$		100	300 1.0		200	500 1.0	nA μA
Input Resistance	$T_A = 25^\circ\text{C}$	0.3	1.0		0.3	1.0		$\text{M}\Omega$
Input Capacitance			3			3		pF
Common Mode Rejection Ratio	$R_S 100\Omega$, $\Delta V_{\text{CM}} = \pm 10\text{V}$	70	90		70	90		dB
Input Voltage Range	$V_S = \pm 15\text{V}$	+12			+12			V
Power Supply Rejection Ratio	$R_S \leq 100\Omega$, $\Delta V_S = \pm 10\text{V}$	80	96		70	90		dB
Voltage Gain	$V_S = \pm 15\text{V}$, $V_O = \pm 10\text{V}$ $R_L = 1\text{ k}\Omega$, $T_A = 25^\circ\text{C}$ $V_S = \pm 15\text{V}$, $V_O = \pm 10\text{V}$ $R_L = 100\Omega$	100	200		100	200		V/mV
		25			20			V/mV
Output Voltage Swing	$V_S = \pm 15\text{V}$, $R_L = 100\Omega$	± 13	14		± 13	± 14		V
Output Short Circuit Current	$V_S = \pm 15\text{V}$, $T_A = 25^\circ\text{C}$ (Note 6)		200	300		200	300	mA
Power Supply Current	$V_S = \pm 15\text{V}$, $V_{\text{OUT}} = 0$		2.5	3.5		3.0	4.0	mA
Power Consumption	$V_S = \pm 15\text{V}$, $V_{\text{OUT}} = 0$		75	105		90	120	mW

AC Electrical Characteristics for LH0041/LH0041C ($T_A = 25^\circ\text{C}$, $V_S = \pm 15\text{V}$, $C_C = 3000\text{ pF}$)

Parameter	Conditions	Limits						Units
		LH0041			LH0041C			
		Min	Typ	Max	Min	Typ	Max	
Slew Rate	$A_V = +1$, $R_L = 100\Omega$	1.5	3.0		1.0	3.0		$\text{V}/\mu\text{s}$
Power Bandwidth	$R_L = 100\Omega$		20			20		kHz
Small Signal Transient Response			0.3	1.0		0.3	1.5	μs
Small Signal Overshoot			5	20		10	30	%
Settling Time (0.1%)	$\Delta V_{\text{IN}} = 10\text{V}$, $A_V = +1$		4			4		μs
Overload Recovery Time			3			3		μs
Harmonic Distortion	$f = 1\text{ kHz}$, $P_O = 0.5\text{W}$		0.2			0.2		%
Input Noise Voltage	$R_S = 50\Omega$, B.W. = 10 Hz to 10 kHz		5			5		$\mu\text{V}/\text{rms}$
Input Noise Current	B.W. = 10 Hz to 10 kHz		0.05			0.05		nA/rms

Note 1: Rating applies for supply voltages above $\pm 15\text{V}$. For supplies less than $\pm 15\text{V}$, rating is equal to supply voltage.

Note 2: Rating applies for LH0041G and LH0021K with $R_{\text{SC}} = 0\Omega$.

Note 3: Rating applies as long as package power rating is not exceeded.

Note 4: Specifications apply for $\pm 5\text{V} \leq V_S \leq \pm 18\text{V}$, and $-55^\circ\text{C} \leq T_C \leq 125^\circ\text{C}$ for LH0021K and LH0041G, and $-25^\circ\text{C} \leq T_C \leq +85^\circ\text{C}$ for LH0021CK, LH0041CG and LH0041CJ unless otherwise specified. Typical values are for 25°C only.

Note 5: TO-8 "G" packages only.

Note 6: Rating applies for "J" DIP package and for TO-8 "G" package with $R_{\text{SC}} = 3.3\text{ ohms}$.

Note 7: See Typical Performance Characteristics.

Typical Performance Characteristics

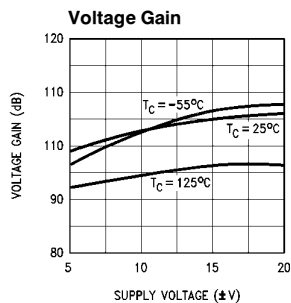
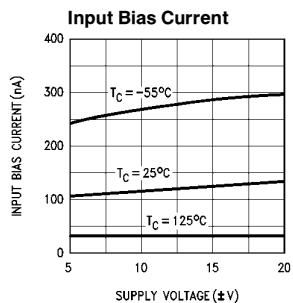
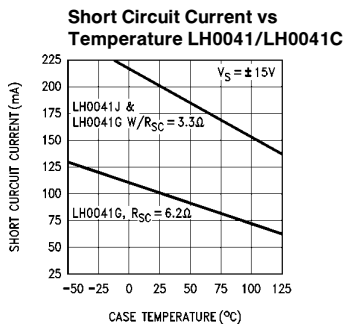
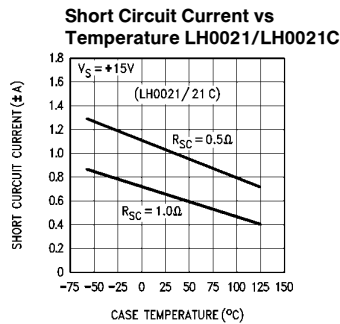
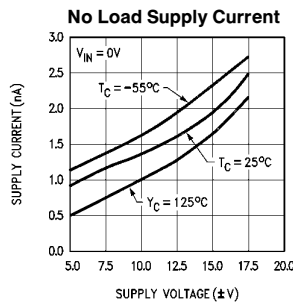
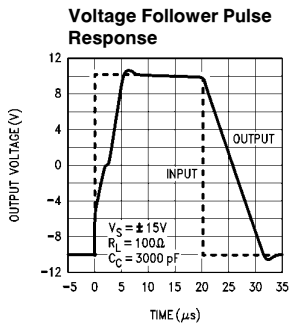
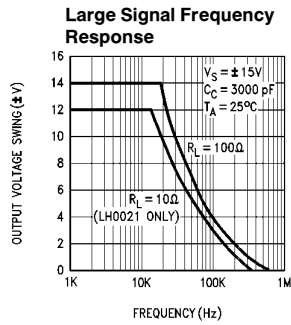
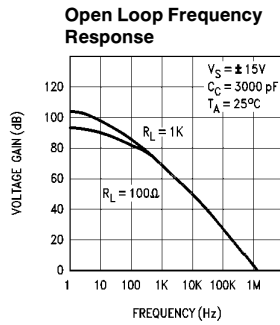
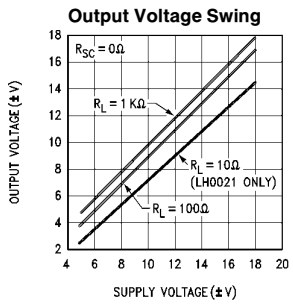
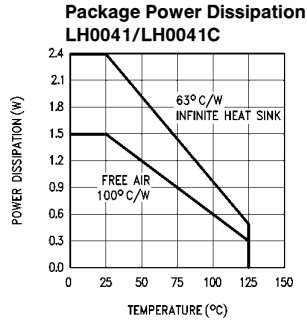
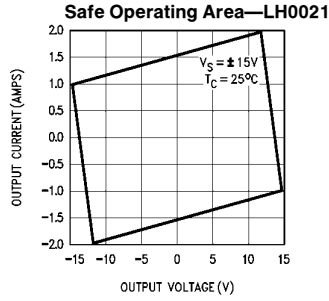
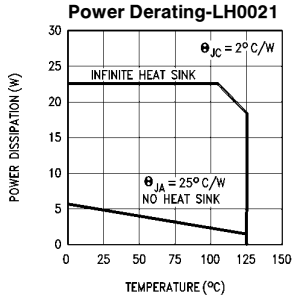

TL/H/9298-6

Typical Performance Characteristics (Continued)

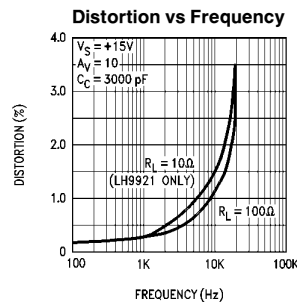
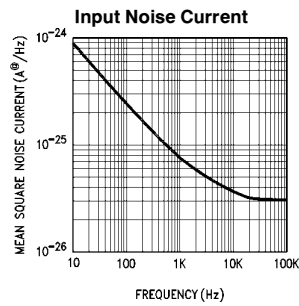
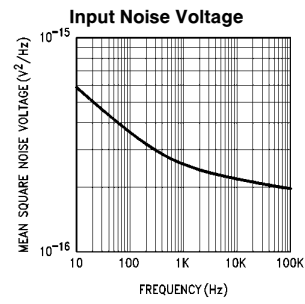
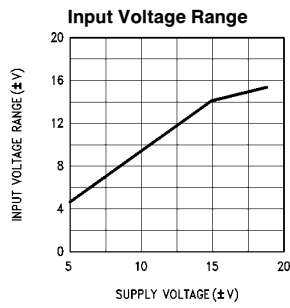
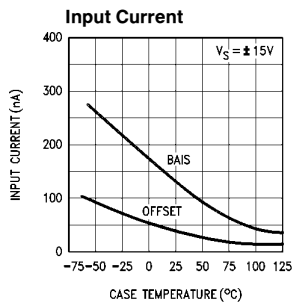

TL/H/9298-7

Connections Diagrams

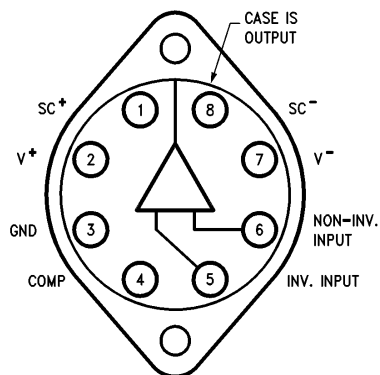

Top View

Order Number LH0021K or LH0021CK
 See NS Package Number K08A

TL/H/9298-2

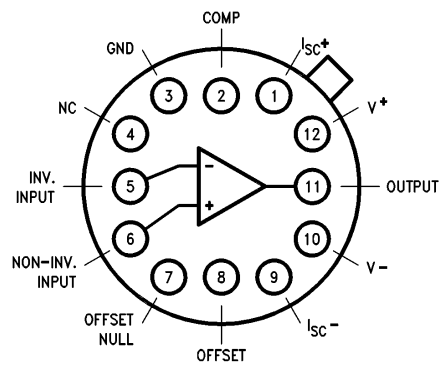

Order Number LH0041G or LH0041CG
 See NS Package Number H12B

TL/H/9298-3

Connection Diagrams (Continued)

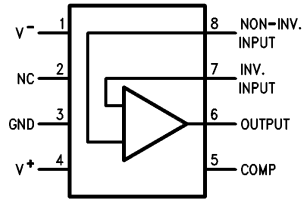

Top View

Order Number LH0041CJ
See NS Package Number HY08A

TL/H/9298-4

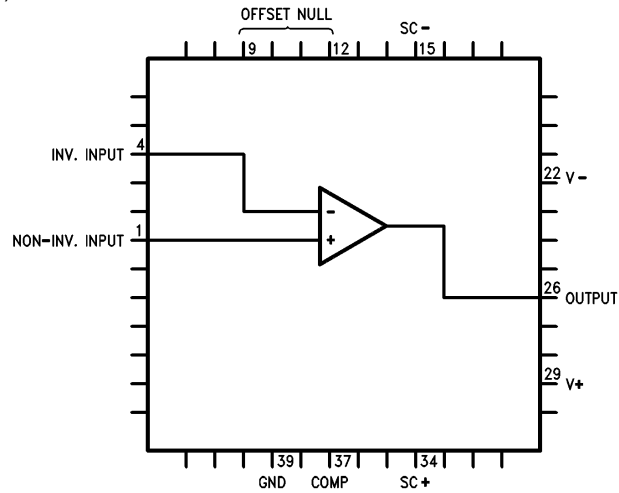

Order Number LH0041E
See NS Package Number E48A

TL/H/9298-5

Typical Applications

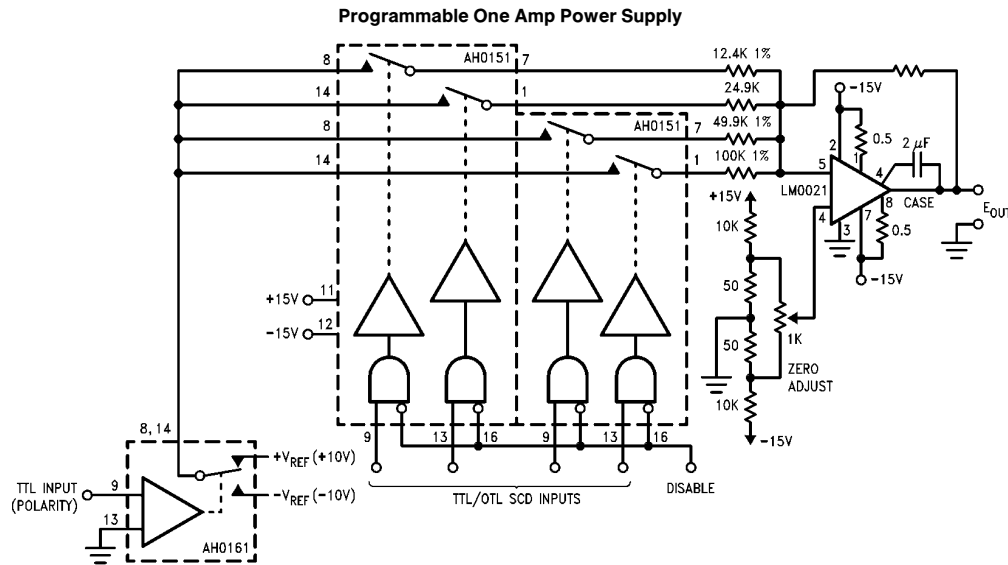

TL/H/9298-8

Typical Applications (Continued)

10W (rms) Audio Amplifier

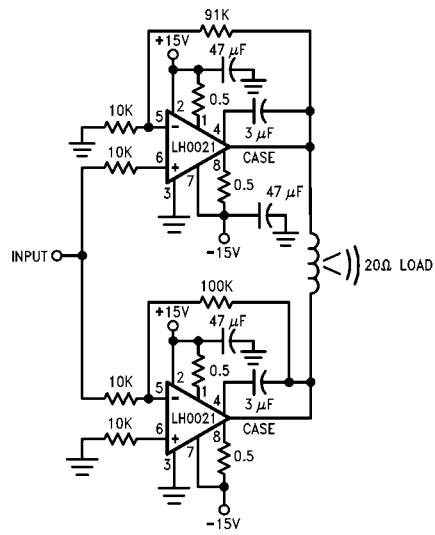

TL/H/9298-9

Dual Tracking One Amp Power Supply

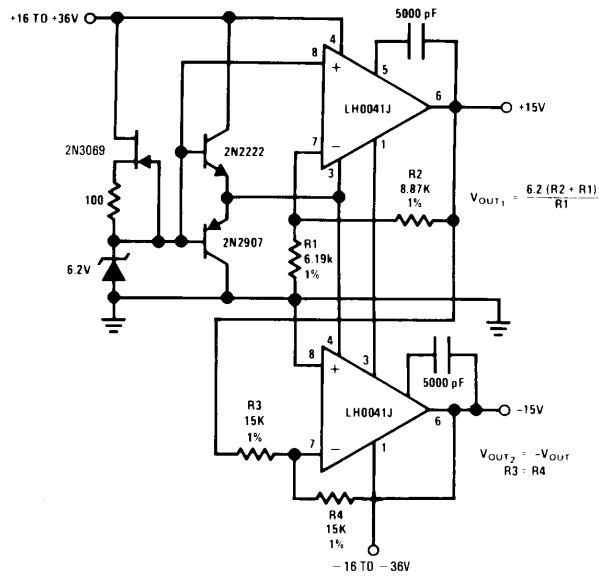

TL/H/9298-10

Typical Applications (Continued)

CRT Deflection Yoke Driver

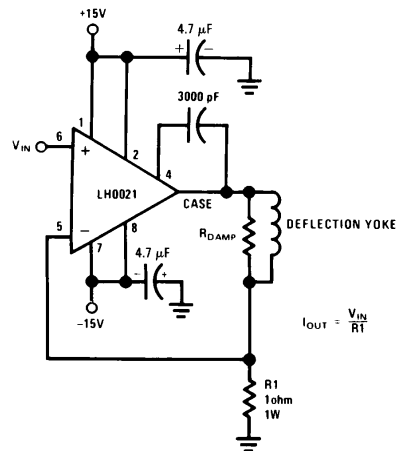

TL/H/9298-11

Two Way Intercom

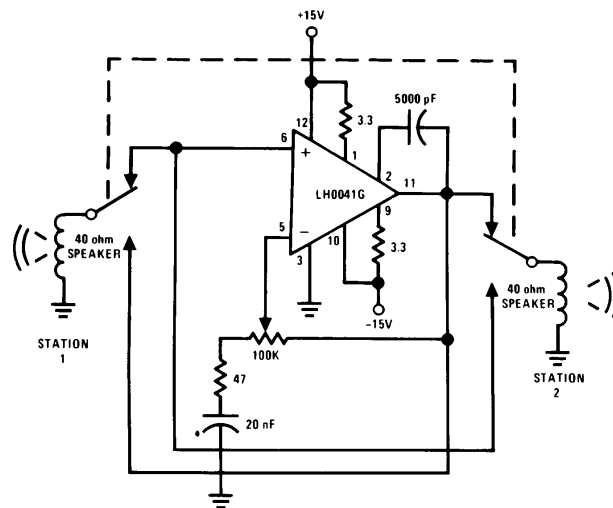

TL/H/9298-12

Programmable High Current Source/Sink

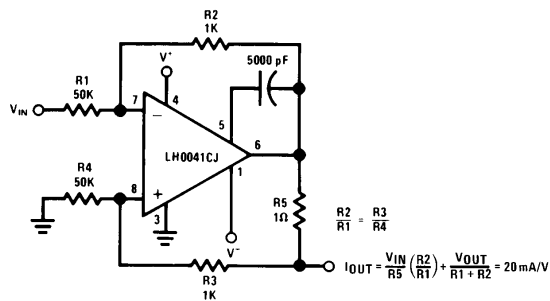

TL/H/9298-13

Typical Applications (Continued)

Power Comparator

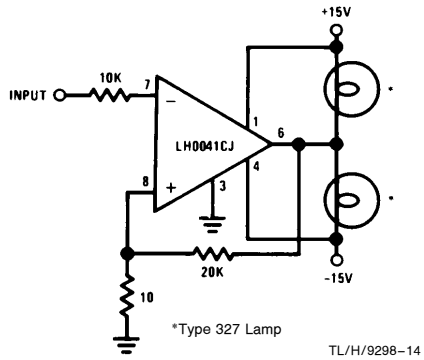

DC Servo Amplifier

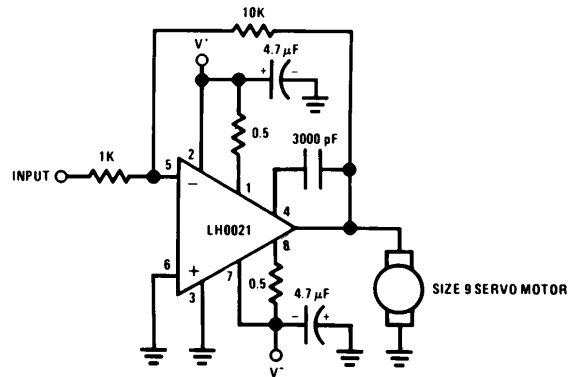

Auxiliary Circuits

LH0021 Unity Gain Circuit with Short Circuit Limiting

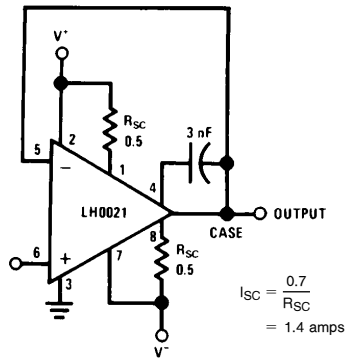

LH0041G Unity Gain with Short Circuit Limiting

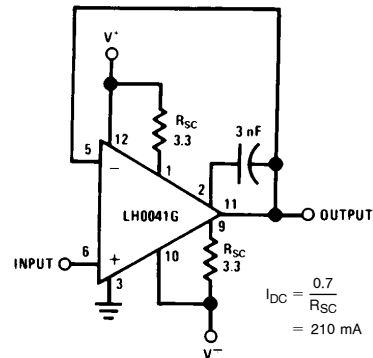

LH0041/LH0021 Offset Voltage Null Circuit* (LH0041CJ Pin Connections Shown)*

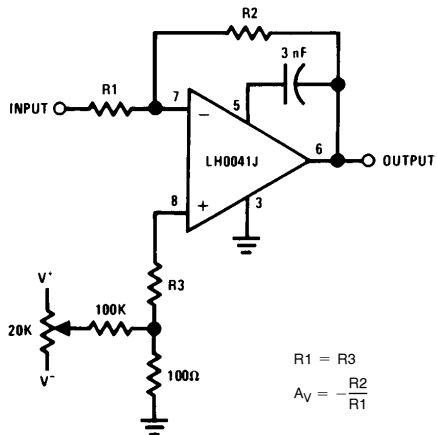

LH0041G Offset Voltage Null Circuit*

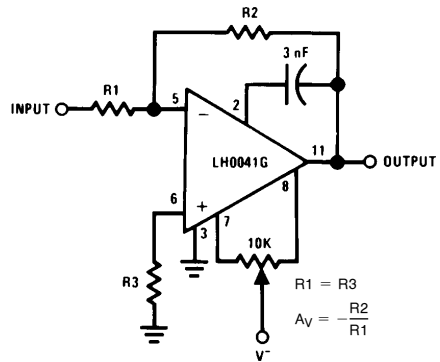

Auxiliary Circuits (Continued)

Operation from Single Supplies

POSITIVE

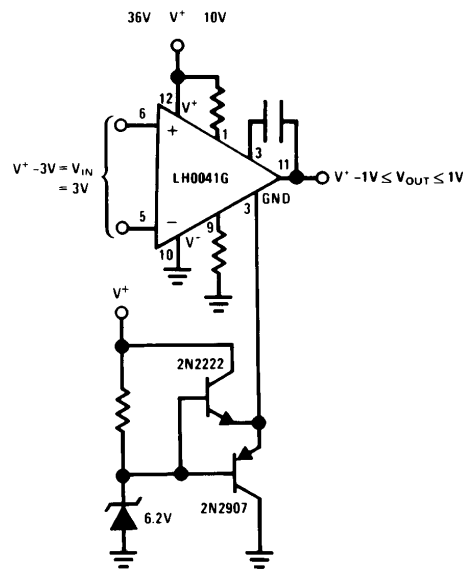

TL/H/9298-20

NEGATIVE

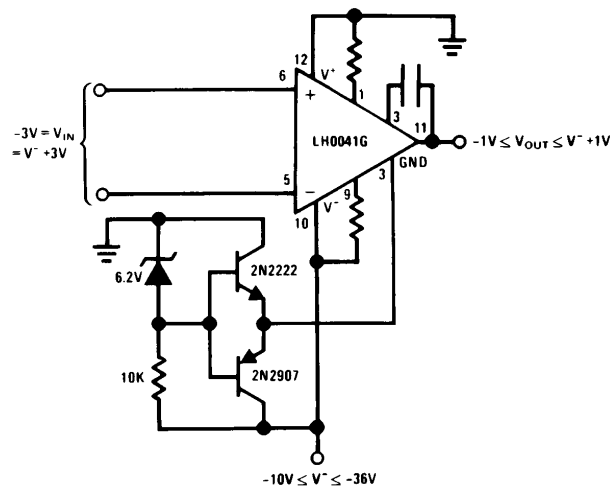

TL/H/9298-21

Auxiliary Circuits (Continued)

Operation from Non-Symmetrical Supplies

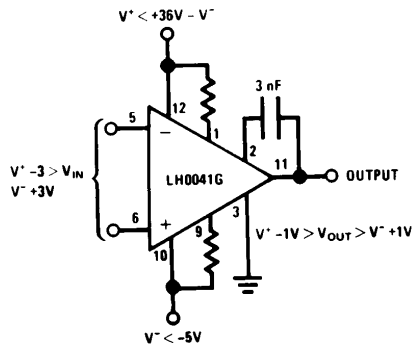

TL/H/9298-22

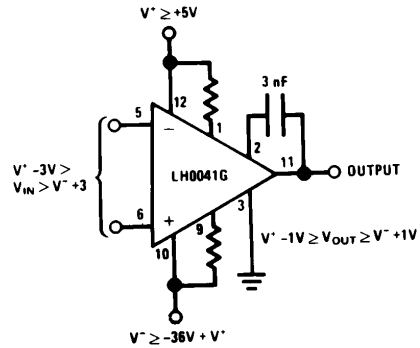

TL/H/9298-23

*For additional offset null circuit techniques see National Linear Applications Handbook.

Physical Dimensions inches (millimeters)

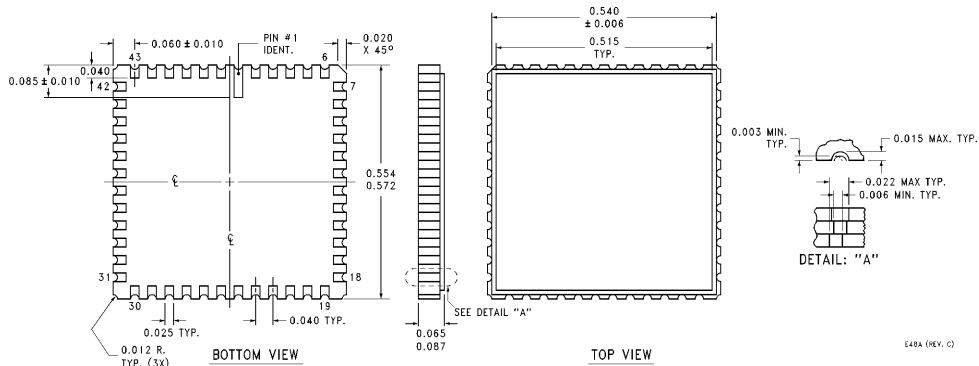

Leadless Chip Carrier (E)
Order Number LH0041E
NS Package Number E48A

E48A (REV. C)

Physical Dimensions inches (millimeters) (Continued)

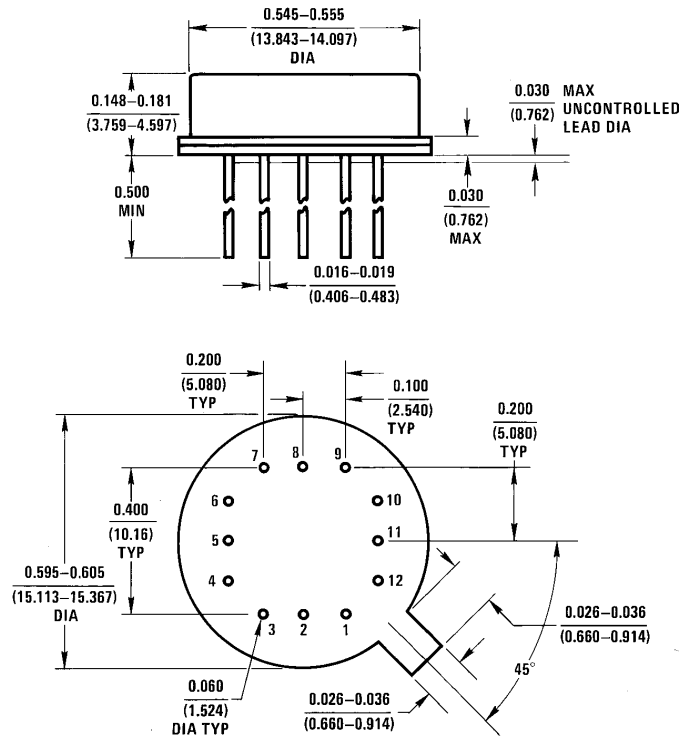

H12B (REV A)

Metal Can Package (H)
Order Number LH0041G or LH0041CG
NS Package Number H12B

Physical Dimensions inches (millimeters) (Continued)

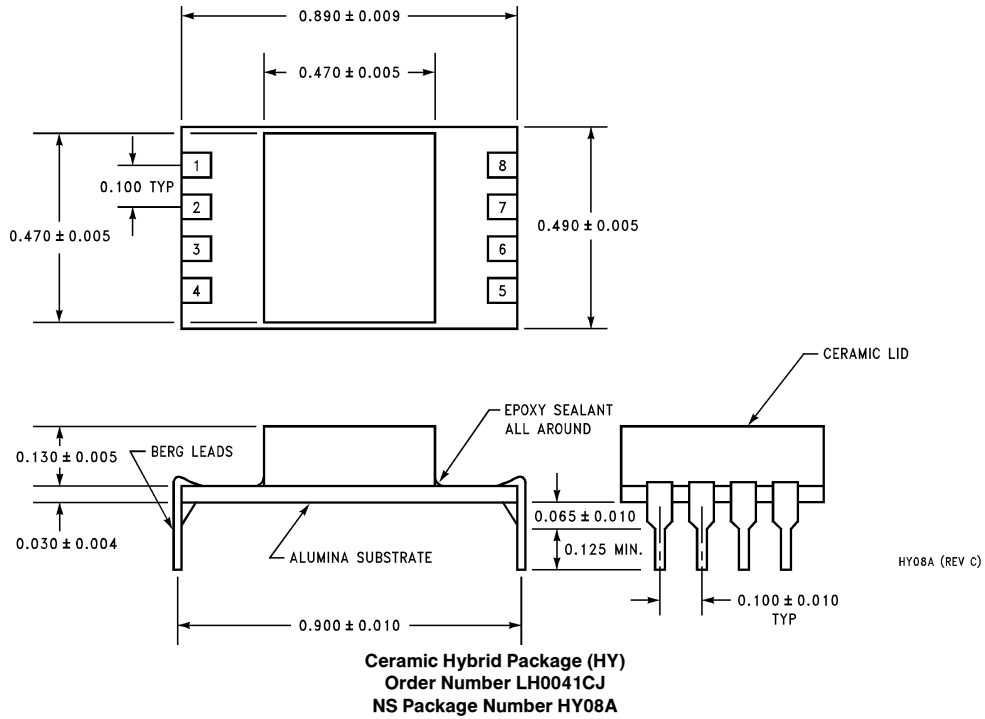

Physical Dimensions inches (millimeters) (Continued)

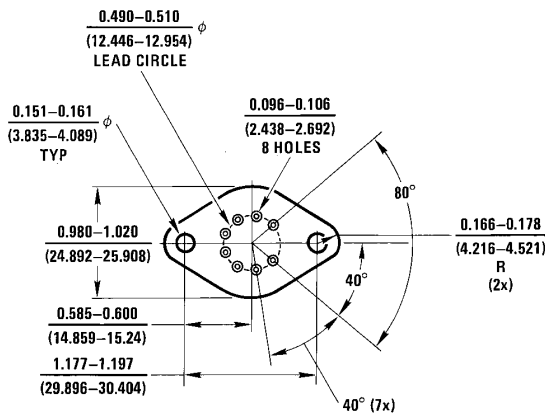
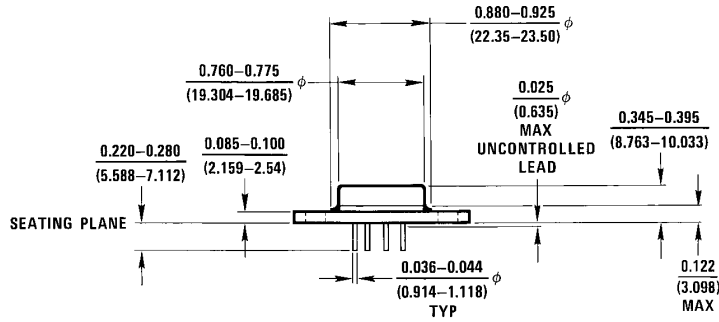

K08A (REV C)

Metal Can Package (K)
Order Number LH0021K or LH0021CK
NS Package Number K08A

LIFE SUPPORT POLICY

NATIONAL'S PRODUCTS ARE NOT AUTHORIZED FOR USE AS CRITICAL COMPONENTS IN LIFE SUPPORT DEVICES OR SYSTEMS WITHOUT THE EXPRESS WRITTEN APPROVAL OF THE PRESIDENT OF NATIONAL SEMICONDUCTOR CORPORATION. As used herein:

1. Life support devices or systems are devices or systems which, (a) are intended for surgical implant into the body, or (b) support or sustain life, and whose failure to perform, when properly used in accordance with instructions for use provided in the labeling, can be reasonably expected to result in a significant injury to the user.
2. A critical component is any component of a life support device or system whose failure to perform can be reasonably expected to cause the failure of the life support device or system, or to affect its safety or effectiveness.



National Semiconductor Corporation
 1111 West Bardin Road
 Arlington, TX 76017
 Tel: 1(800) 272-9959
 Fax: 1(800) 737-7018

National Semiconductor Europe
 Fax: (+49) 0-180-530 85 86
 Email: onjwge@tevm2.nsc.com
 Deutsch Tel: (+49) 0-180-530 85 85
 English Tel: (+49) 0-180-532 78 32
 Français Tel: (+49) 0-180-532 93 58
 Italiano Tel: (+49) 0-180-534 16 80

National Semiconductor Hong Kong Ltd.
 19th Floor, Straight Block,
 Ocean Centre, 5 Canton Rd.
 Tsimshatsui, Kowloon
 Hong Kong
 Tel: (852) 2737-1600
 Fax: (852) 2736-9960

National Semiconductor Japan Ltd.
 Tel: 81-043-299-2309
 Fax: 81-043-299-2408

National does not assume any responsibility for use of any circuitry described, no circuit patent licenses are implied and National reserves the right at any time without notice to change said circuitry and specifications.