

LM110/LM210/LM310 Voltage Follower

General Description

The LM110 series are monolithic operational amplifiers internally connected as unity-gain non-inverting amplifiers. They use super-gain transistors in the input stage to get low bias current without sacrificing speed. Directly interchangeable with 101, 741 and 709 in voltage follower applications, these devices have internal frequency compensation and provision for offset balancing.

The LM110 series are useful in fast sample and hold circuits, active filters, or as general-purpose buffers. Further, the frequency response is sufficiently better than standard IC amplifiers that the followers can be included in the feedback loop without introducing instability. They are plug-in replacements for the LM102 series voltage followers, offer-

ing lower offset voltage, drift, bias current and noise in addition to higher speed and wider operating voltage range.

The LM110 is specified over a temperature range $-55^{\circ}\text{C} \leq T_A \leq +125^{\circ}\text{C}$, the LM210 from $-25^{\circ}\text{C} \leq T_A \leq +85^{\circ}\text{C}$ and the LM310 from $0^{\circ}\text{C} \leq T_A \leq +70^{\circ}\text{C}$.

Features

- Input current 10 nA max over temperature
- Small signal bandwidth 20 MHz
- Slew rate 30 V/ μs
- Supply voltage range $\pm 5\text{V}$ to $\pm 18\text{V}$

Schematic Diagram

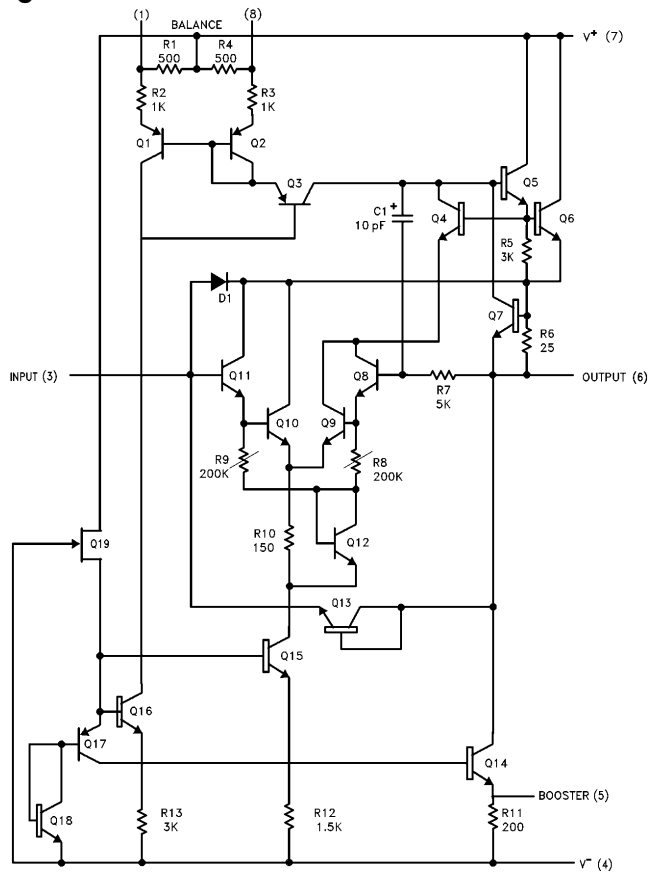

TL/H/7761-1

Absolute Maximum Ratings

If Military/Aerospace specified devices are required, please contact the National Semiconductor Sales Office/Distributors for availability and specifications. (Note 6)

Supply Voltage	± 18V
Power Dissipation (Note 1)	500 mW
Input Voltage (Note 2)	± 15V
Output Short Circuit Duration (Note 3)	Indefinite
Operating Temperature Range	
LM110	−55°C to +125°C
LM210	−25°C to +85°C
LM310	0°C to +70°C

Storage Temperature Range	−65°C to +150°C
Lead Temperature (Soldering, 10 sec.)	260°C
Soldering Information	
Dual-In-Line Package	
Soldering (10 sec.)	260°C
Small Outline Package	
Vapor Phase (60 sec.)	215°C
Infrared (15 sec.)	220°C
See AN-450 "Surface Mounting Methods and Their Effect on Product Reliability" for other methods of soldering surface mount devices.	
ESD rating to be determined.	

Electrical Characteristics (Note 4)

Parameter	Conditions	LM110			LM210			LM310			Units
		Min	Typ	Max	Min	Typ	Max	Min	Typ	Max	
Input Offset Voltage	$T_A = 25^\circ\text{C}$		1.5	4.0		1.5	4.0		2.5	7.5	mV
Input Bias Current	$T_A = 25^\circ\text{C}$		1.0	3.0		1.0	3.0		2.0	7.0	nA
Input Resistance	$T_A = 25^\circ\text{C}$	10^{10}	10^{12}		10^{10}	10^{12}		10^{10}	10^{12}		Ω
Input Capacitance			1.5			1.5			1.5		pF
Large Signal Voltage Gain	$T_A = 25^\circ\text{C}$, $V_S = \pm 15\text{V}$ $V_{OUT} = \pm 10\text{V}$, $R_L = 8\text{ k}\Omega$	0.999	0.9999		0.999	0.9999		0.999	0.9999		V/V
Output Resistance	$T_A = 25^\circ\text{C}$		0.75	2.5		0.75	2.5		0.75	2.5	Ω
Supply Current	$T_A = 25^\circ\text{C}$		3.9	5.5		3.9	5.5		3.9	5.5	mA
Input Offset Voltage				6.0			6.0			10	mV
Offset Voltage Temperature Drift	$-55^\circ\text{C} \leq T_A \leq +85^\circ\text{C}$ $+85 \leq T_A \leq 125^\circ\text{C}$ $0^\circ\text{C} \leq T_A \leq +70^\circ\text{C}$		6 12			6			10		$\mu\text{V}/^\circ\text{C}$ $\mu\text{V}/^\circ\text{C}$ $\mu\text{V}/^\circ\text{C}$
Input Bias Current				10			10			10	nA
Large Signal Voltage Gain	$V_S = \pm 15\text{V}$, $V_{OUT} = \pm 10\text{V}$ $R_L = 10\text{ k}\Omega$	0.999			0.999			0.999			V/V
Output Voltage Swing (Note 5)	$V_S = \pm 15\text{V}$, $R_L = 10\text{ k}\Omega$	± 10			± 10			± 10			V
Supply Current	$T_A = 125^\circ\text{C}$		2.0	4.0		2.0	4.0				mA
Supply Voltage Rejection Ratio	$\pm 5\text{V} \leq V_S \leq \pm 18\text{V}$	70	80		70	80		70	80		dB

Note 1: The maximum junction temperature of the LM110 is 150°C, of the LM210 is 100°C, and of the LM310 is 85°C. For operating at elevated temperatures, devices in the HO8 package must be derated based on a thermal resistance of 165°C/W, junction to ambient, or 22°C/W, junction to case. The thermal resistance of the dual-in-line package is 100°C/W, junction to ambient.

Note 2: For supply voltages less than ± 15V, the absolute maximum input voltage is equal to the supply voltage.

Note 3: Continuous short circuit for the LM110 and LM210 is allowed for case temperatures to 125°C and ambient temperatures to 70°C, and for the LM310, 70°C case temperature or 55°C ambient temperature. It is necessary to insert a resistor greater than 2 k Ω in series with the input when the amplifier is driven from low impedance sources to prevent damage when the output is shorted. $R_S = 5\text{ k}\Omega$ min, 10k typical is recommended for dynamic stability in all applications.

Note 4: These specifications apply for $\pm 5\text{V} \leq V_S \leq \pm 18\text{V}$ and $-55^\circ\text{C} \leq T_A \leq 125^\circ\text{C}$ for the LM110, $-25^\circ\text{C} \leq T_A \leq 85^\circ\text{C}$ for the LM210, and $0^\circ\text{C} \leq T_A \leq 70^\circ\text{C}$ for the LM310 unless otherwise specified.

Note 5: Increased output swing under load can be obtained by connecting an external resistor between the booster and V^- terminals. See curve.

Note 6: Refer to RETS110X for LM110H, LM110J military specifications.

Application Hint

The input must be driven from a source impedance of typically 10 k Ω (5 k Ω min.) to maintain stability. The total source impedance will be reduced at high frequencies if there is stray capacitance at the input pin. In these cases, a 10 k Ω resistor should be inserted in series with the input, physically close to the input pin to minimize the stray capacitance and prevent oscillation.

Typical Performance Characteristics (LM110/LM210)

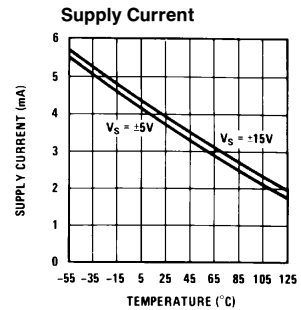
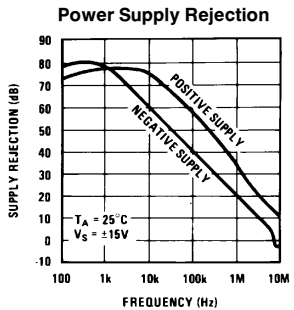
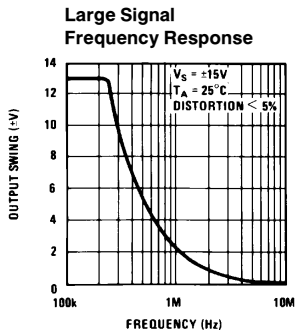
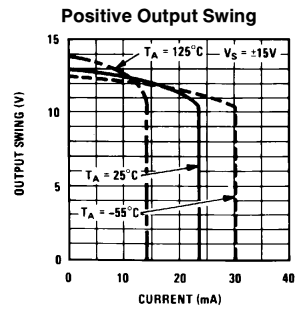
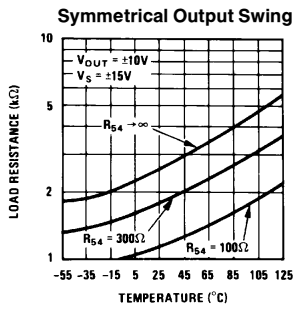
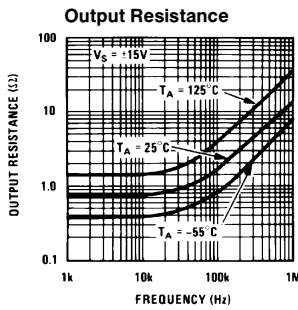
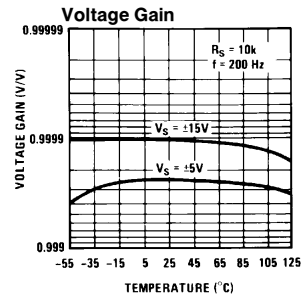
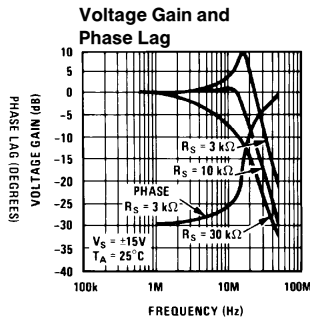
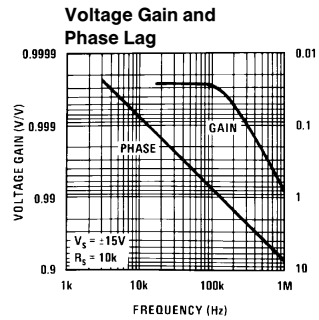
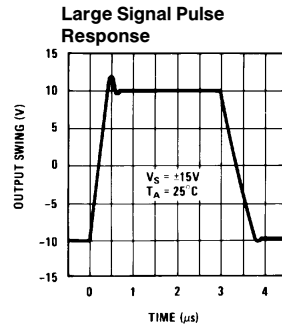
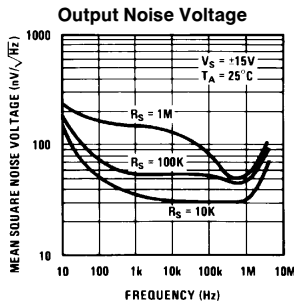
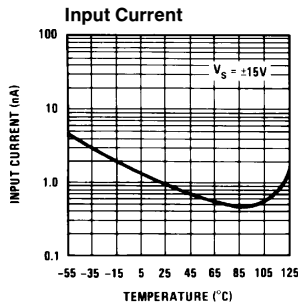

TL/H/7761-28

Typical Performance Characteristics (LM310)

Input Current

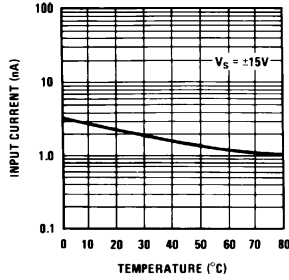

Output Noise Voltage

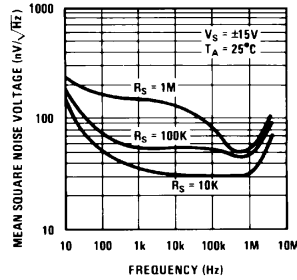

Large Signal Pulse Response

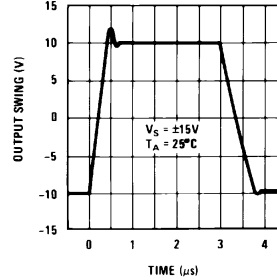

Voltage Gain and Phase Lag

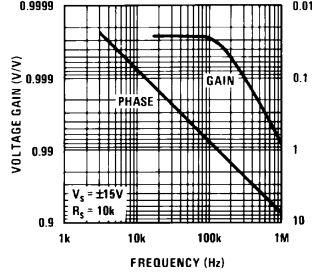

Voltage Gain and Phase Lag

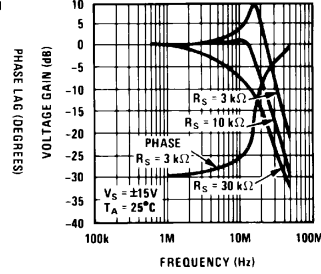

Voltage Gain

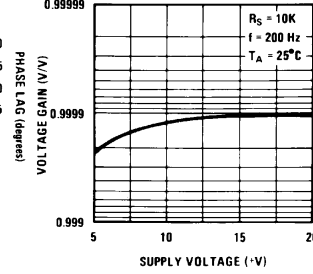

Output Resistance

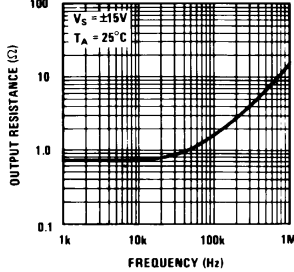

Symmetrical Output Swing

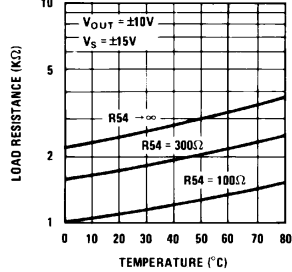

Positive Output Swing

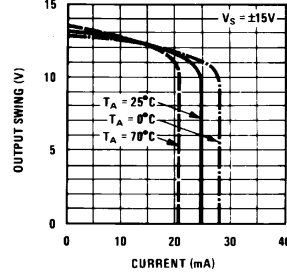

Large Signal Frequency Response

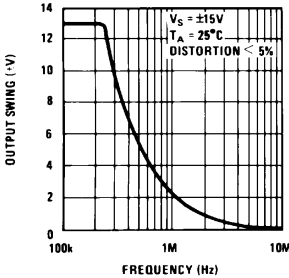

Power Supply Rejection

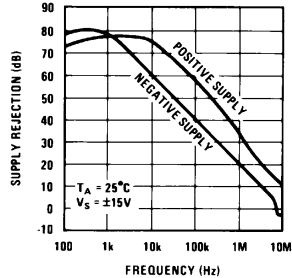

Supply Current

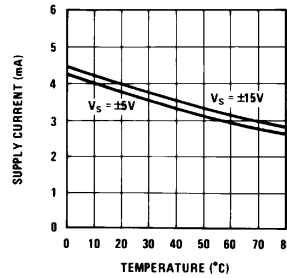

TL/H/7761-29

Auxiliary Circuits

Offset Balancing Circuit

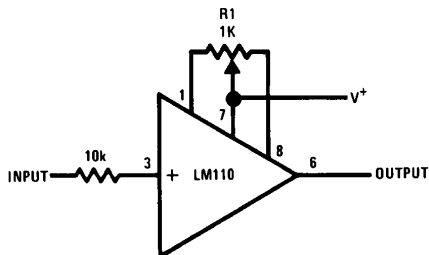

TL/H/7761-2

Increasing Negative Swing Under Load

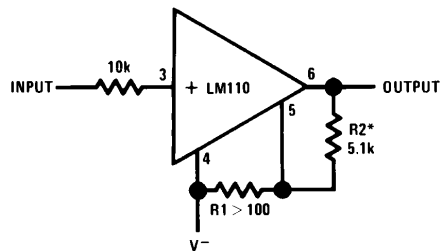

TL/H/7761-3

*May be added to reduce internal dissipation

Typical Applications

Differential Input Instrumentation Amplifier

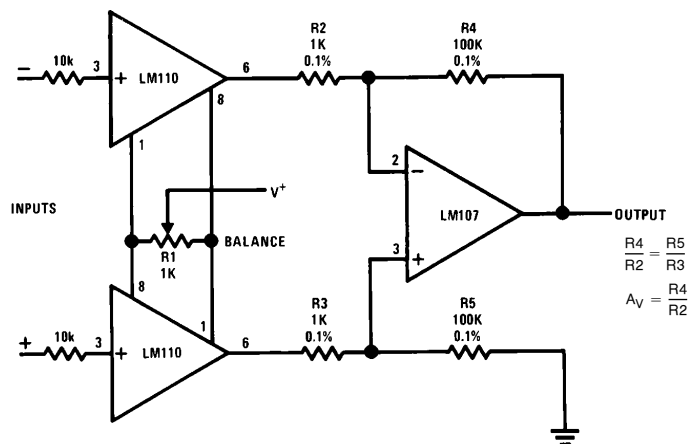

TL/H/7761-4

Fast Integrator with Low Input Current

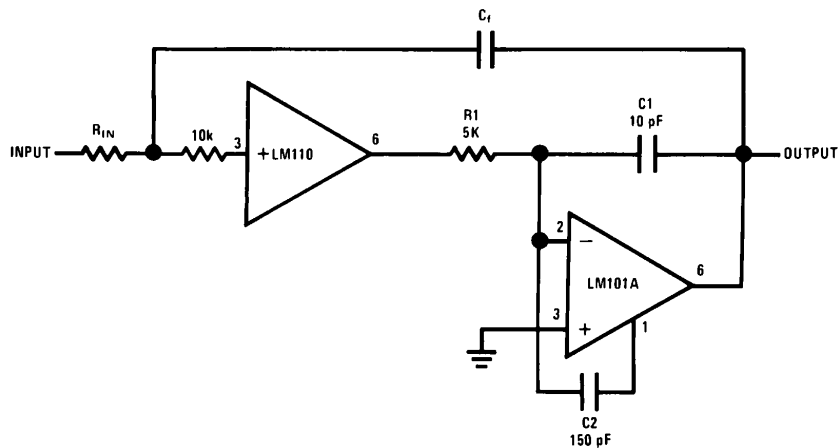

TL/H/7761-5

Typical Applications (Continued)

Fast Inverting Amplifier with High Input Impedance

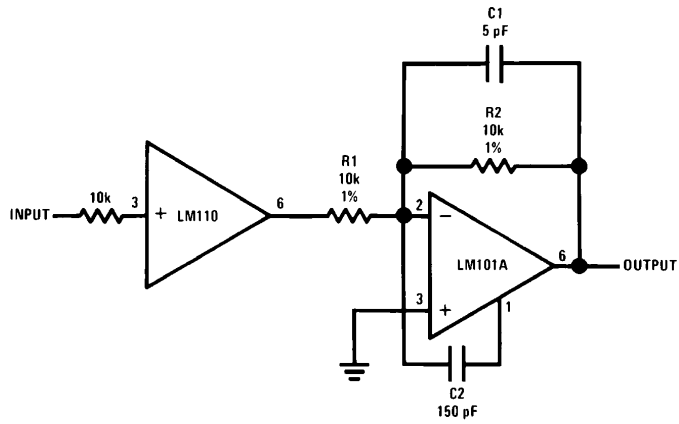

TL/H/7761-6

Comparator for Signals of Opposite Polarity

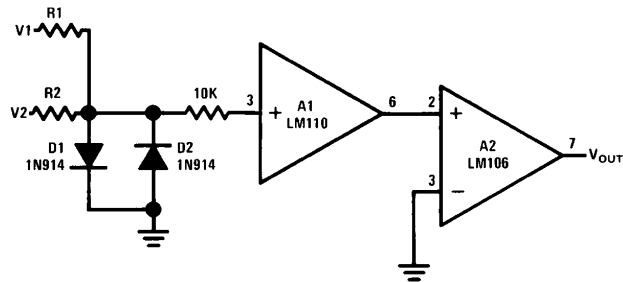

TL/H/7761-7

Zero Crossing Detector

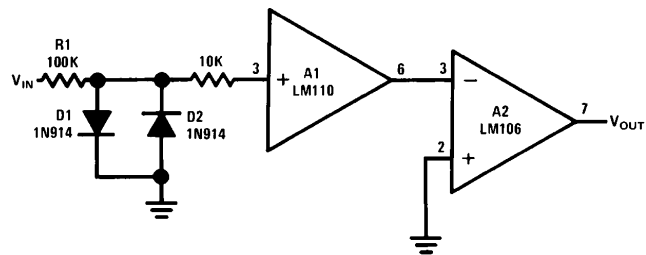

TL/H/7761-9

Typical Applications (Continued)

Driver for A/D Ladder Network

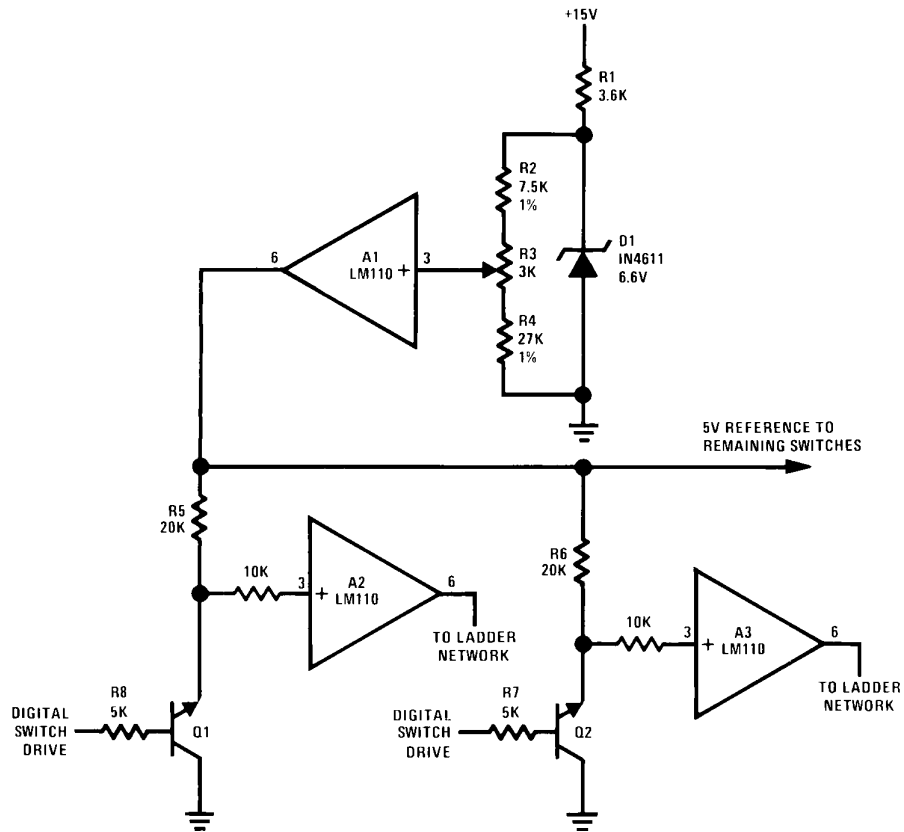

TL/H/7761-8

Buffer for Analog Switch*

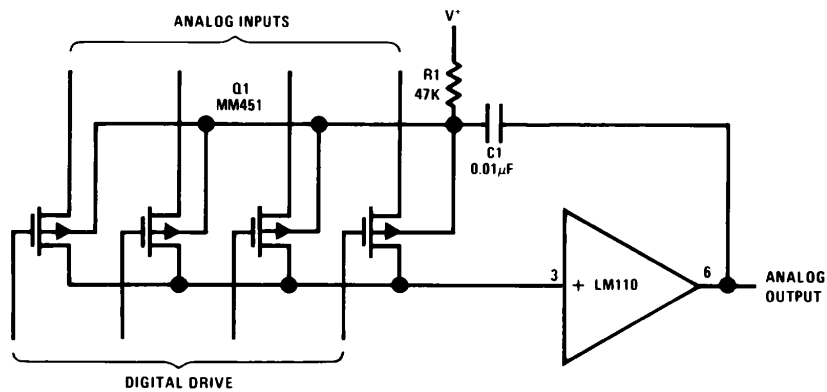

*Switch substrates are boot-strapped to reduce output capacitance of switch.

TL/H/7761-10

Typical Applications (Continued)

Comparator for AC Coupled Signals

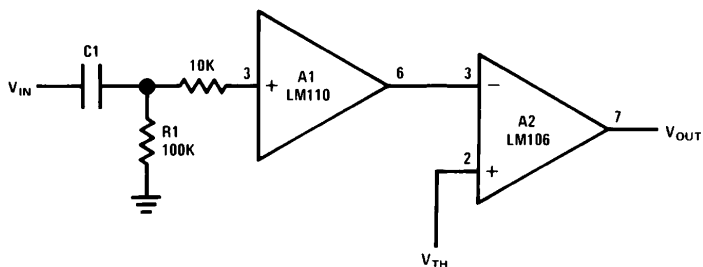

TL/H/7761-11

High Input Impedance AC Amplifier

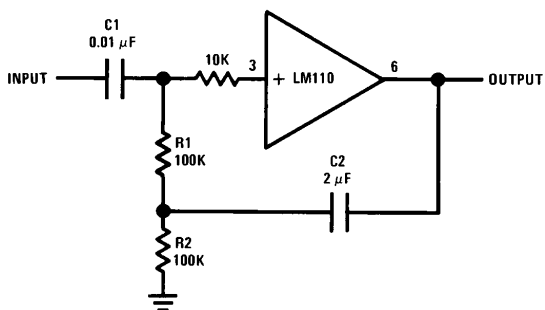

TL/H/7761-12

Comparator for A/D Converter Using a Binary-Weighted Network

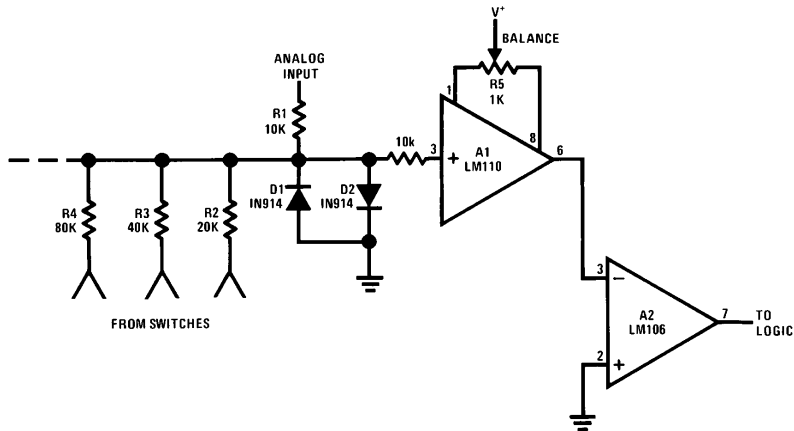

TL/H/7761-13

Typical Applications (Continued)

Bilateral Current Source

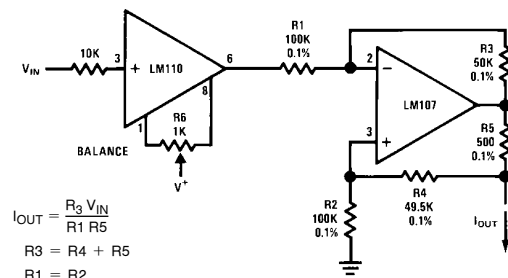

$$I_{OUT} = \frac{R_3 V_{IN}}{R_1 R_5}$$

$$R_3 = R_4 + R_5$$

$$R_1 = R_2$$

TL/H/7761-14

Comparator for A/D Converter Using a Ladder Network

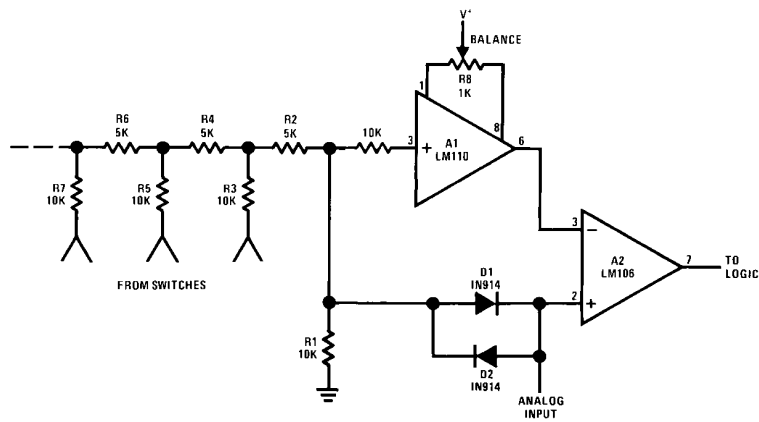

TL/H/7761-15

Sine Wave Oscillator

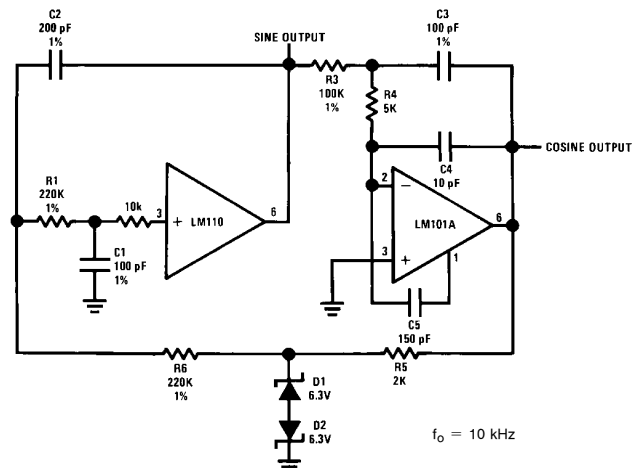

TL/H/7761-16

Typical Applications (Continued)

Low Pass Active Filter

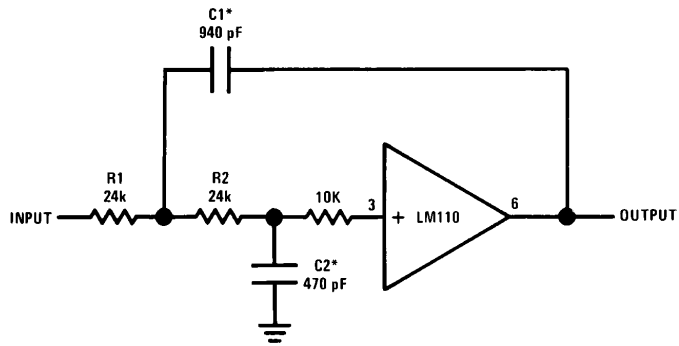

TL/H/7761-18

*Values are for 10 kHz cutoff. Use silvered mica capacitors for good temperature stability.

High Pass Active Filter

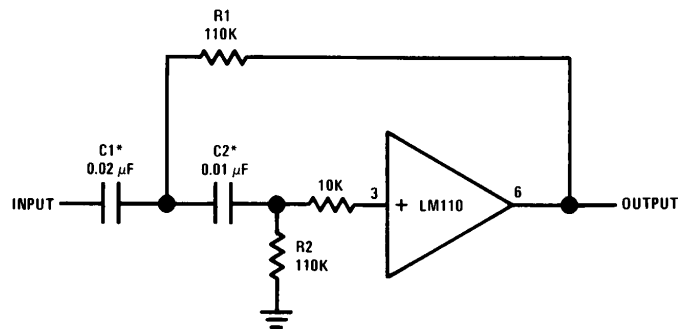

TL/H/7761-19

*Values are for 100 Hz cutoff. Use metallized polycarbonate capacitors for good temperature stability.

Simulated Inductor

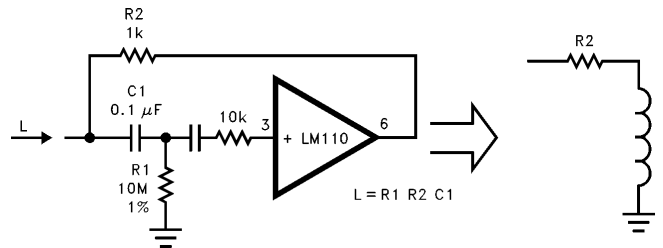

TL/H/7761-21

Typical Applications (Continued)

Adjustable Q Notch Filter

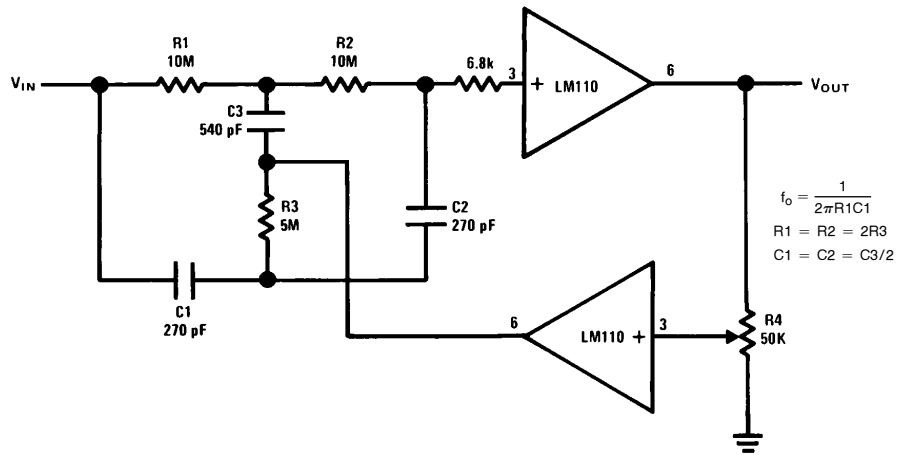

TL/H/7761-22

Bandpass Filter

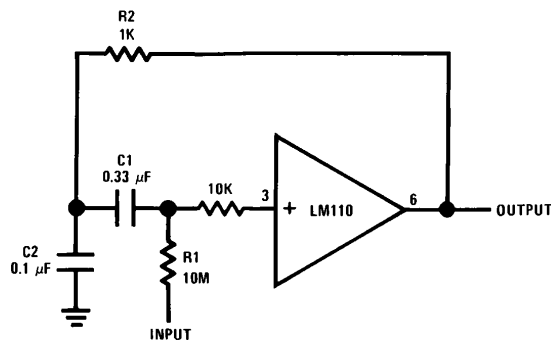

TL/H/7761-23

Sample and Hold

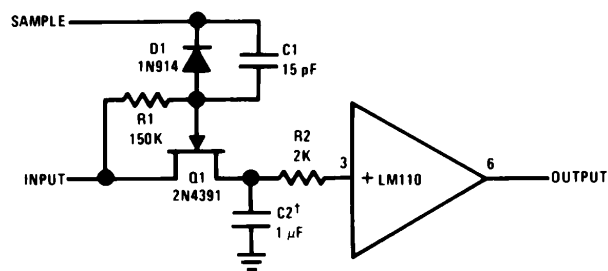

TL/H/7761-24

†Use capacitor with polycarbonate teflon or polyethylene dietic

Typical Applications (Continued)

Buffered Reference Source

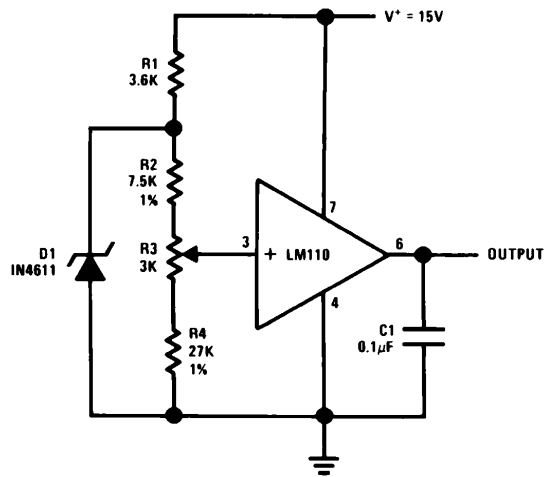

TL/H/7761-25

Low Drift Sample and Hold*

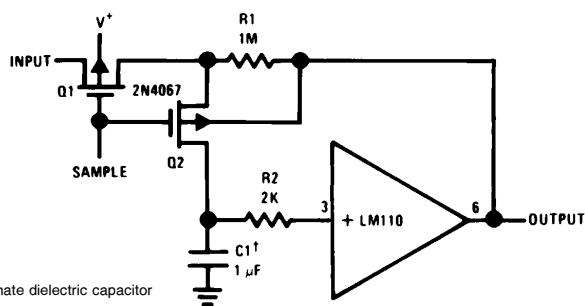

†Teflon polyethylene or polycarbonate dielectric capacitor
*Worst case drift less than 3 mV/sec

TL/H/7761-26

Variable Capacitance Multiplier

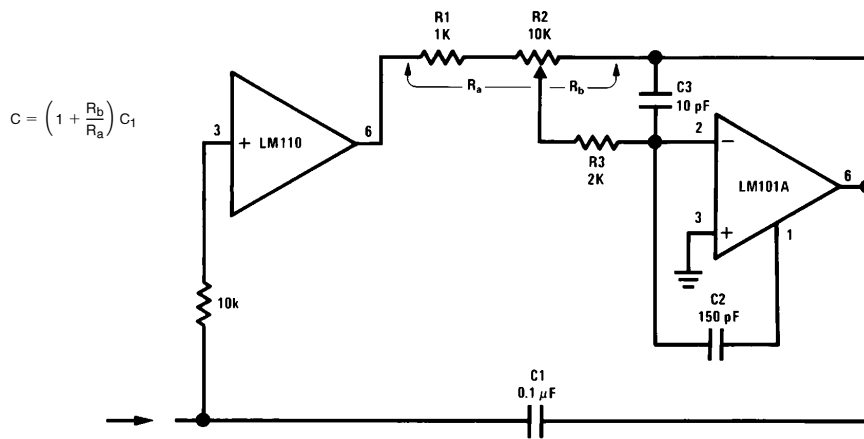

TL/H/7761-27

Connection Diagrams

Metal Can Package

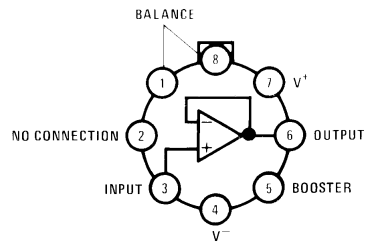

TL/H/7761-30

Package is connected to Pin 4 (V^-)

Top View

Order Number LM110H, LM210H or LM310H
LM110H/883*
See NS Package Number H08C

Dual-In-Line Package

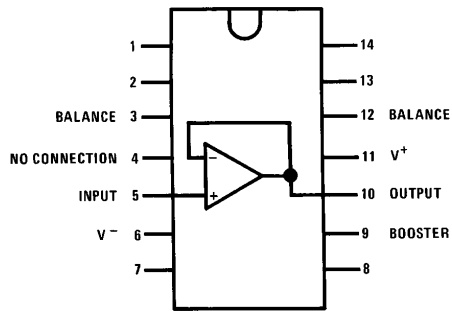

TL/H/7761-31

Top View

Order Number LM110J, LM210J,
LM310J or LM110J/883*
See NS Package Number J14A

Dual-In-Line Package

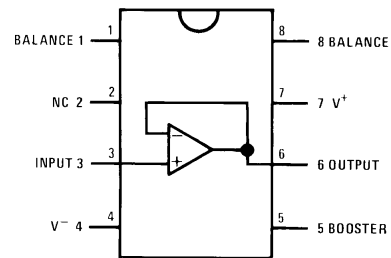

TL/H/7761-32

Top View

Order Number LM310M, LM310N or LM110J-8/883*
See NS Package Number J08A, M08A or N08E

*Available per SMD # 5962-8760601

Physical Dimensions inches (millimeters)

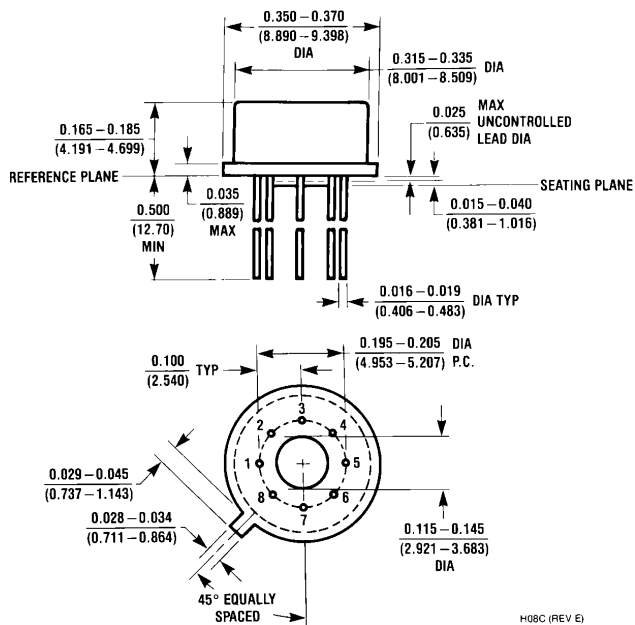

Metal Can Package (H)
 Order Number LM110H, LM110H/883, LM210H or LM310H
 NS Package Number H08C

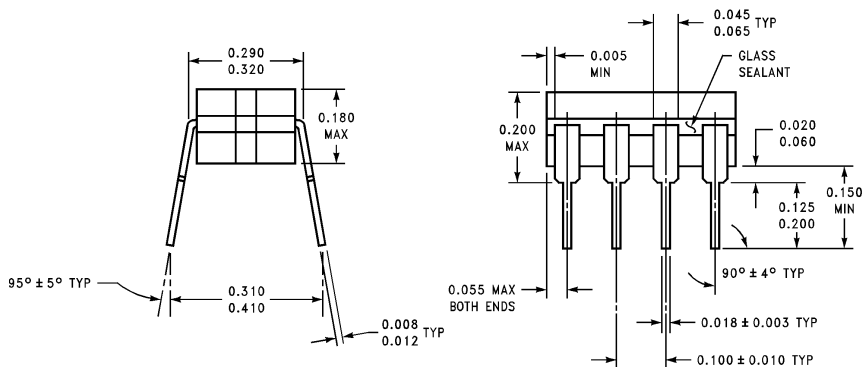
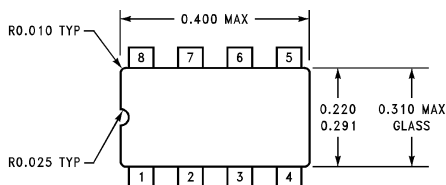

Dual-In-Line Package (J)
 Order Number LM110J-8/883
 NS Package Number J08A

Physical Dimensions inches (millimeters) (Continued)

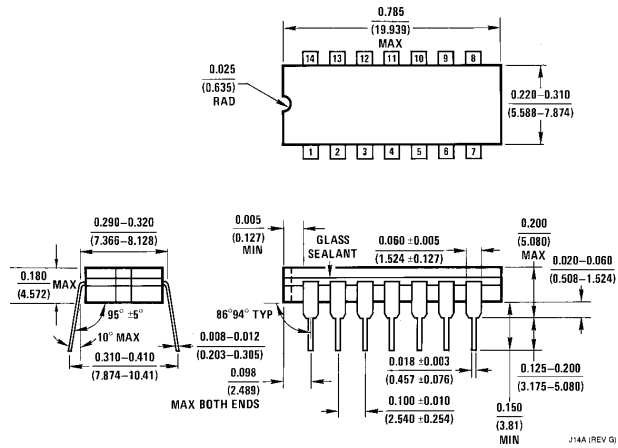

Ceramic Dual-In-Line Package (J)
Order Number LM110J/883
NS Package Number J14A

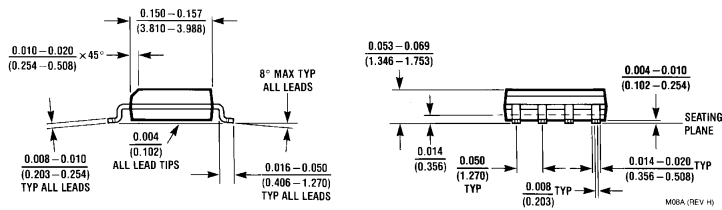
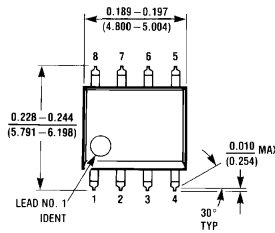

S.O. Package (M)
Order Number LM310M
NS Package Number M08A

Physical Dimensions inches (millimeters) (Continued)

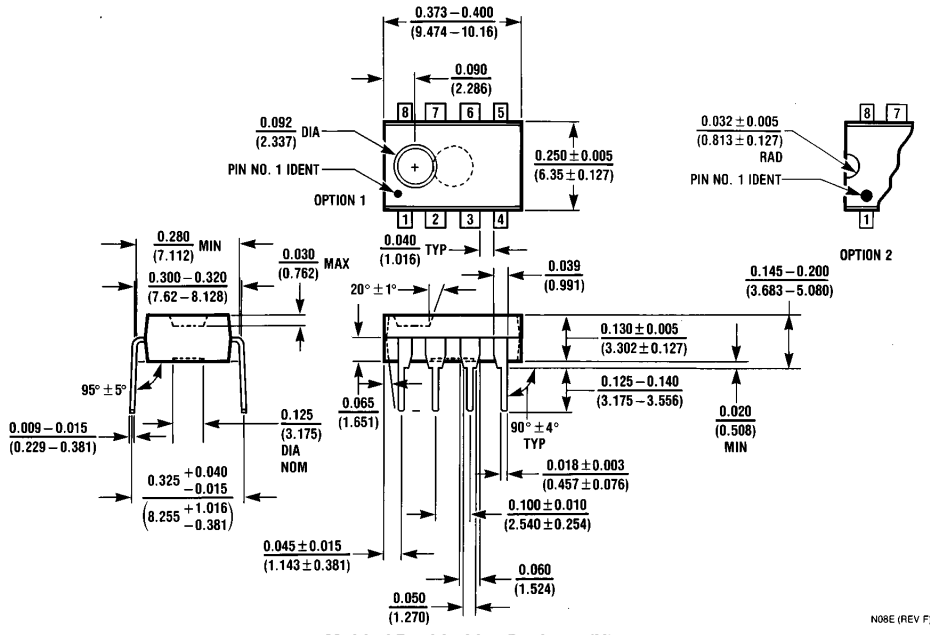

Molded Dual-In-Line Package (N)
Order Number LM310N
NS Package Number N08E

N08E (REV F)

LIFE SUPPORT POLICY

NATIONAL'S PRODUCTS ARE NOT AUTHORIZED FOR USE AS CRITICAL COMPONENTS IN LIFE SUPPORT DEVICES OR SYSTEMS WITHOUT THE EXPRESS WRITTEN APPROVAL OF THE PRESIDENT OF NATIONAL SEMICONDUCTOR CORPORATION. As used herein:

1. Life support devices or systems are devices or systems which, (a) are intended for surgical implant into the body, or (b) support or sustain life, and whose failure to perform, when properly used in accordance with instructions for use provided in the labeling, can be reasonably expected to result in a significant injury to the user.
2. A critical component is any component of a life support device or system whose failure to perform can be reasonably expected to cause the failure of the life support device or system, or to affect its safety or effectiveness.



National Semiconductor Corporation
 1111 West Bardin Road
 Arlington, TX 76017
 Tel: (800) 272-9959
 Fax: (800) 737-7018

National Semiconductor Europe
 Fax: (+49) 0-180-530 85 86
 Email: cnjwge@tevm2.nsc.com
 Deutsch Tel: (+49) 0-180-530 85 85
 English Tel: (+49) 0-180-532 78 32
 Français Tel: (+49) 0-180-532 93 58
 Italiano Tel: (+49) 0-180-534 16 80

National Semiconductor Hong Kong Ltd.
 19th Floor, Straight Block,
 Ocean Centre, 5 Canton Rd.
 Tsimshatsui, Kowloon
 Hong Kong
 Tel: (852) 2737-1600
 Fax: (852) 2736-9960

National Semiconductor Japan Ltd.
 Tel: 81-043-299-2309
 Fax: 81-043-299-2408

National does not assume any responsibility for use of any circuitry described, no circuit patent licenses are implied and National reserves the right at any time without notice to change said circuitry and specifications.