

Ultra Low Noise Wideband Op Amp

General Description

The CLC425 combines a wide bandwidth (**1.9GBW**) with a very low input noise ($1.05\text{nV}/\sqrt{\text{Hz}}$, $1.6\text{pA}/\sqrt{\text{Hz}}$) and low dc errors ($100\mu\text{V } V_{\text{OS}}$, $2\mu\text{V}/^\circ\text{C}$ drift) to provide a very precise, wide dynamic range op amp offering closed-loop gains of ≥ 10 .

Singularly suited for very wideband high gain operation, the CLC425 employs a traditional voltage feedback topology providing all the benefits of balanced inputs, such as low offsets and drifts, as well as a 96dB open loop gain, a 100dB CMRR and a 95dB PSRR.

The CLC425 also offers great flexibility with its externally adjustable supply current, allowing designers to easily choose the optimum set of power, bandwidth, noise and distortion performance. Operating from $\pm 5\text{V}$ power supplies, the CLC425 defaults to a 15mA quiescent current, or by adding one external resistor, the supply current can be adjusted to less than 5mA.

The CLC425's combination of ultra low noise, wide gain bandwidth, high slew rate and low dc errors will enable applications in areas such as medical diagnostic ultrasound, magnetic tape & disk storage, communications and opto-electronics to achieve maximum high frequency signal-to-noise ratios.

Enhanced Solutions (Military/Aerospace)

SMD Number: 5962-93259

Space level versions also available.

For more information, visit <http://www.national.com/mil>

Features

- 1.9GHz gain-bandwidth product
- $1.05\text{nV}/\sqrt{\text{Hz}}$ input voltage noise
- $0.8\text{pA}/\sqrt{\text{Hz}}$ @ $I_{\text{CC}} \leq 5\text{mA}$
- $100\mu\text{V}$ input offset voltage, $2\mu\text{V}/^\circ\text{C}$ drift

- $350\text{V}/\mu\text{s}$ slew rate
- 15mA to 5mA adjustable supply current
- Gain range ± 10 to $\pm 1,000\text{V}/\text{V}$
- Evaluation boards & simulation macromodel
- 0.9dB NF @ $R_s = 700\Omega$

Applications

- Instrumentation sense amplifiers
- Ultrasound pre-amps
- Magnetic tape & disk pre-amps
- Photo diode transimpedance amplifiers
- Wide band active filters
- Low noise figure RF amplifiers
- Professional audio systems
- Low noise loop filters for PLLs

Equivalent Input Voltage Noise

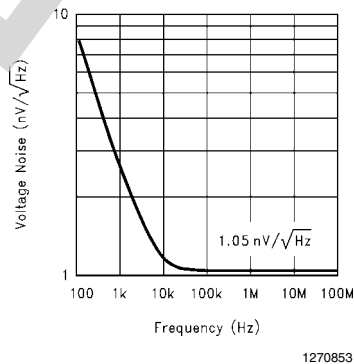

Connection Diagrams

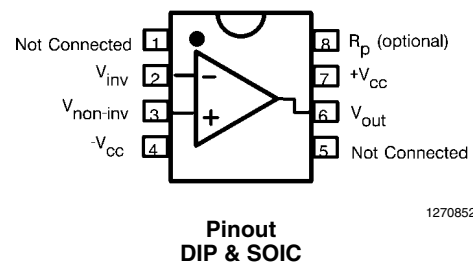
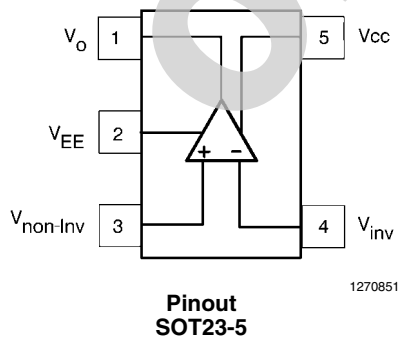

Ordering Information

Package	Temperature Range Industrial	Part Number	Package Marking	NSC Drawing
8-pin plastic DIP	-40°C to +85°C	CLC425AJP	CLC425AJP	N08E
8-pin plastic SOIC	-40°C to +85°C	CLC425AJE	CLC425AJE	M08A
5-pin SOT	-40°C to +85°C	CLC425AJM5	A19	MA05A

OBSOLETE

Absolute Maximum Ratings (Note 1)

If Military/Aerospace specified devices are required, please contact the National Semiconductor Sales Office/Distributors for availability and specifications.

Supply Voltage (V_{CC})	$\pm 7V$
I_{OUT}	125mA
Output is short circuit protected to ground, but maximum reliability will be maintained if I_{OUT} does not exceed...	
Common Mode Input Voltage	$\pm V_{CC}$
Maximum Junction Temperature	+150°C

Operating Temperature Range	-40°C to +85°C
Storage Temperature Range	-65°C to +150°C
Lead Solder Duration (+300°C)	10 sec
ESD rating (human body model)	1000V

Operation Ratings

Thermal Resistance		
Package	(θ_{JC})	(θ_{JA})
MDIP	70°C/W	125°C/W
SOIC	65°C/W	145°C/W
SOT-23	115°C/W	185°C/W

Electrical Characteristics

$A_V = +20$, $V_{CC} = \pm 5V$, $R_g = 26.1\Omega$, $R_L = 100\Omega$, $R_f = 499\Omega$; unless specified

Symbol	Parameter	Conditions	Typ	Min/Max (Note 2)			Units
Ambient Temperature		CLC425AJ	+25°C	-40°C	+25°C	+85°	
Frequency Domain Response							
GBW	Gain Bandwidth Product	$V_{OUT} < 0.4V_{PP}$	1.9	1.5	1.5	1.0	GHz
SSBW	-3dB Bandwidth	$V_{OUT} < 0.4V_{PP}$	95	75	75	50	MHz
LSBW		$V_{OUT} < 5.0V_{PP}$	40	30	30	20	MHz
	Gain Flatness	$V_{OUT} < 0.4V_{PP}$					
GFP	Peaking	DC to 30MHz	0.3	0.7	0.5	0.7	dB
GFR	Rolloff	DC to 30MHz	0.1	0.7	0.5	0.7	dB
LPD	Linear Phase Deviation	DC to 30MHz	0.7	1.5	1.5	2.5	deg
Time Domain Response							
TRS	Rise and Fall Time	0.4V Step	3.7	4.7	4.7	7.0	ns
TSS	Settling Time to 0.2%	2V Step	22	30	30	40	ns
OS	Overshoot	0.4V Step	5	12	10	12	%
SR	SlewRate	2V Step	350	250	250	200	V/ μ s
Distortion And Noise Response							
HD2	2nd Harmonic Distortion	1V _{PP} , 10MHz	-53	48	48	46	dBc
HD3	3rd Harmonic Distortion	1V _{PP} , 10MHz	-75	65	65	60	dBc
IMD	3rd Order Intermodulation Intercept	10MHz	35				dBm
	Equivalent Input Noise						
VN	Voltage	1MHz to 100MHz	1.05	1.25	1.25	1.8	nV/ \sqrt{Hz}
ICN	Current	1MHz to 100MHz	1.6	4.0	2.5	2.5	pA/ \sqrt{Hz}
NF	Noise Figure	$R_s = 700\Omega$	0.9				dB
Static, DC Performance							
AOL	Open Loop Gain	DC	96	77	86	86	dB
VIO	Input Offset Voltage (Note 3)		± 100	± 1000	± 800	± 1000	μ V
DVIO	Average Drift		± 2	8	-	4	μ V/°C
IB	Input Bias Current (Note 3)	Non-Inverting	12	40	20	20	μ A
DIB	Average Drift		-100	-250	-	-120	nA/°C
IIO	Input Offset Current		± 0.2	3.4	2.0	2.0	μ A
DIIO	Average Drift		± 3	± 50	-	± 25	nA/°C
PSRR	Power Supply Rejection Ratio	DC	95	82	88	86	dB
CMRR	Common Mode Rejection Ratio	DC	100	88	92	90	dB
ICC	Supply Current (Note 3)	$R_L = \infty$	15	18	16	16	mA
Miscellaneous Performance							
RINC	Input Resistance	Common-Mode	2	0.6	1.6	1.6	M Ω

Symbol	Parameter	Conditions	Typ	Min/Max (Note 2)			Units
RIND		Differential-Mode	6	1	3	3	k Ω
CINC	Input Capacitance	Common-Mode	1.5	2	2	2	pF
CIND		Differential-Mode	1.9	3	3	3	pF
ROUT	Output Resistance	Closed Loop	5	50	10	10	m Ω
VO	Output Voltage Range	$R_L = \infty$	± 3.8	± 3.5	± 3.7	± 3.7	V
VOL		$R_L = 100\Omega$	± 3.4	± 2.8	± 3.2	± 3.2	V
CMIR	Input Voltage Range	Common Mode	± 3.8	± 3.4	± 3.5	± 3.5	V
IOP	Output Current	Source	80	70	70	70	mA
ION		Sink	90	45	55	55	mA

Note 1: "Absolute Maximum Ratings" are those values beyond which the safety of the device cannot be guaranteed. They are not meant to imply that the devices should be operated at these limits. The table of "Electrical Characteristics" specifies conditions of device operation.

Note 2: Max/min ratings are based on product characterization and simulation. Individual parameters are tested as noted. Outgoing quality levels are determined from tested parameters.

Note 3: AJ-level: spec. is 100% tested at +25°C, sample at 85°C.

Typical Performance Characteristics

Non-Inverting Frequency Response

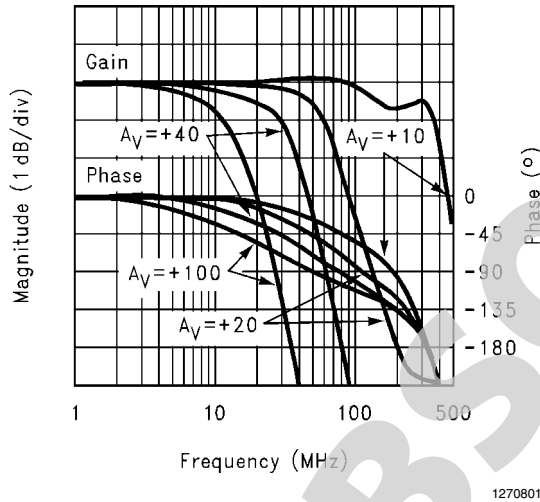

1270801

Inverting Frequency Response

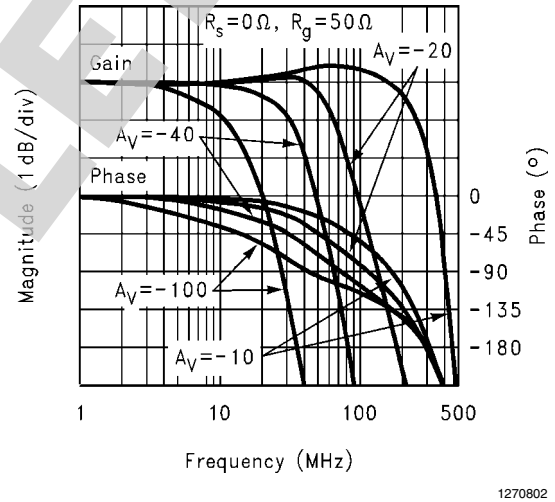

1270802

Frequency Response vs. I_{CC} ($A_V = +20$)

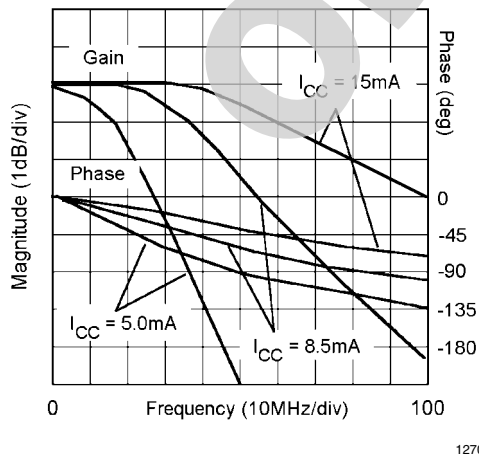

1270803

Open Loop Gain and Phase vs. I_{CC}

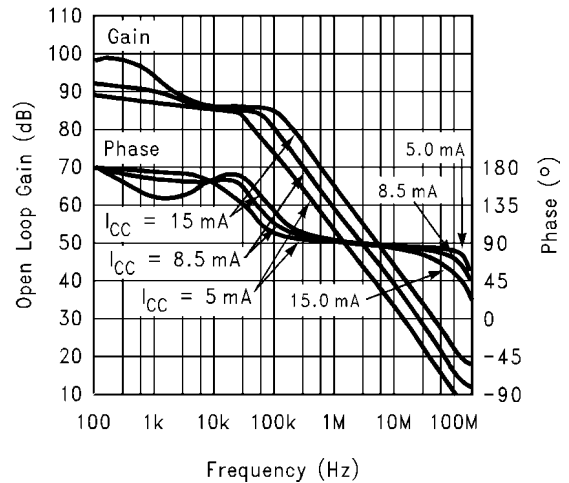

1270804

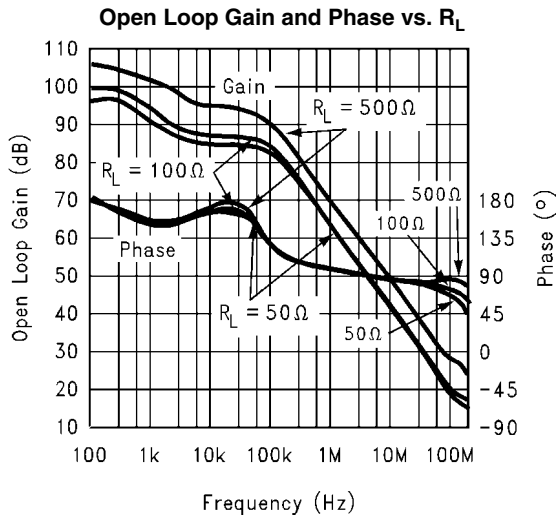

1270805

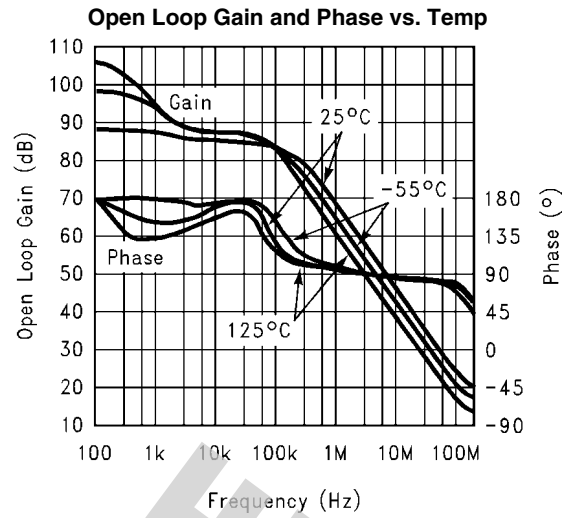

1270806

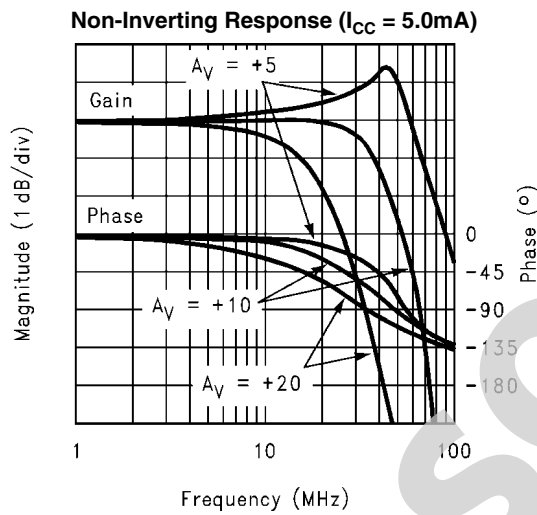

1270807

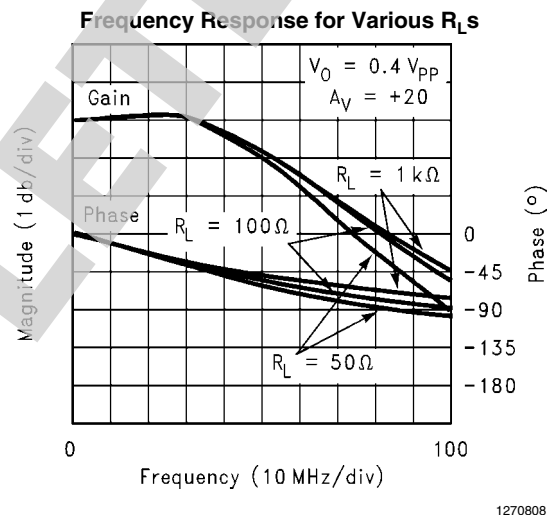

1270808

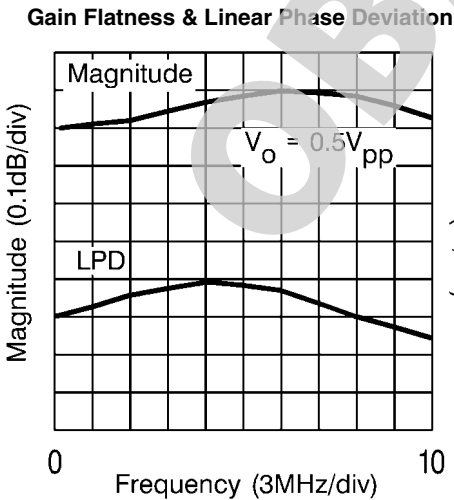

1270809

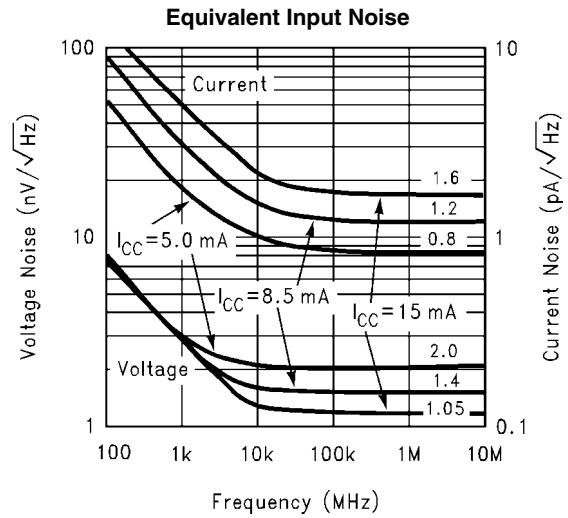

1270810

Maximum Output Swing vs. Frequency

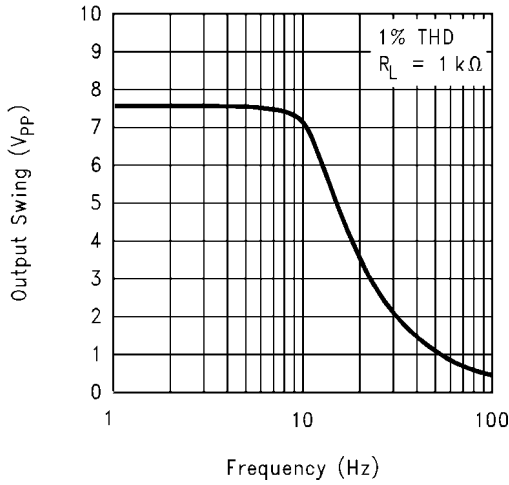

1270811

Closed-Loop Output Impedance

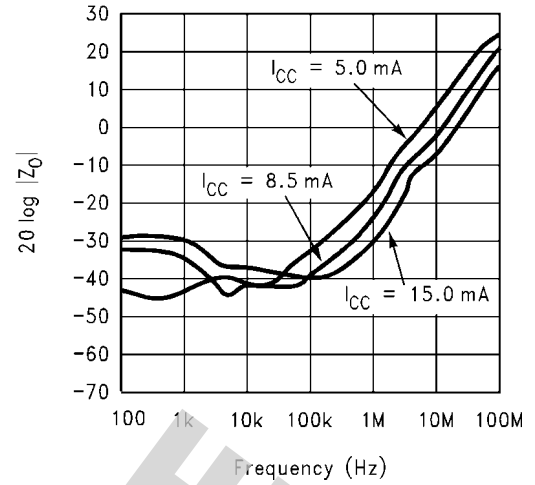

1270812

CMRR vs. Common-Mode Input Voltage

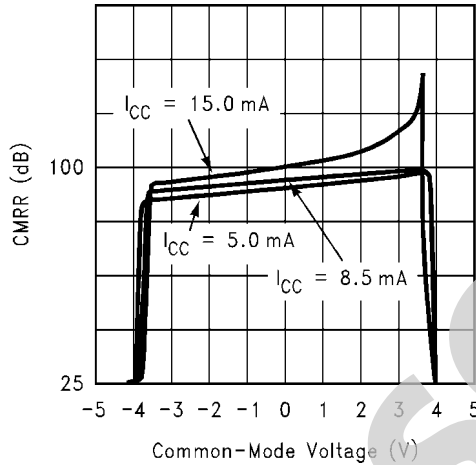

1270813

Common-Mode Input Transimpedance

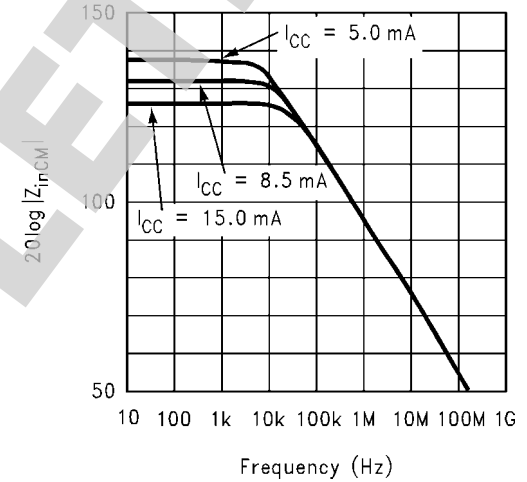

1270814

Differential Input Impedance

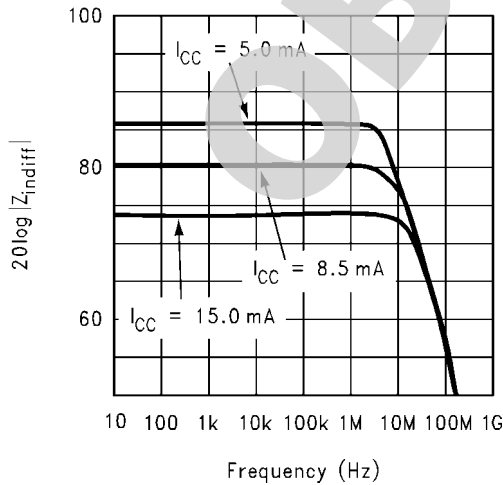

1270815

Pulse Response ($V_{O1} = V_{PP}$)

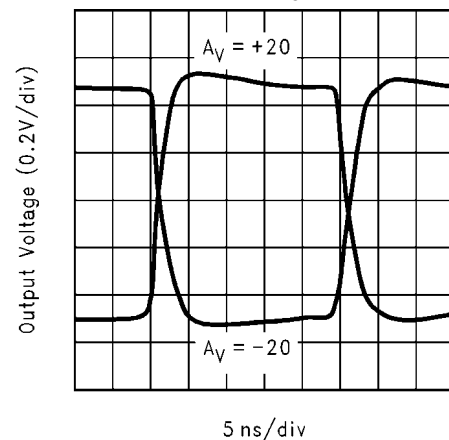

1270816

Large Signal Pulse Response ($V_{O1} = V_{pp}$)

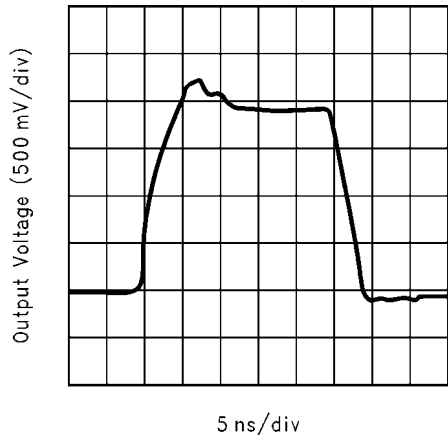

1270817

Settling Time vs. Gain

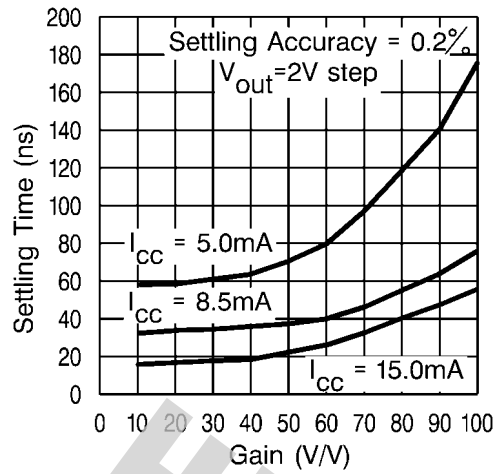

1270818

Short Term Settling Time

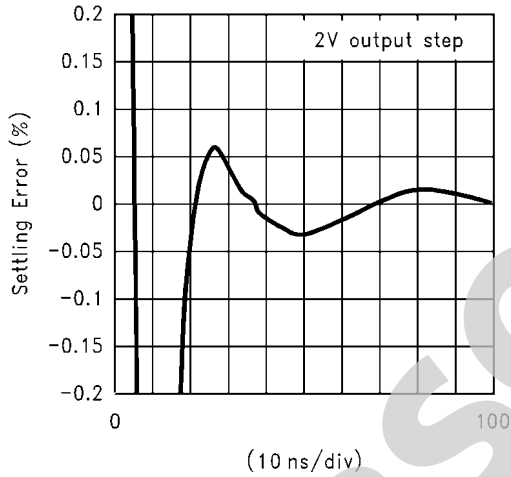

1270819

Long Term Settling Time

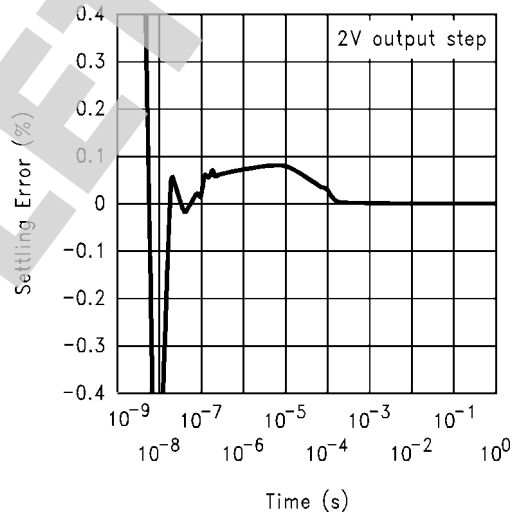

1270820

Settling Time vs. C_L and R_S

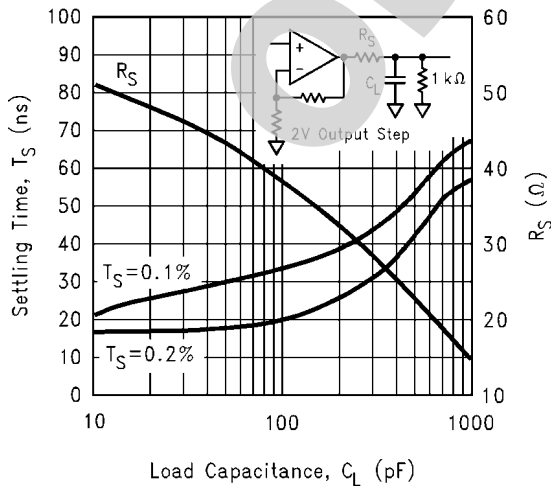

1270821

Supply Current Range vs. R_p

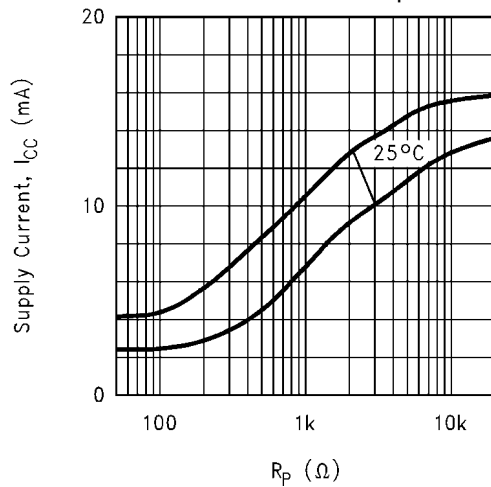

1270822

Gain-Bandwidth Product vs. I_{CC}

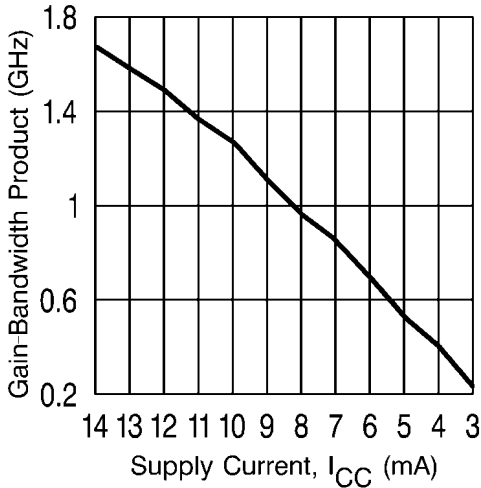

1270823

Differential Gain and Phase (4.43MHz)

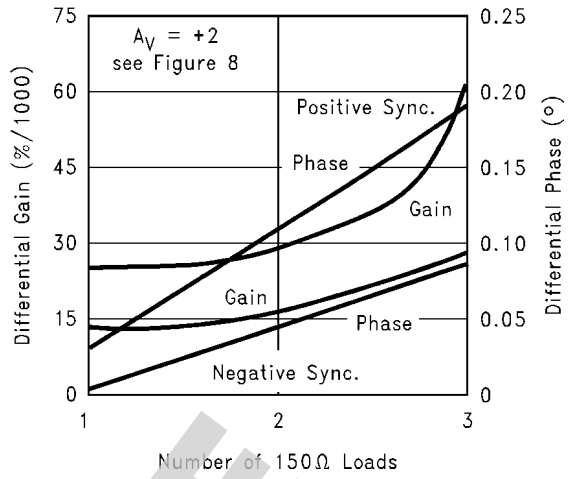

1270824

2nd and 3rd Harmonic Distortion ($V_{O1} = V_{PP}$)

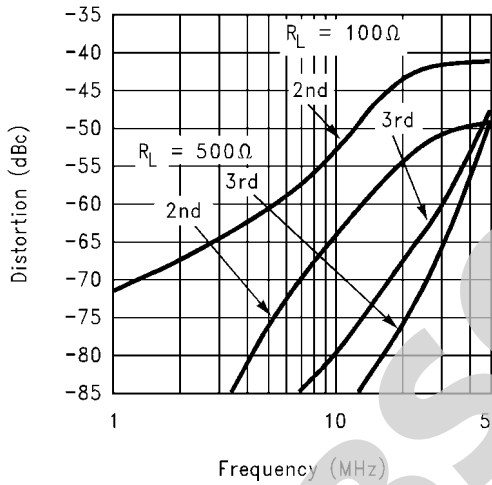

1270825

Distortion vs. Gain & I_{CC} ($V_{O1} = V_{PP}$ $f_O = 3MHz$)

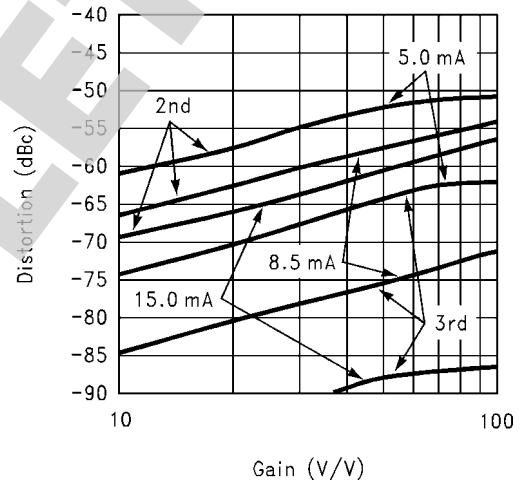

1270826

2-Tone, 3rd Order Intermodulation Intercept

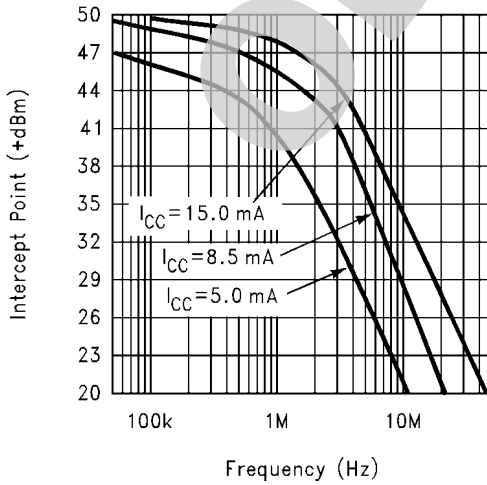

1270827

Output Voltage vs. Load

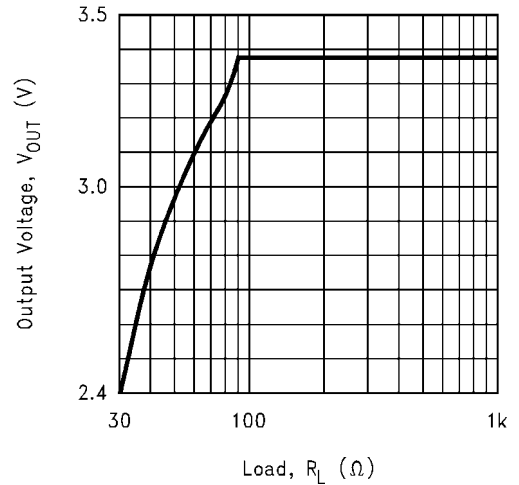

1270828

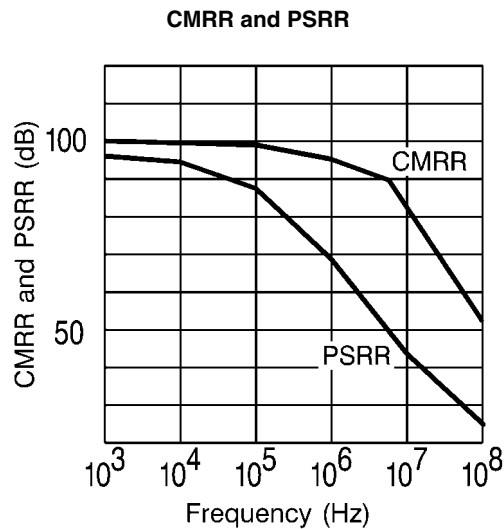

1270829

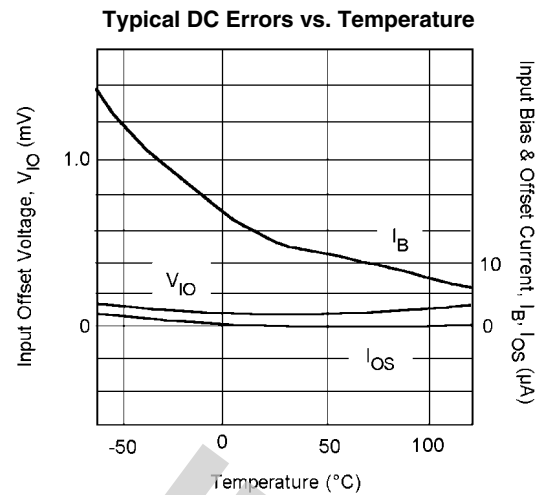

1270830

Application Division

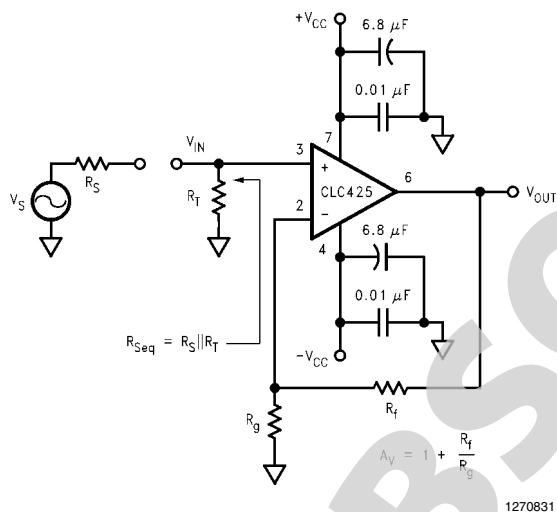

1270831

FIGURE 1. Non-Inverting Amplifier Configuration

Introduction

The CLC425 is a very wide gain bandwidth, ultra low noise voltage feedback operational amplifier which enables application areas such as medical diagnostic ultrasound, magnetic tape & disk storage and fiber-optics to achieve maximum high frequency signal-to-noise ratios. The set of characteristic plots located in the "Typical Performance" section illustrates many of the performance trade offs. The following discussion will enable the proper selection of external components in order to achieve optimum device performance.

Bias Current Cancellation

In order to cancel the bias current errors of the non-inverting configuration, the parallel combination of the gain setting (R_g) and feedback (R_f) resistors should equal the equivalent source resistance (R_{seq}) as defined in Figure 1. Combining this constraint with the non-inverting gain equation also seen in Figure 1, allows both R_f and R_g to be determined explicitly from the following equations:

$$R_f = A_V R_{seq} \text{ and } R_g = R_f / (A_V - 1).$$

When driven from a 0Ω source, such as that from the output of an op amp, the non-inverting input of the CLC425 should be isolated with at least a 25Ω series resistor.

As seen in Figure 2, bias current cancellation is accomplished for the inverting configuration by placing a resistor (R_b) on the non-inverting input equal in value to the resistance seen by the inverting input ($R_f (R_g + s)$). R_b is recommended to be no less than 25Ω for best CLC425 performance. The additional noise contribution of R_b can be minimized through the use of a shunt capacitor.

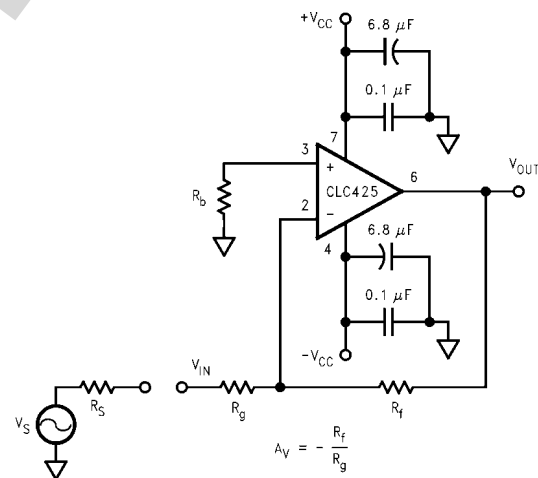

1270834

FIGURE 2. Inverting Amplifier Configuration

Total Input Noise vs. Source Resistance

In order to determine maximum signal-to-noise ratios from the CLC425, an understanding of the interaction between the amplifier's intrinsic noise sources and the noise arising from its external resistors is necessary.

Figure 3 describes the noise model for the non-inverting amplifier configuration showing all noise sources. In addition to the intrinsic input voltage noise (e_n) and current noise ($i_n = i_{n+} = i_{n-}$) sources, there also exists thermal voltage noise ($e_t = \sqrt{Hz4kTR}$)

associated with each of the external resistors. Equation 1 provides the general form for total equivalent input voltage noise density (e_{ni}). Equation 2 is a simplification of Equation 1 that assumes

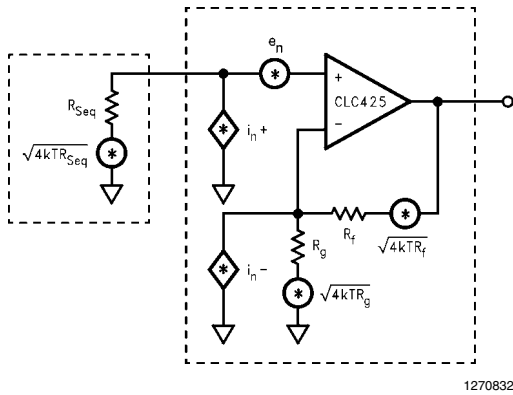

FIGURE 3. Non-inverting Amplifier Noise Model

$$e_{ni} = \sqrt{e_n^2 + (i_{n+} R_{seq})^2 + 4kTR_{seq} + (i_{n-} (R_f \parallel R_g))^2 + 4kT(R_f \parallel R_g)} \quad (1)$$

$R_f R_g = R_{seq}$ for bias current cancellation. Figure 4 illustrates the equivalent noise model using this assumption. Figure 5 is a plot of e_{ni} against equivalent source resistance (R_{seq}) with all of the contributing voltage noise source of Equation 2 shown. This plot gives the expected e_{ni} for a given (R_{seq}) which assumes $R_f R_g = R_{seq}$ for bias current cancellation. The total equivalent output voltage noise (e_{no}) is $e_{ni} \cdot A_v$.

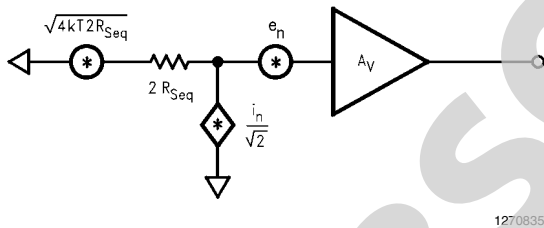

FIGURE 4. Noise Model with $R_f R_g = R_{seq}$

$$e_{ni} = \sqrt{e_n^2 + 2(i_n R_{seq})^2 + 4kT(2R_{seq})} \quad (2)$$

As seen in Figure 5, e_{ni} is dominated by the intrinsic voltage noise (e_n) of the amplifier for equivalent source resistances below 33.5Ω. Between 33.5Ω and 6.43kΩ, e_{ni} is dominated by the thermal noise ($e_t = \sqrt{Hz 4kTR_{seq}}$) of the external resistor. Above 6.43kΩ, e_{ni} is dominated by the amplifier's current noise ($\sqrt{Hz 2i_n R_{seq}}$). The point at which the CLC425's voltage noise and current noise contribute equally occurs for $R_{seq} = 464\Omega$ (i.e., $e_n / \sqrt{Hz 2i_n}$). As an example, configured with a gain of +20V/V giving a -3dB of 90MHz and driven from an $R_{seq} = 25\Omega$, the CLC425 produces a total equivalent input noise voltage ($e_{ni} \times \sqrt{Hz 1.57 \cdot 90MHz}$) of 16.5μV_{rms}.

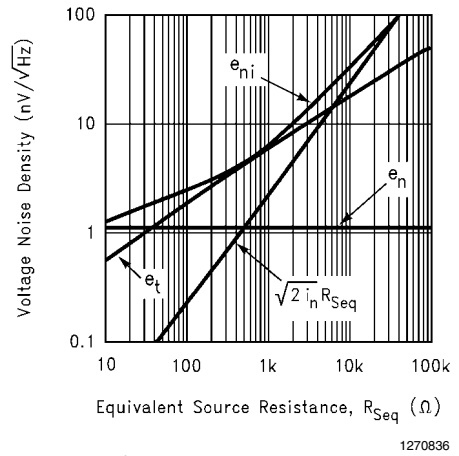

FIGURE 5. Voltage Noise Density vs. Source Resistance

If bias current cancellation is not a requirement, then $R_f R_g$ does not need to equal R_{seq} in this case, according to Equation 1, $R_f R_g$ should be as low as possible in order to minimize noise. Results similar to Equation 1 are obtained for the inverting configuration of Figure 2 if R_{seq} is replaced by R_b and R_g is replaced by $R_g + R_s$. With these substitutions, Equation 1 will yield an e_{ni} referred to the non-inverting input. Referring e_{ni} to the inverting input is easily accomplished by multiplying e_{ni} by the ratio of non-inverting to inverting gains.

Noise Figure

Noise Figure (NF) is a measure of the noise degradation caused by an amplifier.

$$NF = 10 \text{LOG} \left\{ \frac{S_i / N_i}{S_o / N_o} \right\} = 10 \text{LOG} \left\{ \frac{e_{ni}^2}{e_t^2} \right\} \quad (3)$$

The Noise Figure formula is shown in Equation 3. The addition of a terminating resistor R_T , reduces the external thermal noise but increases the resulting NF. The NF is increased because R_T reduces the input signal amplitude thus reducing the input SNR.

$$NF = 10 \text{LOG} \left(\frac{e_n^2 + i_n^2 (R_{seq} + (R_f \parallel R_g))^2 + 4kTR_{seq} + 4kT(R_f \parallel R_g)}{4kTR_{seq}} \right) \quad (4)$$

The noise figure is related to the equivalent source resistance (R_{seq}) and the parallel combination of R_f and R_g . To minimize noise figure, the following steps are recommended:

- Minimize $R_f R_g$
- Choose the Optimum R_S (R_{OPT})

R_{OPT} is the point at which the NF curve reaches a minimum and is approximated by:

$$R_{OPT} \approx e_n / i_n$$

Figure 6 is a plot of NF vs R_s with $R_f R_g = 9.09 (A_v = +10)$. The NF curves for both Underterminated and Terminated systems are shown. The Terminated curve assumes $R_s = R_T$. The table indicates the NF for various source resistances including $R_s = R_{OPT}$.

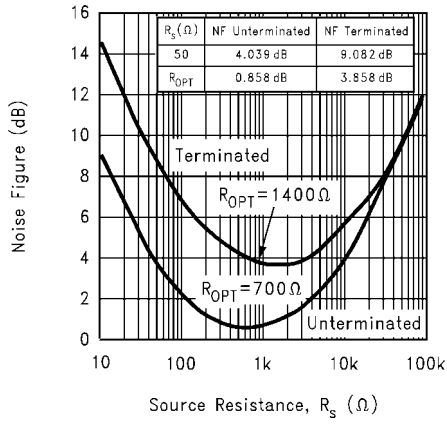

FIGURE 6. Noise Figure vs. Source Resistance

Supply Current Adjustment

The CLC425's supply current can be externally adjusted downward from its nominal value by adding an optional resistor (R_p) between pin 8 and the negative supply as shown in Figure 7. Several of the plots found within the plot pages demonstrate the CLC425's behavior at different supply currents. The plot labeled " I_{cc} vs R_p " provides the means for selecting R_p and shows the results of standard IC process variation which is bounded by the 25°C curve.

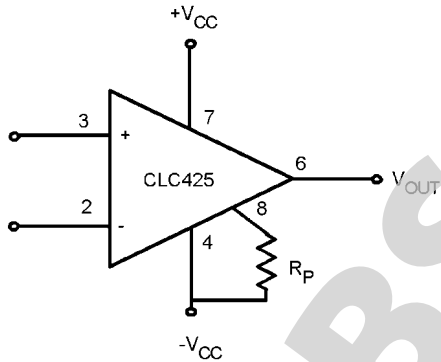

FIGURE 7. External Supply Current Adjustment

Non-Inverting Gains Less Than 10V/V

Using the CLC425 at lower non-inverting gains requires external compensation such as the shunt compensation as shown in Figure 8. The quiescent supply current must also be reduced to 5mA with R_p for stability. The compensation capacitors are chosen to reduce frequency response peaking to less than 1dB. The plot in the "Typical Performance" section labeled "differential gain and Phase" shows the video performance of the CLC425 with this compensation circuitry.

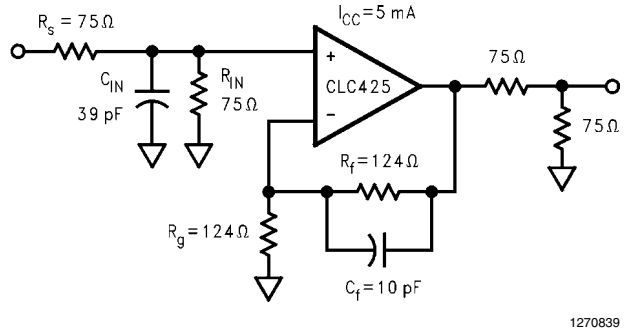

FIGURE 8. External Shunt Compensation

Inverting Gains Less Than 10V/V

The lag compensation of Figure 9 will achieve stability for lower gains. Placing the network between the two input terminals does not affect the closed-loop nor noise gain, but is best used for the inverting configuration because of its effect on the non-inverting input impedance.

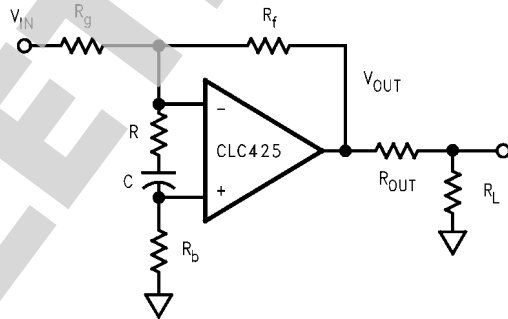

FIGURE 9. External Lag Compensation

Single-Supply Operation

The CLC425 can be operated with single power supply as shown in Figure 10. Both the input and output are capacitively coupled to set the dc operating point.

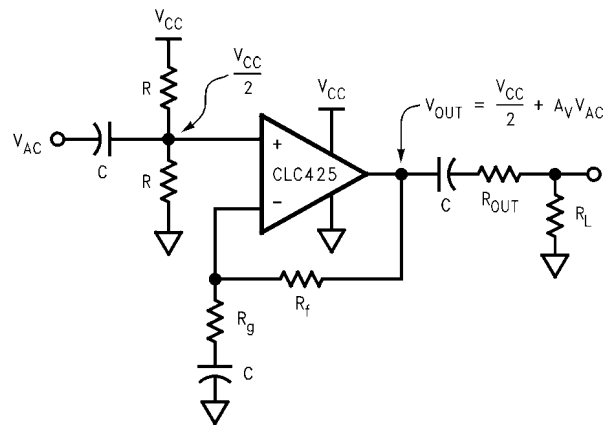

FIGURE 10. Single Supply Operation

Low Noise Transimpedance Amplifier

The circuit of Figure 11 implements a low-noise transimpedance amplifier commonly used with photo-diodes. The transimpedance gain is set by R_f . The simulated frequency

response is shown in *Figure 12* and shows the influence C_f has over gain flatness. Equation 4 provides the total input current noise density (i_{ni}) equation for the basic transimpedance configuration and is plotted against feedback resistance (R_f) showing all contributing noise sources in *Figure 13*. This plot indicates the expected total equivalent input current noise density (i_{ni}) for a given feedback resistance (R_f). The total equivalent output voltage noise density (e_{no}) is $i_{ni} * R_f$.

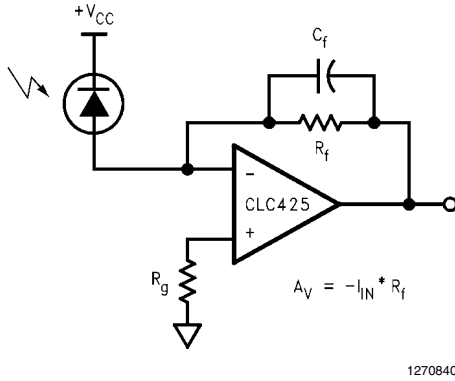

FIGURE 11. Transimpedance Amplifier Configuration

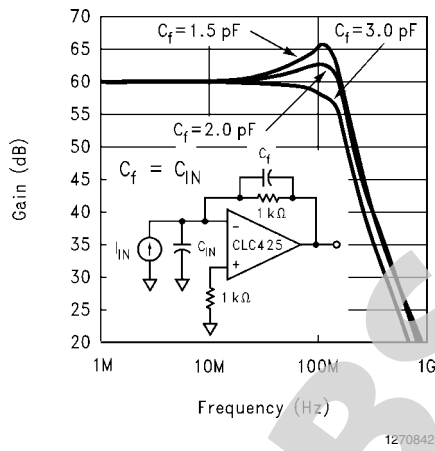

FIGURE 12. Transimpedance Amplifier Frequency Response

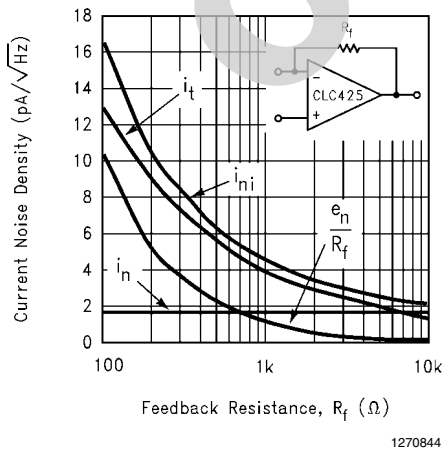

FIGURE 13. Current Noise Density vs. Feedback Resistance

$$i_{ni} = \sqrt{i_n^2 + \left(\frac{e_n}{R_f}\right)^2 + \frac{4kT}{R_f}} \quad (5)$$

Very Low Noise Figure Amplifier

The circuit of *Figure 14* implements a very low Noise Figure amplifier using a step-up transformer combined with a CLC425 and a CLC404. The circuit is configured with a gain of 35.6dB. The circuit achieves measured Noise Figures of less than 2.5dB in the 10-40MHz region, 3rd order intercepts exceed +30dB for frequencies less than 40MHz and gain flatness of 0.5dB is measured in the 1-50MHz passbands. Application Note OA-14 provides greater detail on these low Noise Figure techniques.

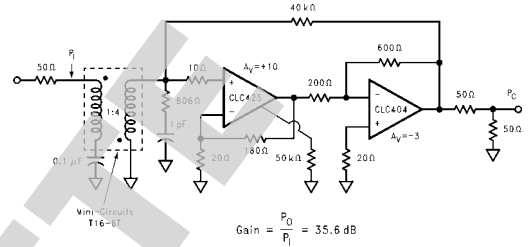

FIGURE 14. Very Noise Figure Amplifier

Low Noise Integrator

The CLC425 implements a deBoo integrator shown in *Figure 15*. Integration linearity is maintained through positive feedback. The CLC425's low input offset voltage and matched inputs allowing bias current cancellation provide for very precise integration. Stability is maintained through the constraint on the circuit elements.

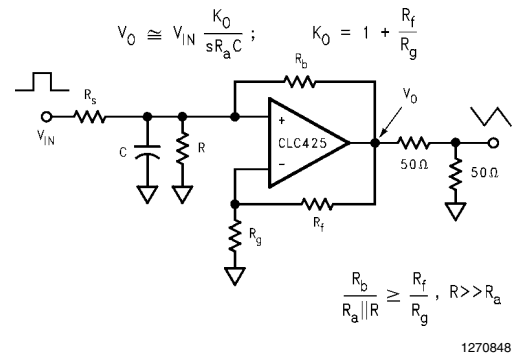
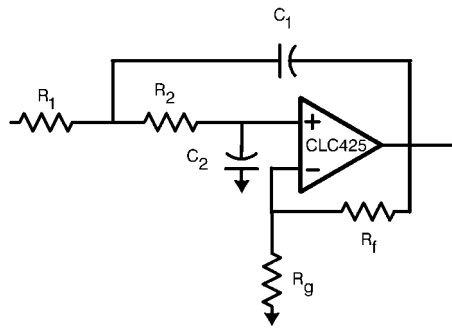

FIGURE 15. Low Noise Integrator

High-Gain Sallen-Key Active Filters

The CLC425 is well suited for high gain Sallen-Key type of active filters. *Figure 16* shows the 2ndorder Sallen-Key low pass filter topology. Using component predistortion methods as discussed in OA-21 enables the proper selection of components for these high-frequency filters.



1270856

FIGURE 16. Sallen-Key Active Filter Topology

Low Noise Magnetic Media Equalizer

The CLC425 implements a high-performance low noise equalizer for such applications as magnetic tape channels as shown in Figure 17. The circuit combines an integrator with a bandpass filter to produce the low noise equalization. The circuit's simulated frequency response is illustrated in Figure 18.

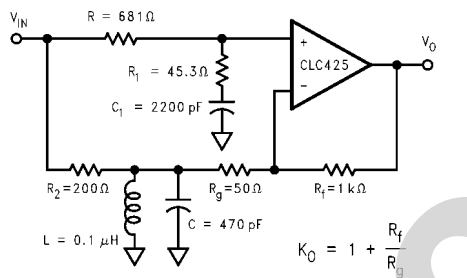

$$K_0 = 1 + \frac{R_f}{R_g}$$

$$\frac{V_O}{V_{IN}} = K_0 \left(\frac{sC_1 R_1 + 1}{sC_1 (R_1 + R) + 1} - \left(\frac{R_f}{R_f + R_g} \right) \frac{sLR_g}{s^2 LCR_2 R_g + sL(R_2 + R_g) + R_2 R_g} \right)$$

1270847

FIGURE 17. Low Noise Magnetic Media Equalizer

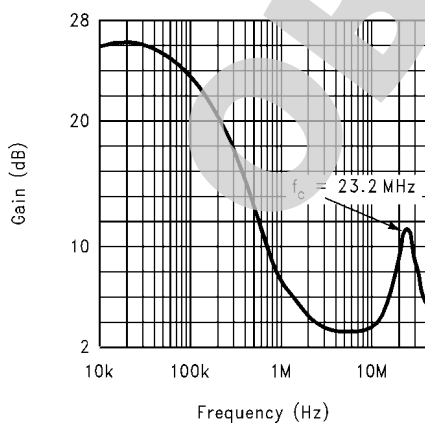

1270849

FIGURE 18. Equalizer Frequency Response

Low-Noise Phase-Locked Loop Filter

The CLC425 is extremely useful as a Phase-Locked Loop filter in such applications as frequency synthesizers and data synchronizers. The circuit of Figure 19 implements one possible PLL filter with the CLC425.

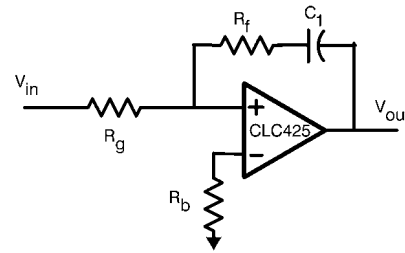

1270857

FIGURE 19. Phase-Locked Loop Filter

Decreasing the Input Noise Voltage

The input noise voltage of the CLC425 can be reduced from its already low 1.05nV/√Hz by slightly increasing the supply current. Using a 50kΩ resistor to ground on pin 8, as shown in the circuit of Figure 14, will increase the quiescent current to ≈17mA and reduce the input noise voltage to <0.95nV/√Hz.

Printed Circuit Board Layout

Generally, a good high-frequency layout will keep power supply and ground traces away from the inverting input and output pins. Parasitic capacitances on these nodes to ground will cause frequency response peaking and possible circuit oscillation, see OA-15 for more information. National suggests the CLC730013-DIP, CLC730027-SOIC, or CLC730068-SOT evaluation board as a guide for high frequency layout and as an aid in device testing and characterization.

Physical Dimensions inches (millimeters) unless otherwise noted

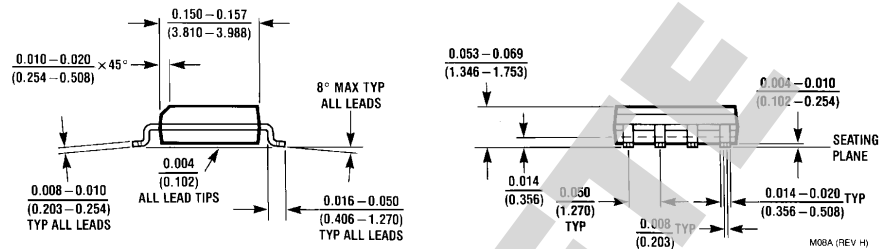
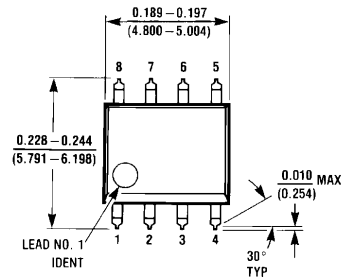

8-Pin SOIC
NS Package Number M08A

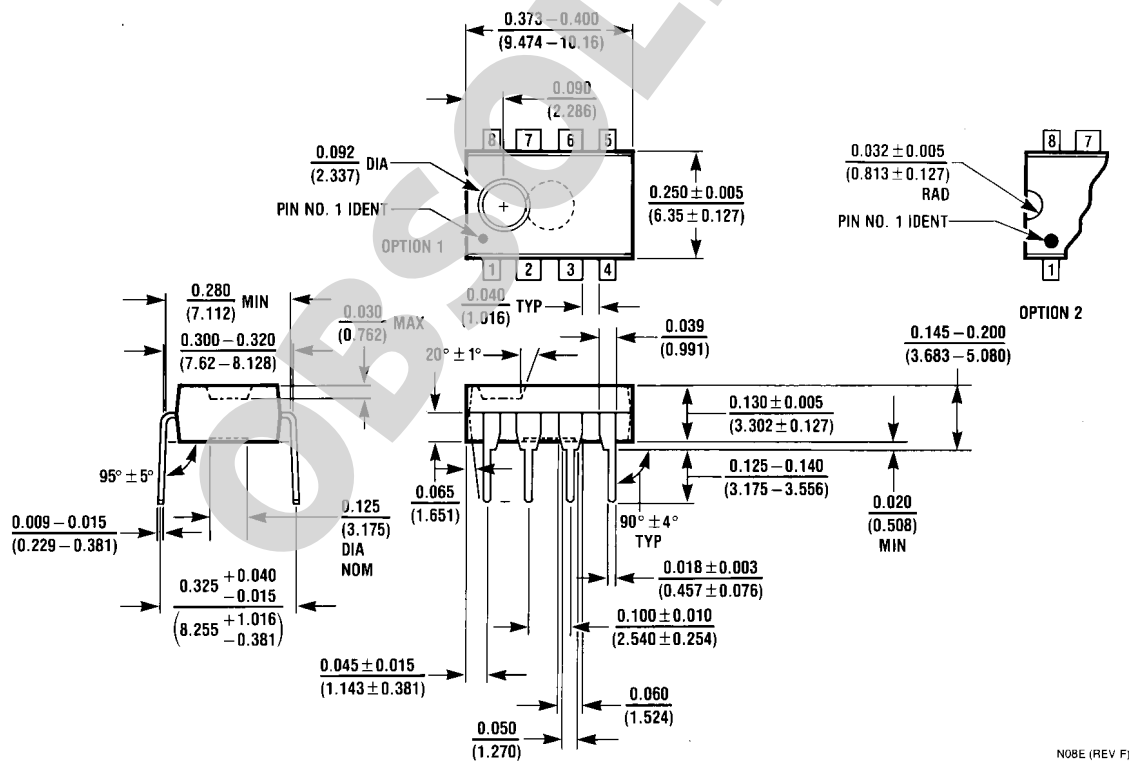

8-Pin MDIP
NS Package Number N08E

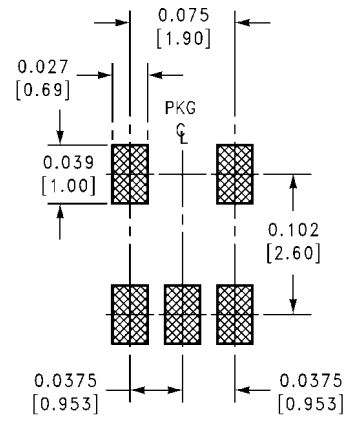
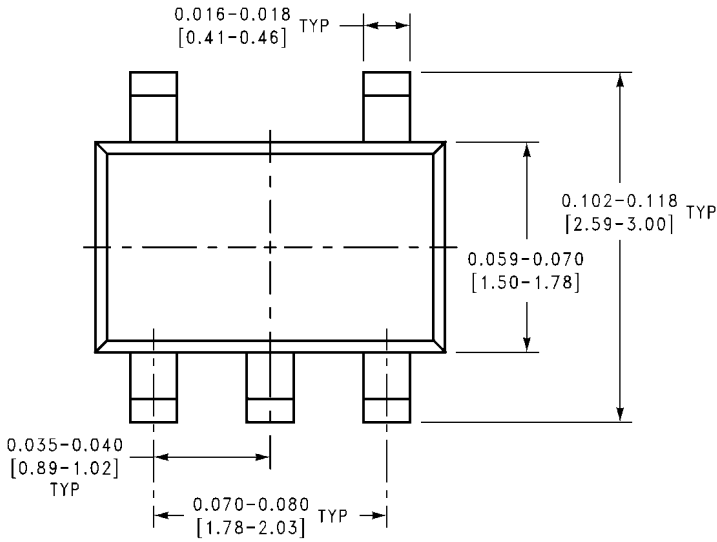

LAND PATTERN RECOMMENDATION

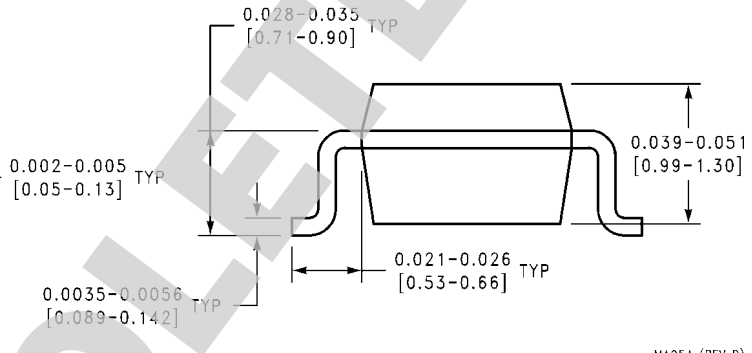
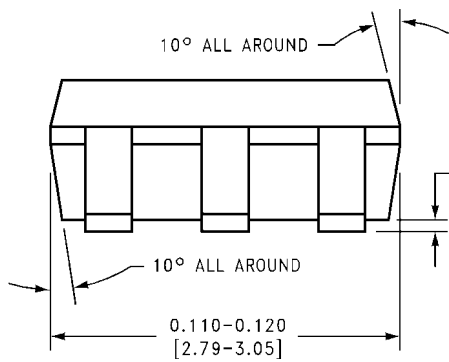

5-Pin SOT23
NS Package Number MA05A

MA05A (REV D)

OBSOLETE

Notes

For more National Semiconductor product information and proven design tools, visit the following Web sites at:

Products		Design Support	
Amplifiers	www.national.com/amplifiers	WEBENCH® Tools	www.national.com/webench
Audio	www.national.com/audio	App Notes	www.national.com/appnotes
Clock and Timing	www.national.com/timing	Reference Designs	www.national.com/refdesigns
Data Converters	www.national.com/adc	Samples	www.national.com/samples
Interface	www.national.com/interface	Eval Boards	www.national.com/evalboards
LVDS	www.national.com/lvds	Packaging	www.national.com/packaging
Power Management	www.national.com/power	Green Compliance	www.national.com/quality/green
Switching Regulators	www.national.com/switchers	Distributors	www.national.com/contacts
LDOs	www.national.com/ldo	Quality and Reliability	www.national.com/quality
LED Lighting	www.national.com/led	Feedback/Support	www.national.com/feedback
Voltage Reference	www.national.com/vref	Design Made Easy	www.national.com/easy
PowerWise® Solutions	www.national.com/powerwise	Solutions	www.national.com/solutions
Serial Digital Interface (SDI)	www.national.com/sdi	Mil/Aero	www.national.com/milaero
Temperature Sensors	www.national.com/tempensors	SolarMagic™	www.national.com/solarmagic
Wireless (PLL/VCO)	www.national.com/wireless	PowerWise® Design University	www.national.com/training

THE CONTENTS OF THIS DOCUMENT ARE PROVIDED IN CONNECTION WITH NATIONAL SEMICONDUCTOR CORPORATION ("NATIONAL") PRODUCTS. NATIONAL MAKES NO REPRESENTATIONS OR WARRANTIES WITH RESPECT TO THE ACCURACY OR COMPLETENESS OF THE CONTENTS OF THIS PUBLICATION AND RESERVES THE RIGHT TO MAKE CHANGES TO SPECIFICATIONS AND PRODUCT DESCRIPTIONS AT ANY TIME WITHOUT NOTICE. NO LICENSE, WHETHER EXPRESS, IMPLIED, ARISING BY ESTOPPEL OR OTHERWISE, TO ANY INTELLECTUAL PROPERTY RIGHTS IS GRANTED BY THIS DOCUMENT.

TESTING AND OTHER QUALITY CONTROLS ARE USED TO THE EXTENT NATIONAL DEEMS NECESSARY TO SUPPORT NATIONAL'S PRODUCT WARRANTY. EXCEPT WHERE MANDATED BY GOVERNMENT REQUIREMENTS, TESTING OF ALL PARAMETERS OF EACH PRODUCT IS NOT NECESSARILY PERFORMED. NATIONAL ASSUMES NO LIABILITY FOR APPLICATIONS ASSISTANCE OR BUYER PRODUCT DESIGN. BUYERS ARE RESPONSIBLE FOR THEIR PRODUCTS AND APPLICATIONS USING NATIONAL COMPONENTS. PRIOR TO USING OR DISTRIBUTING ANY PRODUCTS THAT INCLUDE NATIONAL COMPONENTS, BUYERS SHOULD PROVIDE ADEQUATE DESIGN, TESTING AND OPERATING SAFEGUARDS.

EXCEPT AS PROVIDED IN NATIONAL'S TERMS AND CONDITIONS OF SALE FOR SUCH PRODUCTS, NATIONAL ASSUMES NO LIABILITY WHATSOEVER, AND NATIONAL DISCLAIMS ANY EXPRESS OR IMPLIED WARRANTY RELATING TO THE SALE AND/OR USE OF NATIONAL PRODUCTS INCLUDING LIABILITY OR WARRANTIES RELATING TO FITNESS FOR A PARTICULAR PURPOSE, MERCHANTABILITY, OR INFRINGEMENT OF ANY PATENT, COPYRIGHT OR OTHER INTELLECTUAL PROPERTY RIGHT.

LIFE SUPPORT POLICY

NATIONAL'S PRODUCTS ARE NOT AUTHORIZED FOR USE AS CRITICAL COMPONENTS IN LIFE SUPPORT DEVICES OR SYSTEMS WITHOUT THE EXPRESS PRIOR WRITTEN APPROVAL OF THE CHIEF EXECUTIVE OFFICER AND GENERAL COUNSEL OF NATIONAL SEMICONDUCTOR CORPORATION. As used herein:

Life support devices or systems are devices which (a) are intended for surgical implant into the body, or (b) support or sustain life and whose failure to perform when properly used in accordance with instructions for use provided in the labeling can be reasonably expected to result in a significant injury to the user. A critical component is any component in a life support device or system whose failure to perform can be reasonably expected to cause the failure of the life support device or system or to affect its safety or effectiveness.

National Semiconductor and the National Semiconductor logo are registered trademarks of National Semiconductor Corporation. All other brand or product names may be trademarks or registered trademarks of their respective holders.

Copyright© 2009 National Semiconductor Corporation

For the most current product information visit us at www.national.com

 **National Semiconductor Americas Technical Support Center**
 Email: support@nsc.com
 Tel: 1-800-272-9959

National Semiconductor Europe Technical Support Center
 Email: europe.support@nsc.com

National Semiconductor Asia Pacific Technical Support Center
 Email: ap.support@nsc.com

National Semiconductor Japan Technical Support Center
 Email: jpn.feedback@nsc.com