

LMP8645/LMP8645HV

Precision High Voltage Current Sense Amplifier

General Description

The LMP8645 and the LMP8645HV are precision current sense amplifiers that detect small differential voltages across a sense resistor in the presence of high input common mode voltages with a supply voltage Range from 2.7V to 12V.

The LMP8645 accepts input signals with common mode voltage Range from -2V to 42V, while the LMP8645HV accepts input signal with common mode voltage Range from -2V to 76V. The LMP8645 and LMP8645HV have adjustable gain for applications where supply current and high common mode voltage are the determining factors. The gain is configured with a single resistor, providing a high level of flexibility, the accuracy could be as low as 2% (max) including the gain setting resistor. The output is buffered in order to provide low output impedance. This high side current sense amplifier is ideal for sensing and monitoring currents in DC or battery powered systems, excellent AC and DC specifications over temperature, and keeps errors in the current sense loop to a minimum. The LMP8645 is an ideal choice for industrial, automotive and consumer applications, and it is available in TSOT-6 package.

Features

Typical values, $T_A = 25^\circ\text{C}$

- High common-mode voltage Range
 - LMP8645 -2V to 42V
 - LMP8645HV -2V to 76V
- Supply voltage Range 2.7V to 12V
- Gain configurable with a single resistor
- Max variable gain accuracy (with external resistor) 2.0%
- Transconductance 200 $\mu\text{A/V}$
- Low offset voltage 1 mV
- Input bias 12 μA
- PSRR 90 dB
- CMRR 95 dB
- Temperature Range -40°C to 125°C
- 6-Pin TSOT Package

Applications

- High-side current sense
- Vehicle current measurement
- Motor controls
- Battery monitoring
- Remote sensing
- Power management

Typical Application

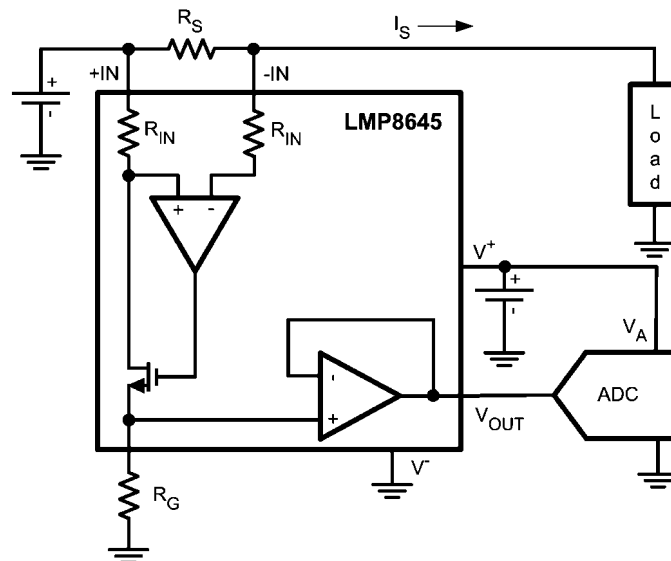

Absolute Maximum Ratings *(Note 1)*

If Military/Aerospace specified devices are required, please contact the National Semiconductor Sales Office/ Distributors for availability and specifications.

ESD Tolerance *(Note 2)*

Human Body Model

For input pins +IN, -IN $\pm 5000V$

For all other pins $\pm 2000V$

Machine Model 200V

Charge device model 1250V

Supply Voltage ($V_S = V^+ - V^-$) 13.2V

Differential voltage +IN- (-IN) 6V

Voltage at pins +IN, -IN

LMP8645HV -6V to 80V

LMP8645 -6V to 60V

Voltage at R_G pin 13.2V

Voltage at OUT pin V^- to V^+

Storage Temperature Range -65°C to 150°C

Junction Temperature *(Note 3)* 150°C

For soldering specifications,

see product folder at www.national.com and

www.national.com/ms/MS/MS-SOLDERING.pdf

Operating Ratings *(Note 1)*

Supply Voltage ($V_S = V^+ - V^-$) 2.7V to 12V

Temperature Range *(Note 3)* -40°C to 125°C

Package Thermal Resistance *(Note 3)*

TSOT-6 96°C/W

2.7V Electrical Characteristics *(Note 4)*

Unless otherwise specified, all limits guaranteed for at $T_A = 25^\circ\text{C}$, $V_S = V^+ - V^-$, $V^+ = 2.7V$, $V^- = 0V$, $-2V < V_{CM} < 76V$, $R_G = 25k\Omega$, $R_L = 10M\Omega$. **Boldface** limits apply at the temperature extremes.

Symbol	Parameter	Condition	Min <i>(Note 6)</i>	Typ <i>(Note 5)</i>	Max <i>(Note 6)</i>	Units
V_{OS}	Input Offset Voltage	$V_{CM} = 2.1V$	-1 -1.7		1 1.7	mV
TCV_{OS}	Input Offset Voltage Drift <i>(Note 7, Note 9)</i>	$V_{CM} = 2.1V$			7	$\mu\text{V}/^\circ\text{C}$
I_B	Input Bias Current <i>(Note 10)</i>	$V_{CM} = 2.1V$		12	20	μA
e_{ni}	Input Voltage Noise <i>(Note 9)</i>	$f > 10\text{ kHz}$, $R_G = 5\text{ k}\Omega$		120		$\text{nV}/\sqrt{\text{Hz}}$
$V_{SENSE(MAX)}$	Max Input Sense Voltage <i>(Note 9)</i>	$V_{CM} = 12V$, $R_G = 5\text{ k}\Omega$		600		mV
Gain A_V	Adjustable Gain Setting <i>(Note 9)</i>	$V_{CM} = 12V$	1		100	V/V
G_m	Transconductance	$V_{CM} = 2.1V$		200		$\mu\text{A}/V$
	Accuracy	$V_{CM} = 2.1V$	-2 -3.4		2 3.4	%
	Gm drift <i>(Note 9)</i>	-40°C to 125°C, $V_{CM} = 2.1V$			140	ppm /°C
PSRR	Power Supply Rejection Ratio	$V_{CM} = 2.1V$, $2.7V < V^+ < 12V$	90			dB
CMRR	Common Mode Rejection Ratio	LMP8645HV $2.1V < V_{CM} < 76V$	95			dB
		LMP8645 $2.1V < V_{CM} < 42V$				
BW	-3 dB Bandwidth <i>(Note 9)</i>	$R_G = 10\text{ k}\Omega$, $C_G = 4\text{ pF}$, $V_{SENSE} = 400\text{ mV}$, $C_L = 30\text{ pF}$, $R_L = 1M\Omega$		990		kHz
		$R_G = 25\text{ k}\Omega$, $C_G = 4\text{ pF}$, $V_{SENSE} = 200\text{ mV}$, $C_L = 30\text{ pF}$, $R_L = 1M\Omega$		260		
		$R_G = 50k\Omega$, $C_G = 4\text{ pF}$, $V_{SENSE} = 100\text{ mV}$, $C_L = 30\text{ pF}$, $R_L = 1M\Omega$		135		
SR	Slew Rate <i>(Note 8, Note 9)</i>	$V_{CM} = 5V$, $C_G = 4\text{ pF}$, V_{SENSE} from 25 mV to 175 mV, $C_L = 30\text{ pF}$, $R_L = 1M\Omega$		0.5		V/ μs
I_S	Supply Current	$V_{CM} = 2.1V$		380	525 710	μA
		$V_{CM} = -2V$		2000	2500 2700	
V_{OUT}	Maximum Output Voltage	$V_{CM} = 2.1V$, $R_G = 500\text{ k}\Omega$	1.2			V
	Minimum Output Voltage	$V_{CM} = 2.1V$			20	mV

Symbol	Parameter	Condition	Min (Note 6)	Typ (Note 5)	Max (Note 6)	Units
I _{OUT}	Output current (Note 9)	Sourcing, V _{OUT} = 600mV, R _G = 150kΩ		5		mA
		Sinking, V _{OUT} = 600mV, R _G = 150kΩ		5		
C _{LOAD}	Max Output Capacitance Load (Note 9)			30		pF

5V Electrical Characteristics (Note 4)

Unless otherwise specified, all limits guaranteed for at T_A = 25°C, V_S=V⁺-V⁻, V⁺ = 5V, V⁻ = 0V, -2V < V_{CM} < 76V, R_G= 25kΩ, R_L = 10 MΩ. **Boldface** limits apply at the temperature extremes.

Symbol	Parameter	Condition	Min (Note 6)	Typ (Note 5)	Max (Note 6)	Units
V _{OS}	Input Offset Voltage	V _{CM} = 2.1V	-1 -1.7		1 1.7	mV
TCV _{OS}	Input Offset Voltage Drift (Note 7, Note 9)	V _{CM} = 2.1V			7	μV/°C
I _B	Input Bias Current (Note 10)	V _{CM} = 2.1V		12.5	22	μA
e _{ni}	Input Voltage Noise (Note 9)	f > 10 kHz, R _G = 5 kΩ		120		nV/√Hz
V _{SENSE(MAX)}	Max Input Sense Voltage (Note 9)	V _{CM} = 12V, R _G = 5 kΩ		600		mV
Gain A _V	Adjustable Gain Setting (Note 9)	V _{CM} = 12V	1		100	V/V
G _m	Transconductance	V _{CM} = 2.1V		200		μA/V
	Accuracy	V _{CM} = 2.1V	-2 -3.4		2 3.4	%
	G _m drift (Note 9)	-40°C to 125°C, V _{CM} = 2.1V			140	ppm/°C
PSRR	Power Supply Rejection Ratio	V _{CM} = 2.1V, , 2.7V < V ⁺ < 12V	90			dB
CMRR	Common Mode Rejection Ratio	LMP8645HV 2.1V < V _{CM} < 76V	95			dB
		LMP8645 2.1V < V _{CM} < 42V -2V < V _{CM} < 2V	60			
BW	-3 dB Bandwidth (Note 9)	R _G = 10 kΩ, C _G = 4 pF, V _{SENSE} = 400 mV, C _L = 30 pF, R _L = 1MΩ		850		kHz
		R _G = 25 kΩ, C _G = 4 pF, V _{SENSE} = 300 mV, C _L = 30 pF, R _L = 1MΩ		260		
		R _G = 50 kΩ, C _G = 4 pF, V _{SENSE} = 300mV, C _L = 30 pF, R _L = 1MΩ		140		
SR	Slew Rate (Note 8, Note 9)	V _{CM} = 5V, C _G = 4 pF, V _{SENSE} from 100 mV to 500 mV, C _L = 30 pF, R _L = 1MΩ		0.5		V/μs
I _S	Supply Current	V _{CM} = 2.1V		450	610 780	μA
		V _{CM} = -2V		2100	2800 3030	
V _{OUT}	Maximum Output Voltage	V _{CM} = 5V, R _G = 500 kΩ	3.3			V
	Minimum Output Voltage	V _{CM} = 2.1V			22	mV
I _{OUT}	Output current (Note 9)	Sourcing, V _{OUT} = 1.65V, R _G = 150kΩ		5		mA
		Sinking, V _{OUT} = 1.65V, R _G = 150kΩ		5		
C _{LOAD}	Max Output Capacitance Load (Note 9)			30		pF

12V Electrical Characteristics (Note 4)

Unless otherwise specified, all limits guaranteed for at $T_A = 25^\circ\text{C}$, $V_S = V^+ - V^-$, $V^+ = 12\text{V}$, $V^- = 0\text{V}$, $-2\text{V} < V_{\text{CM}} < 76\text{V}$, $R_G = 25\text{k}\Omega$, $R_L = 10\text{M}\Omega$. **Boldface** limits apply at the temperature extremes.

Symbol	Parameter	Condition	Min (Note 6)	Typ (Note 5)	Max (Note 6)	Units
V_{OS}	Input Offset Voltage	$V_{\text{CM}} = 2.1\text{V}$	-1 -1.7		1 1.7	mV
TCV_{OS}	Input Offset Voltage Drift (Note 7, Note 9)	$V_{\text{CM}} = 2.1\text{V}$			7	$\mu\text{V}/^\circ\text{C}$
I_{B}	Input Bias Current (Note 10)	$V_{\text{CM}} = 2.1\text{V}$		13	23	μA
e_{ni}	Input Voltage Noise (Note 9)	$f > 10\text{ kHz}$, $R_G = 5\text{ k}\Omega$		120		$\text{nV}/\sqrt{\text{Hz}}$
$V_{\text{SENSE(MAX)}}$	Max Input Sense Voltage (Note 9)	$V_{\text{CM}} = 12\text{V}$, $R_G = 5\text{ k}\Omega$		600		mV
Gain A_V	Adjustable Gain Setting (Note 9)	$V_{\text{CM}} = 12\text{V}$	1		100	V/V
G_m	Transconductance	$V_{\text{CM}} = 2.1\text{V}$		200		$\mu\text{A}/\text{V}$
	Accuracy	$V_{\text{CM}} = 2.1\text{V}$	-2 -3.4		2 3.4	%
	Gm drift (Note 9)	-40°C to 125°C , $V_{\text{CM}} = 2.1\text{V}$			140	$\text{ppm}/^\circ\text{C}$
PSRR	Power Supply Rejection Ratio	$V_{\text{CM}} = 2.1\text{V}$, $2.7\text{V} < V^+ < 12\text{V}$	90			dB
CMRR	Common Mode Rejection Ratio	LMP8645HV $2.1\text{V} < V_{\text{CM}} < 76\text{V}$	95			dB
		LMP8645 $2.1\text{V} < V_{\text{CM}} < 42\text{V}$				
BW	-3 dB Bandwidth (Note 9)	$R_G = 10\text{ k}\Omega$, $C_G = 4\text{ pF}$, $V_{\text{SENSE}} = 400\text{ mV}$, $C_L = 30\text{ pF}$, $R_L = 1\text{M}\Omega$		860		kHz
		$R_G = 25\text{ k}\Omega$, $C_G = 4\text{ pF}$, $V_{\text{SENSE}} = 400\text{ mV}$, $C_L = 30\text{ pF}$, $R_L = 1\text{M}\Omega$		260		
		$R_G = 50\text{ k}\Omega$, $C_G = 4\text{ pF}$, $V_{\text{SENSE}} = 400\text{ mV}$, $C_L = 30\text{ pF}$, $R_L = 1\text{M}\Omega$		140		
SR	Slew Rate (Note 8, Note 9)	$V_{\text{CM}} = 5\text{V}$, $C_G = 4\text{ pF}$, V_{SENSE} from 100 mV to 500 mV, $C_L = 30\text{ pF}$, $R_L = 1\text{M}\Omega$		0.6		V/ μs
I_{S}	Supply Current	$V_{\text{CM}} = 2.1\text{V}$		555	765 920	μA
		$V_{\text{CM}} = -2\text{V}$		2200	2900 3110	
V_{OUT}	Maximum Output Voltage	$V_{\text{CM}} = 12\text{V}$, $R_G = 500\text{k}\Omega$	10.2			V
	Minimum Output Voltage	$V_{\text{CM}} = 2.1\text{V}$			24	mV
I_{OUT}	Output current (Note 9)	Sourcing, $V_{\text{OUT}} = 5.25\text{V}$, $R_G = 150\text{k}\Omega$		5		mA
		Sinking, $V_{\text{OUT}} = 5.25\text{V}$, $R_G = 150\text{k}\Omega$		5		
C_{LOAD}	Max Output Capacitance Load (Note 9)			30		pF

Note 1: Absolute Maximum Ratings indicate limits beyond which damage to the device may occur. Operating Ratings indicate conditions for which the device is intended to be functional, but specific performance is not guaranteed. For guaranteed specifications and the test conditions, see the Electrical Characteristics Tables.

Note 2: Human Body Model, applicable std. MIL-STD-883, Method 3015.7. Machine Model, applicable std. JESD22-A115-A (ESD MM std. of JEDEC) Field-Induced Charge-Device Model, applicable std. JESD22-C101-C (ESD FICDM std. of JEDEC).

Note 3: The maximum power dissipation must be derated at elevated temperatures and is dictated by $T_{\text{J(MAX)}}$, θ_{JA} , and the ambient temperature, T_A . The maximum allowable power dissipation $P_{\text{DMAX}} = (T_{\text{J(MAX)}} - T_A) / \theta_{\text{JA}}$ or the number given in Absolute Maximum Ratings, whichever is lower.

Note 4: Electrical Table values apply only for factory testing conditions at the temperature indicated. Factory testing conditions result in very limited self-heating of the device such that $T_{\text{J}} = T_A$. No guarantee of parametric performance is indicated in the electrical tables under conditions of internal self-heating where $T_{\text{J}} > T_A$.

Note 5: Typical values represent the most likely parametric norm at the time of characterization. Actual typical values may vary over time and will also depend on the application and configuration. The typical values are not tested and are not guaranteed on shipped production material.

Note 6: All limits are guaranteed by testing, design, or statistical analysis.

Note 7: Offset voltage temperature drift is determined by dividing the change in V_{OS} at the temperature extremes by the total temperature change.

Note 8: The number specified is the average of rising and falling slew rates and measured at 90% to 10%.

Note 9: This parameter is guaranteed by design and/or characterization and is not tested in production.

Note 10: Positive Bias Current corresponds to current flowing into the device.

Block Diagram

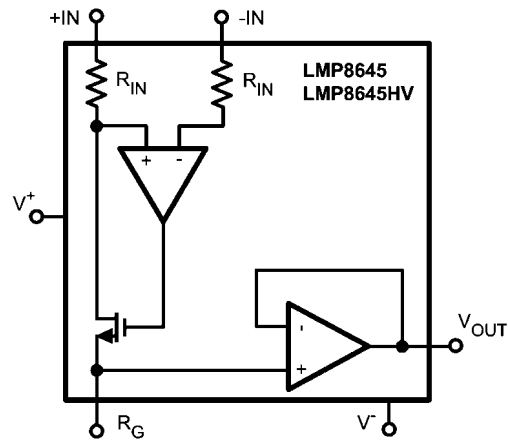

Connection Diagram

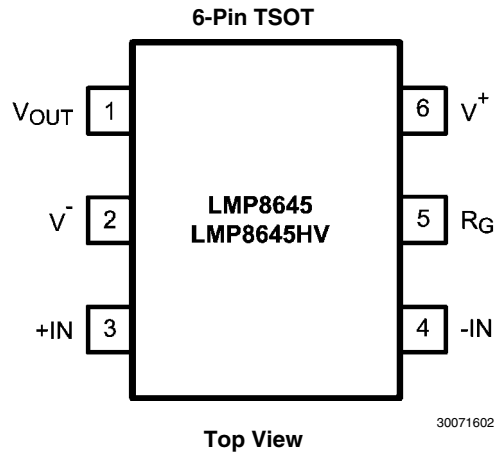

Pin Descriptions

Pin	Name	Description
1	V_{OUT}	Single Ended Output
2	V^{-}	Negative Supply Voltage
3	+IN	Positive Input
4	-IN	Negative Input
5	R_G	External Gain Resistor
6	V^{+}	Positive Supply Voltage

Ordering Information

Package	Part Number	Package Marking	Transport Media	NSC Drawing
6-Pin TSOT	LMP8645MK	AJ6A	1k Units Tape and Reel	MK06A
	LMP8645MKE		250 Units Tape and Reel	
	LMP8645MKX		3k Units Tape and Reel	
	LMP8645HVMK	AK6A	1k Units Tape and Reel	
	LMP8645HVMKE		250 Units Tape and Reel	
	LMP8645HVMKX		3k Units Tape and Reel	

Typical Performance Characteristics

(-IN), $R_L = 10\text{ M}\Omega$.

Unless otherwise specified: $T_A = 25^\circ\text{C}$, $V_S = V^+ - V^-$, $V_{\text{SENSE}} = +\text{IN} -$

Supply Current vs. Supply Voltage

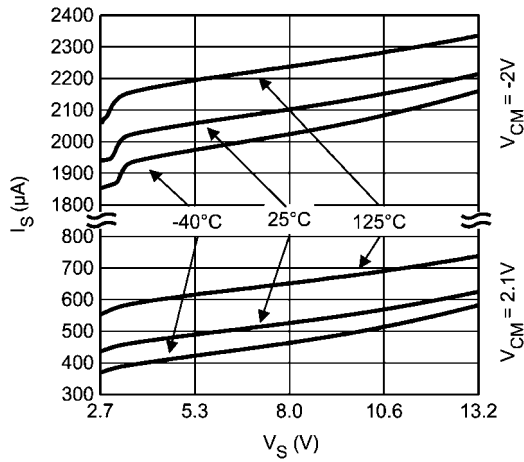

30071625

Supply current vs. V_{CM}

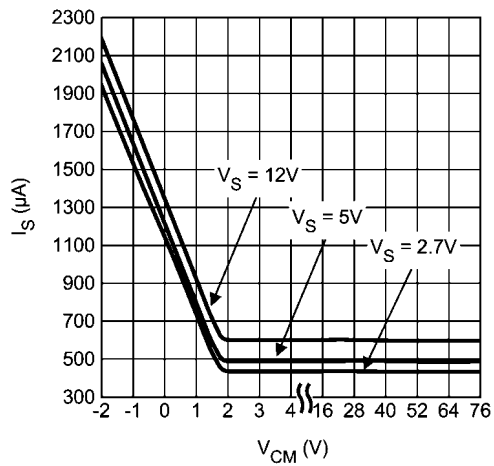

30071626

AC PSRR vs. Frequency

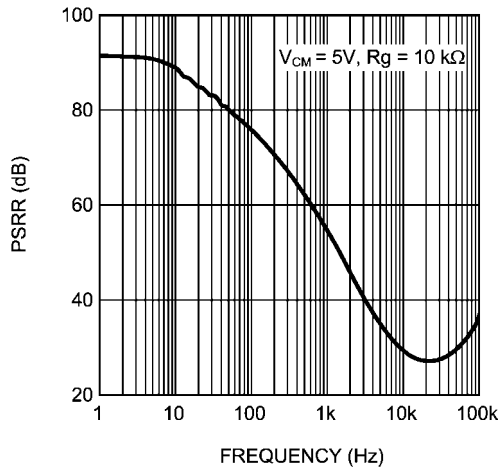

30071612

AC CMRR vs. Frequency

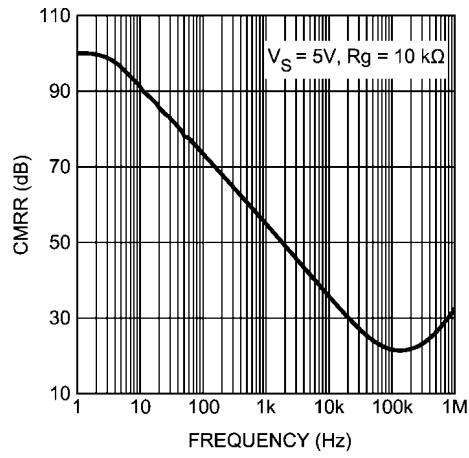

30071613

Gain vs. Frequency

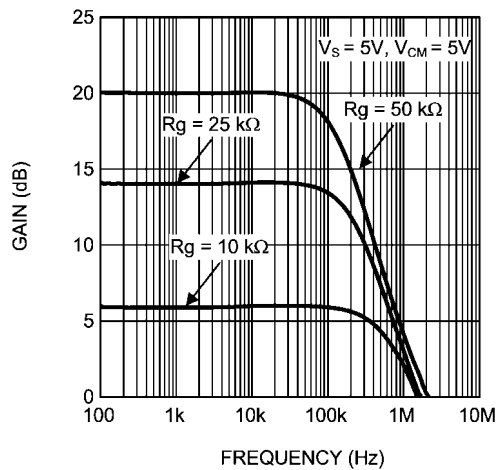

30071614

CMRR vs. V_{CM}

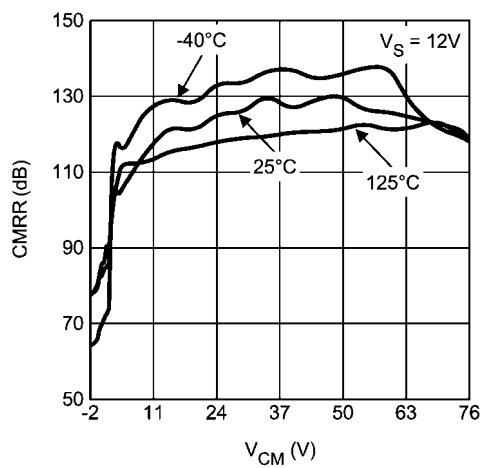

30071624

Output voltage vs. V_{SENSE}

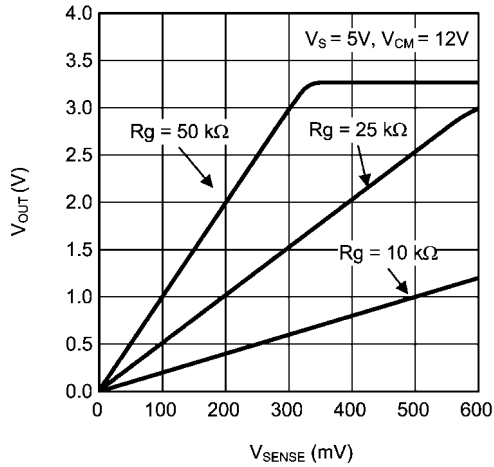

30071616

Output voltage vs. V_{SENSE} (ZOOM close to 0V)

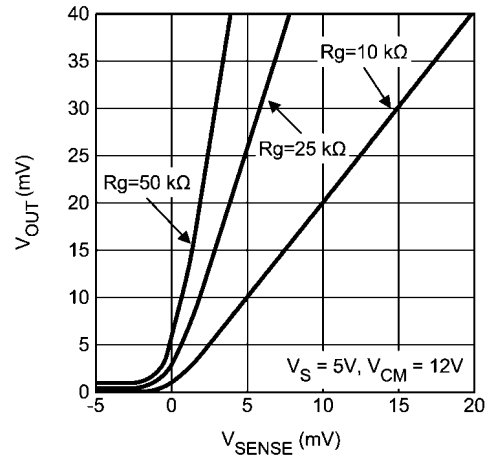

30071617

Large Step response

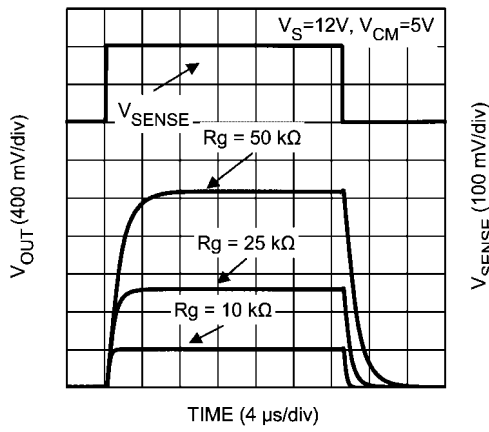

30071618

Small Step response

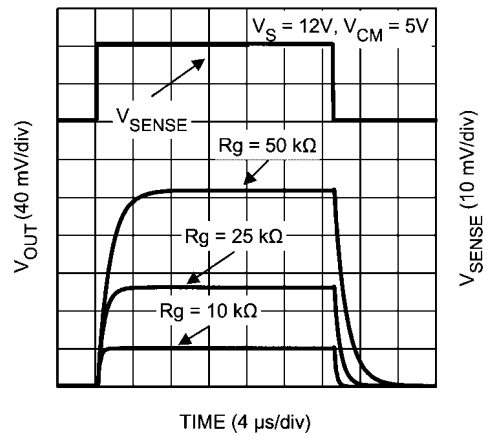

30071619

Settling time (rise)

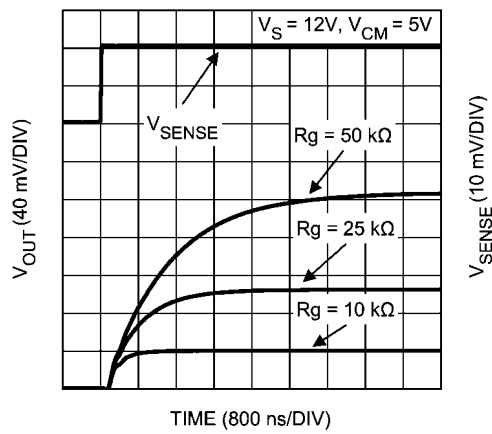

30071621

Settling time (fall)

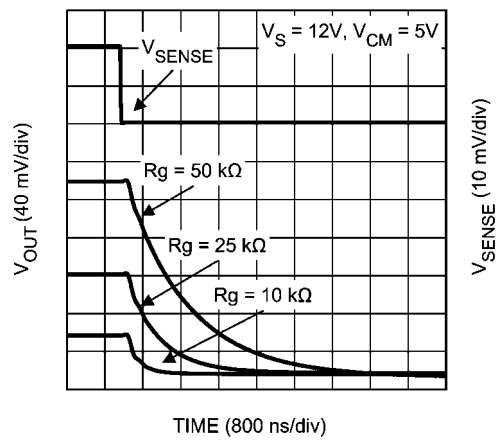

30071620

Common mode step response (rise)

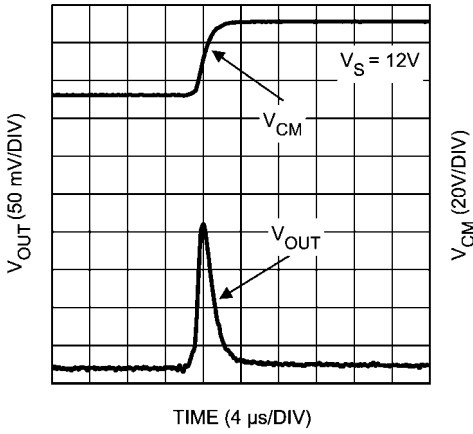

30071622

Common mode step response (fall)

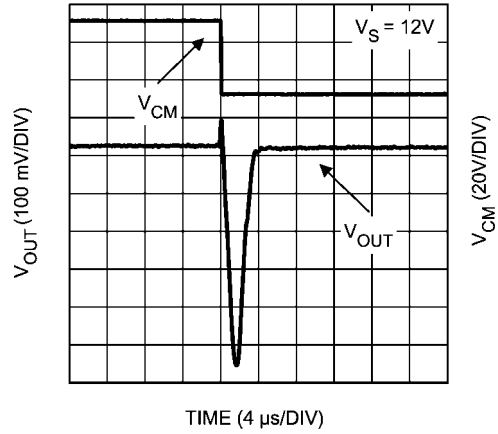

30071615

Application Information

GENERAL

The LMP8645 and LMP8645HV are single supply high side current sense amplifiers with variable gain selected through an external resistor and a common mode voltage Range of -2V to 42V or -2V to 76V depending on the grade.

The sense voltage is amplified by a user-selected gain and level shifted from the positive power supply to a ground-referred output.

THEORY OF OPERATION

As seen from the picture below, the current flowing through R_S develops a voltage drop equal to V_{SENSE} across R_S . The high impedance inputs of the amplifier doesn't conduct this current and the high open loop gain of the sense amplifier forces its non-inverting input to the same voltage as the inverting input. In this way the voltage drop across R_{IN} matches V_{SENSE} . A current proportional to I_S according to the following relation:

$$I_S' = V_{SENSE}/R_{IN} = R_S * I_S / R_{IN}, \text{ where } R_{IN} = 1/G_m$$

flows entirely in the external gain resistor developing a voltage drop equal to

$$V_G = I_S' * R_{GAIN} = (V_{SENSE}/R_{IN}) * R_{GAIN} = ((R_S * I_S)/R_{IN}) * R_{GAIN}$$

This voltage is buffered and showed at the output with a very low impedance allowing a very easy interface of the LMP8645 with other ICs (ADC, $\mu C...$).

$$V_{OUT} = (R_S * I_S) * G, \text{ where } G = R_{GAIN}/R_{IN}$$

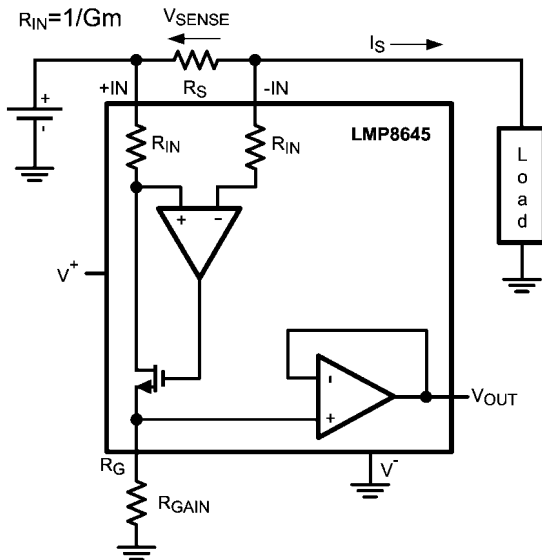

30071603

FIGURE 1. Current monitor

SELECTION OF THE SHUNT RESISTOR

The accuracy of the current measurement strictly depends on the value of the shunt resistor R_S . Its value depends on the application and it is a compromise between small-signal accuracy and maximum permissible voltage loss in the measurement section. High values of R_S provide better accuracy at lower currents by minimizing the effects of offset, while low values of R_S minimize voltage loss in the supply section. For most applications, best performance is obtained with an R_S

value that provides a full-scale shunt voltage Range of 100 mV to 200 mV.

SELECTION OF THE GAIN RESISTOR

In the LMP8645 and LMP8645HV the gain is selected through an external resistor connected to the R_G pin. Moreover the gain resistor R_{GAIN} determines the voltage of the output buffer which is related to the supply voltage and to the common mode voltage of the input signal. The gain resistor must be chosen such that the max output voltage does not exceed the LMP8645 max output voltage rating for a given common mode voltage.

The following equations explain how to select the gain resistor for various Range of the input common mode voltage.

$$\text{Range 1 } -2V < V_{CM} \leq 1.8V$$

The max voltage at the R_G pin is given by the following inequality $V_{RG} = V_{sense} * R_{GAIN} * G_m \leq \min(1.3V; V_{out_max})$ where V_{out_max} is the maximum allowable output voltage according to the Electrical Tables. All the gain resistors (R_{GAIN}) which respect the previous inequality are allowed. The graphical representation in Figure 2 helps in the selection; all the combinations (V_{SENSE} , R_{GAIN}) below the curve are allowed.

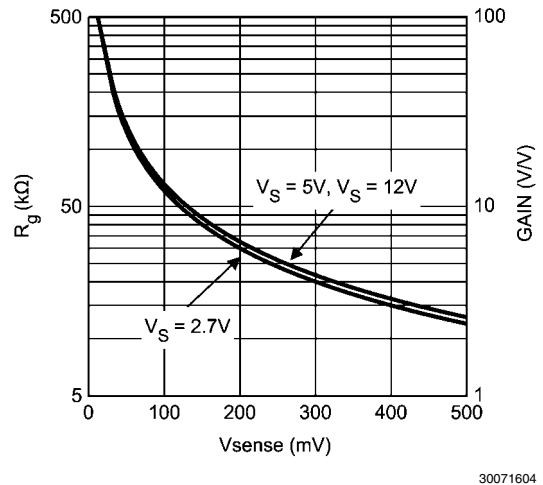

30071604

FIGURE 2. Allowed Gains for Range 1

As a consequence once selected the gain (R_{GAIN}) the V_{SENSE} Range is fixed too. For example if an application required a Gain of 10, R_G will be 50 k Ω and V_{SENSE} will be in the Range 10 mV to 100 mV.

$$\text{Range 2 } 1.8V < V_{CM} \leq V_S$$

In this Range the max voltage at the R_G pin is related to the common mode voltage and V_{SENSE} . So all the R_{GAIN} resistors which respect the following inequalities are allowed:

$$V_{R_G} \leq \min(V_{out_max}; (V_{CM} - V_{sense} - 250mV))$$

where

$$V_{RG} = V_{SENSE} * R_{GAIN} * G_m \text{ and } V_{out_max} \text{ is the maximum allowable output voltage according to the Electrical Tables.}$$

The graphical representation in Figure 3 helps in the selection; all the combinations (V_{SENSE} , R_{GAIN}) below the curves for given V_{CM} and supply voltage are allowed.

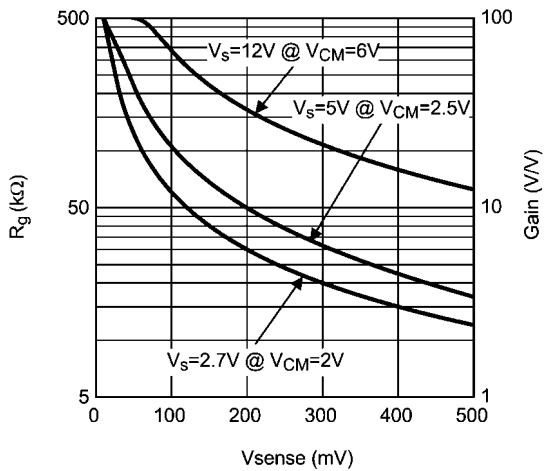

30071605

FIGURE 3. Allowed Gains for Range 2

Also in this Range once selected the R_{GAIN} (Gain) the V_{SENSE} Range is fixed too.

$$\text{Range 3 } V_{CM} \geq V_S$$

The max voltage at the R_G pin is V_{out_max} , it means that $V_{OUT} = V_{SENSE} * R_{GAIN}/R_{IN} \leq V_{out_max}$ where V_{out_max} is the maximum allowable output voltage according to the Electrical Tables. So all the R_{GAIN} resistors which respect the previous inequality are allowed. The graphical representation in helps in the selection; all the combinations (V_{SENSE} , R_{GAIN}) below the curves are allowed.

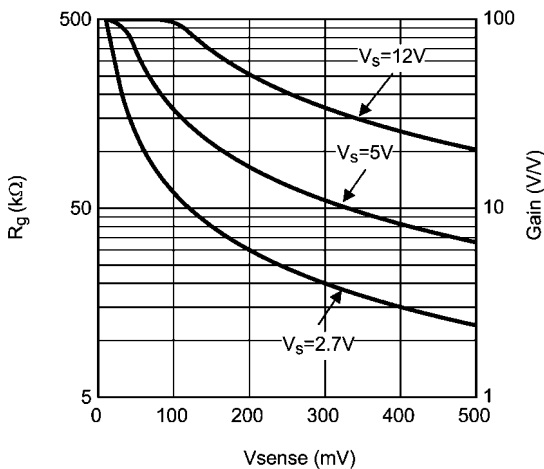

30071606

FIGURE 4. Allowed Gains for Range 3

Also in this Range once selected the R_{GAIN} (Gain) the V_{SENSE} Range is fixed too.

From the Ranges showed above a good way to maximize the output voltage swing of the LMP8645 is to select the max allowable R_{gain} according to the previous equations. For a

fixed supply voltage and V_{sense} as the common mode voltage increases, the max allowable R_{gain} increases too.

DESIGN GUIDELINE

Example 1

The LMP8645 is used to monitor the current supply of an active device (Refer to Figure 5). The LMP8645 is supplied at 5V the active device is supplied at 12V and the max current sunk is 1A. In this example the LMP8645 will work in all 3 Ranges: in Range 1 at the turning on of the active device, then in Range 3 passing through the Range 2. Since the purpose of the application is monitor the current of the active device in any operating state working condition (power on, normal operation, etc.), the gain resistor will be selected according to the Range 1, the Range which gives more constraints to the output dynamic voltage of the LMP8645.

At the startup of the monitored device the LMP8645 works at 0V common mode, it means that its max output is 1.3V (Range 1). In order to maximize the resolution the R_{sense} is calculated as max allowed V_{sense} (Refer to Figure 2) divided by max current (1A), so $R_{sense}=0.5\Omega$. Due to the output limitation the max allowed gain will be $2.6V/V$ so $R_{GAIN}=13k\Omega$. With this approach the current is monitored at any working condition but without using the entire output dynamic of the LMP8645. Alternatively if the monitored device doesn't sink 1A at any supply voltage, it is possible to design considering the max output voltage of the LMP8645 when operating in Range 3 ($V_{CM} \geq V_S$). Also in this case is possible to maximize the resolution using $R_{sense}=0.5\Omega$, and maximize the output dynamic with $R_{gain}=33k\Omega$. With this approach the max detectable current when V_{CM} is less than 1.8V is about 400mA, while for $V_{CM}=2.5V$ the max detectable current is 600mA (Refer to Figure 2) and for $V_{CM} \geq V_S$ is 1A.

The second approach maximizes the output dynamic but implies some knowledge on the monitored current.

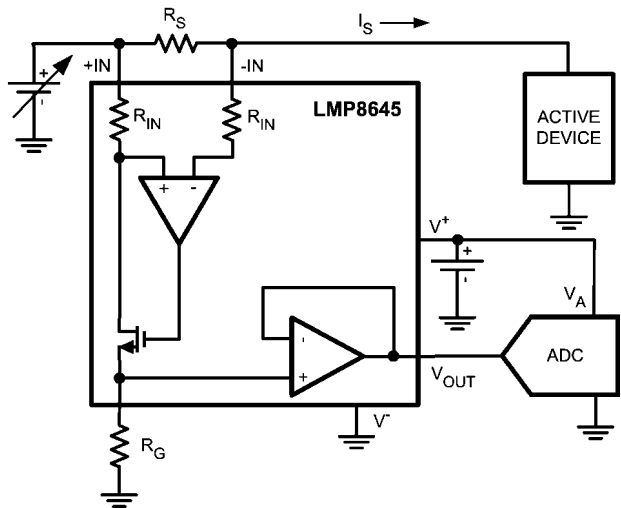

30071609

FIGURE 5. LMP8645 in current monitor application

Example 2

The LMP8645 is used to monitor the current in a high brightness LED application together with LM340x LED drivers. The LMP8645 is supplied at 3.3V and the max voltage at LED's string is 30V, the LED brightness is controlled with the dimming (MOSFET in parallel to the LED). The approach of the high current sense is used especially in automotive application where the cathode of the LED needs to be directly connected to the chassis of the car (Ground of the system). Even though LMP8645 will work in all 3 Ranges as in the previous example, R_{GAIN} will be calculated according to Range 3 because the purpose is regulating the current in the LEDs when the external MOSFET is OFF (LMP8645 at high V_{CM}). Even if this approach makes the LMP8645 able to sense high peak current only in Range 3 where the dynamic output is higher than Range 1 the current resolution is maximized. At each switch ON/OFF of the MOSFET the LMP8645 goes from Range 1 (MOSFET ON, string of LED OFF), to Range 3 (MOSFET OFF, string of LED ON) passing through Range 2 (MOSFET OFF, string of LED OFF). Since the purpose of the application is to sense the current with high precision when the LED string is ON, the R_{GAIN} will be calculated according to the Range 3.

To summarize, the R_{GAIN} will be calculated according to the range of operation in which the application will mainly work. Once selected the range, will be taken in account the more stringent constraint

DRIVING ADC

The input stage of an Analog to Digital converter can be modeled with a resistor and a capacitance versus ground. So if the voltage source doesn't have a low impedance an error in the amplitude's measurement will occur. In this Range a buffer is needed to drive the ADC. The LMP8645 has an internal output buffer able to drive a capacitance load up to 30 pF or the input stage of an ADC. If required an external low pass RC filter can be added at the output of the LMP8645 to reduce the noise and the bandwidth of the current sense. Any other filter solution which implies a capacitance connected to the R_G pin is not suggested due to the high impedance of that pin.

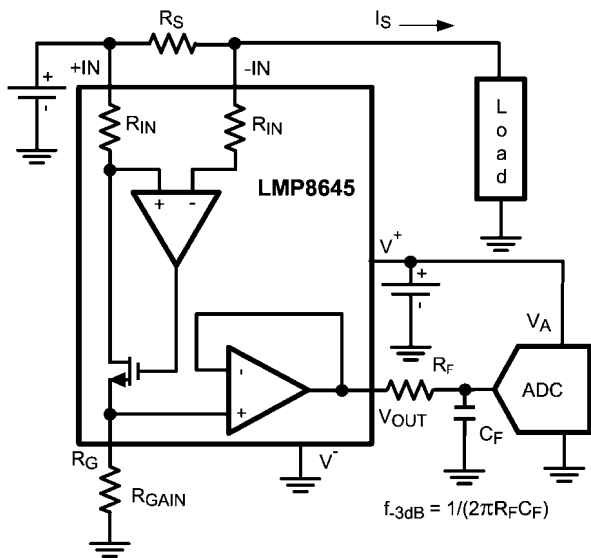

FIGURE 6. LMP8645 to ADC interface

SENSING CURRENT IN LED DRIVER APPLICATIONS

The LMP8645 is the right choice in the applications which requires high side current sense, such as High Brightness LED for automotive where the LED's cathode has to be connected to the Range (ground) of the car. In this Range the classical low side current sense with a shunt resistor connected between the LED's cathode and the Range doesn't guarantee the ground connection. In Figure 7, the LMP8645 monitors the current for the LM3406 a constant current buck regulator. The LMP8645 is supplied by the internal LDO of the LM3406 through the pin VCC, the current which flows in the LED is programmed according the following formula: $I_F = V_{CS} / (R_S * Gain)$, where $Gain = R_{GAIN} * G_m$ and $V_{CS} = 200$ mV. In this application the current which flows in the HB LED is in the Range between 350 mA and 1A, so in order to reduce the power dissipation on the shunt resistor and have a good accuracy, the R_S should be in the Range between 50 mΩ and 200 mΩ. In the table below two examples are analyzed.

	$I_F=350mA$	$I_F=1A$
R_{GAIN}	40kΩ	36kΩ
R_S	77mΩ	27mΩ
Dissipated Power	9.5mW	27mW
Total Accuracy	≈5%	≈5%

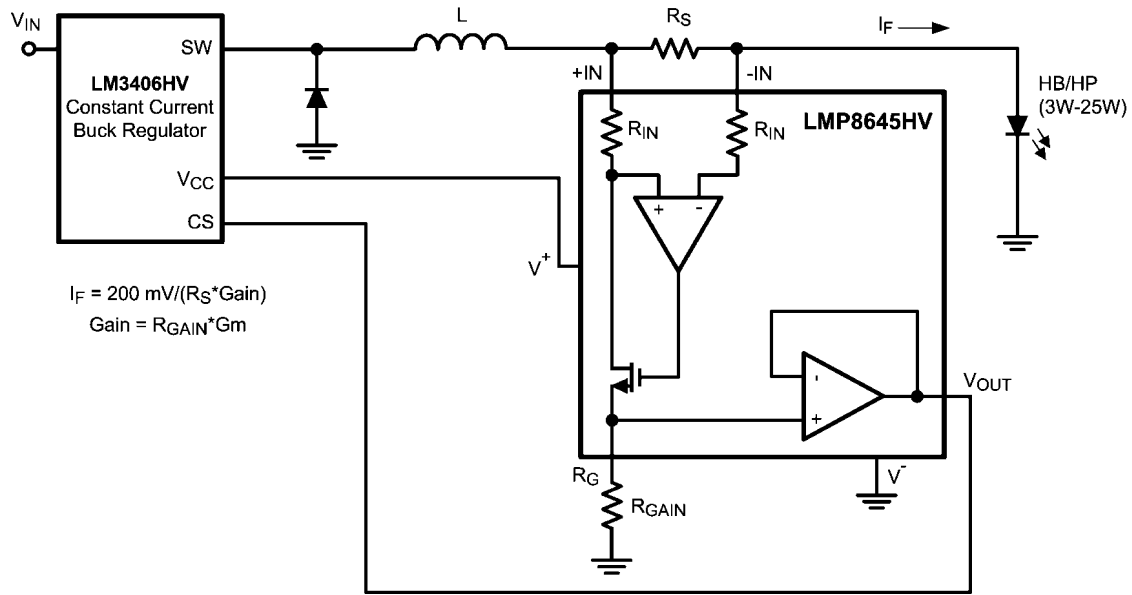
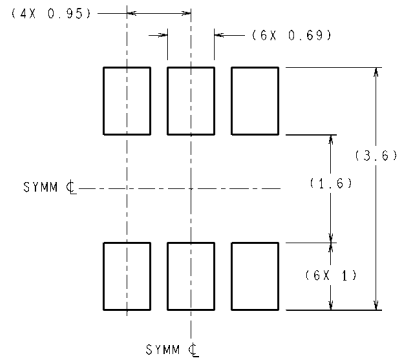
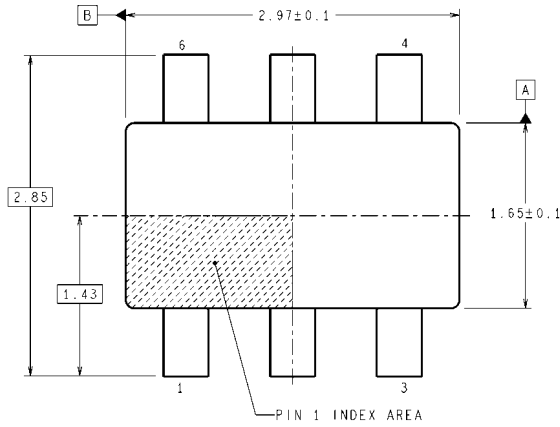
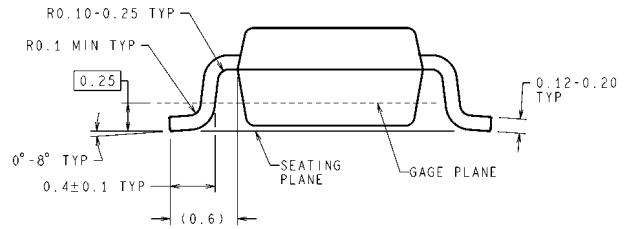
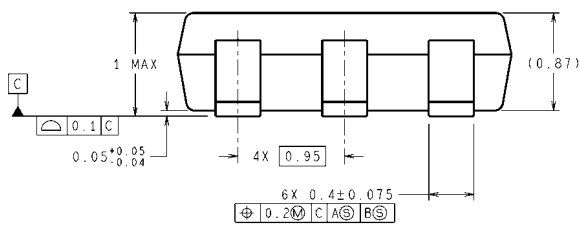

FIGURE 7. High Side Current Sensing in Driving HP/HB LED

Physical Dimensions inches (millimeters) unless otherwise noted



RECOMMENDED LAND PATTERN



DIMENSIONS ARE IN MILLIMETERS
TSOT-6
NS Package Number MK06A

MK06A (Rev E)

Notes

LMP8645/LMP8645HV

Notes

For more National Semiconductor product information and proven design tools, visit the following Web sites at:
www.national.com

Products		Design Support	
Amplifiers	www.national.com/amplifiers	WEBENCH® Tools	www.national.com/webench
Audio	www.national.com/audio	App Notes	www.national.com/appnotes
Clock and Timing	www.national.com/timing	Reference Designs	www.national.com/refdesigns
Data Converters	www.national.com/adc	Samples	www.national.com/samples
Interface	www.national.com/interface	Eval Boards	www.national.com/evalboards
LVDS	www.national.com/lvds	Packaging	www.national.com/packaging
Power Management	www.national.com/power	Green Compliance	www.national.com/quality/green
Switching Regulators	www.national.com/switchers	Distributors	www.national.com/contacts
LDOs	www.national.com/lido	Quality and Reliability	www.national.com/quality
LED Lighting	www.national.com/led	Feedback/Support	www.national.com/feedback
Voltage References	www.national.com/vref	Design Made Easy	www.national.com/easy
PowerWise® Solutions	www.national.com/powerwise	Applications & Markets	www.national.com/solutions
Serial Digital Interface (SDI)	www.national.com/sdi	Mil/Aero	www.national.com/milaero
Temperature Sensors	www.national.com/tempensors	SolarMagic™	www.national.com/solarmagic
PLL/VCO	www.national.com/wireless	PowerWise® Design University	www.national.com/training

THE CONTENTS OF THIS DOCUMENT ARE PROVIDED IN CONNECTION WITH NATIONAL SEMICONDUCTOR CORPORATION ("NATIONAL") PRODUCTS. NATIONAL MAKES NO REPRESENTATIONS OR WARRANTIES WITH RESPECT TO THE ACCURACY OR COMPLETENESS OF THE CONTENTS OF THIS PUBLICATION AND RESERVES THE RIGHT TO MAKE CHANGES TO SPECIFICATIONS AND PRODUCT DESCRIPTIONS AT ANY TIME WITHOUT NOTICE. NO LICENSE, WHETHER EXPRESS, IMPLIED, ARISING BY ESTOPPEL OR OTHERWISE, TO ANY INTELLECTUAL PROPERTY RIGHTS IS GRANTED BY THIS DOCUMENT.

TESTING AND OTHER QUALITY CONTROLS ARE USED TO THE EXTENT NATIONAL DEEMS NECESSARY TO SUPPORT NATIONAL'S PRODUCT WARRANTY. EXCEPT WHERE MANDATED BY GOVERNMENT REQUIREMENTS, TESTING OF ALL PARAMETERS OF EACH PRODUCT IS NOT NECESSARILY PERFORMED. NATIONAL ASSUMES NO LIABILITY FOR APPLICATIONS ASSISTANCE OR BUYER PRODUCT DESIGN. BUYERS ARE RESPONSIBLE FOR THEIR PRODUCTS AND APPLICATIONS USING NATIONAL COMPONENTS. PRIOR TO USING OR DISTRIBUTING ANY PRODUCTS THAT INCLUDE NATIONAL COMPONENTS, BUYERS SHOULD PROVIDE ADEQUATE DESIGN, TESTING AND OPERATING SAFEGUARDS.

EXCEPT AS PROVIDED IN NATIONAL'S TERMS AND CONDITIONS OF SALE FOR SUCH PRODUCTS, NATIONAL ASSUMES NO LIABILITY WHATSOEVER, AND NATIONAL DISCLAIMS ANY EXPRESS OR IMPLIED WARRANTY RELATING TO THE SALE AND/OR USE OF NATIONAL PRODUCTS INCLUDING LIABILITY OR WARRANTIES RELATING TO FITNESS FOR A PARTICULAR PURPOSE, MERCHANTABILITY, OR INFRINGEMENT OF ANY PATENT, COPYRIGHT OR OTHER INTELLECTUAL PROPERTY RIGHT.

LIFE SUPPORT POLICY

NATIONAL'S PRODUCTS ARE NOT AUTHORIZED FOR USE AS CRITICAL COMPONENTS IN LIFE SUPPORT DEVICES OR SYSTEMS WITHOUT THE EXPRESS PRIOR WRITTEN APPROVAL OF THE CHIEF EXECUTIVE OFFICER AND GENERAL COUNSEL OF NATIONAL SEMICONDUCTOR CORPORATION. As used herein:

Life support devices or systems are devices which (a) are intended for surgical implant into the body, or (b) support or sustain life and whose failure to perform when properly used in accordance with instructions for use provided in the labeling can be reasonably expected to result in a significant injury to the user. A critical component is any component in a life support device or system whose failure to perform can be reasonably expected to cause the failure of the life support device or system or to affect its safety or effectiveness.

National Semiconductor and the National Semiconductor logo are registered trademarks of National Semiconductor Corporation. All other brand or product names may be trademarks or registered trademarks of their respective holders.

Copyright© 2011 National Semiconductor Corporation

For the most current product information visit us at www.national.com



National Semiconductor Americas Technical Support Center
 Email: support@nsc.com
 Tel: 1-800-272-9959

National Semiconductor Europe Technical Support Center
 Email: europe.support@nsc.com

National Semiconductor Asia Pacific Technical Support Center
 Email: ap.support@nsc.com

National Semiconductor Japan Technical Support Center
 Email: jpn.feedback@nsc.com