

Power Operational Amplifier

FEATURES

- **LOW COST, ECONOMY MODEL** — PA01
- **HIGH OUTPUT CURRENT** — Up to $\pm 5A$ PEAK
- **EXCELLENT LINEARITY** — PA01
- **HIGH SUPPLY VOLTAGE** — Up to $\pm 30V$
- **ISOLATED CASE** — 300V



APPLICATIONS

- **MOTOR, VALVE AND ACTUATOR CONTROL**
- **MAGNETIC DEFLECTION CIRCUITS UP TO 4A**
- **POWER TRANSDUCERS UP TO 20kHz**
- **TEMPERATURE CONTROL UP TO 180W**
- **PROGRAMMABLE POWER SUPPLIES UP TO 48V**
- **AUDIO AMPLIFIERS UP TO 50W RMS**

**8-PIN TO-3
PACKAGE STYLE CE**

DESCRIPTION

The PA01 and PA73 are high voltage, high output current operational amplifiers designed to drive resistive, inductive and capacitive loads. For optimum linearity, the PA01 has a class A/B output stage. The PA73 has a simple class C output stage (see Note 1) to reduce cost for motor control and other applications where crossover distortion is not critical and to provide interchangeability with type 3573 amplifiers. The safe operating area (SOA) can be observed for all operating conditions by selection of user programmable current limit resistors. These amplifiers are internally compensated for all gain settings. For continuous operation under load, a heatsink of proper rating is recommended.

This hybrid integrated circuit utilizes thick film (cermet) resistors, ceramic capacitors and semiconductor chips to maximize reliability, minimize size and give top performance. Ultrasonically bonded aluminum wires provide reliable interconnections at all operating temperatures. The 8-pin TO-3 package is hermetically sealed and electrically isolated. The use of compressible thermal washers and/or improper mounting torque will void the product warranty. Please see "General Operating Considerations".

EXTERNAL CONNECTIONS

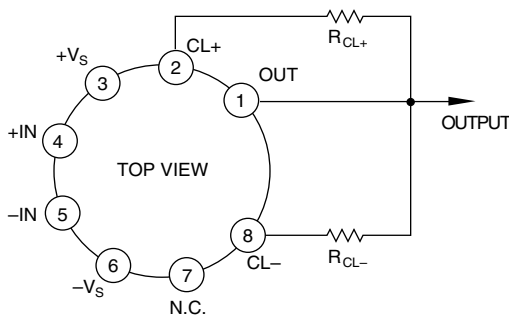

TYPICAL APPLICATION

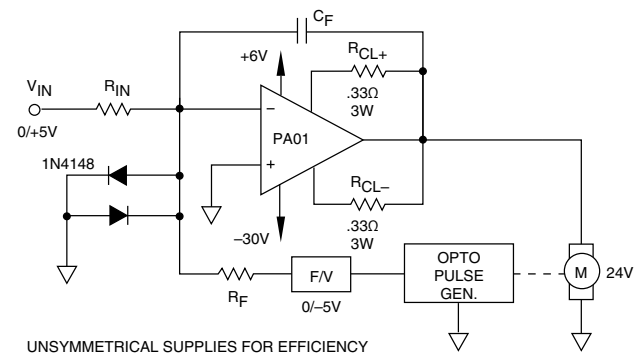

UNSYMMETRICAL SUPPLIES FOR EFFICIENCY

Unidirectional Optical Speed Control

The pulse output of a non-contact optical sensor drives a voltage-to-frequency converter which generates feedback for the op amp. With the loop closed in this manner, the op amp corrects for any variations in the speed due to changing load. Because of operation in only one direction, an unsymmetrical supply is used to maximize efficiency of both power op amp and power supply. High speed diodes at the input protect the op amp from commutator noise which may be generated by the motor.

EQUIVALENT SCHEMATIC

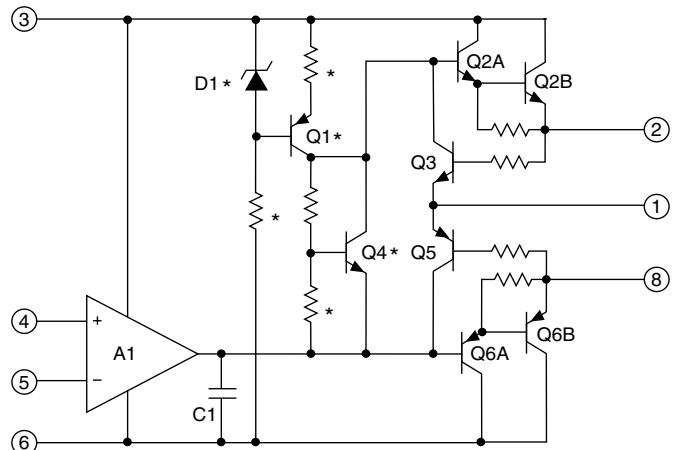

NOTE 1: * Indicates not used in PA73. Open base of Q2A connected to output of A1.

ABSOLUTE MAXIMUM RATINGS

	PA01	PA73
SUPPLY VOLTAGE, +V _S to -V _S	60V	68V
OUTPUT CURRENT, within SOA	5A	5A
POWER DISSIPATION, internal	67W	67W
INPUT VOLTAGE, differential	±37V	±37V
INPUT VOLTAGE, common-mode	±V _S	±V _S
TEMPERATURE, junction ¹	200°C	200°C
TEMPERATURE, pin solder -10s	300°C	300°C
TEMPERATURE RANGE, storage	-65 to +150°C	-65 to +150°C
OPERATING TEMPERATURE RANGE, case	-25 to +85°C	-25 to +85°C

SPECIFICATIONS

PARAMETER	TEST CONDITIONS ²	PA01			PA73			UNITS
		MIN	TYP	MAX	MIN	TYP	MAX	
INPUT								
OFFSET VOLTAGE, initial	T _C = 25°C		±5	±12	*		±10	mV
OFFSET VOLTAGE, vs. temperature	Full temperature range		±10	±65	*		*	μV/°C
OFFSET VOLTAGE, vs. supply	T _C = 25°C		±35		*		±200	μV/V
OFFSET VOLTAGE, vs. power	T _C = 25°C		±20		*			μV/W
BIAS CURRENT, initial	T _C = 25°C		±15	±50	*		±40	nA
BIAS CURRENT, vs. temperature	Full temperature range		±0.05	±.4	*		*	nA/°C
BIAS CURRENT, vs. supply	T _C = 25°C		±.02		*			nA/V
OFFSET CURRENT, initial	T _C = 25°C		±12	±30	*		*	nA
OFFSET CURRENT, vs. temperature	Full temperature range		±0.05		*			nA/°C
INPUT IMPEDANCE, common-mode	T _C = 25°C		200		*			MΩ
INPUT IMPEDANCE, differential	T _C = 25°C		10		*			MΩ
INPUT CAPACITANCE	T _C = 25°C		3		*			pF
COMMON MODE VOLTAGE RANGE ³	Full temperature range	±V _S -6	±V _S -3		*	*		V
COMMON MODE REJECTION, DC ³	T _C = 25°C, V _{CM} = V _S -6V	70	110		*	*		dB
GAIN								
OPEN LOOP GAIN at 10Hz	Full temp. range, full load	91	113		*	*		dB
GAIN BANDWIDTH PRODUCT @ 1MHz	T _C = 25°C, full load		1		*	*		MHz
POWER BANDWIDTH	T _C = 25°C, I _O = 4A, V _O = 40V _{PP}	15	23		*	*		kHz
PHASE MARGIN	Full temperature range		45		*	*		°
OUTPUT								
VOLTAGE SWING ³	T _C = 25°C, I _O = 5A	±V _S -10	±V _S -5		±V _S -8	*		V
VOLTAGE SWING ³	Full temp. range, I _O = 2A	±V _S -6	±V _S -5		*	*		V
VOLTAGE SWING ³	Full temp. range, I _O = 46mA	±V _S -5			*			V
CURRENT, peak	T _C = 25°C	±5			*			A
SETTLING TIME to .1%	T _C = 25°C, 2V step		2		*	*		μs
SLEW RATE	T _C = 25°C, R _L = 2.5Ω	1.0	2.6		*	*		V/μs
CAPACITIVE LOAD, unity gain	Full temperature range			1			*	nF
CAPACITIVE LOAD, gain > 4	Full temperature range			SOA			*	
POWER SUPPLY								
VOLTAGE	Full temperature range	±10	±28	±28	*	*	±30	V
CURRENT, quiescent	T _C = 25°C		20	50		2.6	5	mA
THERMAL								
RESISTANCE, AC, junction to case ⁴	F > 60Hz		1.9	2.1		*	*	°C/W
RESISTANCE, DC, junction to case	F < 60Hz		2.4	2.6		*	*	°C/W
RESISTANCE, junction to air			30			*	*	°C/W
TEMPERATURE RANGE, case	Meets full range specifications	-25	25	+85	*	*	*	°C

- NOTES: * The specification of PA73 is identical to the specification for PA01 in applicable column to the left.
1. Long term operation at the maximum junction temperature will result in reduced product life. Derate internal power dissipation to achieve high MTTF.
 2. The power supply voltage specified under the TYP rating applies unless otherwise noted as a test condition.
 3. +V_S and -V_S denote the positive and negative supply rail respectively. Total V_S is measured from +V_S to -V_S.
 4. Rating applies if the output current alternates between both output transistors at a rate faster than 60Hz.

CAUTION The internal substrate contains beryllia (BeO). Do not break the seal. If accidentally broken, do not crush, machine, or subject to temperatures in excess of 850°C to avoid generating toxic fumes.

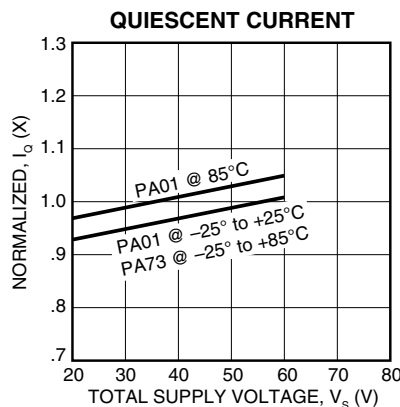
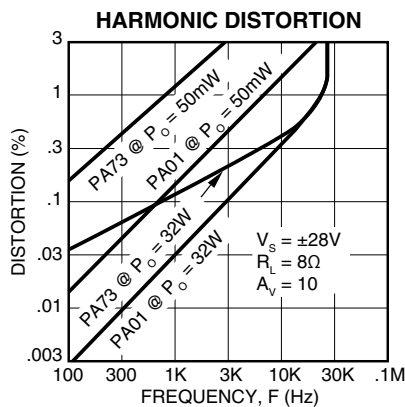
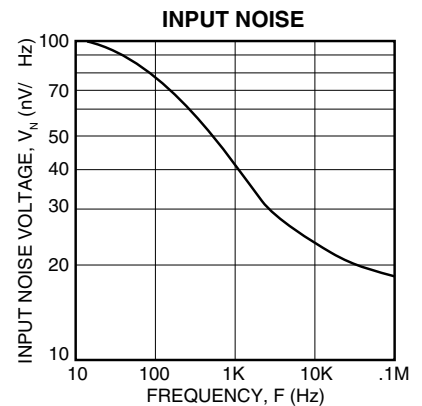
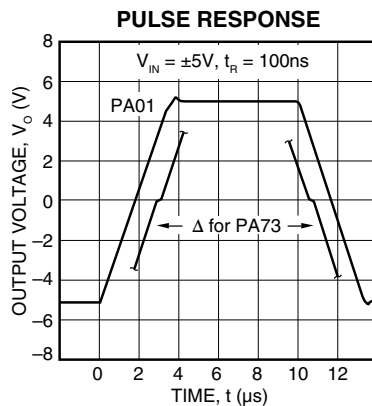
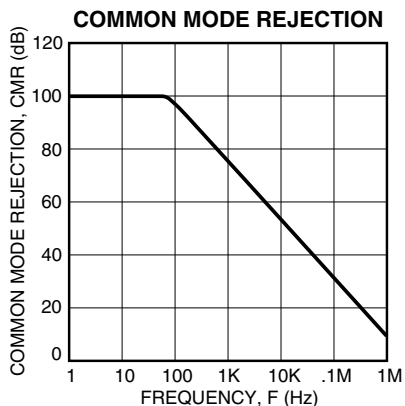
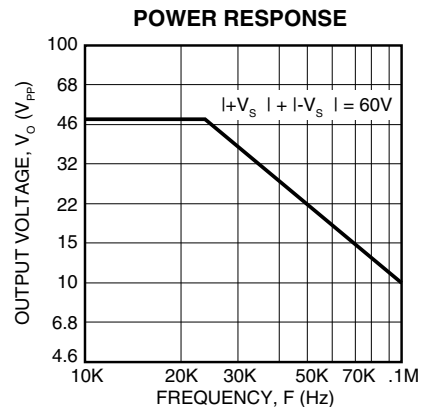
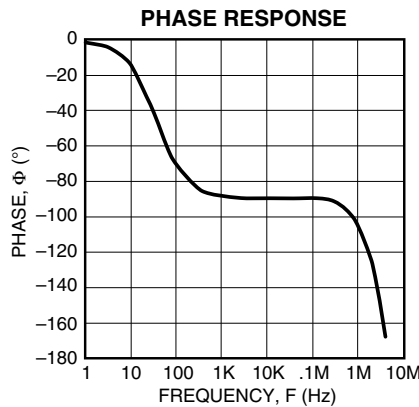
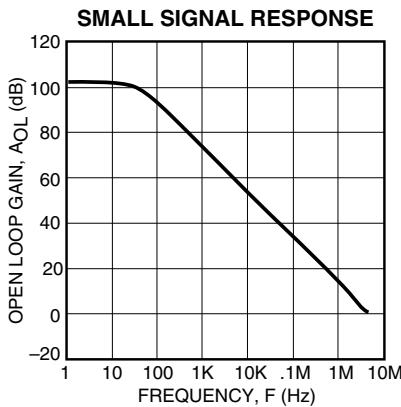
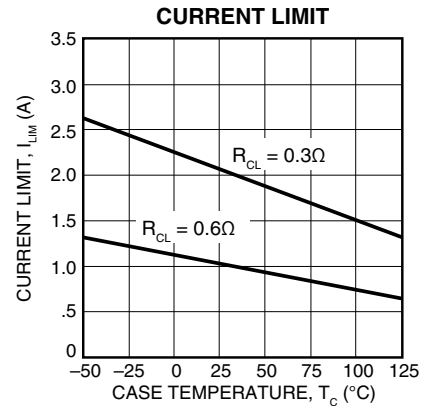
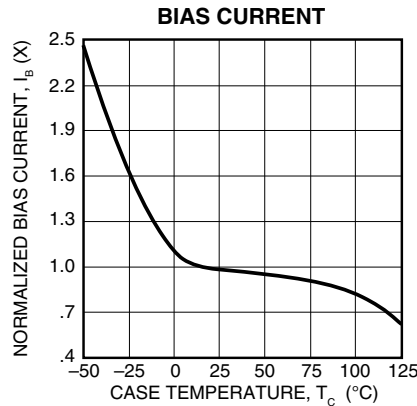
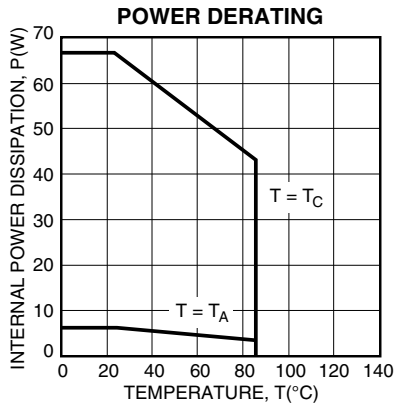

GENERAL

Please read Application Note 1 "General Operating Considerations" which covers stability, supplies, heat sinking, mounting, current limit, SOA interpretation, and specification interpretation. Visit www.cirrus.com for design tools that help automate tasks such as calculations for stability, internal power dissipation, current limit and heat sink selection. The "Application Notes" and "Technical Seminar" sections contain a wealth of information on specific types of applications. Package outlines, heat sinks, mounting hardware and other accessories are located in the "Packages and Accessories" section. Evaluation Kits are available for most Apex Precision Power product models, consult the "Evaluation Kit" section for details. For the most current version of all Apex Precision Power product data sheets, visit www.cirrus.com.

SAFE OPERATING AREA (SOA)

The output stage of most power amplifiers has three distinct limitations:

1. The current handling capability of the transistor geometry and the wire bonds.
2. The second breakdown effect which occurs whenever the simultaneous collector current and collector-emitter voltage exceeds specified limits.
3. The junction temperature of the output transistors.

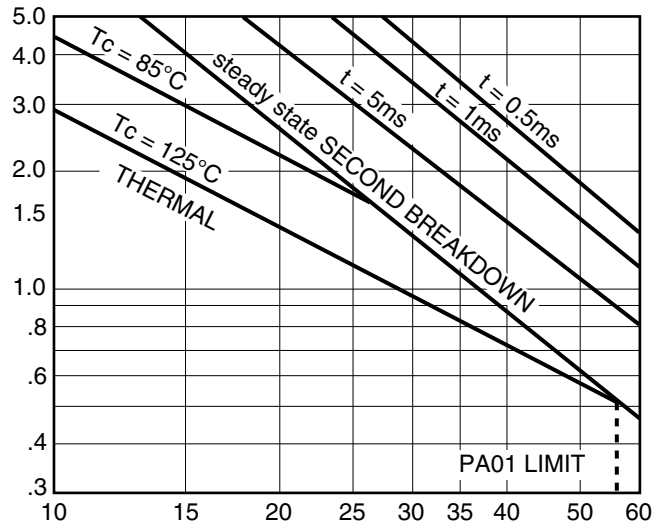

The SOA curves combine the effect of these limits. For a given application, the direction and magnitude of the output current should be calculated or measured and checked against the SOA curves. This is simple for resistive loads but more complex for reactive and EMF generating loads.

1. For sine wave outputs, use Power Design¹ to plot a load line. Make sure the load line does not cross the 0.5ms limit and that excursions beyond any other second breakdown line do not exceed the time label, and have a duty cycle of no more than 10%.

For other waveform outputs, manual load line plotting is recommended. Applications Note 22, SOA AND LOAD LINES, will be helpful. A Spice type analysis can be very useful in that a hardware setup often calls for instruments or amplifiers with wide common mode rejection ranges.

2. EMF generating or reactive load and short circuits to the supply rail or shorts to common are safe if the current limits are set as follows at $T_c = 85^\circ\text{C}$.

$\pm V_s$	SHORT TO $\pm V_s$ C, L, OR EMF LOAD	SHORT TO COMMON
34V	.58A	1.1A
30V	.46A	1.4A
25V	.61A	1.7A
20V	.86A	2.1A
15V	1.3A	2.9A

3. The output stage is protected against occasional transient flyback. However, for protection against sustained, high energy flyback, external fast-recovery diodes should be used.

CURRENT LIMIT

Proper operation requires the use of two current limit resistors, connected as shown, in the external connection diagram. The minimum value for R_{CL} is 0.12 ohm; however, for optimum reliability it should be set as high as possible. Refer to the "General Operating Considerations" section of the handbook for current limit adjust details.

¹ Note 1. Power Design is a self-extracting Excel spreadsheet available free from www.cirrus.com

CONTACTING CIRRUS LOGIC SUPPORT

For all Apex Precision Power product questions and inquiries, call toll free 800-546-2739 in North America.

For inquiries via email, please contact apex.support@cirrus.com.

International customers can also request support by contacting their local Cirrus Logic Sales Representative.

To find the one nearest to you, go to www.cirrus.com

IMPORTANT NOTICE

Cirrus Logic, Inc. and its subsidiaries ("Cirrus") believe that the information contained in this document is accurate and reliable. However, the information is subject to change without notice and is provided "AS IS" without warranty of any kind (express or implied). Customers are advised to obtain the latest version of relevant information to verify, before placing orders, that information being relied on is current and complete. All products are sold subject to the terms and conditions of sale supplied at the time of order acknowledgment, including those pertaining to warranty, indemnification, and limitation of liability. No responsibility is assumed by Cirrus for the use of this information, including use of this information as the basis for manufacture or sale of any items, or for infringement of patents or other rights of third parties. This document is the property of Cirrus and by furnishing this information, Cirrus grants no license, express or implied under any patents, mask work rights, copyrights, trademarks, trade secrets or other intellectual property rights. Cirrus owns the copyrights associated with the information contained herein and gives consent for copies to be made of the information only for use within your organization with respect to Cirrus integrated circuits or other products of Cirrus. This consent does not extend to other copying such as copying for general distribution, advertising or promotional purposes, or for creating any work for resale.

CERTAIN APPLICATIONS USING SEMICONDUCTOR PRODUCTS MAY INVOLVE POTENTIAL RISKS OF DEATH, PERSONAL INJURY, OR SEVERE PROPERTY OR ENVIRONMENTAL DAMAGE ("CRITICAL APPLICATIONS"). CIRRUS PRODUCTS ARE NOT DESIGNED, AUTHORIZED OR WARRANTED TO BE SUITABLE FOR USE IN PRODUCTS SURGICALLY IMPLANTED INTO THE BODY, AUTOMOTIVE SAFETY OR SECURITY DEVICES, LIFE SUPPORT PRODUCTS OR OTHER CRITICAL APPLICATIONS. INCLUSION OF CIRRUS PRODUCTS IN SUCH APPLICATIONS IS UNDERSTOOD TO BE FULLY AT THE CUSTOMER'S RISK AND CIRRUS DISCLAIMS AND MAKES NO WARRANTY, EXPRESS, STATUTORY OR IMPLIED, INCLUDING THE IMPLIED WARRANTIES OF MERCHANTABILITY AND FITNESS FOR PARTICULAR PURPOSE, WITH REGARD TO ANY CIRRUS PRODUCT THAT IS USED IN SUCH A MANNER. IF THE CUSTOMER OR CUSTOMER'S CUSTOMER USES OR PERMITS THE USE OF CIRRUS PRODUCTS IN CRITICAL APPLICATIONS, CUSTOMER AGREES, BY SUCH USE, TO FULLY INDEMNIFY CIRRUS, ITS OFFICERS, DIRECTORS, EMPLOYEES, DISTRIBUTORS AND OTHER AGENTS FROM ANY AND ALL LIABILITY, INCLUDING ATTORNEYS' FEES AND COSTS, THAT MAY RESULT FROM OR ARISE IN CONNECTION WITH THESE USES.

Cirrus Logic, Cirrus, and the Cirrus Logic logo designs, Apex Precision Power, Apex and the Apex Precision Power logo designs are trademarks of Cirrus Logic, Inc. All other brand and product names in this document may be trademarks or service marks of their respective owners.
