

60V Common Mode, Fixed Gain, Bidirectional Precision Current Sensing Amplifier

General Description

The LMP8602 and LMP8603 are fixed gain precision amplifiers. The parts will amplify and filter small differential signals in the presence of high common mode voltages. The input common mode voltage range is -22V to $+60\text{V}$ when operating from a single 5V supply. With a 3.3V supply, the input common mode voltage range is from -4V to $+27\text{V}$. The LMP8602 and LMP8603 are members of the Linear Monolithic Precision (LMP®) family and are ideal parts for unidirectional and bidirectional current sensing applications. All parameter values of the parts that are shown in the tables are 100% tested and all bold values are also 100% tested over temperature.

The parts have a precise gain of 50x for the LMP8602 and 100x for the LMP8603, which are adequate in most targeted applications to drive an ADC to its full scale value. The fixed gain is achieved in two separate stages, a preamplifier with a gain of 10x and an output stage buffer amplifier with a gain of 5x for the LMP8602 and 10x for the LMP8603. The connection between the two stages of the signal path is brought out on two pins to enable the possibility to create an additional filter network around the output buffer amplifier. These pins can also be used for alternative configurations with different gain as described in the applications section.

The mid-rail offset adjustment pin enables the user to use these devices for bidirectional single supply voltage current sensing. The output signal is bidirectional and mid-rail referenced when this pin is connected to the positive supply rail. With the offset pin connected to ground, the output signal is unidirectional and ground-referenced.

The LMP8602 and LMP8603 are available in a 8-Pin SOIC package and in a 8-Pin MSOP package.

The LMP8602Q and LMP8603Q incorporate enhanced manufacturing and support processes for the automotive market, including defect detection methodologies. Reliability qualification is compliant with the requirements and temperature grades defined in the AEC Q100 standard.

Features

Unless otherwise noted, typical values at $T_A = 25^\circ\text{C}$, $V_S = 5.0\text{V}$, Gain = 50x (LMP8602), Gain = 100x (LMP8603)

- TCV_{os} 10 $\mu\text{V}/^\circ\text{C}$ max
- CMRR 90 dB min
- Input offset voltage 1 mV max
- CMVR at $V_S = 3.3\text{V}$ -4V to 27V
- CMVR at $V_S = 5.0\text{V}$ -22V to 60V
- Operating ambient temperature range -40°C to 125°C
- Single supply bidirectional operation
- All Min / Max limits 100% tested
- LMP8602Q and LMP8603Q available in Automotive AEC-Q100 Grade 1 qualified version

Applications

- High side and low side driver configuration current sensing
- Bidirectional current measurement
- Current loop to voltage conversion
- Automotive fuel injection control
- Transmission control
- Power steering
- Battery management systems

Typical Applications

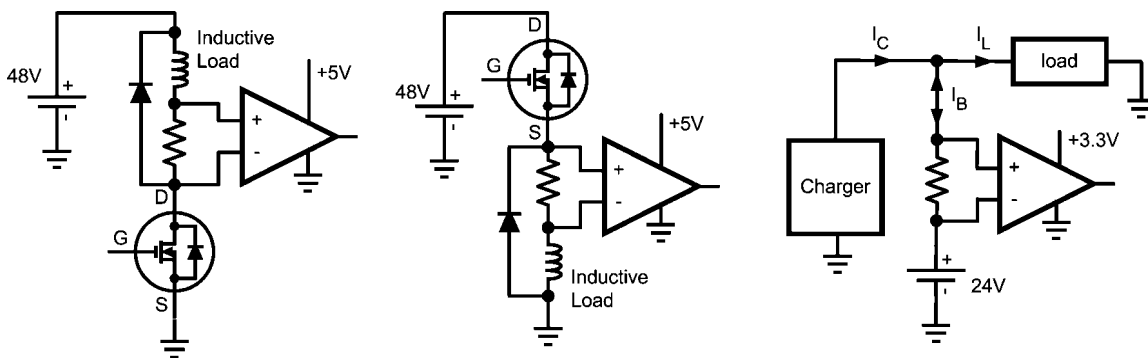

30083401

LMP™ is a trademark of National Semiconductor Corporation.

Absolute Maximum Ratings *(Note 1)*

If Military/Aerospace specified devices are required, please contact the National Semiconductor Sales Office/ Distributors for availability and specifications.

ESD Tolerance *(Note 4)*

Human Body

For input pins only	±4000V
For all other pins	±2000V

Machine Model	200V
Charge Device Model	1000V

Supply Voltage (V_S - GND) 6.0V

Continuous Input Voltage (-IN and +IN) *(Note 6)* -22V to 60V

Transient (400 ms) -25V to 65V

Maximum Voltage at A1, A2, OFFSET and OUT Pins $V_S +0.3V$ and GND -0.3V

Storage Temperature Range -65°C to 150°C

Junction Temperature *(Note 3)* 150°C

Mounting Temperature

Infrared or Convection (20 sec) 235°C

Wave Soldering Lead (10 sec) 260°C

Operating Ratings *(Note 1)*

Supply Voltage (V_S - GND) 3.0V to 5.5V

Offset Voltage (Pin 7) 0 to V_S

Temperature Range *(Note 3)*

Packaged devices -40°C to +125°C

Package Thermal Resistance *(Note 3)*

8-Pin SOIC (θ_{JA}) 190°C/W

8-Pin MSOP (θ_{JA}) 203°C/W

3.3V Electrical Characteristics *(Note 2)*

Unless otherwise specified, all limits guaranteed at $T_A = 25^\circ\text{C}$, $V_S = 3.3V$, GND = 0V, $-4V \leq V_{CM} \leq 27V$, and $R_L = \infty$, Offset (Pin 7) is grounded, 10nF between V_S and GND. **Boldface** limits apply at the temperature extremes.

Symbol	Parameter	Conditions	Min <i>(Note 7)</i>	Typ <i>(Note 5)</i>	Max <i>(Note 7)</i>	Units	
Overall Performance (From -IN (pin 1) and +IN (pin 8) to OUT (pin 5) with pins A1 (pin 3) and A2 (pin 4) connected)							
I_S	Supply Current			1	1.3	mA	
A_V	Total Gain	LMP8602	49.75	50	50.25	V/V	
		LMP8603	99.5	100	100.5		
	Gain Drift <i>(Note 15)</i>	$-40^\circ\text{C} \leq T_A \leq 125^\circ\text{C}$		-2.7	±20	ppm/°C	
SR	Slew Rate <i>(Note 8)</i>	$V_{IN} = \pm 0.165V$	0.4	0.7		V/μs	
BW	Bandwidth		50	60		kHz	
V_{OS}	Input Offset Voltage	$V_{CM} = V_S / 2$		0.15	±1	mV	
TCV_{OS}	Input Offset Voltage Drift <i>(Note 9)</i>	$-40^\circ\text{C} \leq T_A \leq 125^\circ\text{C}$		2	±10	μV/°C	
e_n	Input Referred Voltage Noise	0.1 Hz – 10 Hz, 6 Sigma		16.4		μV _{P-P}	
		Spectral Density, 1 kHz		830		nV/√Hz	
PSRR	Power Supply Rejection Ratio	DC, $3.0V \leq V_S \leq 3.6V$, $V_{CM} = V_S/2$	70	86		dB	
	Mid-scale Offset Scaling Accuracy	LMP8602		±0.25	±1	%	
			Input Referred			±0.33	mV
		LMP8603		±0.45	±1.5	%	
			Input Referred			±0.248	mV
Preamplifier (From input pins -IN (pin 1) and +IN (pin 8) to A1 (pin 3))							
R_{CM}	Input Impedance Common Mode	$-4V \leq V_{CM} \leq 27V$	250	295	350	kΩ	
R_{DM}	Input Impedance Differential Mode	$-4V \leq V_{CM} \leq 27V$	500	590	700	kΩ	
V_{OS}	Input Offset Voltage	$V_{CM} = V_S / 2$		±0.15	±1	mV	
DC CMRR	DC Common Mode Rejection Ratio	$-2V \leq V_{CM} \leq 24V$	86	96		dB	
AC CMRR	AC Common Mode Rejection Ratio <i>(Note 10)</i>	f = 1 kHz	80	94		dB	
		f = 10 kHz		85			
CMVR	Input Common Mode Voltage Range	for 80 dB CMRR	-4		27	V	
K1	Gain <i>(Note 15)</i>		9.95	10.0	10.05	V/V	
R_{F-INT}	Output Impedance Filter Resistor		99	100	101	kΩ	
TCR_{F-INT}	Output Impedance Filter Resistor Drift			±5	±50	ppm/°C	
A1 V_{OUT}	A1 Output Voltage Swing	V_{OL}	$R_L = \infty$		2	10	mV
		V_{OH}		3.2	3.25		V

Symbol	Parameter	Conditions	Min (Note 7)	Typ (Note 5)	Max (Note 7)	Units	
Output Buffer (From A2 (pin 4) to OUT (pin 5))							
V_{OS}	Input Offset Voltage	$0V \leq V_{CM} \leq V_S$	-2 -2.5	± 0.5	2 2.5	mV	
K_2	Gain (Note 15)	LMP8602	4.975	5	5.025	V/V	
		LMP8603	9.95	10	10.05		
I_B	Input Bias Current of A2 (Note 11)			-40		fA	
					± 20	nA	
$A_2 V_{OUT}$	A2 Output Voltage Swing (Note 12, Note 13)	V_{OL} , $R_L = 100 \text{ k}\Omega$	LMP8602		10	40	mV
			LMP8603		10	80	
		V_{OH} , $R_L = 100 \text{ k}\Omega$		3.28	3.29		V
I_{SC}	Output Short-Circuit Current (Note 14)	Sourcing, $V_{IN} = V_S$, $V_{OUT} = \text{GND}$	-25	-38	-60	mA	
		Sinking, $V_{IN} = \text{GND}$, $V_{OUT} = V_S$	30	46	65		

5V Electrical Characteristics (Note 2)

Unless otherwise specified, all limits guaranteed for at $T_A = 25^\circ\text{C}$, $V_S = 5\text{V}$, $\text{GND} = 0\text{V}$, $-22\text{V} \leq V_{CM} \leq 60\text{V}$, and $R_L = \infty$, Offset (Pin 7) is grounded, 10nF between V_S and GND. **Boldface** limits apply at the temperature extremes.

Symbol	Parameter	Conditions	Min (Note 7)	Typ (Note 5)	Max (Note 7)	Units
Overall Performance (From -IN (pin 1) and +IN (pin 8) to OUT (pin 5) with pins A1 (pin 3) and A2 (pin 4) connected)						
I_S	Supply Current			1.1	1.5	mA
A_V	Total Gain (Note 15)	LMP8602	49.75	50	50.25	V/V
		LMP8603	99.5	100	100.5	
	Gain Drift	$-40^\circ\text{C} \leq T_A \leq 125^\circ\text{C}$		-2.8	± 20	ppm/ $^\circ\text{C}$
SR	Slew Rate (Note 8)	$V_{IN} = \pm 0.25\text{V}$	0.6	0.83		V/ μs
BW	Bandwidth		50	60		kHz
V_{OS}	Input Offset Voltage			0.15	± 1	mV
TCV_{OS}	Input Offset Voltage Drift (Note 9)	$-40^\circ\text{C} \leq T_A \leq 125^\circ\text{C}$		2	± 10	$\mu\text{V}/^\circ\text{C}$
e_N	Input Referred Voltage Noise	0.1 Hz – 10 Hz, 6 Sigma		17.5		μV_{P-P}
		Spectral Density, 1 kHz		890		nV/ $\sqrt{\text{Hz}}$
PSRR	Power Supply Rejection Ratio	$\text{DC } 4.5\text{V} \leq V_S \leq 5.5\text{V}$	70	90		dB
	Mid-scale Offset Scaling Accuracy	LMP8602		± 0.25	± 1	%
			Input Referred			± 0.50
		LMP8603		± 0.45	± 1.5	%
			Input Referred			± 0.375
Preamplifier (From input pins -IN (pin 1) and +IN (pin 8) to A1 (pin 3))						
R_{CM}	Input Impedance Common Mode	$0\text{V} \leq V_{CM} \leq 60\text{V}$	250	295	350	k Ω
		$-20\text{V} \leq V_{CM} < 0\text{V}$	165	193	250	k Ω
R_{DM}	Input Impedance Differential Mode	$0\text{V} \leq V_{CM} \leq 60\text{V}$	500	590	700	k Ω
		$-20\text{V} \leq V_{CM} < 0\text{V}$	300	386	500	k Ω
V_{OS}	Input Offset Voltage	$V_{CM} = V_S / 2$		± 0.15	± 1	mV
DC CMRR	DC Common Mode Rejection Ratio	$-20\text{V} \leq V_{CM} \leq 60\text{V}$	90	105		dB
AC CMRR	AC Common Mode Rejection Ratio (Note 10)	$f = 1 \text{ kHz}$	80	96		dB
		$f = 10 \text{ kHz}$		83		
CMVR	Input Common Mode Voltage Range	for 80 dB CMRR	-22		60	V
K_1	Gain (Note 15)		9.95	10	10.05	V/V
R_{F-INT}	Output Impedance Filter Resistor		99	100	101	k Ω

Symbol	Parameter	Conditions	Min (Note 7)	Typ (Note 5)	Max (Note 7)	Units	
TCR _{F-INT}	Output Impedance Filter Resistor Drift			±5	±50	ppm/°C	
A1 V _{OUT}	A1 Output Voltage Swing	V _{OL}	R _L = ∞		2	10	mV
		V _{OH}		4.95	4.985		V
Output Buffer (From A2 (pin 4) to OUT (pin 5))							
V _{OS}	Input Offset Voltage	0V ≤ V _{CM} ≤ V _S	-2 -2.5	±0.5	2 2.5	mV	
K ₂	Gain (Note 15)	LMP8602	4.975	5	5.025	V/V	
		LMP8603	9.95	10	10.05		
I _B	Input Bias Current of A2 (Note 11)			-40		fA	
					±20	nA	
A2 V _{OUT}	A2 Output Voltage Swing (Note 12, Note 13)	V _{OL} , R _L = 100 kΩ	LMP8602		10	40	mV
			LMP8603		10	80	
		V _{OH} , R _L = 100 kΩ		4.98	4.99		V
I _{SC}	Output Short-Circuit Current (Note 14)	Sourcing, V _{IN} = V _S , V _{OUT} = GND	-25	-42	-60	mA	
		Sinking, V _{IN} = GND, V _{OUT} = V _S	30	48	65		

Note 1: "Absolute Maximum Ratings" indicate limits beyond which damage to the device may occur, including inoperability and degradation of the device reliability and/or performance. Functional operation of the device and/or non-degradation at the Absolute Maximum Ratings or other conditions beyond those indicated in the *Recommended Operating Conditions* is not implied. The *Recommended Operating Conditions* indicate conditions at which the device is functional and the device should not be beyond such conditions. All voltages are measured with respect to the ground pin, unless otherwise specified.

Note 2: The electrical Characteristics tables list guaranteed specifications under the listed *Recommended Operating Conditions* except as otherwise modified or specified by the *Electrical Characteristics Conditions* and/or Notes. Typical specifications are estimations only and are not guaranteed.

Note 3: The maximum power dissipation must be derated at elevated temperatures and is dictated by T_{J(MAX)}, θ_{JA}, and the ambient temperature, T_A. The maximum allowable power dissipation P_{DMAX} = (T_{J(MAX)} - T_A) / θ_{JA} or the number given in *Absolute Maximum Ratings*, whichever is lower.

Note 4: Human Body Model per MIL-STD-883, Method 3015.7. Machine Model, per JESD22-A115-A. Field-Induced Charge-Device Model, per JESD22-C101-C.

Note 5: Typical values represent the most likely parameter norms at T_A = +25°C, and at the *Recommended Operation Conditions* at the time of product characterization and are not guaranteed.

Note 6: For the MSOP package, the bare board spacing at the solder pads of the package will be too small for reliable use at higher voltages (V_{CM} > 25V). Therefore it is strongly advised to add a conformal coating on the PCB assembled with the LMP8602 and LMP8603.

Note 7: Datasheet min/max specification limits are guaranteed by test.

Note 8: Slew rate is the average of the rising and falling slew rates.

Note 9: Offset voltage drift determined by dividing the change in V_{OS} at temperature extremes into the total temperature change.

Note 10: AC Common Mode Signal is a 5V_{PP} sine-wave (0V to 5V) at the given frequency.

Note 11: Positive current corresponds to current flowing into the device.

Note 12: For this test input is driven from A1 stage in uni-directional mode (Offset pin connected to GND).

Note 13: For V_{OL}, R_L is connected to V_S and for V_{OH}, R_L is connected to GND.

Note 14: Short-Circuit test is a momentary test. Continuous short circuit operation at elevated ambient temperature can result in exceeding the maximum allowed junction temperature of 150°C.

Note 15: Both the gain of the preamplifier A_{1V} and the gain of the buffer amplifier A_{2V} are measured individually. The overall gain of both amplifiers A_V is also measured to assure the gain of all parts is always within the A_V limits.

Block Diagram

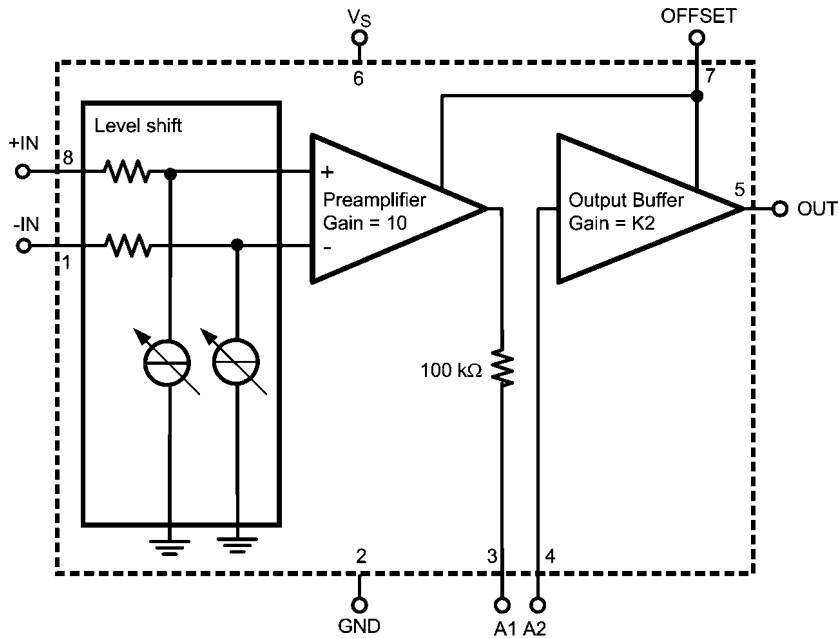

30083405

K2 = 5 for LMP8602, K2 = 10 for LMP8603

Connection Diagram

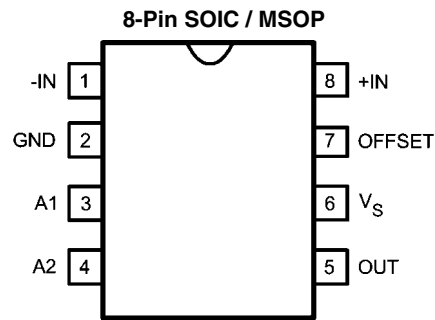

Top View

30083402

Pin Descriptions

	Pin	Name	Description
Power Supply	2	GND	Power Ground
	6	V _S	Positive Supply Voltage
Inputs	1	-IN	Negative Input
	8	+IN	Positive Input
Filter Network	3	A1	Preamplifier output
	4	A2	Input from the external filter network and / or A1
Offset	7	OFFSET	DC Offset for bidirectional signals
Output	5	OUT	Single ended output

Ordering Information

Package	Part Number	Package Marking	Transport Media	NSC Drawing
8-Pin SOIC	LMP8602MA	LMP8602MA	95 Units/Rail	M08A
	LMP8602MAX		2.5K Units Tape and Reel	
	LMP8602QMA	LMP8602QMA	95 Units/Rail	
	LMP8602QMAX		2.5K Units Tape and Reel	
8-Pin MSOP	LMP8602MM	AN3A	1k Units Tape and Reel	MUA08A
	LMP8602MMX		3.5K Units Tape and Reel	
	LMP8602QMM	AF7A	1k Units Tape and Reel	
	LMP8602QMMX		3.5K Units Tape and Reel	

Package	Part Number	Package Marking	Transport Media	NSC Drawing
8-Pin SOIC	LMP8603MA	LMP8603MA	95 Units/Rail	M08A
	LMP8603MAX		2.5K Units Tape and Reel	
	LMP8603QMA	LMP8603QMA	95 Units/Rail	
	LMP8603QMAX		2.5K Units Tape and Reel	
8-Pin MSOP	LMP8603MM	AP3A	1k Units Tape and Reel	MUA08A
	LMP8603MMX		3.5K Units Tape and Reel	
	LMP8603QMM	AH7A	1k Units Tape and Reel	
	LMP8603QMMX		3.5K Units Tape and Reel	

Automotive Grade (Q) product incorporates enhanced manufacturing and support processes for the automotive market, including defect detection methodologies. Reliability qualification is compliant with the requirements and temperature grades defined in the AEC Q100 standard. Automotive Grade products are identified with the letter Q. Fully compliant PPAP documentation is available. For more information, go to <http://www.national.com/automotive>.

Typical Performance Characteristics

Unless otherwise specified, all limits guaranteed for at $T_A = 25^\circ\text{C}$, $V_S = 5\text{V}$, $\text{GND} = 0\text{V}$, $-22\text{V} \leq V_{\text{CM}} \leq 60\text{V}$, and $R_L = \infty$, Offset (Pin 7) connected to V_S , 10nF between V_S and GND.

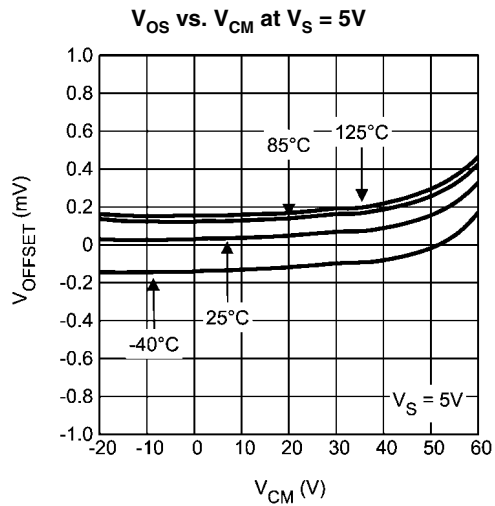
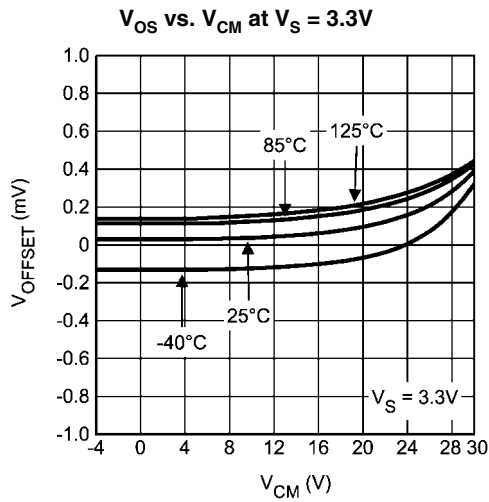

Input Bias Current Over Temperature (+IN and -IN pins) at $V_S = 3.3\text{V}$

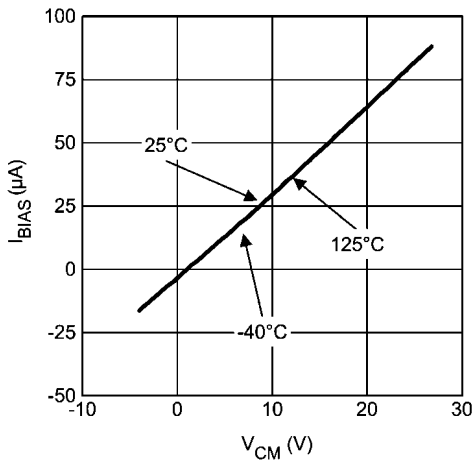

Input Bias Current Over Temperature (+IN and -IN pins) at $V_S = 5\text{V}$

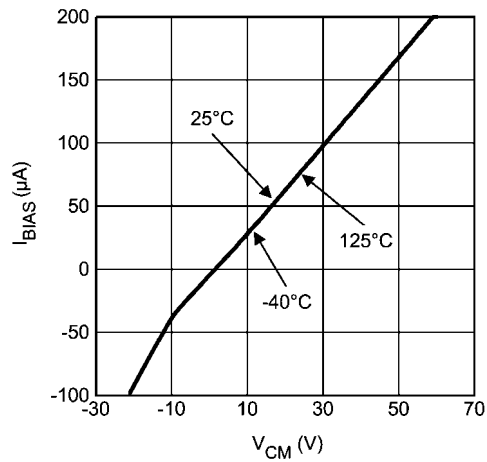

Input Bias Current Over Temperature (A2 pin) at $V_S = 5\text{V}$

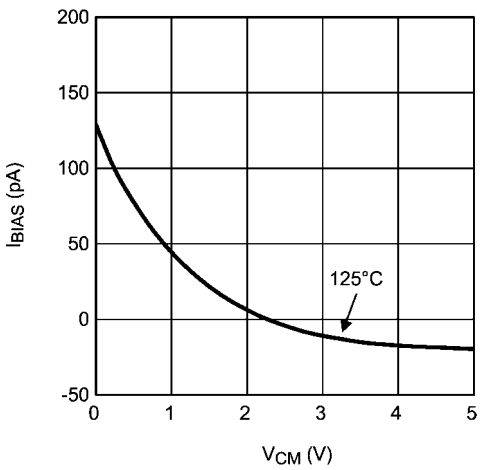

Input Bias Current Over Temperature (A2 pin) at $V_S = 5\text{V}$

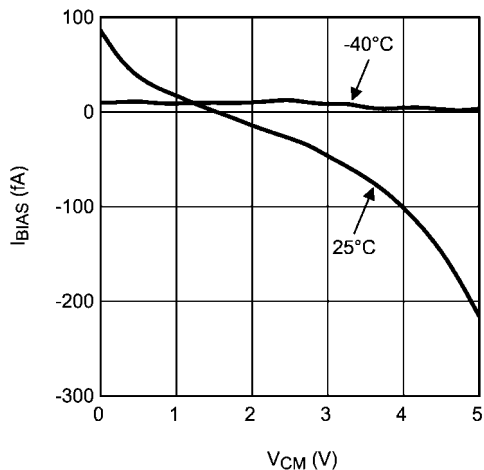

Input Referred Voltage Noise vs. Frequency

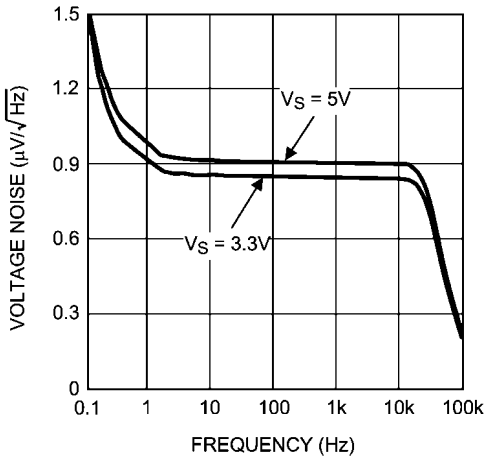

30083410

PSRR vs. Frequency

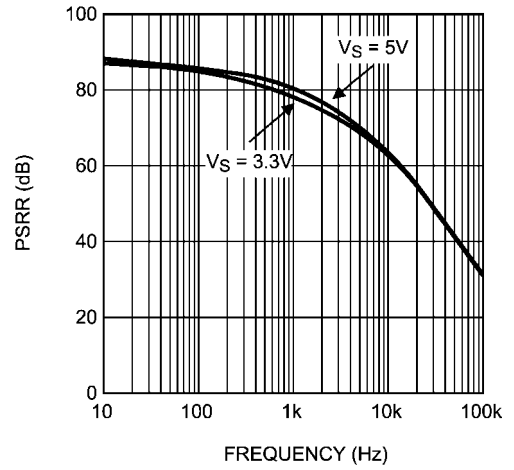

30083417

Gain vs. Frequency LMP8602

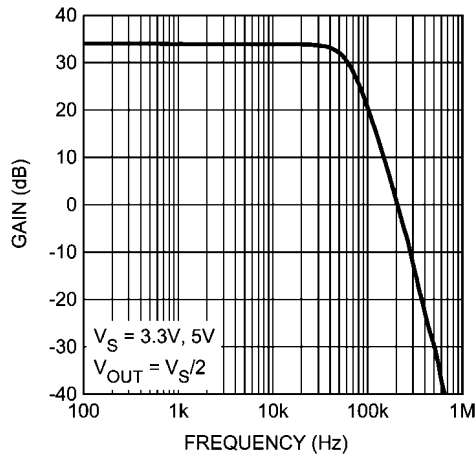

30083411

Gain vs. Frequency LMP8603

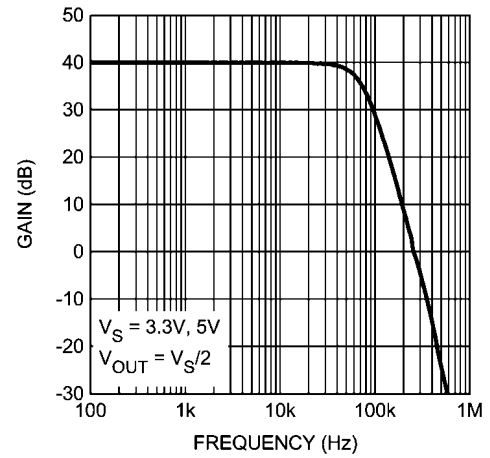

30083412

CMRR vs. Frequency at VS = 3.3V

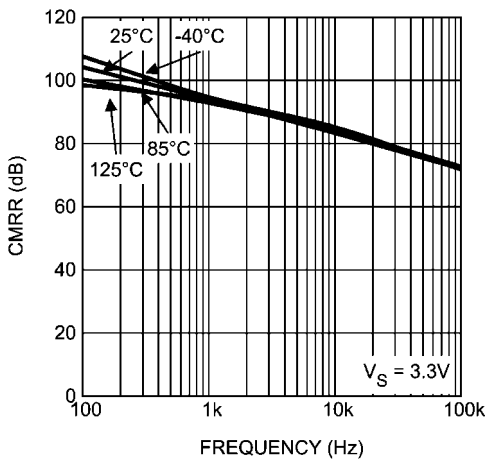

30083428

CMRR vs. Frequency at VS = 5V

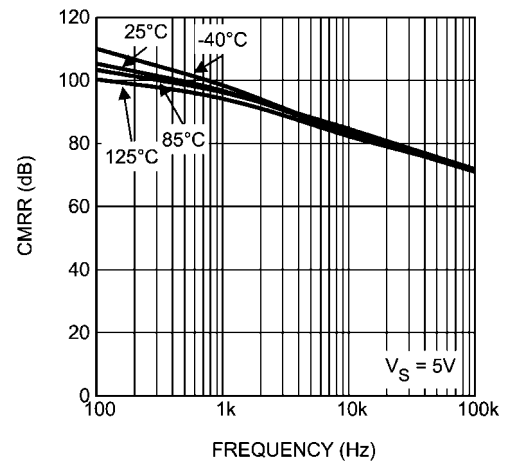

30083429

**Step Response at $V_S = 3.3V$
 $R_L = 10k\Omega$ LMP8602**

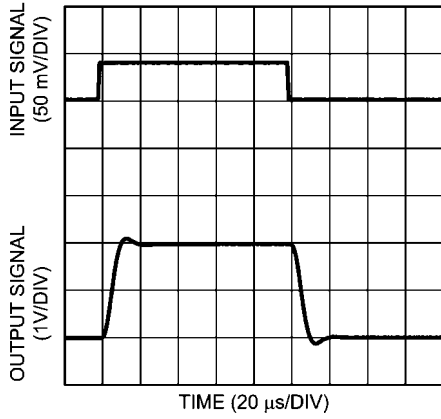

30083418

**Step Response at $V_S = 5V$
 $R_L = 10k\Omega$ LMP8602**

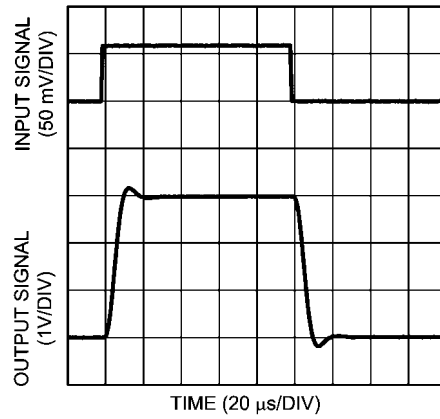

30083419

**Settling Time (Falling Edge) at $V_S = 3.3V$
LMP8602**

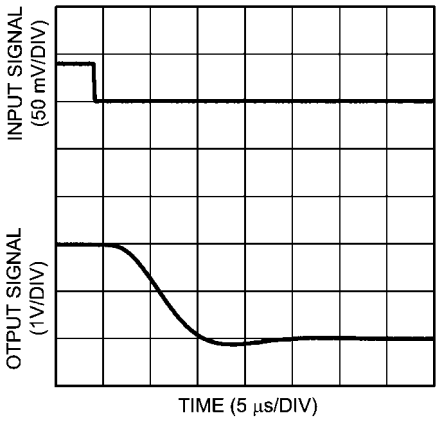

30083420

**Settling Time (Falling Edge) at $V_S = 5V$
LMP8602**

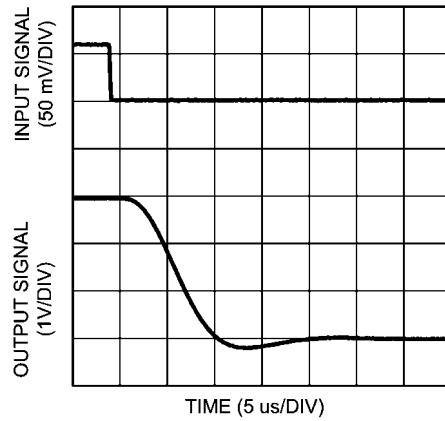

30083421

**Settling Time (Rising Edge) at $V_S = 3.3V$
LMP8602**

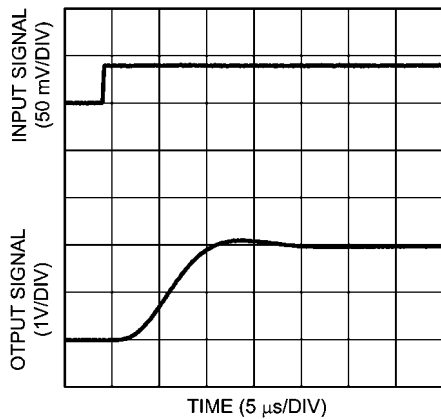

30083422

**Settling Time (Rising Edge) at $V_S = 5V$
LMP8602**

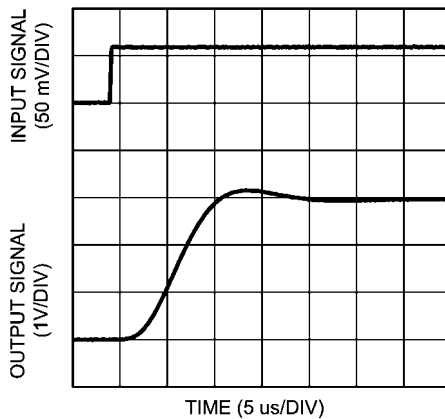

30083423

Step Response at $V_S = 3.3V$
 $R_L = 10k\Omega$ LMP8603

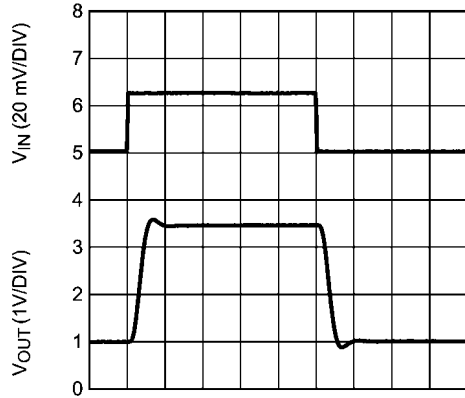

TIME (20 us/DIV)

30083443

Step Response at $V_S = 5V$
 $R_L = 10k\Omega$ LMP8603

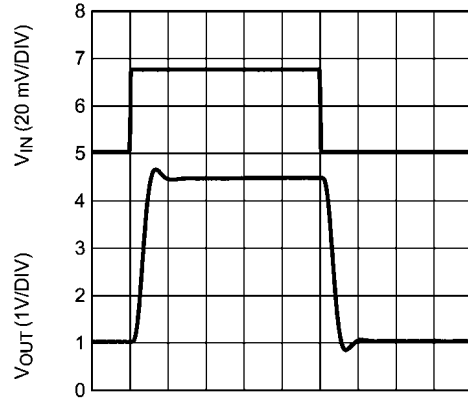

TIME (20 us/DIV)

30083444

Settling Time (Falling Edge) at $V_S = 3.3V$
 LMP8603

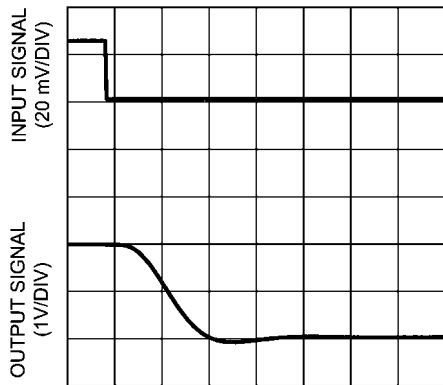

TIME (5 us/DIV)

30083445

Settling Time (Falling Edge) at $V_S = 5V$
 LMP8603

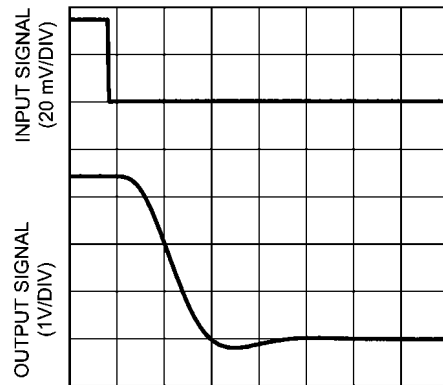

TIME (5 us/DIV)

30083446

Settling Time (Rising Edge) at $V_S = 3.3V$
 LMP8603

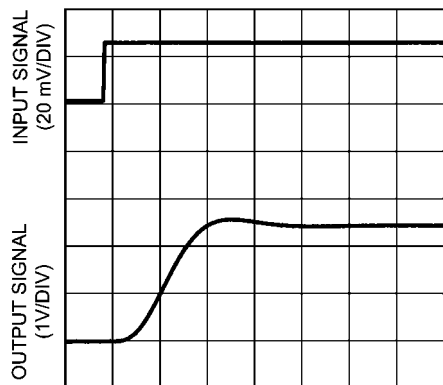

TIME (5 us/DIV)

30083447

Settling Time (Rising Edge) at $V_S = 5V$
 LMP8603

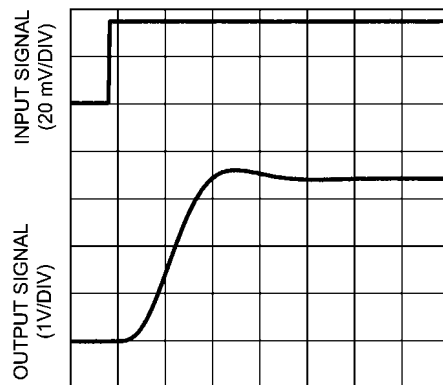

TIME (5 us/DIV)

30083448

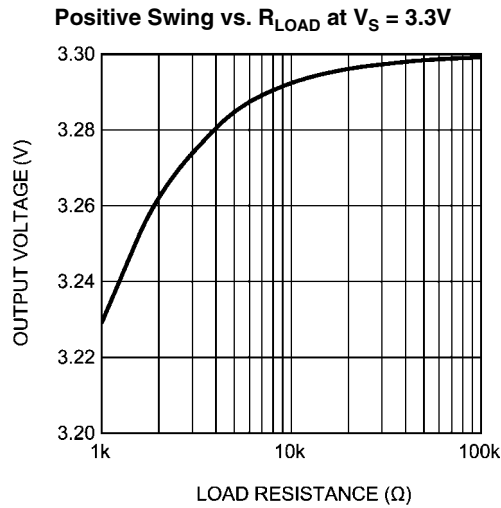

30083413

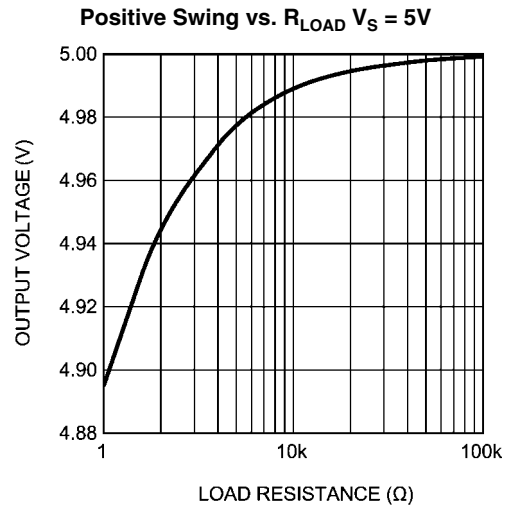

30083415

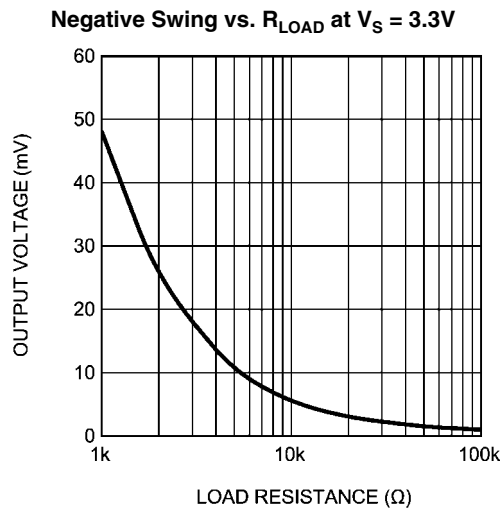

30083414

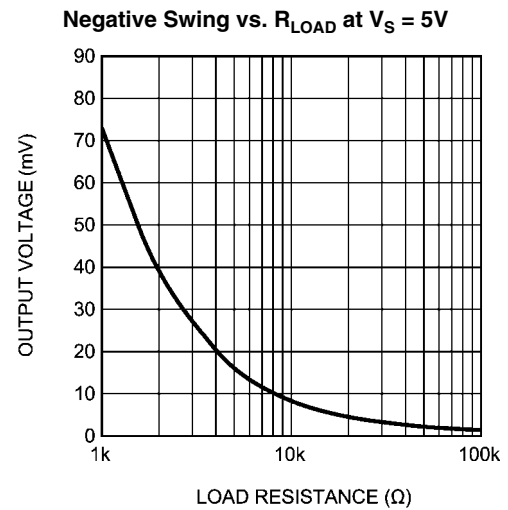

30083416

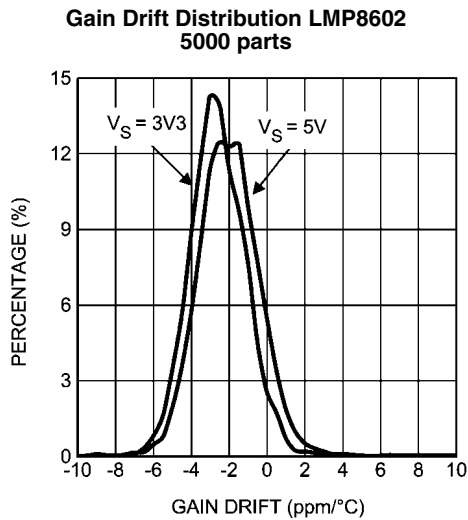

30083437

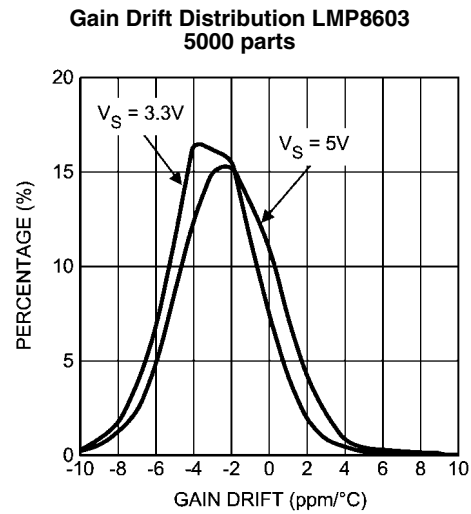

30083483

**Gain error Distribution at $V_S = 3.3V$ LMP8602
5000 parts**

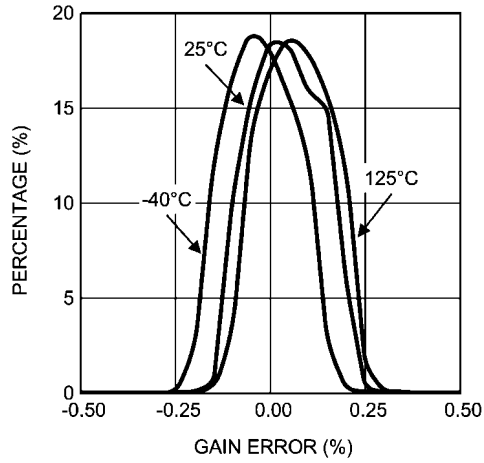

30083438

**Gain error Distribution at $V_S = 3.3V$ LMP8603
5000 parts**

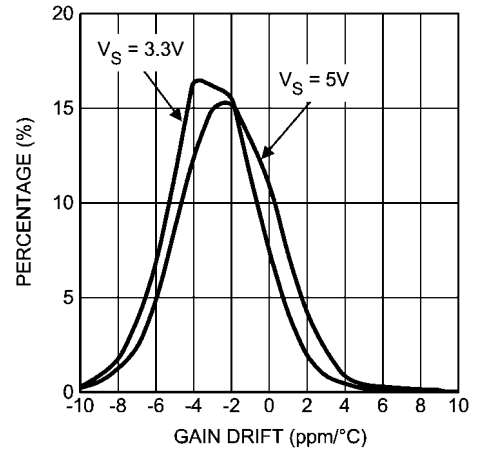

30083484

**Gain error Distribution at $V_S = 5V$ LMP8602
5000 parts**

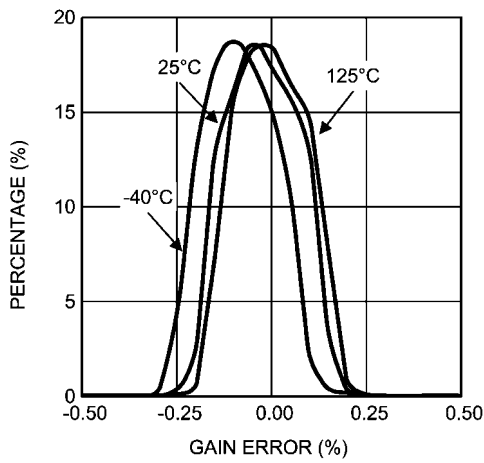

30083439

**Gain error Distribution at $V_S = 5V$ LMP8603
5000 parts**

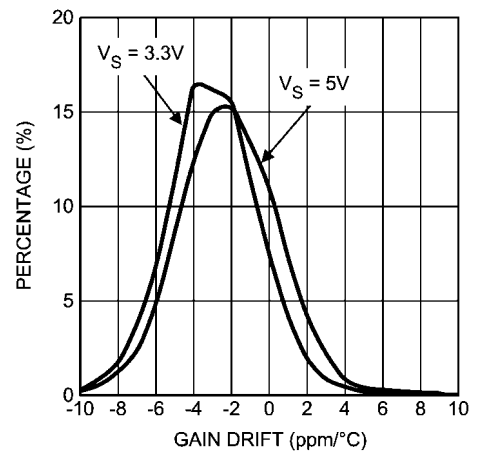

30083485

**CMRR Distribution at $V_S = 3.3V$
5000 parts**

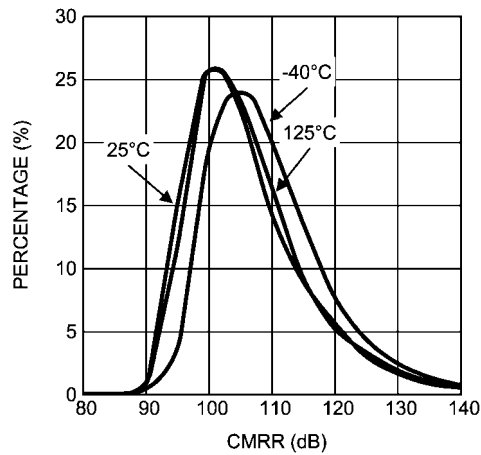

30083432

**CMRR Distribution at $V_S = 5V$
5000 parts**

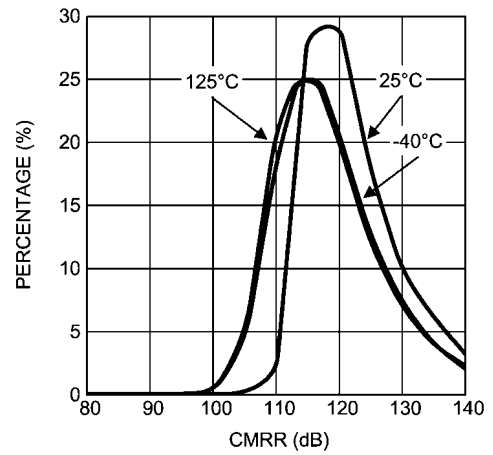

30083433

**V_{OS} Distribution at V_S = 3.3V
5000 parts**

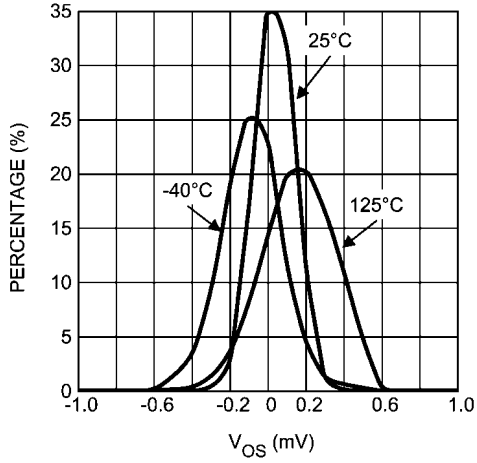

30083434

**V_{OS} Distribution at V_S = 5V
5000 parts**

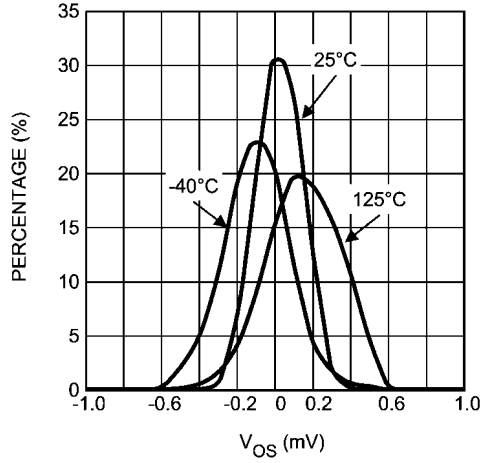

30083435

**TCV_{OS} Distribution
5000 parts**

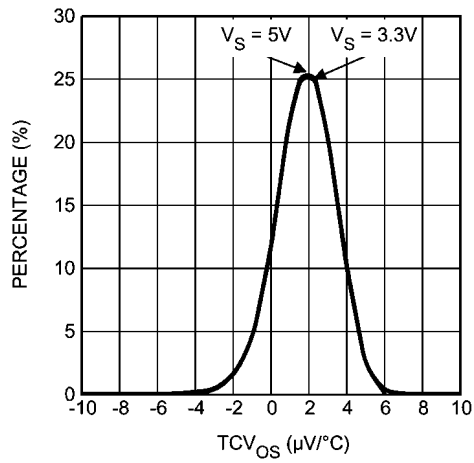

30083436

Application Information

GENERAL

The LMP8602 and LMP8603 are fixed gain differential voltage precision amplifiers with a gain of 50x for the LMP8602, and 100x for the LMP8603. The input common mode voltage range is -22V to +60V when operating from a single 5V supply or -4V to +27V input common mode voltage range when operating from a single 3.3V supply. The LMP8602 and LMP8603 are members of the LMP family and are ideal parts for unidirectional and bidirectional current sensing applications. Because of the proprietary chopping level-shift input stage the LMP8602 and LMP8603 achieve very low offset, very low thermal offset drift, and very high CMRR. The LMP8602 and LMP8603 will amplify and filter small differential signals in the presence of high common mode voltages.

The LMP8602/LMP8602Q/LMP8603/LMP8603Q use level shift resistors at the inputs. Because of these resistors, the LMP8602/LMP8602Q/LMP8603/LMP8603Q can easily withstand very large differential input voltages that may exist in fault conditions where some other less protected high-performance current sense amplifiers might sustain permanent damage.

PERFORMANCE GUARANTIES

To guaranty the high performance of the LMP8602/LMP8602Q/LMP8603/LMP8603Q, all minimum and maximum values shown in the parameter tables of this datasheet are 100% tested where all bold limits are also 100% tested over temperature.

THEORY OF OPERATION

The schematic shown in *Figure 1* gives a schematic representation of the internal operation of the LMP8602/LMP8603.

The signal on the input pins is typically a small differential voltage across a current sensing shunt resistor. The input signal may appear at a high common mode voltage. The input signals are accessed through two input resistors. The proprietary chopping level-shift current circuit pulls or pushes current through the input resistors to bring the common mode voltage behind these resistors within the supply rails. Subsequently, the signal is gained up by a factor of 10 (K_1) and brought out on the A1 pin through a trimmed 100 k Ω resistor. In the application, additional gain adjustment or filtering components can be added between the A1 and A2 pins as will be explained in subsequent sections. The signal on the A2 pin is further amplified by a factor (K_2) which equals a factor of 5 for the LMP8602 and a factor of 10 for the LMP8603. The output signal of the final gain stage is provided on the OUT pin. The OFFSET pin allows the output signal to be level-shifted to enable bidirectional current sensing as will be explained below.

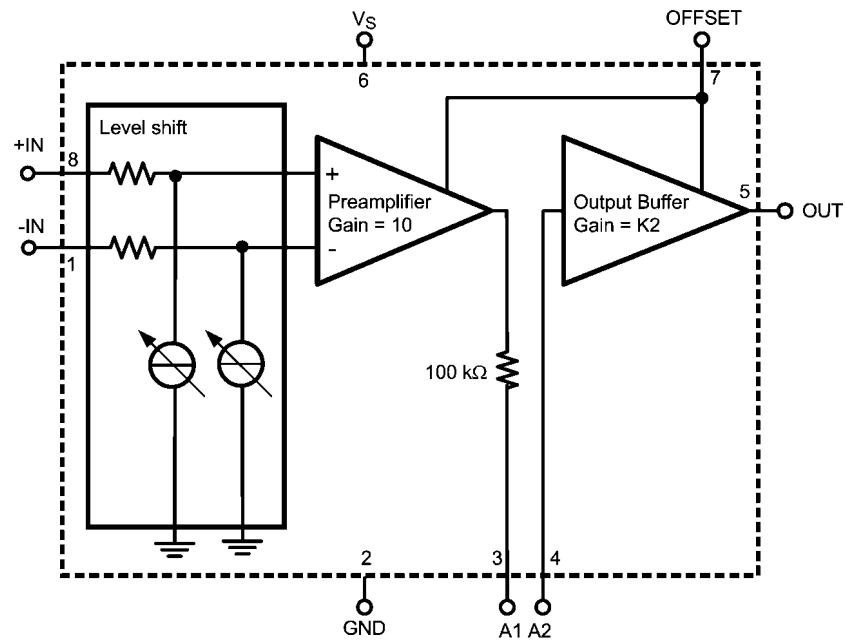

$K_2 = 5$ for LMP8602, $K_2 = 10$ for LMP8603

30083405

FIGURE 1. Theory of Operation

ADDITIONAL SECOND ORDER LOW PASS FILTER

The LMP8602/LMP8602Q/LMP8603/LMP8603Q has a third order Butterworth low-pass characteristic with a typical bandwidth of 60 kHz integrated in the preamplifier stage of the part. The bandwidth of the output buffer can be reduced by adding a capacitor on the A1 pin to create a first order low pass filter with a time constant determined by the 100 kΩ internal resistor and the external filter capacitor.

It is also possible to create an additional second order Sallen-Key low pass filter as shown in *Figure 2* by adding external components R₂, C₁ and C₂. Together with the internal 100 kΩ resistor R₁, this circuit creates a second order low-pass filter characteristic.

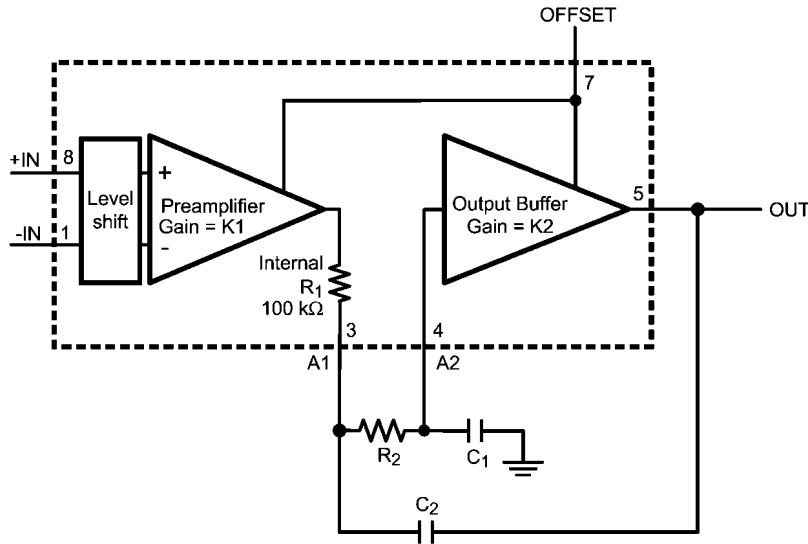

K1 = 10, K2 = 5 for LMP8602, K2 = 10 for LMP8603

30083455

FIGURE 2. Second Order Low Pass Filter

When the corner frequency of the additional filter is much lower than 60 kHz, the transfer function of the described amplifier can be written as:

$$H(s) = \frac{K_1 * K_2}{s^2 + s * \left[\frac{1}{R_1 C_2} + \frac{1}{R_2 C_2} + \frac{(1 - K_2)}{R_2 C_1} \right] + \frac{1}{R_1 R_2 C_1 C_2}}$$

Where K₁ equals the gain of the preamplifier and K₂ that of the buffer amplifier.

The above equation can be written in the normalized frequency response for a 2nd order low pass filter:

$$G(j\omega) = K_1 * \frac{K_2}{\frac{(j\omega)^2}{\omega_0^2} + \frac{j\omega}{Q\omega_0} + 1}$$

The Cutt-off frequency ω₀ in rad/sec (divide by 2π to get the cut-off frequency in Hz) is given by:

$$\omega_0 = \frac{1}{\sqrt{R_1 R_2 C_1 C_2}}$$

And the quality factor of the filter is given by:

$$Q = \frac{\sqrt{R_1 R_2 C_1 C_2}}{R_1 C_1 + R_2 C_1 + (1 - K_2) * R_1 C_2}$$

For any filter gain K > 1x, the design procedure can be very simple if the two capacitors are chosen to in a certain ratio.

$$C_2 = \frac{C_1}{K_2 - 1}$$

Inserting this in the above equation for Q results in:

$$Q = \frac{\sqrt{R_1 R_2} \frac{C_1^2}{K_2 - 1}}{R_1 C_1 + R_2 C_1 - \frac{(K_2 - 1) R_1 C_1}{K_2 - 1}}$$

Which results in:

$$Q = \frac{\sqrt{R_1 R_2} \frac{C_1^2}{K_2 - 1}}{C_1 R_2} = \frac{\sqrt{R_1 R_2}}{R_2}$$

In this case, given the predetermined value of R1 = 100 kΩ (the internal resistor), the quality factor is set solely by the value of the resistor R₂.

R_2 can be calculated based on the desired value of Q as the first step of the design procedure with the following equation:

$$R_2 = \frac{R_1}{(K - 1)Q^2}$$

For the gain of 5 for the LMP8602 this results in:

$$R_2 = \frac{R_1}{4Q^2}$$

For the gain of 10 for the LMP8603 this is:

$$R_2 = \frac{R_1}{9Q^2}$$

For instance, the value of Q can be set to $0.5\sqrt{2}$ to create a Butterworth response, to $1/\sqrt{3}$ to create a Bessel response, or a 0.5 to create a critically damped response. Once the value of R_2 has been found, the second and last step of the design procedure is to calculate the required value of C to give the desired low-pass cut-off frequency using:

$$C_1 = \frac{(K_2 - 1)Q}{R_1\omega_0}$$

Which for the gain = 5 will give:

$$C_1 = \frac{4Q}{R_1\omega_0}$$

and for the gain = 10:

$$C_1 = \frac{9Q}{R_1\omega_0}$$

For C_2 the value is calculated with:

$$C_2 = \frac{C_1}{K_2 - 1}$$

Or for a gain = 5:

$$C_2 = \frac{C_1}{4}$$

and for a gain = 10:

$$C_2 = \frac{C_1}{9}$$

Note that the frequency response achieved using this procedure will only be accurate if the cut-off frequency of the second order filter is much smaller than the intrinsic 60 kHz low-pass filter. In other words, to have the frequency response of the LMP8602/LMP8602Q/LMP8603/LMP8603Q circuit chosen such that the internal poles do not affect the external second order filter.

For a desired $Q = 0.707$ and a cut off frequency = 3 kHz, this will result for the LMP8602 in rounded values for $R_2 = 51 \text{ k}\Omega$, $C_1 = 1.5 \text{ nF}$ and $C_2 = 3.9 \text{ nF}$

And for the LMP8603 this will result in rounded values for $R_2 = 22 \text{ k}\Omega$, $C_1 = 3.3 \text{ nF}$ and $C_2 = 0.39 \text{ nF}$

GAIN ADJUSTMENT

The gain of the LMP8602 is 50 and the gain of the LMP8603 is 100, however, this gain can be adjusted as the signal path in between the two internal amplifiers is available on the external pins.

Reduce Gain

Figure 3 shows the configuration that can be used to reduce the gain of the LMP8602 and the LMP8603 in unidirectional sensing applications.

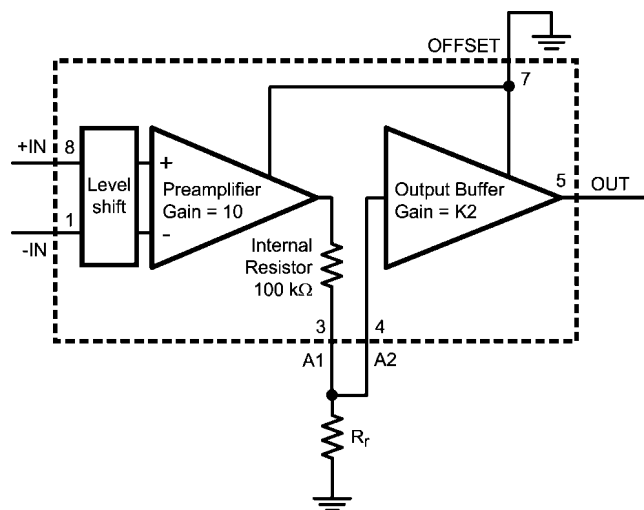

30083456

FIGURE 3. Reduce Gain for Unidirectional Application

R_r creates a resistive divider together with the internal 100 k Ω resistor such that, for the LMP8602, the reduced gain G_r becomes:

$$G_r = \frac{50 R_r}{R_r + 100 \text{ k}\Omega}$$

For the LMP8603:

$$G_r = \frac{100 R_r}{R_r + 100 \text{ k}\Omega}$$

Given a desired value of the reduced gain G_r , using this equation the required value for R_r can be calculated for the LMP8602 with:

$$R_r = 100 \text{ k}\Omega \times \frac{G_r}{50 - G_r}$$

and for the LMP8603 with:

$$R_r = 100 \text{ k}\Omega \times \frac{G_r}{100 - G_r}$$

Figure 4 shows the configuration that can be used to reduce the gain of the LMP8602 and the LMP8603 in bidirectional sensing applications. The required value for R_r can be calculated with the equations above. The maximum mid-scale offset scaling accuracy of the LMP8602 is $\pm 1\%$ and the maximum mid-scale offset scaling accuracy of the LMP8603 is $\pm 1.5\%$. The pair of resistors selected have to match much better than 1% and 1.5% to prevent a significant error contribution to the offset voltage.

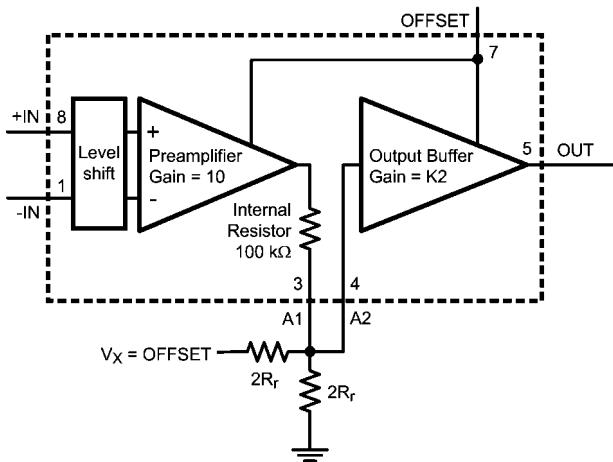

30083486

FIGURE 4. Reduce Gain for Bidirectional Application

Increase Gain

Figure 5 shows the configuration that can be used to increase the gain of the LMP8602/LMP8602Q/LMP8603/LMP8603Q. R_i creates positive feedback from the output pin to the input of the buffer amplifier. The positive feedback increases the gain. The increased gain G_i for the LMP8602 becomes:

$$G_i = \frac{50 R_i}{R_i - 400 \text{ k}\Omega}$$

and for the LMP8603:

$$G_i = \frac{100 R_i}{R_i - 900 \text{ k}\Omega}$$

From this equation, for a desired value of the gain, the required value of R_i can be calculated for the LMP8602 with:

$$R_i = 400 \text{ k}\Omega \times \frac{G_i}{G_i - 50}$$

and for the LMP8603 with:

$$R_i = 900 \text{ k}\Omega \times \frac{G_i}{G_i - 100}$$

It should be noted from the equation for the gain G_i that for large gains R_i approaches $100 \text{ k}\Omega \times (K_2 - 1)$. In this case, the denominator in the equation becomes close to zero. In practice, for large gains the denominator will be determined by tolerances in the values of the external resistor R_i and the internal 100 k Ω resistor, and the K_2 gain error. In this case, the gain becomes very inaccurate. If the denominator becomes equal to zero, the system will even become unstable. It is recommended to limit the application of this technique to gain increases of a factor 2.5 or smaller.

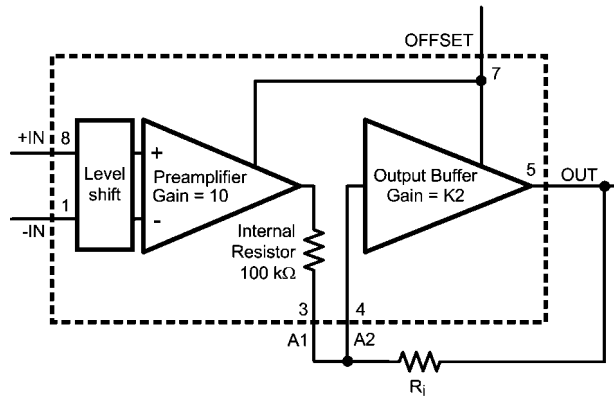

30083457

FIGURE 5. Increase Gain

BIDIRECTIONAL CURRENT SENSING

The signal on the A1 and OUT pins is ground-referenced when the OFFSET pin is connected to ground. This means that the output signal can only represent positive values of the current through the shunt resistor, so only currents flowing in one direction can be measured. When the offset pin is tied to the positive supply rail, the signal on the A1 and OUT pins is referenced to a mid-rail voltage which allows bidirectional current sensing. When the offset pin is connected to a voltage source, the output signal will be level shifted to that voltage divided by two. In principle, the output signal can be shifted to any voltage between 0 and $V_S/2$ by applying twice that voltage from a low impedance source (*Note 16*) to the OFFSET pin.

With the offset pin connected to the supply pin (V_S) the operation of the amplifier will be fully bidirectional and symmetrical around 0V differential at the input pins. The signal at the output will follow this voltage difference multiplied by the gain and at an offset voltage at the output of half V_S .

Example:

With 5V supply and a gain of 50x for the LMP8602, a differential input signal of +10 mV will result in 3.0V at the output pin. Similarly -10 mV at the input will result in 2.0V at the output pin.

With 5V supply and a gain of 100x for the LMP8603, a differential input signal of +10 mV will result in 3.5V at the output pin. Similarly -10 mV at the input will result in 1.5V at the output pin.

Note 16: The OFFSET pin has to be driven from a very low-impedance source ($<10\Omega$). This is because the OFFSET pin internally connects directly to the resistive feedback networks of the two gain stages. When the OFFSET pin is driven from a relatively large impedance (e.g. a resistive divider between the supply rails) accuracy will decrease.

POWER SUPPLY DECOUPLING

In order to decouple the LMP8602/LMP8602Q/LMP8603/LMP8603Q from AC noise on the power supply, it is recommended to use a 0.1 μF bypass capacitor between the V_S and GND pins. This capacitor should be placed as close as possible to the supply pins. In some cases an additional 10 μF bypass capacitor may further reduce the supply noise.

LAYOUT CONSIDERATIONS

The two input signals of the LMP8602/LMP8602Q/LMP8603/LMP8603Q are differential signals and should be handled as a differential pair. For optimum performance these signals should be closely together and of equal length. Keep all impedances in both traces equal and do not allow any other signal or ground in between the traces of this signals.

The connection between the preamplifier and the output buffer amplifier is a high impedance signal due to the 100 $\text{k}\Omega$ series resistor at the output of the preamplifier. Keep the traces at this point as short as possible and away from interfering signals.

The LMP8602/LMP8602Q/LMP8603/LMP8603Q is available in a 8-Pin SOIC package and in a 8-Pin MSOP package. For the MSOP package, the bare board spacing at the solder pads of the package will be too small for reliable use at higher voltages ($V_{CM} > 25\text{V}$). In this situation it is strongly advised to add a conformal coating on the PCB assembled with the LMP8602/LMP8602Q/LMP8603/LMP8603Q in MSOP package.

DRIVING SWITCHED CAPACITIVE LOADS

Some ADCs load their signal source with a sample and hold capacitor. The capacitor may be discharged prior to being

connected to the signal source. If the LMP8602/LMP8602Q/LMP8603/LMP8603Q is driving such ADCs the sudden current that should be delivered when the sampling occurs may disturb the output signal. This effect was simulated with the circuit shown in *Figure 6* where the output is connected to a capacitor that is driven by a rail to rail square wave.

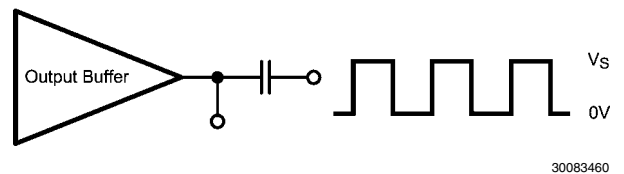

FIGURE 6. Driving Switched Capacitive Load

This circuit simulates the switched connection of a discharged capacitor to the LMP8602/LMP8602Q/LMP8603/LMP8603Q output. The resulting V_{OUT} disturbance signals are shown in *Figure 7* and *Figure 8*.

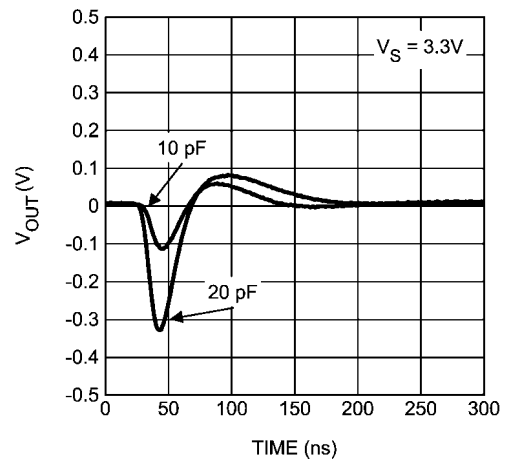

FIGURE 7. Capacitive Load Response at 3.3V

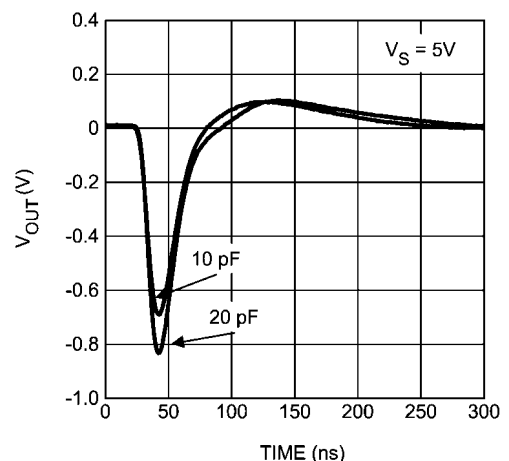

FIGURE 8. Capacitive Load Response at 5.0V

These figures can be used to estimate the disturbance that will be caused when driving a switched capacitive load. To minimize the error signal introduced by the sampling that occurs on the ADC input, an additional RC filter can be placed in between the LMP8602/LMP8602Q/LMP8603/LMP8603Q and the ADC as illustrated in [Figure 9](#).

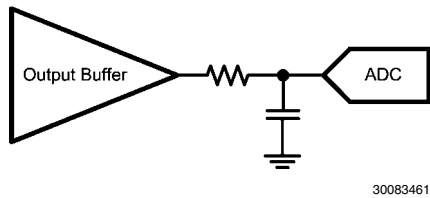

FIGURE 9. Reduce Error When Driving ADCs

The external capacitor absorbs the charge that flows when the ADC sampling capacitor is connected. The external capacitor should be much larger than the sample and hold capacitor at the input of the ADC and the RC time constant of the external filter should be such that the speed of the system is not affected.

LOW SIDE CURRENT SENSING APPLICATION WITH LARGE COMMON MODE TRANSIENTS

[Figure 10](#) illustrates a low side current sensing application with a low side driver. The power transistor is pulse width

modulated to control the average current flowing through the inductive load which is connected to a relatively high battery voltage. The current through the load is measured across a shunt resistor R_{SENSE} in series with the load. When the power transistor is on, current flows from the battery through the inductive load, the shunt resistor and the power transistor to ground. In this case, the common mode voltage on the shunt is close to ground. When the power transistor is off, current flows through the inductive load, through the shunt resistor and through the freewheeling diode. In this case the common mode voltage on the shunt is at least one diode voltage drop above the battery voltage. Therefore, in this application the common mode voltage on the shunt is varying between a large positive voltage and a relatively low voltage. Because the large common mode voltage range of the LMP8602/LMP8603 and because of the high AC common mode rejection ratio, the LMP8602/LMP8603 is very well suited for this application.

For this application the following example can be used for the calculation of the output signal:

When using a sense resistor, R_{SENSE} , of 0.01Ω and a current of 1A, then the output voltage at the input pins of the LMP8602 is: $R_{SENSE} * I_{LOAD} = 0.01 \Omega * 1A = 0.01V$

With the gain of 50 for the LMP8602 this will give an output of 0.5V. Or in other words, $V_{OUT} = 0.5V/A$.

For the LMP8603 the calculation is similar, but with a gain of 100, giving an output of 1 V/A.

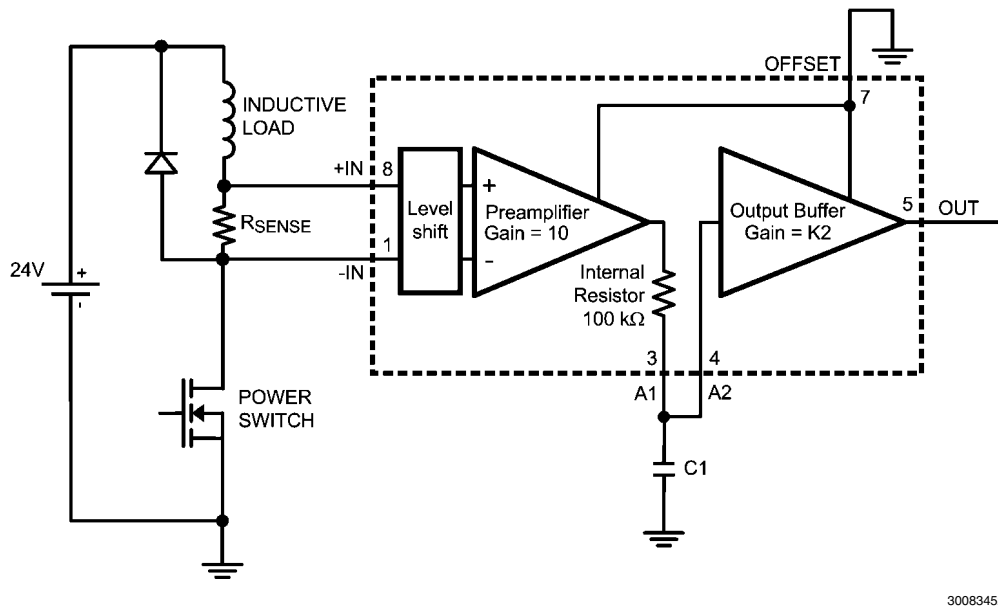
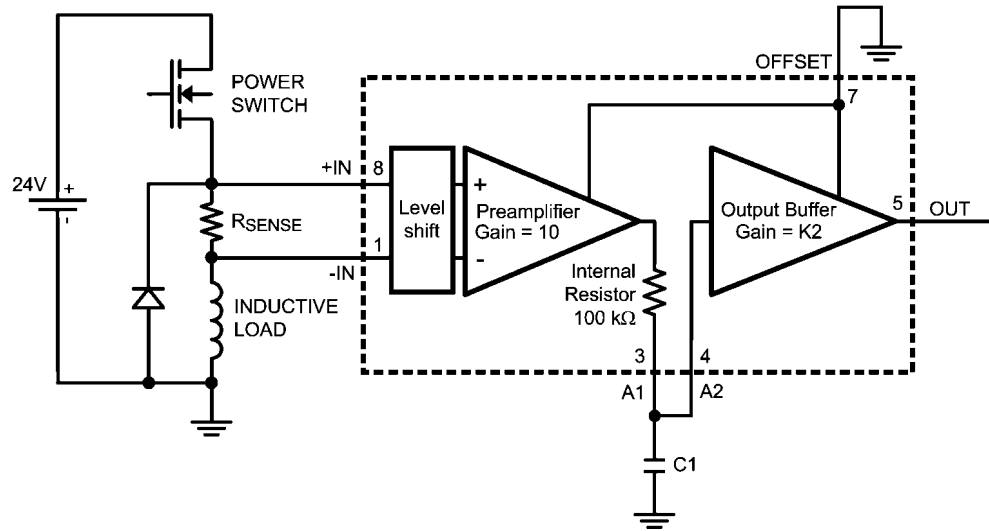

FIGURE 10. Low Side Current Sensing Application with Large Common Mode Transients

HIGH SIDE CURRENT SENSING APPLICATION WITH NEGATIVE COMMON MODE TRANSIENTS

Figure 11 illustrates the application of the LMP8602/LMP8603 in a high side sensing application. This application is similar to the low side sensing discussed above, except in

this application the common mode voltage on the shunt drops below ground when the driver is switched off. Because the common mode voltage range of the LMP8602/LMP8603 extends below the negative rail, the LMP8602/LMP8603 is also very well suited for this application.



30083453

FIGURE 11. High Side Current Sensing Application with Negative Common Mode Transients

BATTERY CURRENT MONITOR APPLICATION

This application example shows how the LMP8602/LMP8603 can be used to monitor the current flowing in and out a battery pack. The fact that the LMP8602/LMP8603 can measure small voltages at a high offset voltage outside the parts own supply range makes this part a very good choice

for such applications. If the load current of the battery is higher then the charging current, the output voltage of the LMP8602/LMP8603 will be above the "half offset voltage" for a net current flowing out of the battery. When the charging current is higher then the load current the output will be below this "half offset voltage".

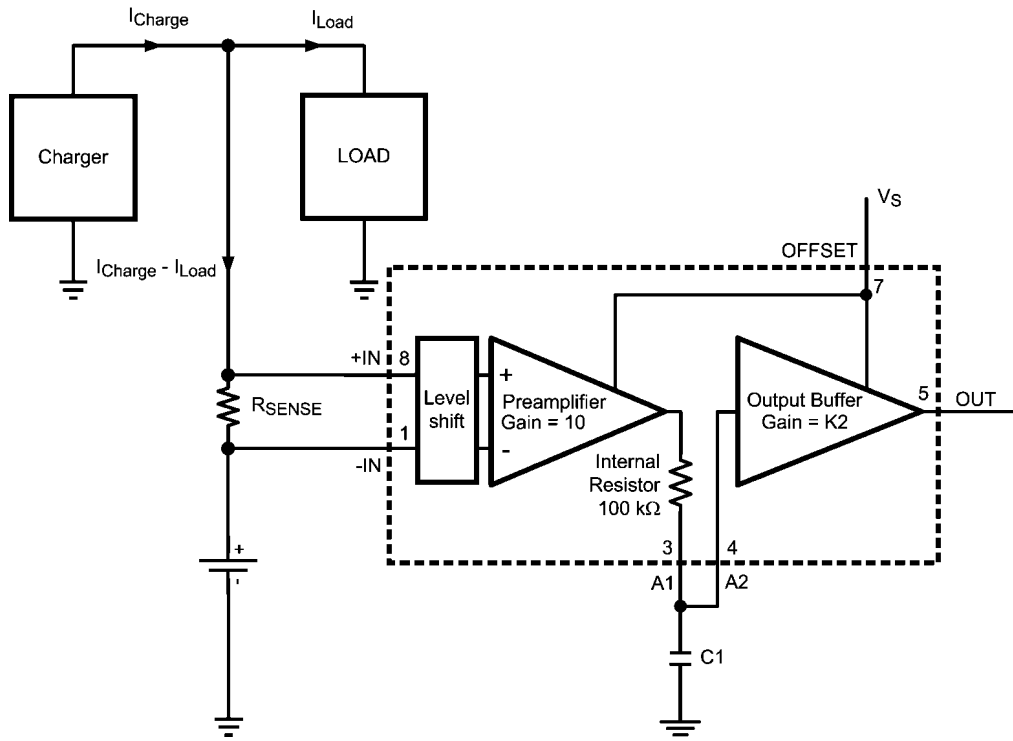

30083454

FIGURE 12. Battery Current Monitor Application

ADVANCED BATTERY CHARGER APPLICATION

The above circuit can be used to realize an advanced battery charger that has the capability to monitor the exact net current that flows in and out the battery as show in *Figure 13*. The output signal of the LMP8602/LMP8602Q/LMP8603/LM-

P8603Q is digitized with the A/D converter and used as an input for the charge controller. The charge controller can be used to regulate the charger circuit to deliver exactly the current that is required by the load, avoiding overcharging a fully loaded battery.

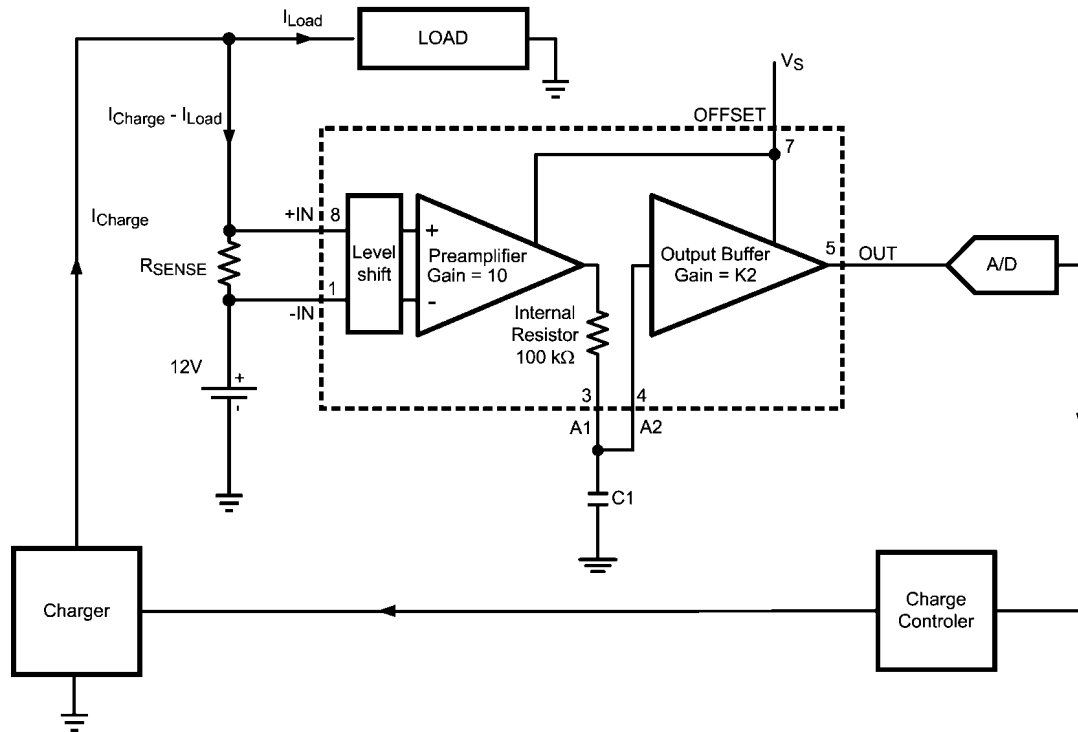

K2 = 5 for LMP8602
K2 = 10 for LMP8603

30083403

FIGURE 13. Advanced Battery Charger Application

Physical Dimensions inches (millimeters) unless otherwise noted

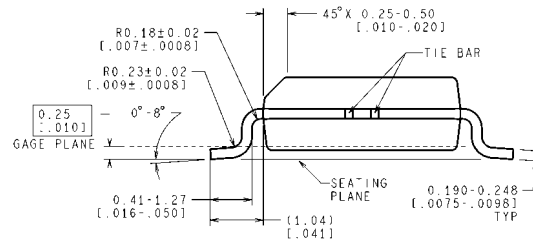
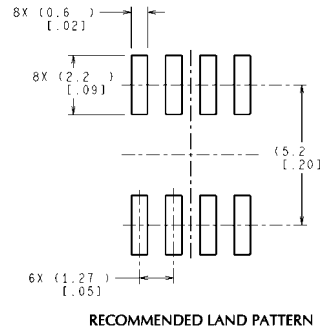
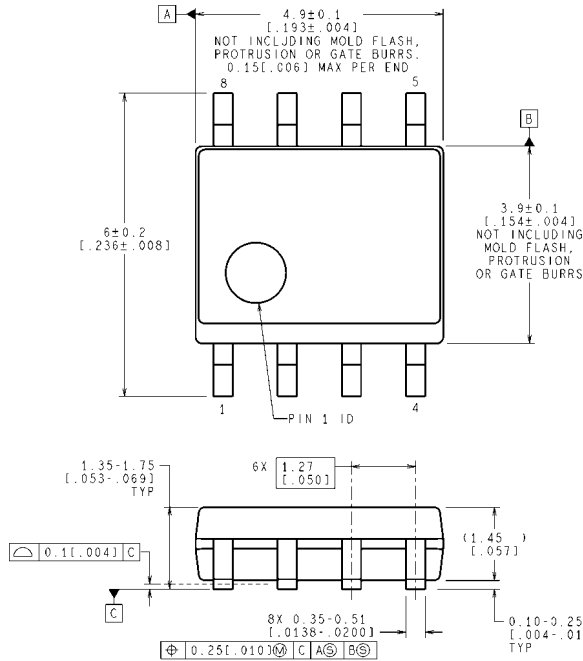

CONTROLLING DIMENSION IS MILLIMETER
VALUES IN [] ARE INCHES
DIMENSIONS IN () FOR REFERENCE ONLY

M08A (Rev M)

**8Pin SOIC
NS Package Number M08A**

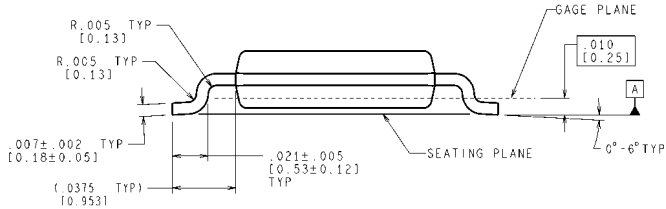
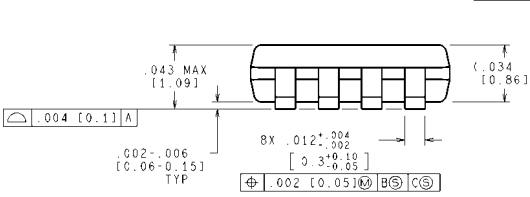
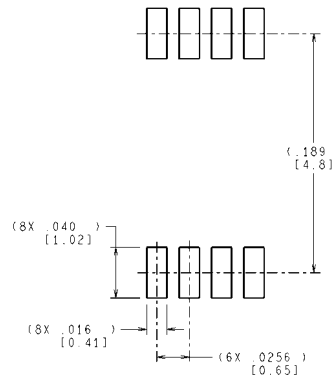
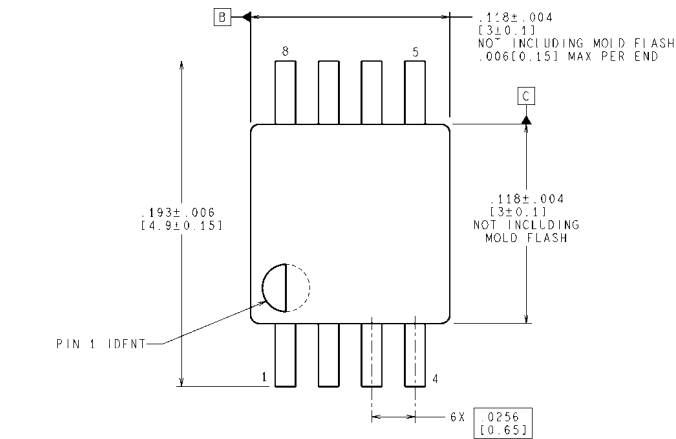

CONTROLLING DIMENSION IS INCH
VALUES IN [] ARE MILLIMETERS

MUA08A (Rev F)

**8Pin MSOP
NS Package Number MUA08A**

Notes

For more National Semiconductor product information and proven design tools, visit the following Web sites at:
www.national.com

Products		Design Support	
Amplifiers	www.national.com/amplifiers	WEBENCH® Tools	www.national.com/webench
Audio	www.national.com/audio	App Notes	www.national.com/appnotes
Clock and Timing	www.national.com/timing	Reference Designs	www.national.com/refdesigns
Data Converters	www.national.com/adc	Samples	www.national.com/samples
Interface	www.national.com/interface	Eval Boards	www.national.com/evalboards
LVDS	www.national.com/lvds	Packaging	www.national.com/packaging
Power Management	www.national.com/power	Green Compliance	www.national.com/quality/green
Switching Regulators	www.national.com/switchers	Distributors	www.national.com/contacts
LDOs	www.national.com/ldo	Quality and Reliability	www.national.com/quality
LED Lighting	www.national.com/led	Feedback/Support	www.national.com/feedback
Voltage References	www.national.com/vref	Design Made Easy	www.national.com/easy
PowerWise® Solutions	www.national.com/powerwise	Applications & Markets	www.national.com/solutions
Serial Digital Interface (SDI)	www.national.com/sdi	Mil/Aero	www.national.com/milaero
Temperature Sensors	www.national.com/tempensors	SolarMagic™	www.national.com/solarmagic
PLL/VCO	www.national.com/wireless	PowerWise® Design University	www.national.com/training

THE CONTENTS OF THIS DOCUMENT ARE PROVIDED IN CONNECTION WITH NATIONAL SEMICONDUCTOR CORPORATION ("NATIONAL") PRODUCTS. NATIONAL MAKES NO REPRESENTATIONS OR WARRANTIES WITH RESPECT TO THE ACCURACY OR COMPLETENESS OF THE CONTENTS OF THIS PUBLICATION AND RESERVES THE RIGHT TO MAKE CHANGES TO SPECIFICATIONS AND PRODUCT DESCRIPTIONS AT ANY TIME WITHOUT NOTICE. NO LICENSE, WHETHER EXPRESS, IMPLIED, ARISING BY ESTOPPEL OR OTHERWISE, TO ANY INTELLECTUAL PROPERTY RIGHTS IS GRANTED BY THIS DOCUMENT.

TESTING AND OTHER QUALITY CONTROLS ARE USED TO THE EXTENT NATIONAL DEEMS NECESSARY TO SUPPORT NATIONAL'S PRODUCT WARRANTY. EXCEPT WHERE MANDATED BY GOVERNMENT REQUIREMENTS, TESTING OF ALL PARAMETERS OF EACH PRODUCT IS NOT NECESSARILY PERFORMED. NATIONAL ASSUMES NO LIABILITY FOR APPLICATIONS ASSISTANCE OR BUYER PRODUCT DESIGN. BUYERS ARE RESPONSIBLE FOR THEIR PRODUCTS AND APPLICATIONS USING NATIONAL COMPONENTS. PRIOR TO USING OR DISTRIBUTING ANY PRODUCTS THAT INCLUDE NATIONAL COMPONENTS, BUYERS SHOULD PROVIDE ADEQUATE DESIGN, TESTING AND OPERATING SAFEGUARDS.

EXCEPT AS PROVIDED IN NATIONAL'S TERMS AND CONDITIONS OF SALE FOR SUCH PRODUCTS, NATIONAL ASSUMES NO LIABILITY WHATSOEVER, AND NATIONAL DISCLAIMS ANY EXPRESS OR IMPLIED WARRANTY RELATING TO THE SALE AND/OR USE OF NATIONAL PRODUCTS INCLUDING LIABILITY OR WARRANTIES RELATING TO FITNESS FOR A PARTICULAR PURPOSE, MERCHANTABILITY, OR INFRINGEMENT OF ANY PATENT, COPYRIGHT OR OTHER INTELLECTUAL PROPERTY RIGHT.

LIFE SUPPORT POLICY

NATIONAL'S PRODUCTS ARE NOT AUTHORIZED FOR USE AS CRITICAL COMPONENTS IN LIFE SUPPORT DEVICES OR SYSTEMS WITHOUT THE EXPRESS PRIOR WRITTEN APPROVAL OF THE CHIEF EXECUTIVE OFFICER AND GENERAL COUNSEL OF NATIONAL SEMICONDUCTOR CORPORATION. As used herein:

Life support devices or systems are devices which (a) are intended for surgical implant into the body, or (b) support or sustain life and whose failure to perform when properly used in accordance with instructions for use provided in the labeling can be reasonably expected to result in a significant injury to the user. A critical component is any component in a life support device or system whose failure to perform can be reasonably expected to cause the failure of the life support device or system or to affect its safety or effectiveness.

National Semiconductor and the National Semiconductor logo are registered trademarks of National Semiconductor Corporation. All other brand or product names may be trademarks or registered trademarks of their respective holders.

Copyright© 2011 National Semiconductor Corporation

For the most current product information visit us at www.national.com



National Semiconductor Americas Technical Support Center
 Email: support@nsc.com
 Tel: 1-800-272-9959

National Semiconductor Europe Technical Support Center
 Email: europe.support@nsc.com

National Semiconductor Asia Pacific Technical Support Center
 Email: ap.support@nsc.com

National Semiconductor Japan Technical Support Center
 Email: jpn.feedback@nsc.com