

# LMH6704

## 650 MHz Selectable Gain Buffer with Disable

### General Description

The LMH™6704 is a very wideband, DC coupled selectable gain buffer designed specifically for wide dynamic range systems requiring exceptional signal fidelity. The LMH6704 includes on chip feedback and gain set resistors, simplifying PCB layout while providing user selectable gains of +1, +2 and -1 V/V. The LMH6704 provides a disable pin, which places the amplifier in a high output impedance, low power mode. The Disable pin may be allowed to float high.

With a 650 MHz Small Signal Bandwidth ( $A_V = +1$ ), full power gain flatness to 200 MHz, and excellent Differential Gain and Phase, the LMH6704 is optimized for video applications. High resolution video systems will benefit from the LMH6704's ability to drive multiple video loads at low levels of differential gain or differential phase distortion.

The LMH6704 is constructed with National's proprietary high speed complementary bipolar process using National's proven current feedback circuit architectures. It is available in 8-Pin SOIC and 6-Pin SOT23 packages.

### Features

- Wideband operation
  - $A_V = +1, V_O = 0.5 V_{PP}$  650 MHz
  - $A_V = +2, V_O = 0.5 V_{PP}$  450 MHz
  - $A_V = +2, V_O = 2 V_{PP}$  400 MHz
- High output current  $\pm 90$  mA
- Very low distortion
  - 2<sup>nd</sup>/3<sup>rd</sup> harmonics (10 MHz,  $R_L = 100\Omega$ ): -62/-78
  - Differential gain/Differential phase: 0.02%/0.02°
- Low noise 2.3nV/√Hz
- High slew rate 3000 V/μs
- Supply current 11.5 mA

### Applications

- HDTV, NTSC & PAL video systems
- Video switching and distribution
- ADC driver
- DAC buffer
- RGB driver
- High speed multiplexer

### Connection Diagram

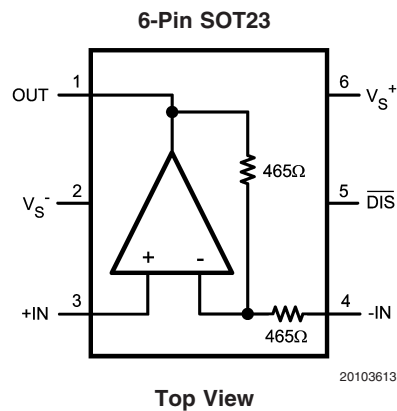
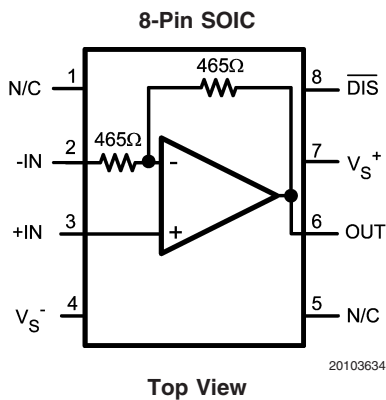

### Ordering Information

Package	Part Number	Package Marking	Transport Media	NSC Drawing
8-Pin SOIC	LMH6704MA	LMH6704MA	95 Units Rail	M08A
	LMH6704MAX		2.5k Units Tape and Reel	
6-Pin SOT23	LMH6704MF	B07A	1k Units Tape and Reel	MF06A
	LMH6704MFX		3k Units Tape and Reel	

LMH™ is a trademark of National Semiconductor Corporation.

**Absolute Maximum Ratings** (Note 1)

If Military/Aerospace specified devices are required, please contact the National Semiconductor Sales Office/Distributors for availability and specifications.

ESD Tolerance (Note 4)	
Human Body Model	2000V
Machine Model	200V
Supply Voltage	13.5V
$I_{OUT}$	(Note 3)
Common-Mode Input Voltage	$V_S^-$ to $V_S^+$
Maximum Junction Temperature	150°C
Storage Temperature Range	-65°C to 150°C

## Soldering Information

Infrared or Convection (20 sec.)	235°C
Wave Soldering (10 sec.)	260°C
Lead Temp. (soldering 10 sec.)	300°C

**Operating Ratings** (Note 1)

Nominal Supply Voltage	±4V to ±6V	
Temperature Range (Note 8)	-40°C to 85°C	
Thermal Resistance		
<b>Package</b>	<b>(<math>\theta_{JC}</math>)</b>	<b>(<math>\theta_{JA}</math>)</b>
8-Pin SOIC	75°C/W	160°C/W
6-Pin SOT23	120°C/W	187°C/W

**Electrical Characteristics** (Note 2)

$T_A = +25^\circ\text{C}$ ,  $A_V = +2$ ,  $V_S = \pm 5\text{V}$ ,  $R_L = 100\Omega$ ; unless specified.

Symbol	Parameter	Conditions	Min (Note 6)	Typ (Note 6)	Max (Note 6)	Units
<b>Dynamic Performance</b>						
SSBW	-3 dB Bandwidth	$V_{OUT} = 0.5 V_{PP}$ , $A_V = +1$		650		MHz
SSBW		$V_{OUT} = 0.5 V_{PP}$		450		
LSBW		$V_{OUT} = 2 V_{PP}$		400		
$GF_{0.1dB}$	0.1 dB Gain Bandwidth	$V_{OUT} = 2 V_{PP}$		200		MHz
SR	Slew Rate	$V_{OUT} = 4 V_{PP}$ , 40% to 60% (Note 5)		3000		V/ $\mu\text{s}$
TRS/TRL	Rise and Fall Time (10% to 90%)	2V Step		0.9		ns
$t_s$	Settling Time to 0.1%	2V Step		10		ns
<b>Distortion and Noise Response</b>						
HD2L	2 <sup>nd</sup> Harmonic Distortion	$V_{OUT} = 2.0 V_{PP}$ , $f = 10\text{ MHz}$		-62		dBc
HD2H		$V_{OUT} = 2.0 V_{PP}$ , $f = 40\text{ MHz}$		-52		
HD3L	3 <sup>rd</sup> Harmonic Distortion	$V_{OUT} = 2.0 V_{PP}$ , $f = 10\text{ MHz}$		-78		dBc
HD3H		$V_{OUT} = 2.0 V_{PP}$ , $f = 40\text{ MHz}$		-65		
IMD	Two-Tone Intermodulation	$f = 10\text{ MHz}$ , $P_{OUT} = 10\text{ dBm/tone}$		-65		dBc
$V_N$	Output Noise Voltage	$f = 100\text{ kHz}$	$A_V = +2$	10.5		nV/ $\sqrt{\text{Hz}}$
			$A_V = +1$	9.3		
			$A_V = -1$	10.5		
$I_{NN}$	Non-Inverting Input Noise Current			3		pA/ $\sqrt{\text{Hz}}$
DG	Differential Gain	$R_L = 150\Omega$ , $f = 4.43\text{ MHz}$		.02		%
DP	Differential Phase	$R_L = 150\Omega$ , $f = 4.43\text{ MHz}$		0.02		deg
<b>Static, DC Performance</b>						
$A_V$	Gain		1.98 <b>1.96</b>	2.00	2.02 <b>2.04</b>	V/V
	Gain Error		-1 <b>-2</b>		+1 <b>+2</b>	%
$V_{IO}$	Input Offset Voltage			2	±7 <b>±8.3</b>	mV
$DV_{IO}$	Input Offset Voltage Average Drift			35		$\mu\text{V}/^\circ\text{C}$
$I_{BN}$	Input Bias Current	Non-Inverting (Note 7)		-5	±15 <b>±18</b>	$\mu\text{A}$
$I_{BI}$	Input Bias Current	Inverting		5	±22 <b>±31</b>	

**Electrical Characteristics** (Note 2) (Continued)
 $T_A = +25^\circ\text{C}$ ,  $A_V = +2$ ,  $V_S = \pm 5\text{V}$ ,  $R_L = 100\Omega$ ; unless specified.

Symbol	Parameter	Conditions	Min (Note 6)	Typ (Note 6)	Max (Note 6)	Units
CMIR	Common Mode Input Range	$V_{IO} \leq 15\text{ mV}$	$\pm 1.9$	$\pm 2$		V
PSRR	Power Supply Rejection Ratio	DC	48 <b>47</b>	52		dB
$V_O$	Output Voltage Swing	$R_L = \infty$	$\pm 3.3$ <b><math>\pm 3.18</math></b>	$\pm 3.5$		V
		$R_L = 100\Omega$	$\pm 3.2$ <b><math>\pm 3.12</math></b>	$\pm 3.5$		
$I_O$	Linear Output Current	$V_{OUT} \leq 80\text{ mV}$	$\pm 55$	$\pm 90$		mA
$I_S$	Supply Current (Enabled)	$\overline{DIS} = 2\text{V}$ , $R_L = \infty$		11.5	12.5 <b>13.7</b>	mA
	Supply Current (Disabled)	$\overline{DIS} = 0.8\text{V}$ , $R_L = \infty$		0.25	0.9 <b>0.925</b>	
$R_F$ & $R_G$	Internal $R_F$ and $R_G$		375	465	563	$\Omega$
$R_{OUT}$	Closed Loop Output Resistance	DC		0.05		$\Omega$
$R_{IN+}$	Input Resistance			1		M $\Omega$
$C_{IN+}$	Input Capacitance			1		pF
<b>Enable/Disable Performance (Disabled Low)</b>						
$T_{ON}$	Enable Time			10		ns
$T_{OFF}$	Disable Time			10		ns
	Output Glitch			50		mV <sub>PP</sub>
$V_{IH}$	Enable Voltage	$\overline{DIS} \geq V_{IH}$	2.0			V
$V_{IL}$	Disable Voltage	$\overline{DIS} \leq V_{IL}$			0.8	
$I_{IH}$	Disable Input Bias Current, High	$\overline{DIS} = V^+$ , (Note 7)		-1	<b><math>\pm 50</math></b>	$\mu\text{A}$
$I_{IL}$	Disable Input Bias Current, Low	$\overline{DIS} = 0\text{V}$ (Note 7)	<b>0</b>	-100	<b>-350</b>	$\mu\text{A}$
$I_{OZ}$	Disabled Output Leakage Current	$A_V = +1$ , $V_{OUT} = \pm 1.8\text{V}$		0.2	$\pm 25$ <b><math>\pm 50</math></b>	$\mu\text{A}$

**Note 1:** Absolute Maximum Ratings indicate limits beyond which damage to the device may occur. Operating Ratings indicate conditions for which the device is intended to be functional, but specific performance is not guaranteed. For guaranteed specifications, see the Electrical Characteristics tables.

**Note 2:** Electrical Table values apply only for factory testing conditions at the temperature indicated. Factory testing conditions result in very limited self-heating of the device such that  $T_J = T_A$ . No guarantee of parametric performance is indicated in the electrical tables under conditions of internal self-heating where  $T_J > T_A$ . Min/Max ratings are based on production testing unless otherwise specified.

**Note 3:** The maximum output current ( $I_{OUT}$ ) is determined by device power dissipation limitations.

**Note 4:** Human Body Model, applicable std. MIL-STD-883, Method 3015.7. Machine Model, applicable std. JESD22-A115-A (ESD MM std. of JEDEC)

Field-Induced Charge-Device Model, applicable std. JESD22-C101-C (ESD FICDM std. of JEDEC).

**Note 5:** Slew Rate is the average of the rising and falling edges.

**Note 6:** Typical values represent the most likely parametric norm as determined at the time of characterization. Actual typical values may vary over time and will also depend on the application and configuration. The typical values are not tested and are not guaranteed on shipped production material.

**Note 7:** Negative current implies current flowing out of the device.

**Note 8:** The maximum power dissipation is a function of  $T_{J(MAX)}$ ,  $\theta_{JA}$ . The maximum allowable power dissipation at any ambient temperature is  $P_D = (T_{J(MAX)} - T_A) / \theta_{JA}$ . All numbers apply for packages soldered directly onto a PC Board.

**Typical Performance Characteristics** ( $T_A = 25^\circ\text{C}$ ,  $V_S = \pm 5\text{V}$ ,  $R_L = 100\Omega$ ,  $A_V = +2$ ,  $V_{OUT} = 0.5 V_{PP}$ ; Unless Specified).

**Small Signal Frequency Response vs. Gain**

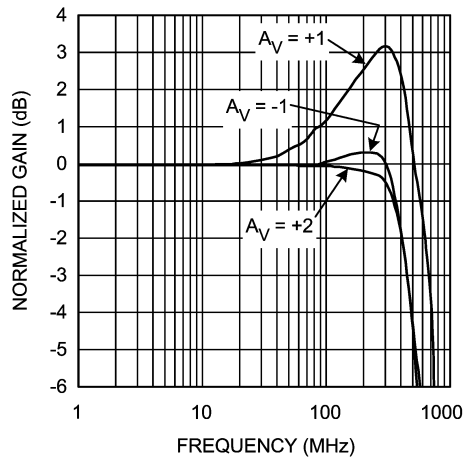

20103614

**Frequency Response vs.  $V_{OUT}$**

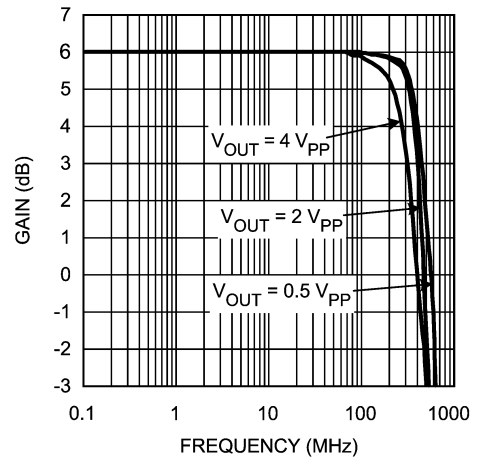

20103615

**Small Signal Frequency Response vs.  $R_{LOAD}$**

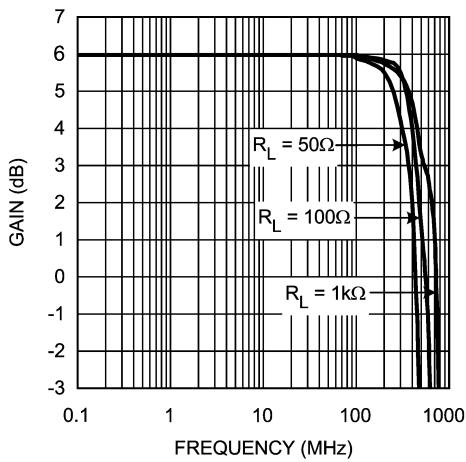

20103616

**Large Signal Gain Flatness**

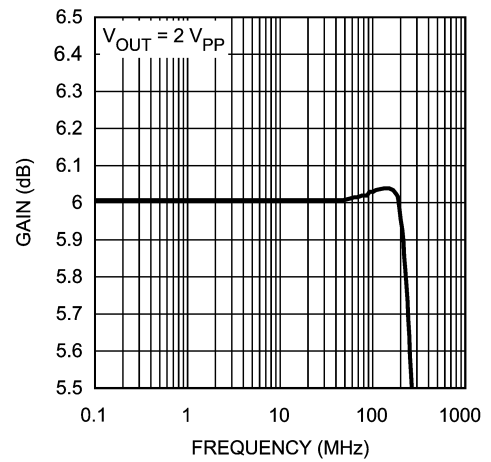

20103617

**Small Signal Frequency Response vs. Capacitive Load**

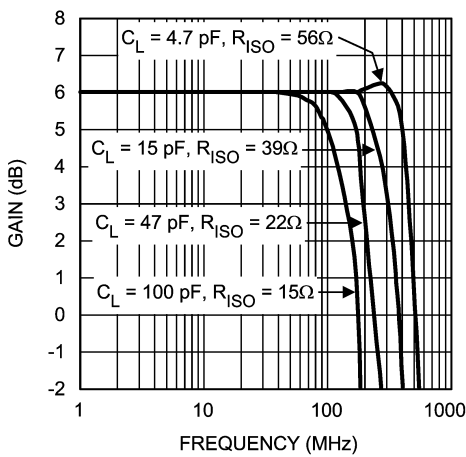

20103618

**Series Output Isolation Resistance vs. Capacitive Load**

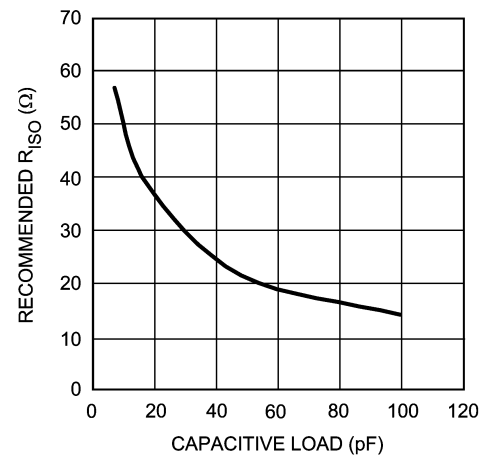

20103619

**Typical Performance Characteristics** ( $T_A = 25^\circ\text{C}$ ,  $V_S = \pm 5\text{V}$ ,  $R_L = 100\Omega$ ,  $A_V = +2$ ,  $V_{OUT} = 0.5 V_{PP}$ ; Unless Specified). (Continued)

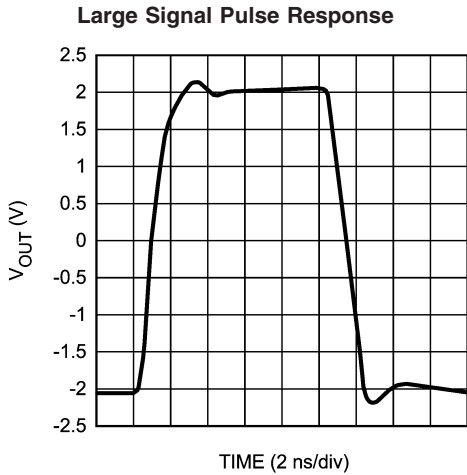

20103620

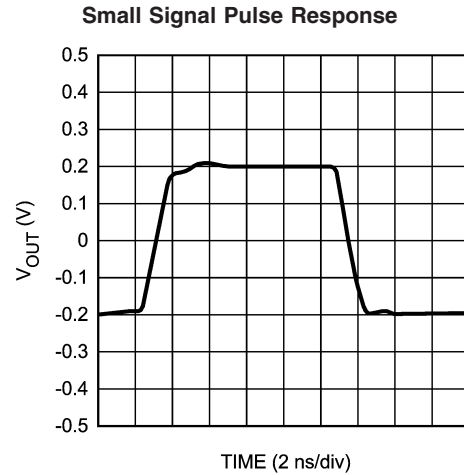

20103621

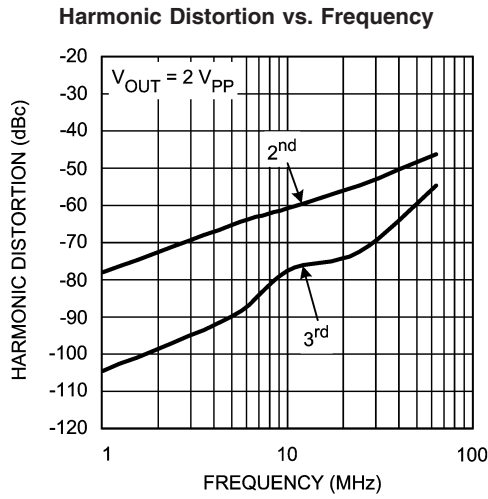

20103622

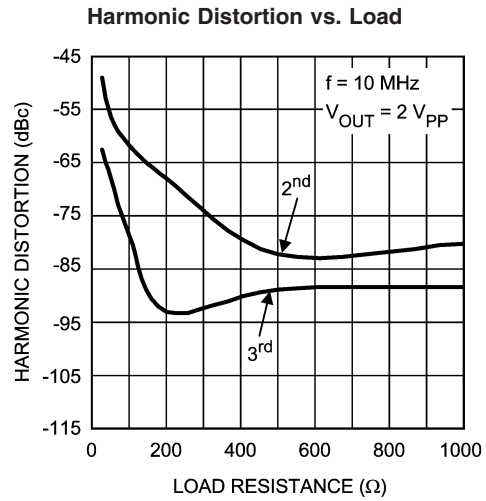

20103623

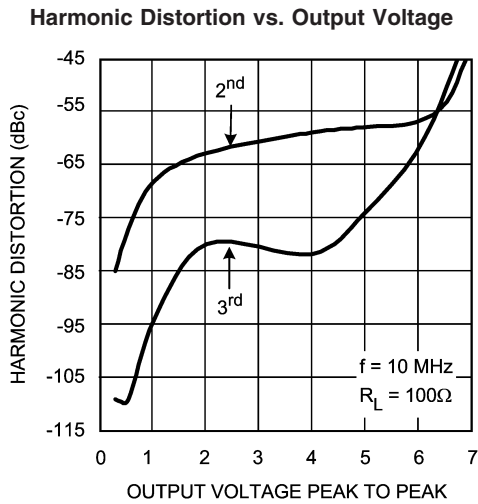

20103624

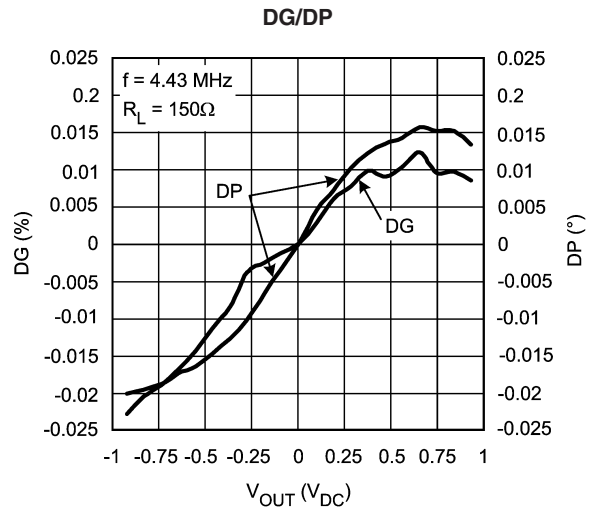

20103633

**Typical Performance Characteristics** ( $T_A = 25^\circ\text{C}$ ,  $V_S = \pm 5\text{V}$ ,  $R_L = 100\Omega$ ,  $A_V = +2$ ,  $V_{OUT} = 0.5 V_{PP}$ ; Unless Specified). (Continued)

**PSRR vs. Frequency**

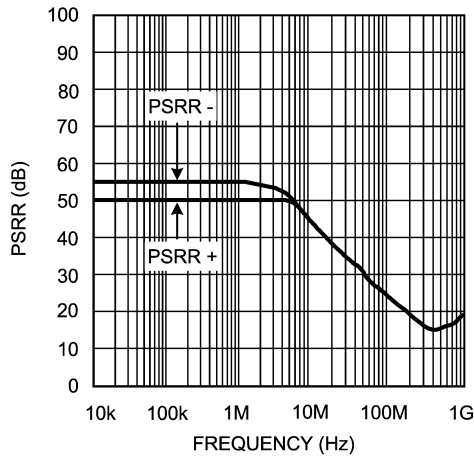

20103628

**DC Errors vs. Temperature (A Typical Unit, (Note 7))**

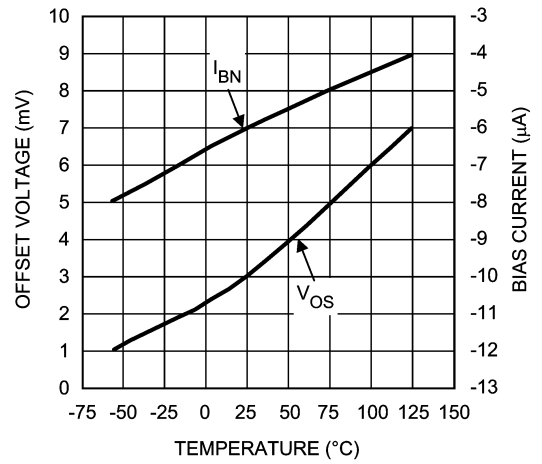

20103629

**Disable Timing**

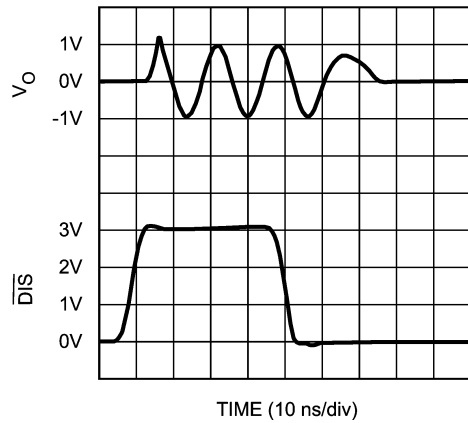

20103630

**Disable Output Glitch**

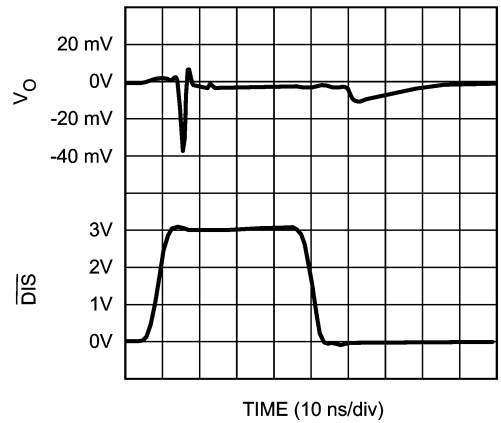

20103631

# Application Information

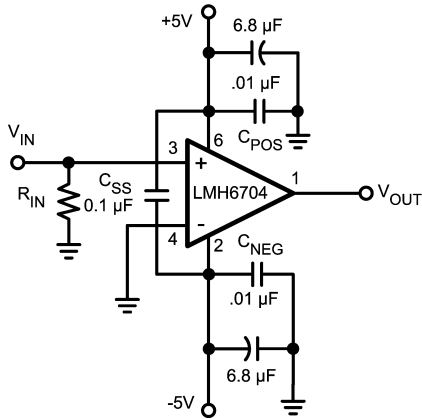

20103603

FIGURE 1. Recommended Gain of +2 Circuit

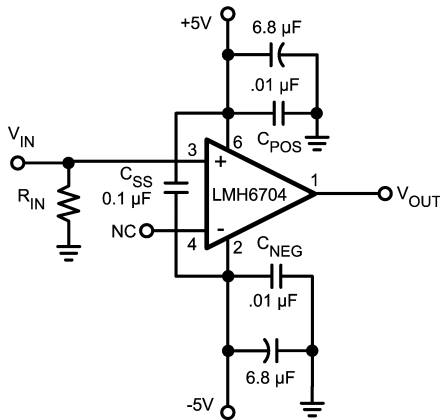

20103604

FIGURE 2. Recommended Gain of +1 Circuit

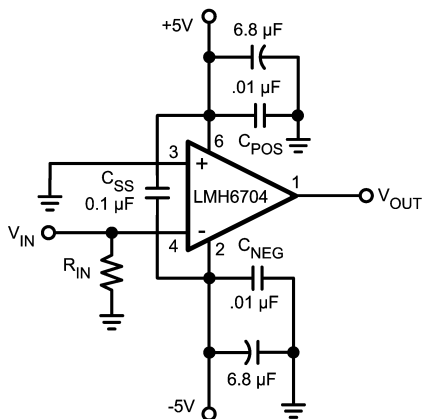

20103605

FIGURE 3. Recommended Gain of -1 Circuit

## GENERAL INFORMATION

The LMH6704 is a high speed current feedback Selectable Gain Buffer (SGB), optimized for very high speed and low distortion. With its internal feedback and gain-setting resistors the LMH6704 offers excellent AC performance while simplifying board layout and minimizing the affects of layout related parasitic components. The LMH6704 has no internal ground reference so single or split supply configurations are both equally useful.

## SETTING THE CLOSED LOOP GAIN

The LMH6704 is a current feedback amplifier with on-chip  $R_F = R_G = 465\Omega$ . As such it can be configured with an  $A_V = +2$ ,  $A_V = +1$ , or an  $A_V = -1$  by connecting pins 3 and 4 as described in the chart below.

GAIN $A_V$	Input Connections	
	Non-Inverting (Pin 3)	Inverting (Pin 4)
-1 V/V	Ground	Input Signal
+1 V/V	Input Signal	NC (Open)
+2 V/V	Input Signal	Ground

The gain accuracy of the LMH6704 is accurate and guaranteed over temperature to within  $\pm 1\%$ . The internal gain setting resistors,  $R_F$  and  $R_G$ , match very well. The LMH6704 architecture takes advantage of the fact that the internal gain setting resistors track each other well over a wide range of temperature and process variation to keep the overall gain constant, despite the fact that the individual resistors have nominal temperature drifts. Therefore, using external resistors in series with  $R_G$  to change the gain will result in poor gain accuracy over temperature.

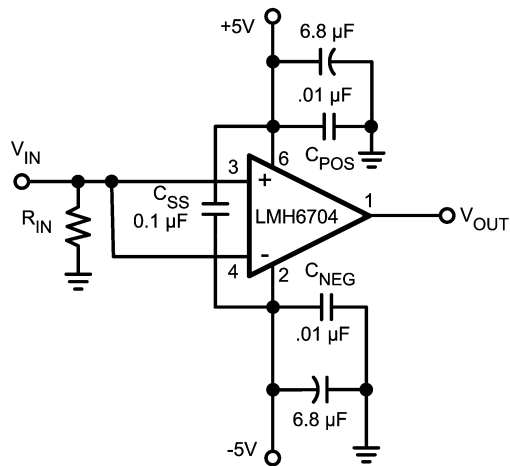

20103609

FIGURE 4. Alternate Unity Gain Configuration

# Application Information (Continued)

## UNITY GAIN COMPENSATION

With a current feedback Selectable Gain Buffer like the LMH6704, the feedback resistor is a compromise between the value needed for stability at unity gain and the optimized value needed at a gain of two. In standard open-loop current feedback operational amplifiers the feedback resistor,  $R_F$ , is external and its value can be adjusted to match the required gain. Since the feedback resistor is integrated in the LMH6704, it is not possible to adjust its value. However, we can employ the circuit shown in *Figure 4*. This circuit modifies the noise gain of the amplifier to eliminate the peaking associated with using the circuit shown in *Figure 2*. The frequency response is shown in *Figure 5*. The decreased peaking does come at a price as the output referred voltage noise density increases by a factor of 1.1.

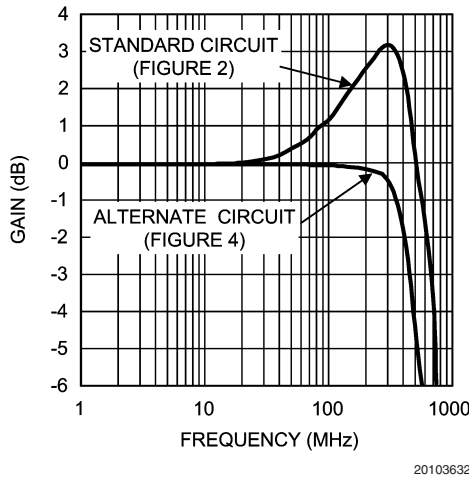

FIGURE 5. Unity Gain Frequency Response

## OUTPUT VOLTAGE NOISE

Open-loop operational amplifiers specify three input referred noise parameters: input voltage noise, non-inverting input current noise, and inverting input current noise. These specifications are used to calculate the total voltage noise produced at the output of the amplifier. The LMH6704 is a closed loop amplifier with internal resistors, thus only the non-inverting input current noise flows through external components. All other noise sources are internal to the part. There are four possible values for the noise at the output depending on the gain configuration as shown in *Table 1*. For more information on calculating noise in current feedback amplifiers see Application Notes OA-12 and AN104 available at [www.national.com](http://www.national.com).

The total noise voltage at the output can be calculated using the following formula:

$$E_o = \sqrt{(4kTR_{SOURCE} + (I_{BN} \cdot R_{SOURCE})^2) \cdot G_N^2 + (OUTPUT REFERRED NOISE VOLTAGE)^2}$$

Where  $G_N$  = Noise Gain and  $4kT = 16E-21$  Joules @ Room Temperature

For example, if an  $A_V = +2$  configuration is used with a source impedance of  $37.5\Omega$  (parallel combination of  $75\Omega$  source and  $75\Omega$  termination impedances), where " $I_{BN}$ " is  $18.5pA/\sqrt{Hz}$  and the output referred voltage noise (excluding non-inverting input noise current) can be found in *Table 1* below. The total noise ( $E_o$ ) at the output can be calculated as:

$$E_o = \sqrt{(16E-21 \cdot 37.5 + (18.5 pA \cdot 37.5)^2) \cdot 2^2 + (10.5 nV)^2} = 10.6 nV/\sqrt{Hz}$$

TABLE 1. Measured Output Noise Voltage

Gain ( $A_V$ )	Output Referred Voltage Noise (nV/√Hz), excluding non-inverting noise current
+2	10.5
+1	9.3
+1, alternate method shown in <i>Figure 4</i>	10.5
-1	10.5

Note:  $f \geq 100$  kHz

## ENABLE/DISABLE

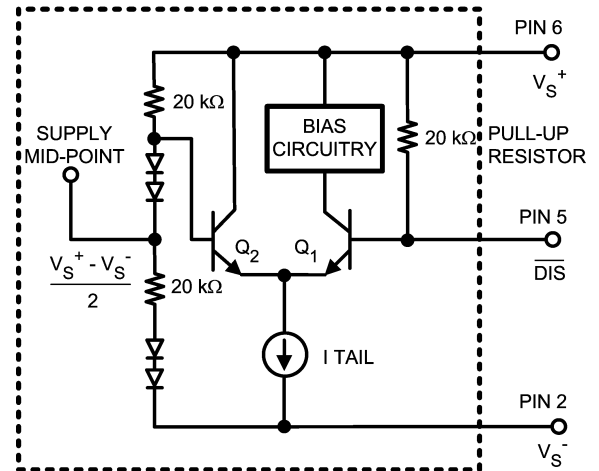

NOTE: PINS 2, 5, 6 ARE EXTERNAL

20103612

FIGURE 6. DIS Pin Simplified Schematic

The LMH6704 has a TTL logic compatible disable function. Apply a logic low (<.8V) to the DS pin and the LMH6704 is disabled. Apply a logic high (>2.0V), or let the pin float and the LMH6704 is enabled. Voltage, not current, at the Disable pin (DS) determines the enable/disable state. Care must be exercised to prevent the disable pin voltage from going more than .8V below the midpoint of the supply voltages (0V with split supplies,  $V^+/2$  with single supply biasing). Doing so could cause transistor Q1 to Zener resulting in damage to the disable circuit (See *Figure 6* or the simplified internal schematic diagram). The core amplifier is unaffected by this, but the disable operation could become permanently slower as a result.

Disabled, the LMH6704 inputs and output become high impedances. While disabled the LMH6704 quiescent current is



## Application Information (Continued)

approximately 250  $\mu\text{A}$ . Because of the pull up resistor on the disable circuit, the  $I_{\text{CC}}$  and  $I_{\text{EE}}$  currents (positive and negative supply currents respectively) are not balanced in the disabled state. The positive supply current ( $I_{\text{CC}}$ ) is approximately 350  $\mu\text{A}$  while the negative supply current ( $I_{\text{EE}}$ ) is only 250  $\mu\text{A}$ . The remaining  $I_{\text{EE}}$  current of 100  $\mu\text{A}$  flows through the disable pin.

The disable function can be used to create analog switches or multiplexers. Implement a single analog switch with one LMH6704 positioned between an input and output. Create an analog multiplexer with several LMH6704's. Use the circuit shown in for multiplexer applications because there is no RG to shunt signals to ground.

### EVALUATION BOARDS

National Semiconductor provides the following evaluation boards as a guide for high frequency layout and as an aid in device testing and characterization. Many of the datasheet plots were measured with these boards.

Device	Package	Evaluation Board Part Number
LMH6704MA	SOIC-8	CLC730227
LMH6704MF	SOT23-6	CLC730216

An evaluation board is shipped upon request when a sample order is placed with National Semiconductor.

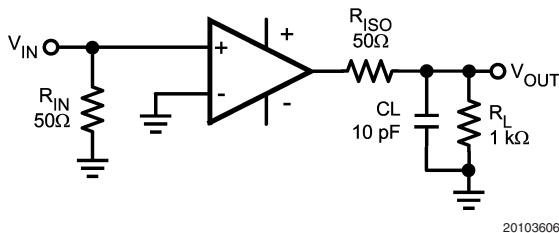

FIGURE 7. Decoupling Capacitive Loads

### DRIVING CAPACITIVE LOADS

Capacitive output loading applications will benefit from the use of a series output resistor  $R_{\text{ISO}}$ . Figure 7 shows the use of a series output resistor,  $R_{\text{ISO}}$ , to stabilize the amplifier output under capacitive loading. Capacitive loads of 5 to 120 pF are the most critical, causing ringing, frequency response peaking and possible oscillation. The chart "Suggested  $R_{\text{ISO}}$  vs. Cap Load" gives a recommended value for selecting a series output resistor for mitigating capacitive loads. The values suggested in the charts are selected for .5 dB or less of peaking in the frequency response. This gives a good compromise between settling time and bandwidth. For applications where maximum frequency response is needed and some peaking is tolerable, the value of  $R_{\text{ISO}}$  can be reduced slightly from the recommended values.

### LAYOUT CONSIDERATIONS

Whenever questions about layout arise, use the evaluation board as a guide. The CLC730216 is the evaluation board supplied with samples of the LMH6704. To reduce parasitic capacitances ground and power planes should be removed near the input and output pins. For long signal paths controlled impedance lines should be used, along with imped-

ance matching elements at both ends. Bypass capacitors should be placed as close to the device as possible. Bypass capacitors from each rail to ground are applied in pairs. The larger electrolytic bypass capacitors can be located farther from the device, the smaller ceramic capacitors should be placed as close to the device as possible. In Figure 1, Figure 2, and Figure 3  $C_{\text{SS}}$  is optional, but is recommended for best second order harmonic distortion. Another option to using  $C_{\text{SS}}$  is to use pairs of 0.01  $\mu\text{F}$  and 0.1  $\mu\text{F}$  ceramic capacitors for each supply bypass.

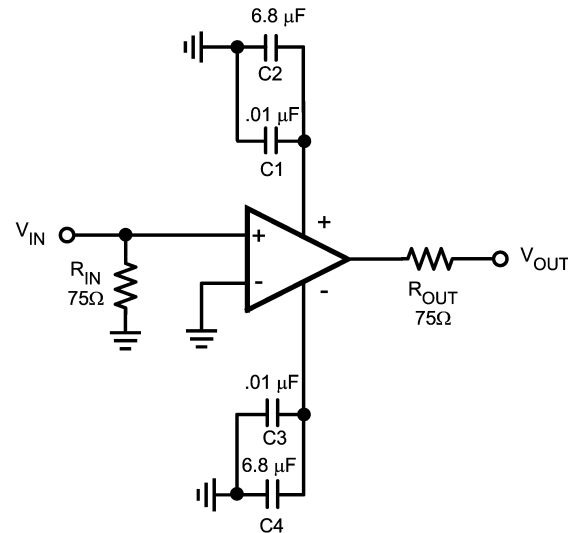

FIGURE 8. Typical Video Application

### VIDEO PERFORMANCE

The LMH6704 has been designed to provide excellent performance with production quality video signals in a wide variety of formats such as HDTV and High Resolution VGA. NTSC and PAL performance is nearly flawless with DG of 0.02% and DP of 0.02°. Best performance will be obtained with back terminated loads. The back termination reduces reflections from the transmission line and effectively masks transmission line and other parasitic capacitances from the amplifier output stage. Figure 8 shows a typical configuration for driving a 75 $\Omega$  Cable. The amplifier is configured for a gain of two to make up for the 6 dB of loss in  $R_{\text{OUT}}$ .

### POWER DISSIPATION

Follow these steps to determine the Maximum power dissipation for the LMH6704:

1. Calculate the quiescent (no-load) power:  

$$P_{\text{AMP}} = I_{\text{CC}} \cdot (V_{\text{S}})$$
, where  $V_{\text{S}} = V^{+} - V^{-}$
2. Calculate the RMS power dissipated in the output stage:  

$$P_{\text{D}} (\text{rms}) = \text{rms} ((V_{\text{S}} - V_{\text{OUT}}) \cdot I_{\text{OUT}})$$
, where  $V_{\text{OUT}}$  and  $I_{\text{OUT}}$  are the voltage and current across the external load and  $V_{\text{S}}$  is the total supply current
3. Calculate the total RMS power:  $P_{\text{T}} = P_{\text{AMP}} + P_{\text{D}}$

The maximum power that the LMH6704, package can dissipate at a given temperature can be derived with the following equation:

## Application Information (Continued)

$P_{MAX} = (150^\circ - T_{AMB}) / \theta_{JA}$ , where  $T_{AMB}$  = Ambient temperature ( $^\circ\text{C}$ ) and  $\theta_{JA}$  = Thermal resistance, from junction to ambient, for a given package ( $^\circ\text{C}/\text{W}$ ). For the SOT23-6 package  $\theta_{JA}$  is  $187^\circ\text{C}/\text{W}$ .

### ESD PROTECTION

The LMH6704 is protected against electrostatic discharge (ESD) on all pins. The LMH6704 will survive 2000V Human Body model and 200V Machine model events. Input and Output pins have ESD diodes to either supply pin ( $V^+$  and

$V^-$ ) which are reverse biased and essentially have no effect under most normal operating conditions. There are occasions, however, when the ESD diodes will be evident. If the LMH6704 is driven by a large signal while the device is powered down, the ESD diodes might enter forward operating region and conduct. The current that flows through the ESD diodes will either exit the chip through the supply pins or will flow through the device, hence it is possible to inadvertently power up the LMH6704 with a large signal applied to the input pins. Shorting the power pins to each other will prevent the chip from being powered up through the input.

**Physical Dimensions** inches (millimeters)

unless otherwise noted

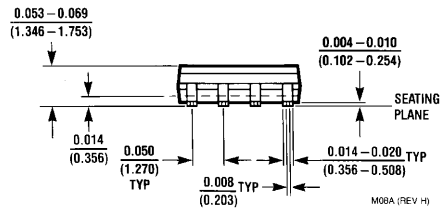
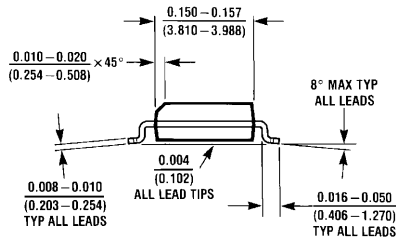
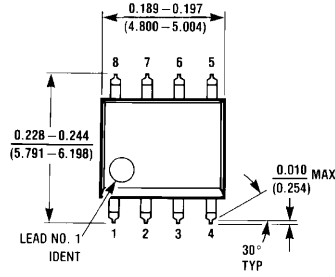

**8-Pin SOIC**  
**NS Package Number M08A**

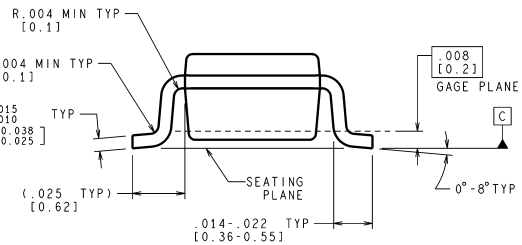
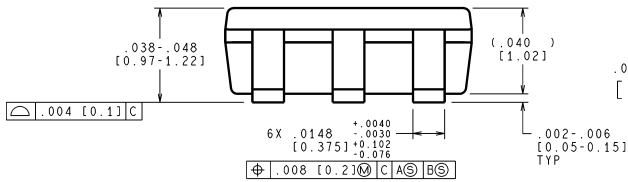
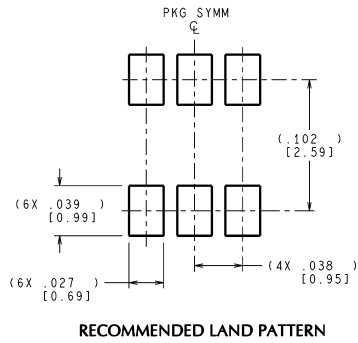
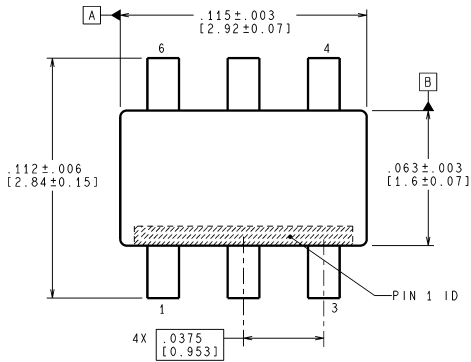

CONTROLLING DIMENSION IS INCH  
VALUES IN [ ] ARE MILLIMETERS  
DIMENSIONS IN ( ) FOR REFERENCE ONLY

**6-Pin SOT23**  
**NS Package Number MF06A**

MF06A (Rev C)

## Notes

National does not assume any responsibility for use of any circuitry described, no circuit patent licenses are implied and National reserves the right at any time without notice to change said circuitry and specifications.

For the most current product information visit us at [www.national.com](http://www.national.com).

### LIFE SUPPORT POLICY

NATIONAL'S PRODUCTS ARE NOT AUTHORIZED FOR USE AS CRITICAL COMPONENTS IN LIFE SUPPORT DEVICES OR SYSTEMS WITHOUT THE EXPRESS WRITTEN APPROVAL OF THE PRESIDENT AND GENERAL COUNSEL OF NATIONAL SEMICONDUCTOR CORPORATION. As used herein:

1. Life support devices or systems are devices or systems which, (a) are intended for surgical implant into the body, or (b) support or sustain life, and whose failure to perform when properly used in accordance with instructions for use provided in the labeling, can be reasonably expected to result in a significant injury to the user.
2. A critical component is any component of a life support device or system whose failure to perform can be reasonably expected to cause the failure of the life support device or system, or to affect its safety or effectiveness.

### BANNED SUBSTANCE COMPLIANCE

National Semiconductor follows the provisions of the Product Stewardship Guide for Customers (CSP-9-111C2) and Banned Substances and Materials of Interest Specification (CSP-9-111S2) for regulatory environmental compliance. Details may be found at: [www.national.com/quality/green](http://www.national.com/quality/green).

Lead free products are RoHS compliant.



**National Semiconductor**  
Americas Customer  
Support Center  
Email: [new.feedback@nsc.com](mailto:new.feedback@nsc.com)  
Tel: 1-800-272-9959

[www.national.com](http://www.national.com)

**National Semiconductor**  
Europe Customer Support Center  
Fax: +49 (0) 180-530 85 86  
Email: [europa.support@nsc.com](mailto:europa.support@nsc.com)  
Deutsch Tel: +49 (0) 69 9508 6208  
English Tel: +44 (0) 870 24 0 2171  
Français Tel: +33 (0) 1 41 91 8790

**National Semiconductor**  
Asia Pacific Customer  
Support Center  
Email: [ap.support@nsc.com](mailto:ap.support@nsc.com)

**National Semiconductor**  
Japan Customer Support Center  
Fax: 81-3-5639-7507  
Email: [jpn.feedback@nsc.com](mailto:jpn.feedback@nsc.com)  
Tel: 81-3-5639-7560