

LME49726

High Current, Low Distortion, Rail-to-Rail Output Audio Operational Amplifier

General Description

The LME49726 is a low distortion, low noise rail-to-rail output audio operational amplifier optimized and fully specified for high performance, high fidelity applications. The LME49726 delivers superior audio signal amplification for outstanding audio performance. The LME49726 has a very low THD+N to easily satisfy demanding audio applications. To ensure that the most challenging loads are driven without compromise, the LME49726 provides output current greater than 300mA at 5V. Further, dynamic range is maximized by an output stage that drives 2kΩ loads to within 4mV of either power supply voltage.

The LME49726 has a supply range of 2.5V to 5.5V. Over this supply range the LME49726's input circuitry maintains excellent common-mode and power supply rejection, as well as maintaining its low input bias current. The LME49726 is unity gain stable.

Key Specifications

- Power Supply Voltage Range 2.5V to 5.5V
- Quiescent Current per Amplifier at 5V 0.7mA (typ)
- THD+N, $A_V = 1$,
 $f_{IN} = 1\text{kHz}$, $R_L = 10\text{k}\Omega$
($V_{OUT} = 3.5V_{P-P}$, $V_{DD} = 5.0V$) 0.00008% (typ)
($V_{OUT} = 1.5V_{P-P}$, $V_{DD} = 2.5V$) 0.00002% (typ)
- Equivalent Input Noise
($f = 10\text{k}$, A-weighted) 6.9nV/ $\sqrt{\text{Hz}}$ (typ)

- Slew Rate $\pm 3.7V/\mu\text{s}$ (typ)
- Gain Bandwidth Product 6.25MHz (typ)
- Open Loop Gain ($R_L = 10\text{k}\Omega$) 120dB (typ)
- Input Bias Current 0.2pA (typ)
- Input Offset Voltage 0.5mV (typ)
- PSRR (DC) 104dB (typ)

Features

- Rail-to-rail output
- Easily drives 2kΩ loads to within 4mV of each power supply voltage rail
- Optimized for superior audio signal fidelity
- Output short circuit protection
- High output drive (>300mA)
- Available in mini-SOIC exposed-DAP package

Applications

- Portable audio amplification
- Preamplifiers and multimedia
- Equalization and crossover networks
- Line drivers and receivers
- Active filters
- DAC I-V converter gain stage
- ADC front-end signal conditioning

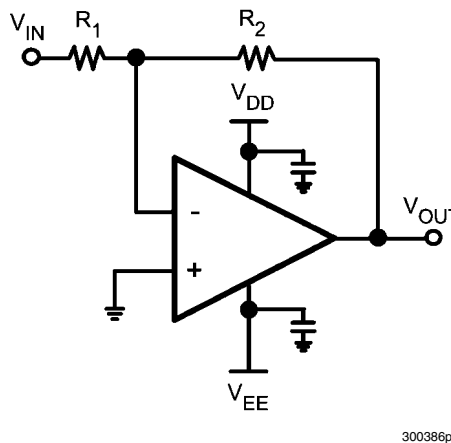

FIGURE 1. Inverting Configuration Split Supplies

LME49726 High Current, Low Distortion, Rail-to-Rail Output Audio Operational Amplifier

Typical Connection, Pinout, and Package Marking

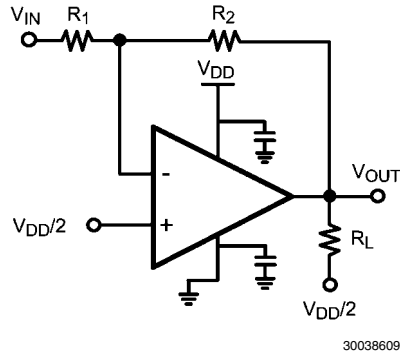
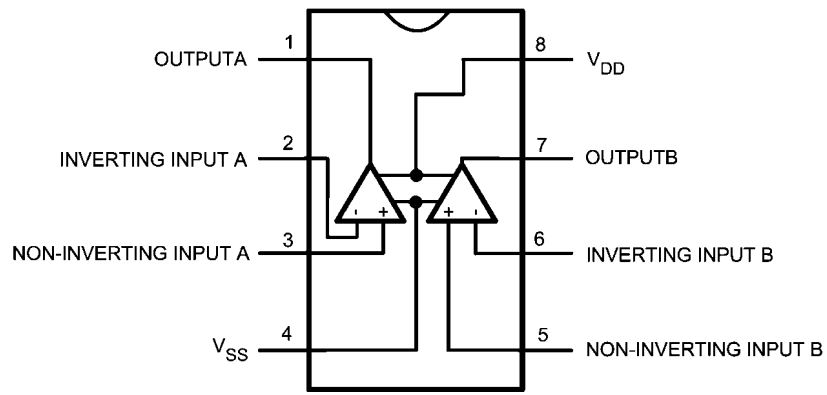
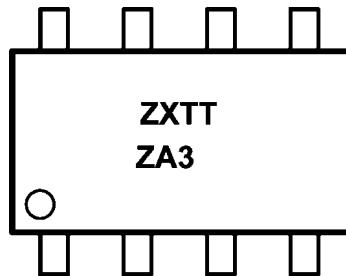

FIGURE 2. Inverting Configuration Single Supply



Order Number LME49726MY
See NS Package Number MUY08A

Package Marking



Z = Assembly plant code
X = 1 Digit date code
TT = Lot traceability
ZA3 = LME49726

Ordering Information

Order Number	Package	Package Drawing Number	Transport Media	MSL Level	Green Status
LME49726MY	MSOP EXPOSE PAD	MUY08A	1000 units on tape on reel	1	RoHS & no Sb/Br
LME49726MYX	MSOP EXPOSE PAD	MUY08A	3500 units on tape on reel	1	RoHS & no Sb/Br

Absolute Maximum Ratings (Note 1, Note 2)

If Military/Aerospace specified devices are required, please contact the National Semiconductor Sales Office/Distributors for availability and specifications.

Power Supply Voltage	$V_S = V_{SS} - V_{DD}$	6V
Storage Temperature		-65°C to 150°C
Input Voltage		$(V_{SS}) - 0.7V$ to $(V_{DD}) + 0.7V$
Output Short Circuit (Note 3)		Continuous
Power Dissipation		Internally Limited

ESD Rating (Note 4)	2000V
ESD Rating (Note 5)	200V
Junction Temperature	150°C
Thermal Resistance	
θ_{JA} (MUY-08)	72°C/W

Operating Ratings (Note 1)

Temperature Range	$T_{MIN} \leq T_A \leq T_{MAX}$	-40°C ≤ T_A ≤ 125°C
Supply Voltage Range		$2.5V \leq V_S \leq 5.5V$

Electrical Characteristics ($V_{DD} = 5.0V$ and $V_{DD} = 2.5V$) The following specifications apply for the circuit shown in Figure 1. $V_{DD} = 5.0V$ and $V_{DD} = 2.5V$, $V_{SS} = 0.0V$, $V_{CM} = V_{DD}/2$, $R_L = 10k\Omega$, $C_{LOAD} = 20pF$, $f_{IN} = 1kHz$, $BW = 20-20kHz$, and $T_A = 25^\circ C$, unless otherwise specified.

Symbol	Parameter	Conditions	LME49726		Units (Limits)
			Typical	Limit	
			(Note 6)	(Note 7)	
THD+N	Total Harmonic Distortion + Noise	$A_V = -1$, $V_{OUT} = 3.5V_{p-p}$, $V_{DD} = 5V$			
		$R_L = 600\Omega$	0.0008		%
		$R_L = 2k\Omega$	0.0002		%
		$R_L = 10k\Omega$	0.00008		%
		$A_V = -1$, $V_{OUT} = 1.5V_{p-p}$, $V_{DD} = 2.5V$			
		$R_L = 600\Omega$	0.001		%
		$R_L = 2k\Omega$	0.0008		%
		$R_L = 10k\Omega$	0.0002		%
GBWP	Gain Bandwidth Product		6.25	5.0	MHz (min)
SR	Slew Rate	$A_V = +1$, $R_L = 10k\Omega$	3.7	2.5	V/ μs (min)
t_s	Settling time	$A_V = 1V$ step			
		0.1% error range	800		ns
		0.001% error range	1.2		μs
e_N	Equivalent Input Noise Voltage	$f_{BW} = 20Hz$ to $20kHz$ (A-weighted)	0.7	1.25	μV_{RMS} (max)
e_N	Equivalent Input Noise Density	$f = 10kHz$ (A-weighted)	6.9		nV/\sqrt{Hz}
		$f = 1kHz$ (A-weighted)	15		nV/\sqrt{Hz}
		$f = 100Hz$ (A-weighted)	35		nV/\sqrt{Hz}
I_N	Current Noise Density	$f = 1kHz$	0.75		pA/\sqrt{Hz}
V_{OS}	Input Offset Voltage	$V_{IN} = V_{DD}/2$, $V_O = V_{DD}/2$, $A_V = 1$	0.5	2.25	mV (max)
$\Delta V_{OS}/\Delta Temp$	Average Input Offset Voltage Drift vs Temperature	$40^\circ C \leq T_A \leq 85^\circ C$	1.2		$\mu V/^\circ C$
PSRR	Power Supply Rejection Ratio	2.5 to $5.5V$, $V_{CM} = 0$, $V_{DD}/2$	104	85	dB (min)
ISO _{CH-CH}	Channel-to-Channel Isolation	$f_{IN} = 1kHz$	94		dB
I_B	Input Bias Current	$V_{CM} = V_{DD}/2$	±0.2		pA
$\Delta I_{OS}/\Delta Temp$	Input Bias Current Drift vs Temperature	$-40^\circ C \leq T_A \leq 85^\circ C$	35		nA/°C
I_{OS}	Input Offset Current	$V_{CM} = V_{DD}/2$	±0.2		pA
V_{IN-CM}	Common-Mode Input Voltage Range			$V_{DD} - 1.6$ $V_{SS} + 0.1$	V (min)
CMRR	Common Mode Rejection Ratio	$0.1V < V_{DD} - 1.6V$	95	80	dB (min)
1/f	1/f Corner Frequency		2		kHz
A_{VOL}	Open-Loop Voltage Gain	$V_{OUT} = V_{DD}/2$	120	100	dB (min)

Symbol	Parameter	Conditions	LME49726		Units (Limits)
			Typical	Limit	
			(Note 6)	(Note 7)	
V _{OUTSWING}	Maximum Output Voltage Swing	R _L = 2kΩ to V _{DD} /2	V _{DD} -0.004 V _{SS} +0.004		V (min) V (max)
		R _L = 16Ω to V _{DD} /2	V _{DD} -0.33 V _{SS} +0.33		V (min) V (max)
I _{OUT}	Output Current	V _{OUT} = 5V, V _{DD} = 5V	350		mA
		V _{OUT} = 2.5V, V _{DD} = 2.5V	160		mA
I _S	Quiescent Current per Amplifier	I _{OUT} = 0mA, V _{DD} = 5V	0.7	1.1	mA (max)
		I _{OUT} = 0mA, V _{DD} = 2.5V	0.64	1.0	mA (max)

Note 1: *Absolute Maximum Ratings* indicate limits beyond which damage to the device may occur, including inoperability and degradation of device reliability and/or performance. Functional operation of the device and/or non-degradation at the *Absolute Maximum Ratings* or other conditions beyond those indicated in the *Recommended Operating Conditions* is not implied. The *Recommended Operating Conditions* indicate conditions at which the device is functional and the device should not be operated beyond such conditions. All voltages are measured with respect to the ground pin, unless otherwise specified.

Note 2: The *Electrical Characteristics* tables list guaranteed specifications under the listed *Recommended Operating Conditions* except as otherwise modified or specified by the *Electrical Characteristics Conditions* and/or Notes. Typical specifications are estimations only and are not guaranteed.

Note 3: The maximum power dissipation must be derated at elevated temperatures and is dictated by T_{JMAX} , θ_{JA} , and the ambient temperature, T_A . The maximum allowable power dissipation is $P_{DMAX} = (T_{JMAX} - T_A) / \theta_{JA}$ or the number given in *Absolute Maximum Ratings*, whichever is lower. For the LME49726, see Power Derating curve for additional information.

Note 4: Human body model, applicable std. JESD22-A114C.

Note 5: Machine model, applicable std. JESD22-A115-A.

Note 6: Typical values represent most likely parametric norms at $T_A = +25^\circ\text{C}$, and at the *Recommended Operation Conditions* at the time of product characterization and are not guaranteed.

Note 7: Datasheet min/max specification limits are guaranteed by test or statistical analysis.

Typical Performance Characteristics

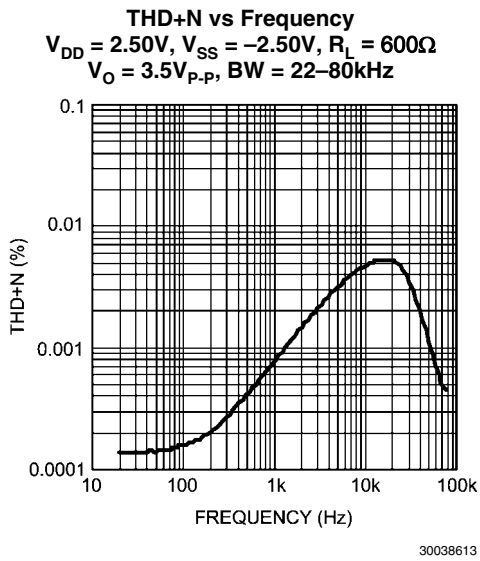
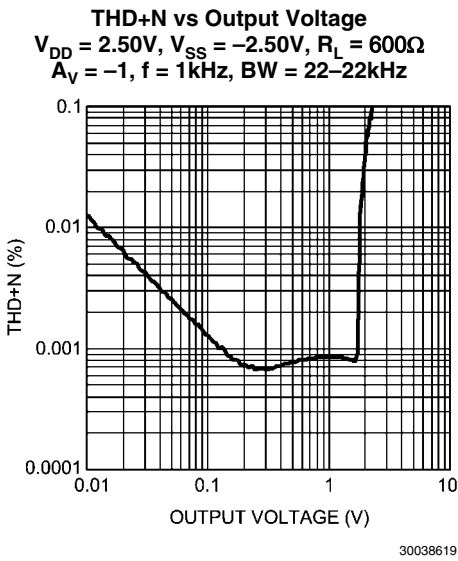
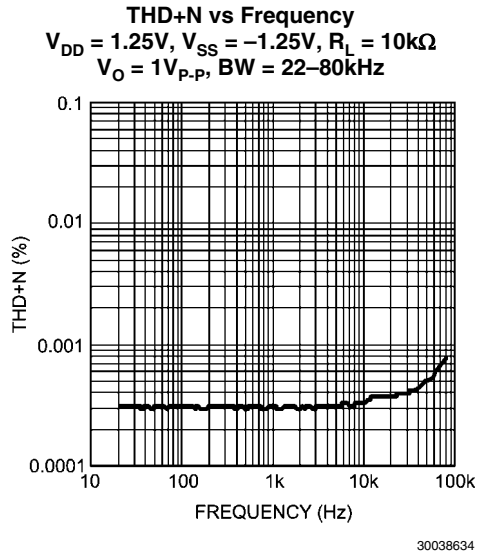
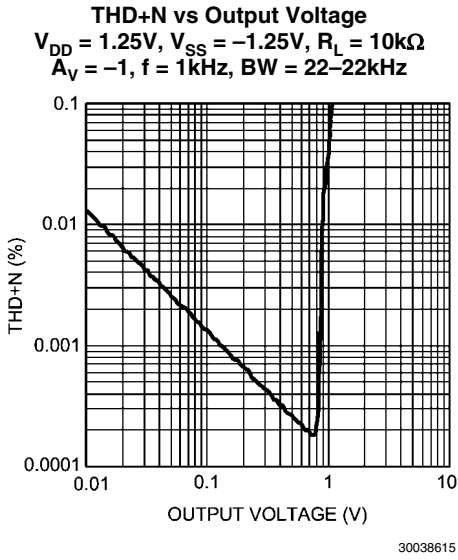
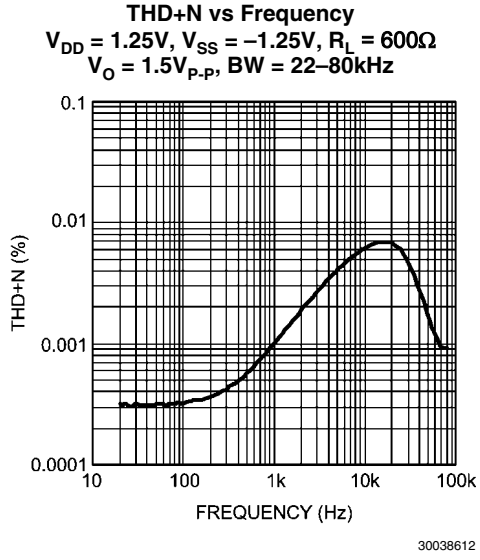
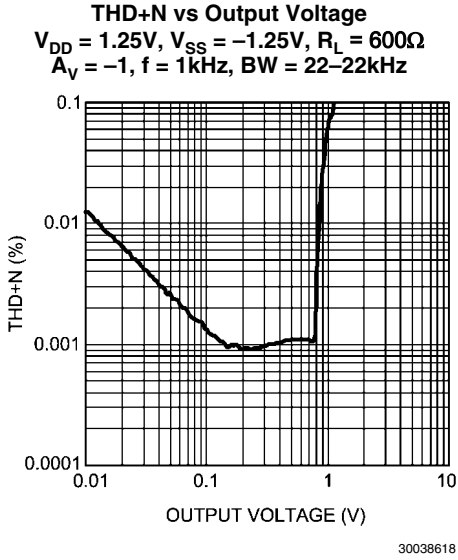

THD+N vs Output Voltage
 $V_{DD} = 2.50V, V_{SS} = -2.50V, R_L = 10k\Omega$
 $A_V = -1, f = 1kHz, BW = 22-22kHz$

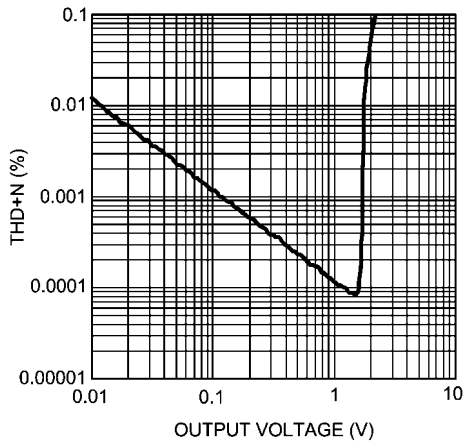

30038616

THD+N vs Frequency
 $V_{DD} = 2.50V, V_{SS} = -2.50V, R_L = 10k\Omega$
 $V_O = 1V_{p-p}, BW = 22-80kHz$

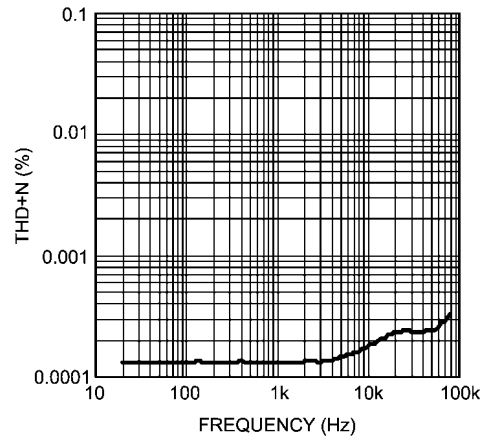

30038635

THD+N vs Output Voltage
 $V_{DD} = 2.75V, V_{SS} = -2.75V, R_L = 600\Omega$
 $A_V = -1, f = 1kHz, BW = 22-22kHz$

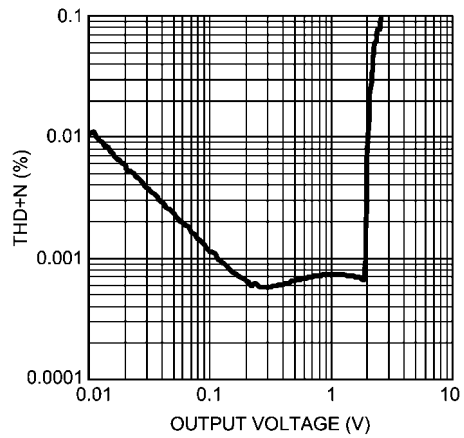

30038620

THD+N vs Frequency
 $V_{DD} = 2.75V, V_{SS} = -2.75V, R_L = 600\Omega$
 $V_O = 3.5V_{p-p}, BW = 22-80kHz$

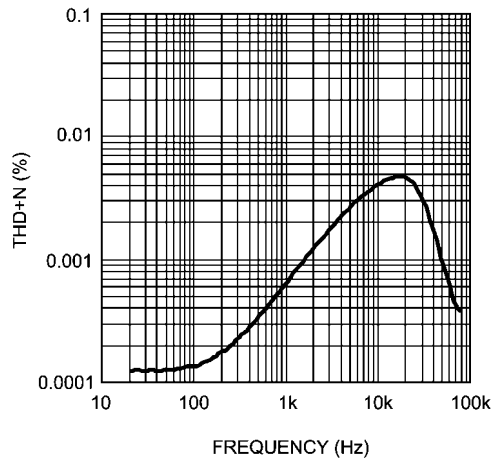

30038636

THD+N vs Output Voltage
 $V_{DD} = 2.75V, V_{SS} = -2.75V, R_L = 10k\Omega$
 $A_V = -1, f = 1kHz, BW = 22-22kHz$

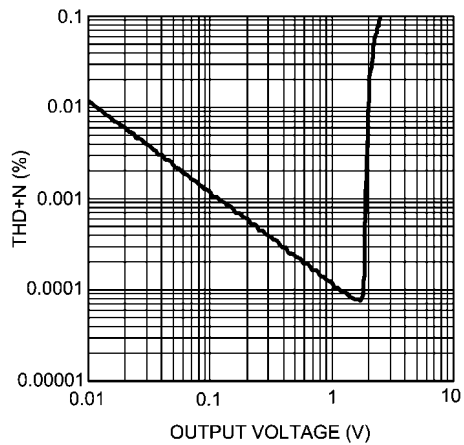

30038617

THD+N vs Frequency
 $V_{DD} = 2.75V, V_{SS} = -2.75V, R_L = 10k\Omega$
 $V_O = 3.5V_{p-p}, BW = 22-80kHz$

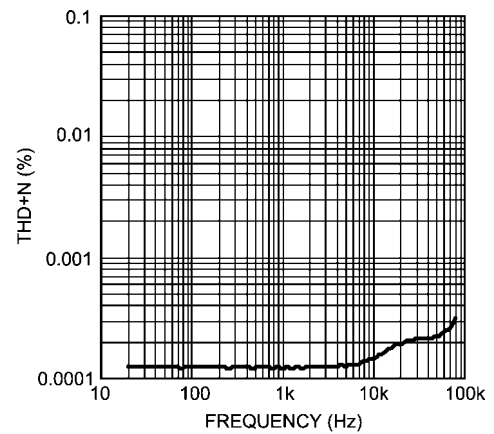

30038611

PSRR+ vs Frequency
 $V_{DD} = 1.25V, V_{SS} = -1.25V, V_{RIPPLE} = 200mV_{P-P}$
 Input terminated, BW = 22-80kHz

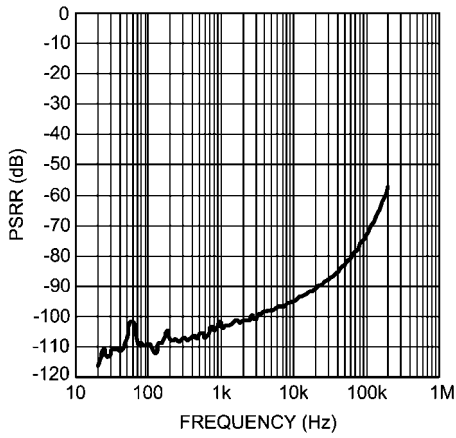

30038621

PSRR- vs Frequency
 $V_{DD} = 1.25V, V_{SS} = -1.25V, V_{RIPPLE} = 200mV_{P-P}$
 Input terminated, BW = 22-80kHz

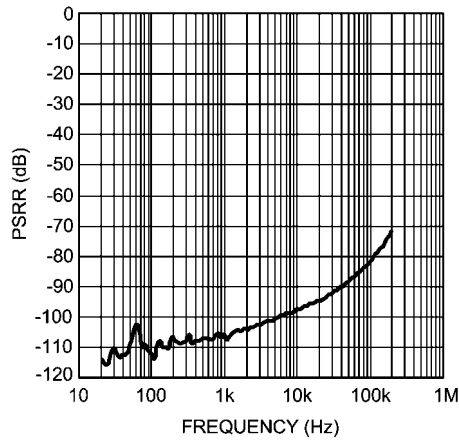

30038624

PSRR+ vs Frequency
 $V_{DD} = 2.50V, V_{EE} = -2.50V, V_{RIPPLE} = 200mV_{P-P}$
 Input terminated, BW = 22-80kHz

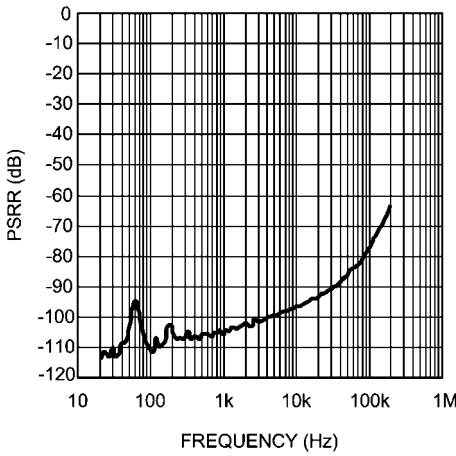

30038637

PSRR- vs Frequency
 $V_{DD} = 2.50V, V_{SS} = -2.50V, V_{RIPPLE} = 200mV_{P-P}$
 Input terminated, BW = 22-80kHz

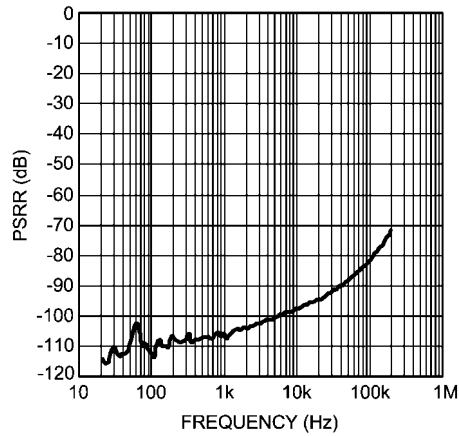

30038625

PSRR+ vs Frequency
 $V_{DD} = 2.75V, V_{SS} = -2.75V, V_{RIPPLE} = 200mV_{P-P}$
 Input terminated, BW = 22-80kHz

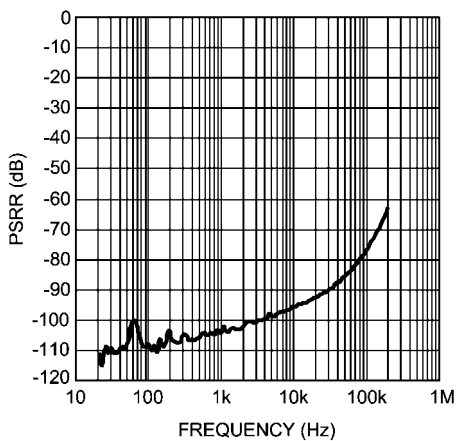

30038623

PSRR- vs Frequency
 $V_{DD} = 2.75V, V_{SS} = -2.75V, V_{RIPPLE} = 200mV_{P-P}$
 Input terminated, BW = 22-80kHz

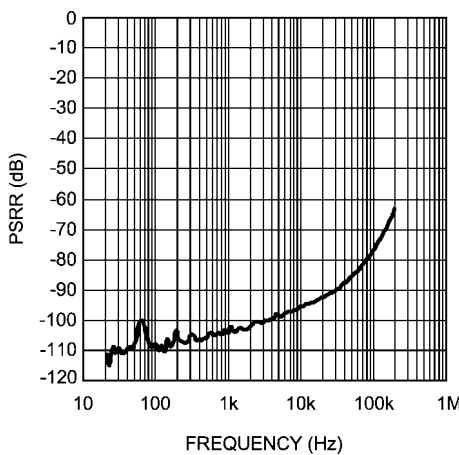

30038638

Output Voltage vs Supply Voltage
 $R_L = 600\Omega$, $A_V = -1$
 $f = 1\text{kHz}$, THD+N = 1%, BW = 22–80kHz

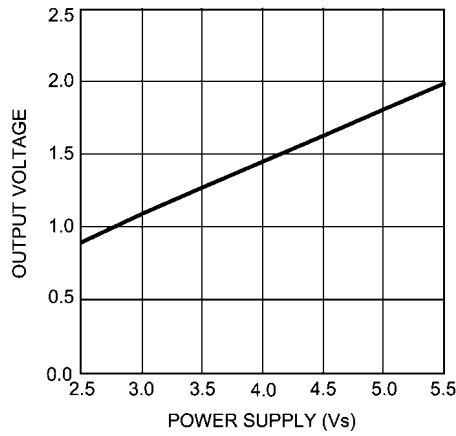

30038633

Output Voltage vs Supply Voltage
 $R_L = 10\text{k}\Omega$, $A_V = -1$
 $f = 1\text{kHz}$, THD+N = 1%, BW = 22–80kHz

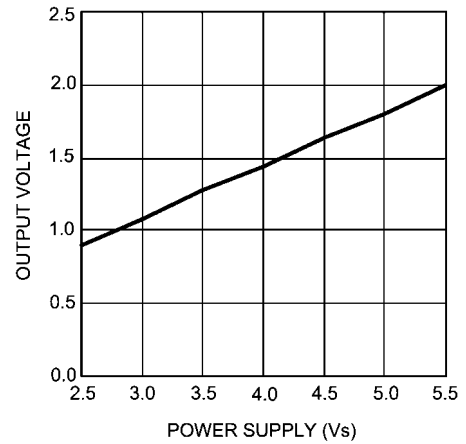

30038632

Crosstalk vs Frequency
 $V_{DD} = 2.50\text{V}$, $V_{SS} = -2.50\text{V}$, $R_L = 10\text{k}\Omega$
 $A_V = -1$, $f = 1\text{kHz}$, BW = 80kHz

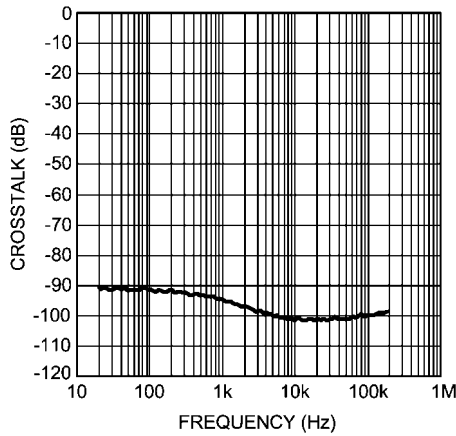

30038630

Supply Current vs Supply Voltage per Amplifier, $R_L = \text{No Load}$, $A_V = -1$

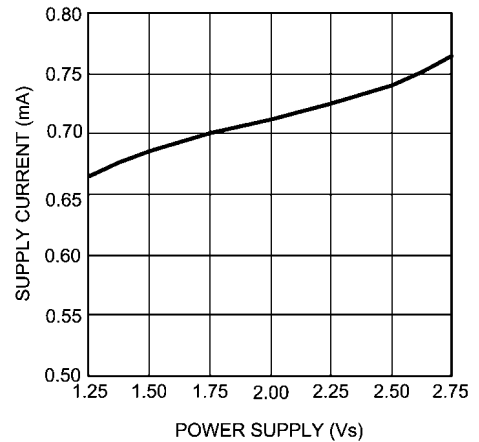

30038628

CMRR vs Frequency
 $V_{DD} = 2.5\text{V}$, $V_{SS} = -2.5\text{V}$, $V_{RIPPLE} = 200\text{mV}_{P-P}$

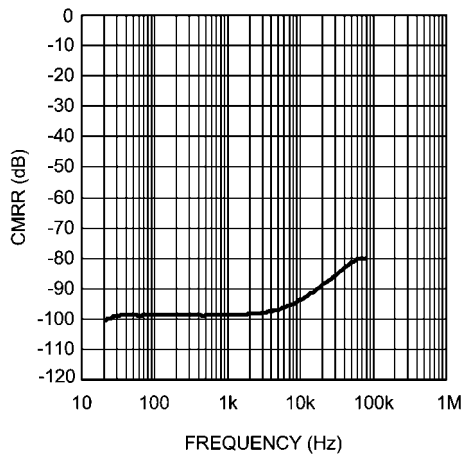

30038639

Application Information

DISTORTION MEASUREMENTS

The vanishingly low residual distortion produced by LME49726 is below the capabilities of all commercially available equipment. This makes distortion measurements just slightly more difficult than simply connecting a distortion meter to the amplifier's inputs and outputs. The solution, however, is quite simple: an additional resistor. Adding this resistor extends the resolution of the distortion measurement equipment.

The LME49726's low residual is an input referred internal error. As shown in Figure 3, adding the 10Ω resistor connected between the amplifier's inverting and non-inverting inputs

changes the amplifier's noise gain. The result is that the error signal (distortion) is amplified by a factor of 101. Although the amplifier's closed-loop gain is unaltered, the feedback available to correct distortion errors is reduced by 101. To ensure minimum effects on distortion measurements, keep the value of R_1 low as shown in Figure 3.

This technique is verified by duplicating the measurements with high closed loop gain and/or making the measurements at high frequencies. Doing so, produces distortion components that are within measurement equipment capabilities. This datasheet's THD+N and IMD values were generated using the above described circuit connected to an Audio Precision System Two Cascade.

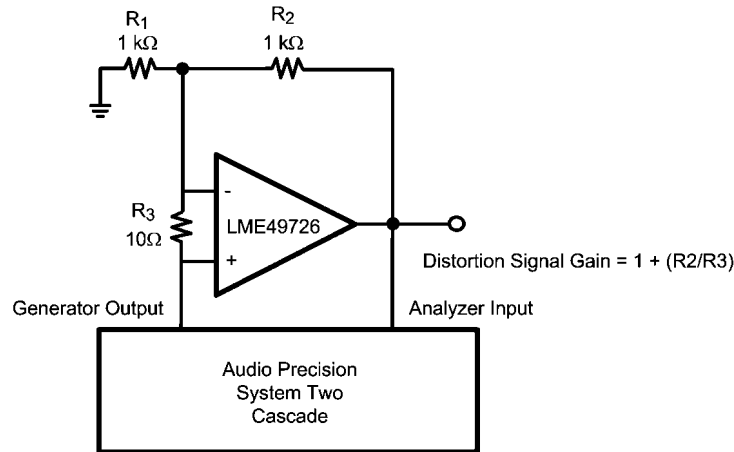

300386x2

FIGURE 3. THD+N and IMD Distortion Test Circuit

OPERATING RATINGS AND BASIC DESIGN GUIDELINES

The LME49726 has a supply voltage range from +2.5V to +5.5V single supply or ± 1.25 to ± 2.75 V dual supply.

Bypassed capacitors for the supplies should be placed as close to the amplifier as possible. This will help minimize any inductance between the power supply and the supply pins. In addition to a $10\mu\text{F}$ capacitor, a $0.1\mu\text{F}$ capacitor is also recommended in CMOS amplifiers.

The amplifier's input lead lengths should also be as short as possible. If the op amp does not have a bypass capacitor, it may oscillate.

BASIC AMPLIFIER CONFIGURATIONS

The LME49726 may be operated with either a single supply or dual supplies. Figure 2 shows the typical connection for a single supply inverting amplifier. The output voltage for a single supply amplifier will be centered around the common-mode voltage, V_{CM} . Note, the voltage applied to the V_{CM} insures the output stays above ground. Typically, the V_{CM} should be equal to $V_{DD}/2$. This is done by putting a resistor divider circuit at this node, see Figure 4.

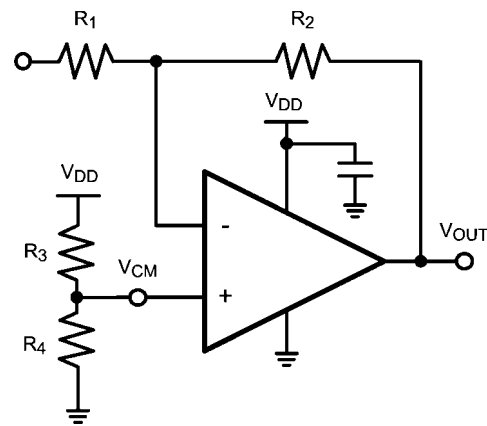

300386n3

FIGURE 4. Single Supply Inverting Op Amp

Figure 5 shows the typical connection for a dual supply inverting amplifier. The output voltage is centered on zero.

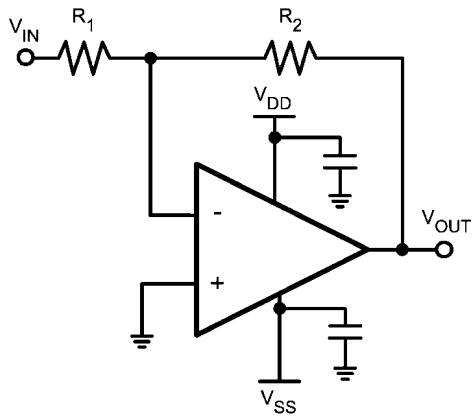

300386n2

FIGURE 5. Dual Supply Inverting Configuration

Figure 6 shows the typical connection for the Buffer Amplifier or also called a Voltage Follower. The Buffer is a unity gain stable amplifier.

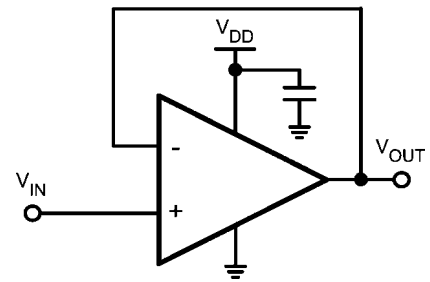

300386n1

FIGURE 6. Unity-Gain Buffer Configuration

Typical Applications

NAB Preamp

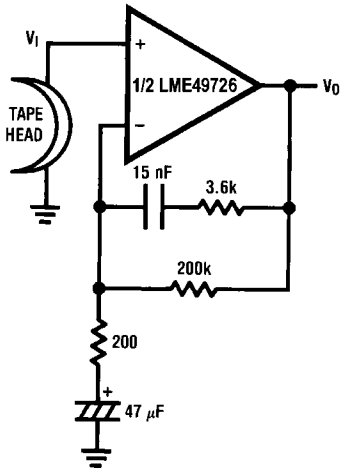

300386n4

$A_V = 34.5$
 $F = 1 \text{ kHz}$
 $E_n = 0.38 \mu\text{V}$
 A Weighted

$A_V = 34.5$
 $F = 1 \text{ kHz}$
 $E_n = 0.38 \mu\text{V}$
 A Weighted

NAB Preamp Voltage Gain vs Frequency

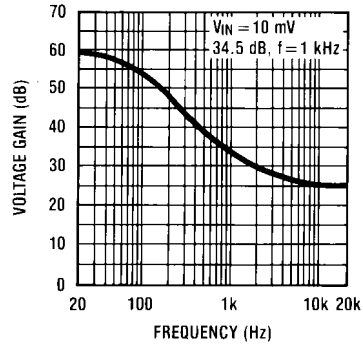

300386n5

Balanced to Single Ended Converter

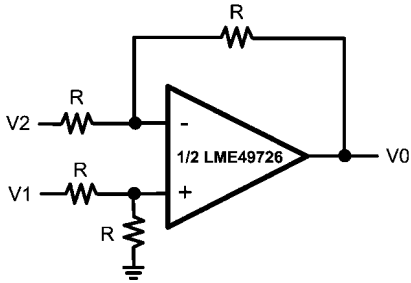

300386n6

$$V_O = V1 - V2$$

Adder/Subtractor

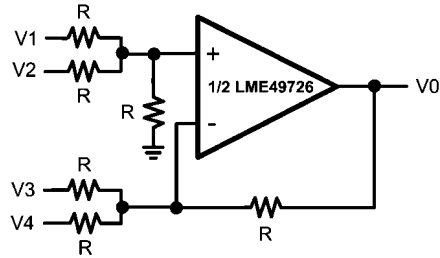

300386n7

$$V_O = V1 + V2 - V3 - V4$$

Sine Wave Oscillator

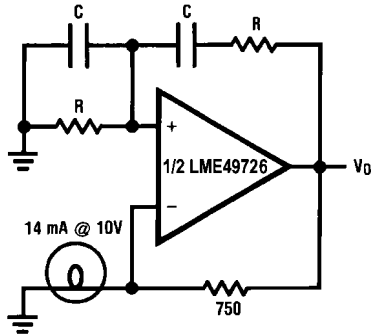

300386n8

$$f_o = \frac{1}{2\pi RC}$$

Second Order High Pass Filter (Butterworth)

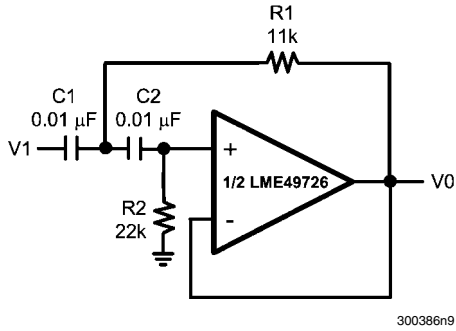

300386n9

if $C1 = C2 = C$

$$R1 = \frac{\sqrt{2}}{2\omega_0 C}$$

$$R2 = 2 \cdot R1$$

Illustration is $f_0 = 1 \text{ kHz}$

Second Order Low Pass Filter (Butterworth)

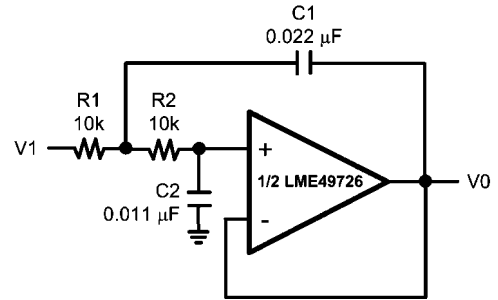

300386o0

if $R1 = R2 = R$

$$C1 = \frac{\sqrt{2}}{\omega_0 R}$$

$$C2 = \frac{C1}{2}$$

Illustration is $f_0 = 1 \text{ kHz}$

State Variable Filter

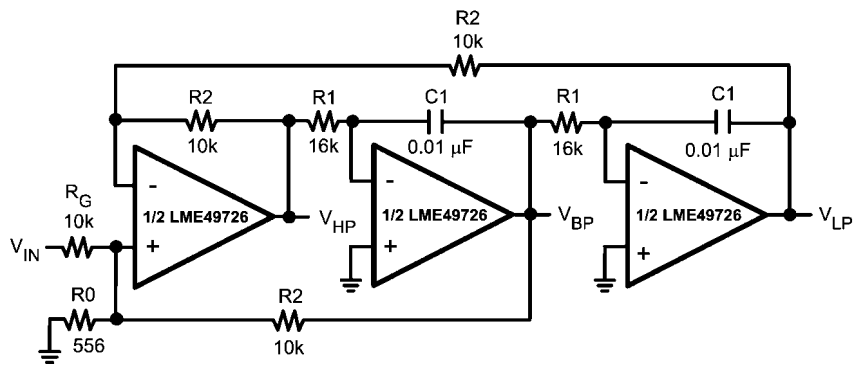

300386o1

$$f_0 = \frac{1}{2\pi C1R1}, Q = \frac{1}{2} \left(1 + \frac{R2}{R0} + \frac{R2}{RG} \right), A_{BP} = QA_{LP} = QA_{LH} = \frac{R2}{RG}$$

Illustration is $f_0 = 1 \text{ kHz}, Q = 10, A_{BP} = 1$

AC/DC Converter

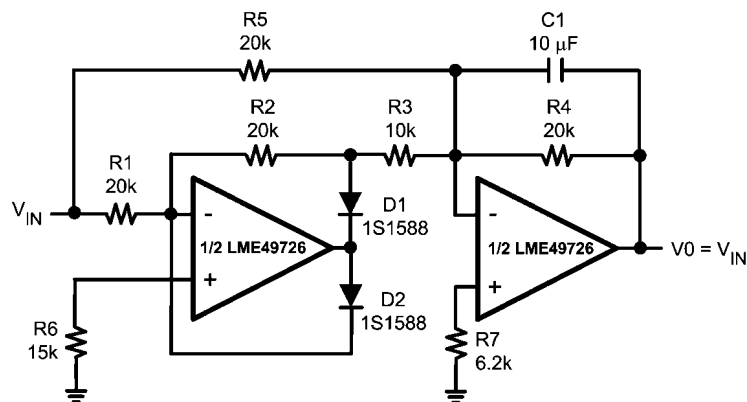

300386o2

2 Channel Panning Circuit (Pan Pot)

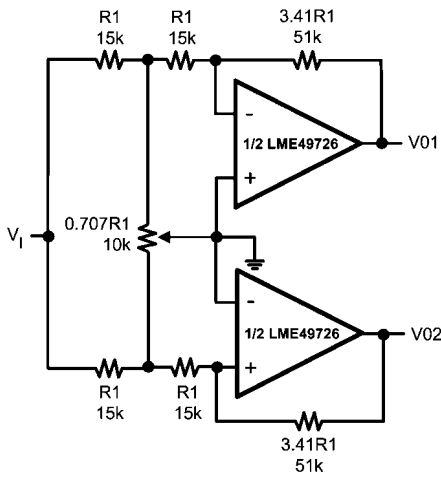

300386o3

Line Driver

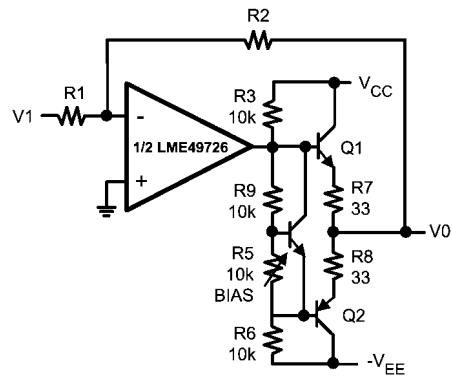

300386o4

Tone Control

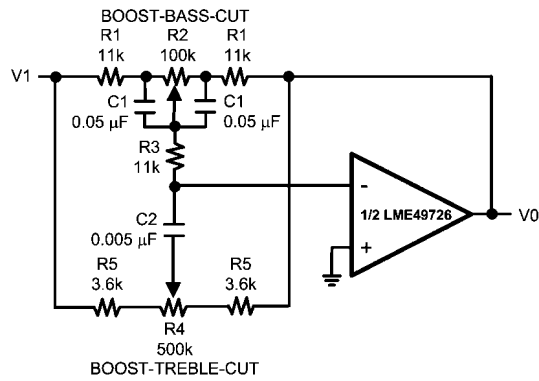

300386o5

$$f_L = \frac{1}{2\pi R2C1}, f_{LB} = \frac{1}{2\pi R1C1}$$

$$f_H = \frac{1}{2\pi R5C2}, f_{HB} = \frac{1}{2\pi(R1 + R5 + 2R3)C2}$$

Illustration is:

$f_L = 32 \text{ Hz}$, $f_{LB} = 320 \text{ Hz}$
 $f_H = 11 \text{ kHz}$, $f_{HB} = 1.1 \text{ kHz}$

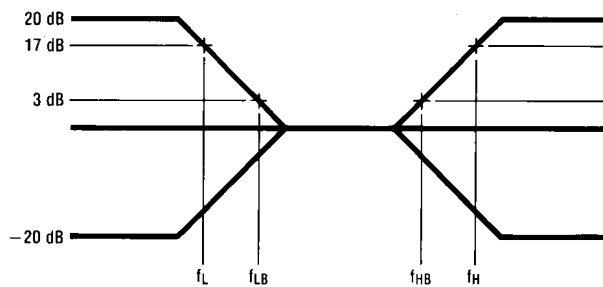

300386o6

RIAA Preamp

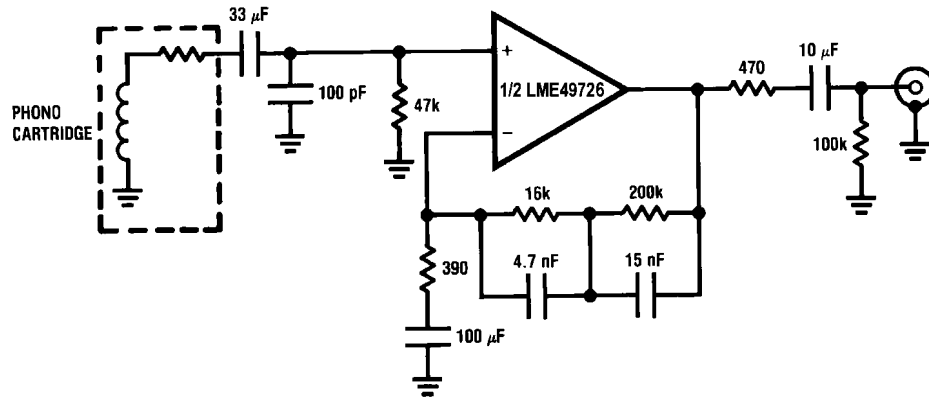

30038608

$A_v = 35 \text{ dB}$
 $E_n = 0.33 \text{ } \mu\text{V}$
 $S/N = 90 \text{ dB}$
 $f = 1 \text{ kHz}$
 A Weighted
 A Weighted, $V_{IN} = 10 \text{ mV}$
 @ $f = 1 \text{ kHz}$

Balanced Input Mic Amp

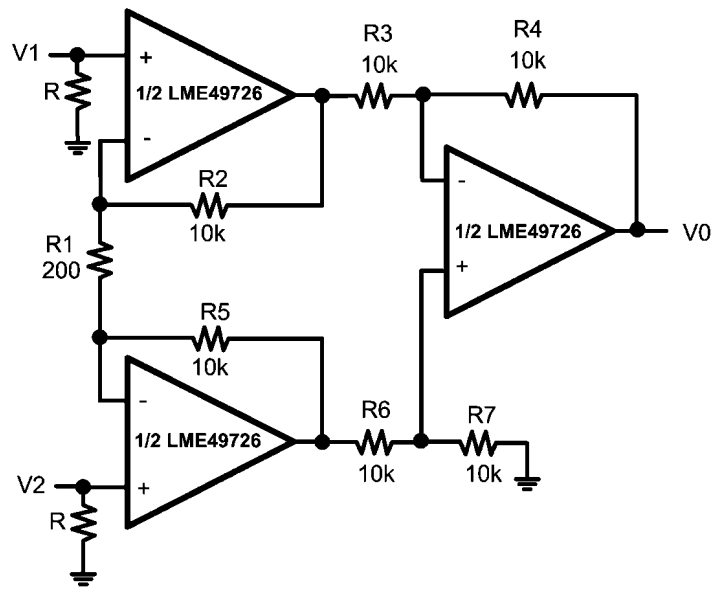

30038607

If $R_2 = R_5, R_3 = R_6, R_4 = R_7$

$$V_0 = \left(1 + \frac{2R_2}{R_1}\right) \frac{R_4}{R_3} (V_2 - V_1)$$

Illustration is:
 $V_0 = 101(V_2 - V_1)$

10 Band Graphic Equalizer

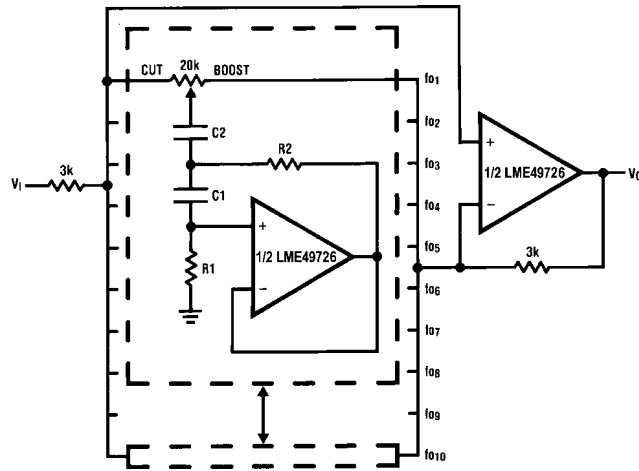

300386p0

fo (Hz)	C ₁	C ₂	R ₁	R ₂
32	0.12μF	4.7μF	75kΩ	500Ω
64	0.056μF	3.3μF	68kΩ	510Ω
125	0.033μF	1.5μF	62kΩ	510Ω
250	0.015μF	0.82μF	68kΩ	470Ω
500	8200pF	0.39μF	62kΩ	470Ω
1k	3900pF	0.22μF	68kΩ	470Ω
2k	2000pF	0.1μF	68kΩ	470Ω
4k	1100pF	0.056μF	62kΩ	470Ω
8k	510pF	0.022μF	68kΩ	510Ω
16k	330pF	0.012μF	51kΩ	510Ω

Note 8: At volume of change = ±12 dB

Q = 1.7

Reference: "AUDIO/RADIO HANDBOOK", National Semiconductor, 1980, Page 2-61

LME49726 Bill of Materials

Description	Designator	Part Number	Manufacturer	Quantity/Brd
Ceramic Capacitor 0.1uF, 10%, 50V 0805 SMD	C1, C2, C5–C8	08055C104KAT2A	AVX	2
Tantalum Capacitor 2.2uF, 10%, 20V, A-size	C9, C11	T491A225K020AT	Kemet	Not Stuff
Tantalum Capacitor 10uF, 10%, 20V, B-size	C3, C4	T491B106K020AT	Kemet	2
Resistor 0Ω, 1/8W 1% 0805 SMD	R1, R4, R6, R9, R13, R14	CRCW08050000Z0EA	Vishay	6
Header, 2-Pin	JP1, JP2, JP3, JP4	HDR1X2	Header 2	4
Header, 3-Pin	JP5	HDR1X3	Header 3	1
Resistor 10kΩ, 1/8W 1% 0805 SMD	R2, R3, R7, R8	CRCW080510K0FKEA	Vishay	4
Dual Rail-to-Rail Op Amp	U1	LME49726	National Semiconductor	1
Resistor 100meg/open 1/8W 0805 SMD	R5, R10, R11, R12	OPEN N/A	N/A	0

LME49726 Board Circuit

LME49726

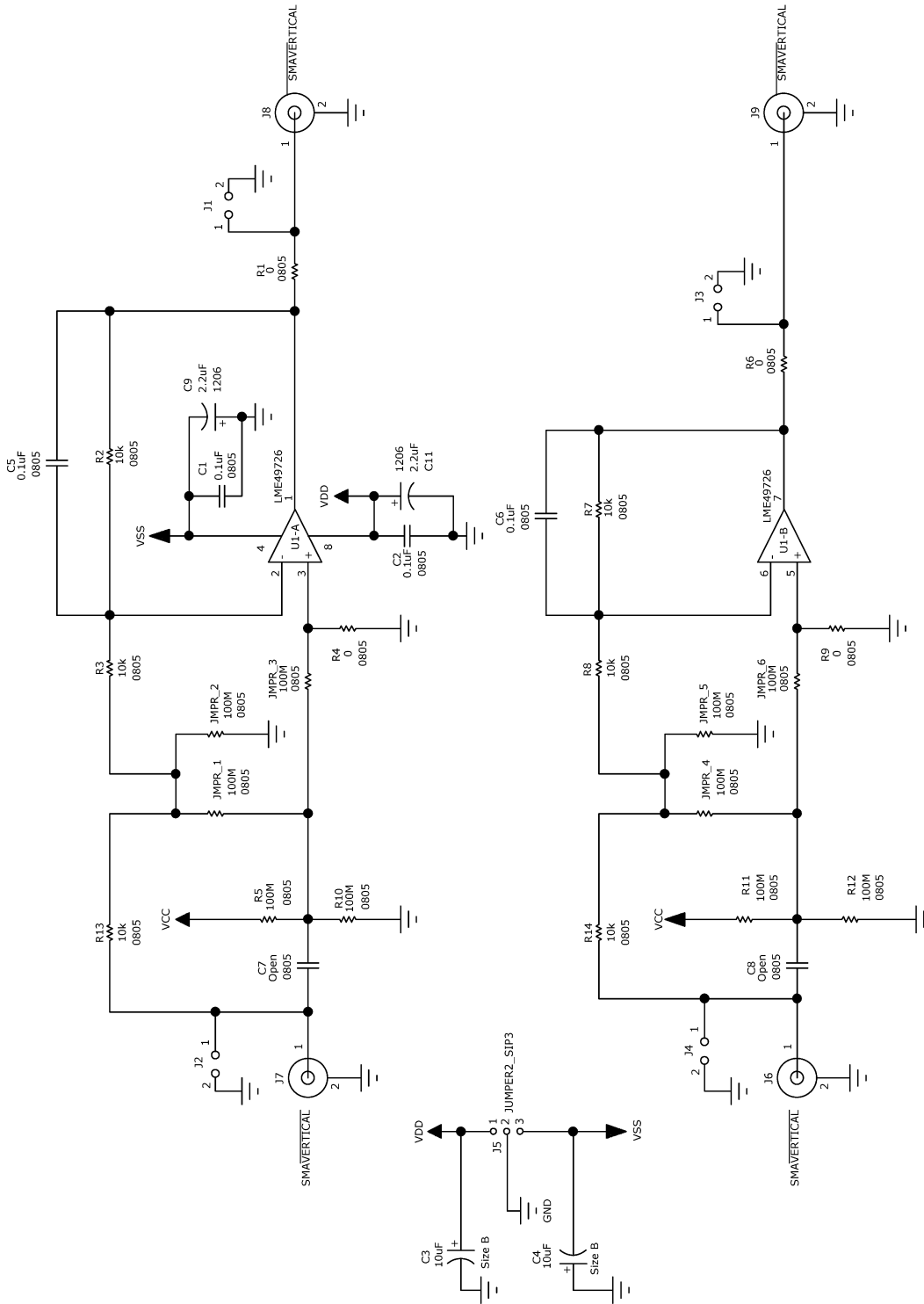

300388640

LME49726 Demo Board Views

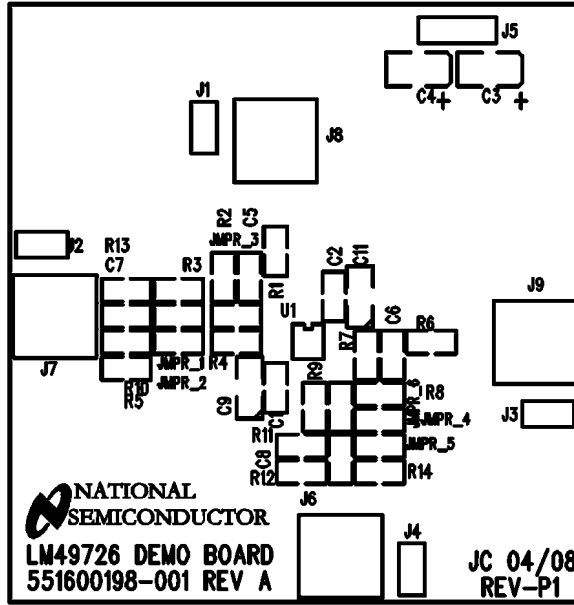

Top Silkscreen

30038641

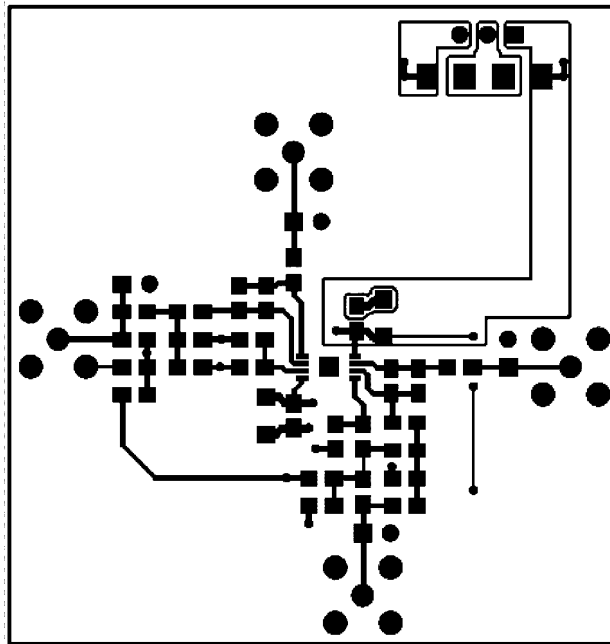

Top Layer

300386x9

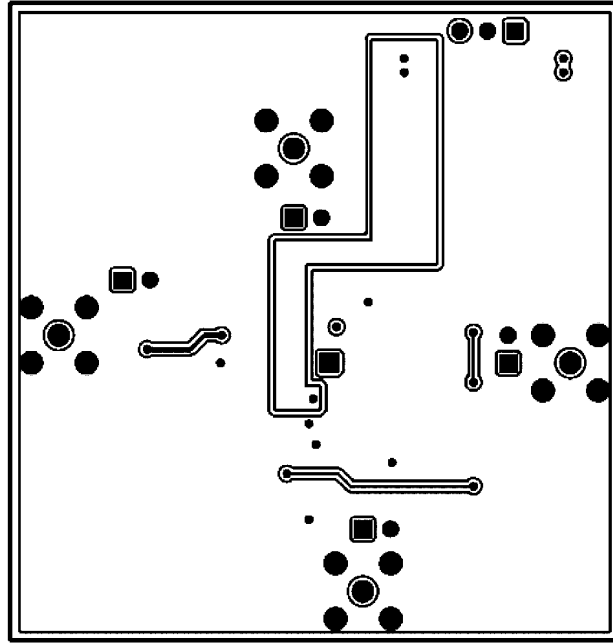

Bottom Layer

300386x8

Revision History

Rev	Date	Description
1.0	11/05/08	Initial release.
1.01	05/25/10	Increased Operating Temperature Range.

Physical Dimensions inches (millimeters) unless otherwise noted

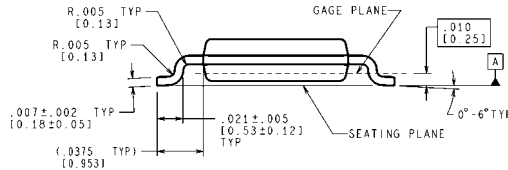
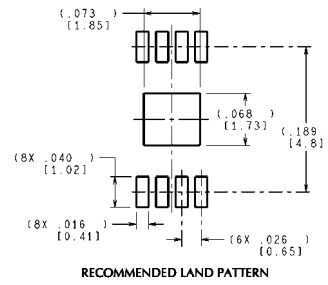
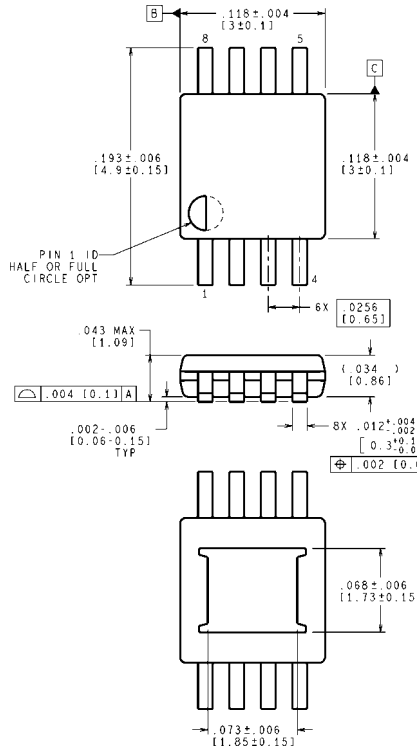

CONTROLLING DIMENSION IS INCH
VALUES IN [] ARE MILLIMETERS

Mini-SOIC Exposed-DAP Package
Order Number LME49726MY
NS Package Number MUY08A

MUY08A (Rev A)

Notes

For more National Semiconductor product information and proven design tools, visit the following Web sites at:
www.national.com

Products		Design Support	
Amplifiers	www.national.com/amplifiers	WEBENCH® Tools	www.national.com/webench
Audio	www.national.com/audio	App Notes	www.national.com/appnotes
Clock and Timing	www.national.com/timing	Reference Designs	www.national.com/refdesigns
Data Converters	www.national.com/adc	Samples	www.national.com/samples
Interface	www.national.com/interface	Eval Boards	www.national.com/evalboards
LVDS	www.national.com/lvds	Packaging	www.national.com/packaging
Power Management	www.national.com/power	Green Compliance	www.national.com/quality/green
Switching Regulators	www.national.com/switchers	Distributors	www.national.com/contacts
LDOs	www.national.com/ldo	Quality and Reliability	www.national.com/quality
LED Lighting	www.national.com/led	Feedback/Support	www.national.com/feedback
Voltage References	www.national.com/vref	Design Made Easy	www.national.com/easy
PowerWise® Solutions	www.national.com/powerwise	Applications & Markets	www.national.com/solutions
Serial Digital Interface (SDI)	www.national.com/sdi	Mil/Aero	www.national.com/milaero
Temperature Sensors	www.national.com/tempensors	SolarMagic™	www.national.com/solarmagic
PLL/VCO	www.national.com/wireless	PowerWise® Design University	www.national.com/training

THE CONTENTS OF THIS DOCUMENT ARE PROVIDED IN CONNECTION WITH NATIONAL SEMICONDUCTOR CORPORATION ("NATIONAL") PRODUCTS. NATIONAL MAKES NO REPRESENTATIONS OR WARRANTIES WITH RESPECT TO THE ACCURACY OR COMPLETENESS OF THE CONTENTS OF THIS PUBLICATION AND RESERVES THE RIGHT TO MAKE CHANGES TO SPECIFICATIONS AND PRODUCT DESCRIPTIONS AT ANY TIME WITHOUT NOTICE. NO LICENSE, WHETHER EXPRESS, IMPLIED, ARISING BY ESTOPPEL OR OTHERWISE, TO ANY INTELLECTUAL PROPERTY RIGHTS IS GRANTED BY THIS DOCUMENT.

TESTING AND OTHER QUALITY CONTROLS ARE USED TO THE EXTENT NATIONAL DEEMS NECESSARY TO SUPPORT NATIONAL'S PRODUCT WARRANTY. EXCEPT WHERE MANDATED BY GOVERNMENT REQUIREMENTS, TESTING OF ALL PARAMETERS OF EACH PRODUCT IS NOT NECESSARILY PERFORMED. NATIONAL ASSUMES NO LIABILITY FOR APPLICATIONS ASSISTANCE OR BUYER PRODUCT DESIGN. BUYERS ARE RESPONSIBLE FOR THEIR PRODUCTS AND APPLICATIONS USING NATIONAL COMPONENTS. PRIOR TO USING OR DISTRIBUTING ANY PRODUCTS THAT INCLUDE NATIONAL COMPONENTS, BUYERS SHOULD PROVIDE ADEQUATE DESIGN, TESTING AND OPERATING SAFEGUARDS.

EXCEPT AS PROVIDED IN NATIONAL'S TERMS AND CONDITIONS OF SALE FOR SUCH PRODUCTS, NATIONAL ASSUMES NO LIABILITY WHATSOEVER, AND NATIONAL DISCLAIMS ANY EXPRESS OR IMPLIED WARRANTY RELATING TO THE SALE AND/OR USE OF NATIONAL PRODUCTS INCLUDING LIABILITY OR WARRANTIES RELATING TO FITNESS FOR A PARTICULAR PURPOSE, MERCHANTABILITY, OR INFRINGEMENT OF ANY PATENT, COPYRIGHT OR OTHER INTELLECTUAL PROPERTY RIGHT.

LIFE SUPPORT POLICY

NATIONAL'S PRODUCTS ARE NOT AUTHORIZED FOR USE AS CRITICAL COMPONENTS IN LIFE SUPPORT DEVICES OR SYSTEMS WITHOUT THE EXPRESS PRIOR WRITTEN APPROVAL OF THE CHIEF EXECUTIVE OFFICER AND GENERAL COUNSEL OF NATIONAL SEMICONDUCTOR CORPORATION. As used herein:

Life support devices or systems are devices which (a) are intended for surgical implant into the body, or (b) support or sustain life and whose failure to perform when properly used in accordance with instructions for use provided in the labeling can be reasonably expected to result in a significant injury to the user. A critical component is any component in a life support device or system whose failure to perform can be reasonably expected to cause the failure of the life support device or system or to affect its safety or effectiveness.

National Semiconductor and the National Semiconductor logo are registered trademarks of National Semiconductor Corporation. All other brand or product names may be trademarks or registered trademarks of their respective holders.

Copyright© 2010 National Semiconductor Corporation

For the most current product information visit us at www.national.com



National Semiconductor Americas Technical Support Center
 Email: support@nsc.com
 Tel: 1-800-272-9959

National Semiconductor Europe Technical Support Center
 Email: europe.support@nsc.com

National Semiconductor Asia Pacific Technical Support Center
 Email: ap.support@nsc.com

National Semiconductor Japan Technical Support Center
 Email: jpn.feedback@nsc.com