

## 3A POWER OPERATIONAL AMPLIFIER

- OUTPUT CURRENT UP TO 3A
- LARGE COMMON-MODE AND DIFFERENTIAL MODE RANGES
- SOA PROTECTION
- THERMAL PROTECTION
- $\pm 18V$  SUPPLY

### DESCRIPTION

The L165 is a monolithic integrated circuit in Pentawatt® package, intended for use as power operational amplifier in a wide range of applications, including servo amplifiers and power supplies. The high gain and high output power capability provide superior performance wherever an operational amplifier/power booster combination is required.

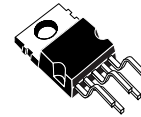

Pentawatt V

ORDERING NUMBER: L165V

### APPLICATION CIRCUITS

Figure 1. Gain > 10.

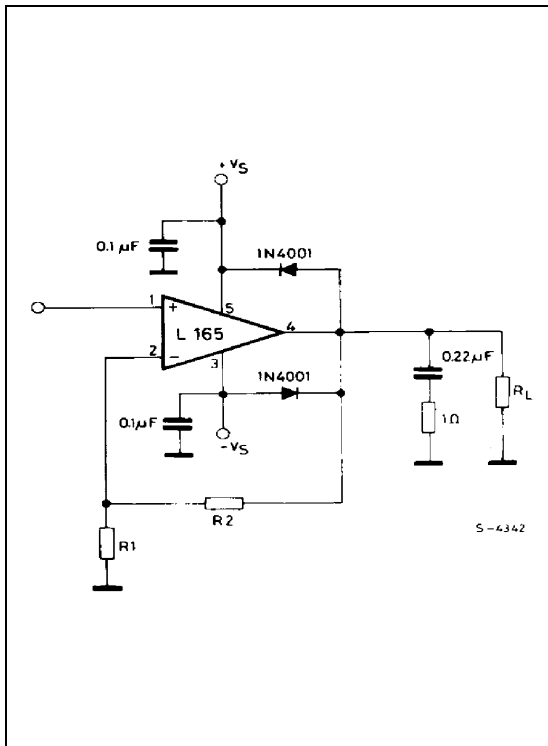
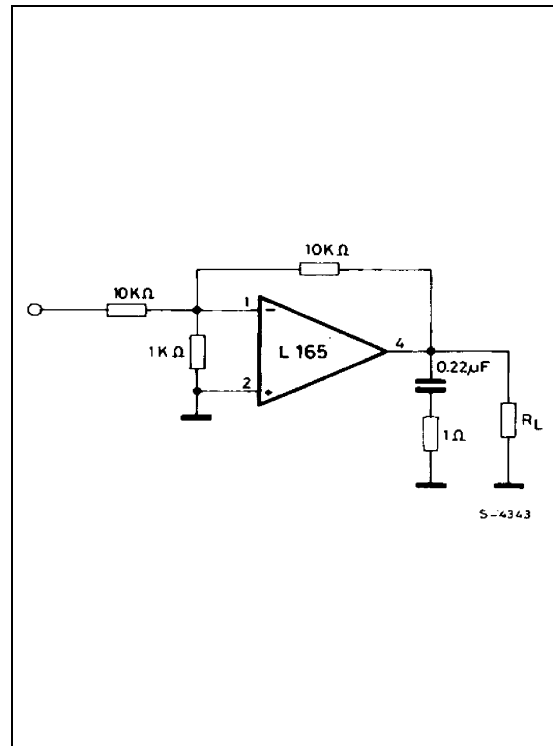

Figure 2. Unity gain configuration.



**ABSOLUTE MAXIMUM RATINGS**

Symbol	Parameter	Value	Unit
$V_S$	Supply voltage	$\pm 18$	V
$V_5 V_4$	Upper power transistor $V_{CE}$	36	V
$V_4 V_3$	Lower power transistor $V_{CE}$	36	V
$V_i$	Input voltage	$V_S$	
$V_j$	Differential input voltage	$\pm 15$	V
$I_o$	Peak output current (internally limited)	3.5	A
$P_{tot}$	Power dissipation at $T_{case} = 90^\circ C$	20	W
$T_{stg}, T_j$	Storage and junction temperature	-40 to 150	$^\circ C$

**PIN CONNECTION (Top view)**

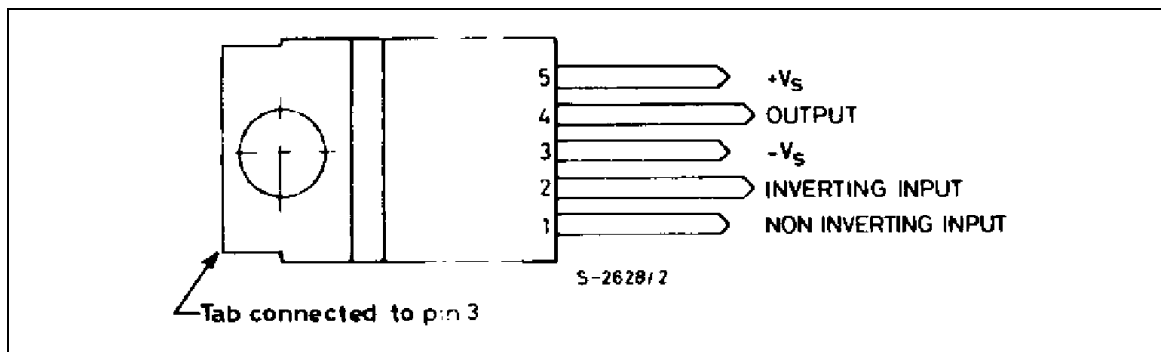

**SCHEMATIC DIAGRAM**

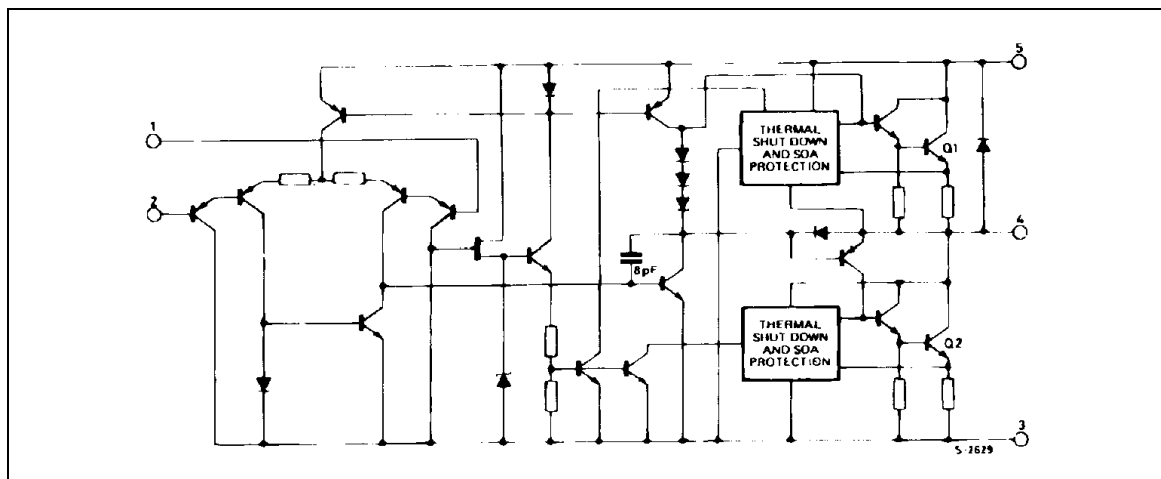

**THERMAL DATA**

Symbol	Parameter	Value	Unit
$R_{th-j-case}$	Thermal resistance junction-case	max 3	$^\circ C/W$

**ELECTRICAL CHARACTERISTICS** ( $V_S = \pm 15\text{ V}$ ,  $T_j = 25\text{ }^\circ\text{C}$  unless otherwise specified)

Symbol	Parameter	Test Condition	Min.	Typ.	Max.	Unit
$V_S$	Supply Voltage		$\pm 6$		$\pm 18$	V
$I_d$	Quiescent Drain Current	$V_S = \pm 18\text{ V}$		40	60	mA
$I_b$	Input Bias Current			0.2	1	$\mu\text{A}$
$V_{os}$	Input Offset Voltage			$\pm 2$	$\pm 10$	mV
$I_{os}$	Input Offset Current			$\pm 20$	$\pm 200$	nA
SR	Slew-rate	$G_v = 10$	8			V/ $\mu\text{s}$
		$G_v = 1\text{ }^\circ$	6			
$V_o$	Output Voltage Swing	$f = 1\text{ kHz}$ $I_p = 0.3\text{ A}$ $I_p = 3\text{ A}$		27 24		$V_{pp}$
		$f = 10\text{ kHz}$ $I_p = 0.3\text{ A}$ $I_p = 3\text{ A}$		27 24		$V_{pp}$
R	Input Resistance (pin 1)	$f = 1\text{ KHz}$	100	500		K $\Omega$
$G_v$	Voltage Gain (open loop)			80		dB
$e_N$	Input Noise Voltage	$B = 10\text{ to }10\,000\text{ Hz}$		2		$\mu\text{V}$
$i_N$	Input Noise Current	$f = 1\text{ KHz}$		100		pA
CMR	Common-mode Rejection	$R_g \leq 10\text{ K}\Omega$ ; $G_v = 30\text{ dB}$		70		dB
SVR	Supply Voltage Rejection	$R_g = 22\text{ K}\Omega$ ; $V_{ripple} = 0.5\text{ V}_{rms}$ $f_{ripple} = 100\text{ Hz}$ $G_v = 10$ $G_v = 100$		60 40		dB dB
	Efficiency	$f = 1\text{ kHz}$ ; $R_L = 4\Omega$ $I_p = 1.6\text{ A}$ ; $P_o = 5\text{ W}$ $I_p = 1.6\text{ A}$ ; $P_o = 18\text{ W}$		70 60		% %
$T_{sd}$			Thermal Shut-down Case Temperature	$P_{tot} = 12\text{ W}$		110
		$P_{tot} = 6\text{ W}$		130		$^\circ\text{C}$

Figure 3. Open loop frequency response.

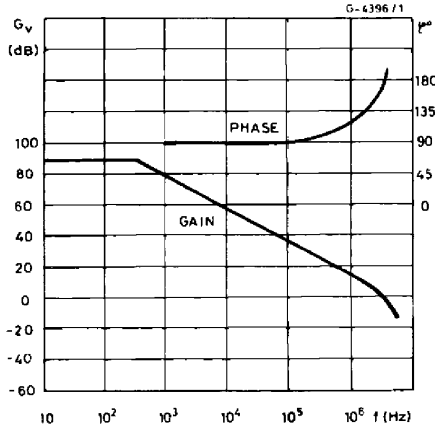

Figure 4. Closed loop frequency response (circuit of figure 2).

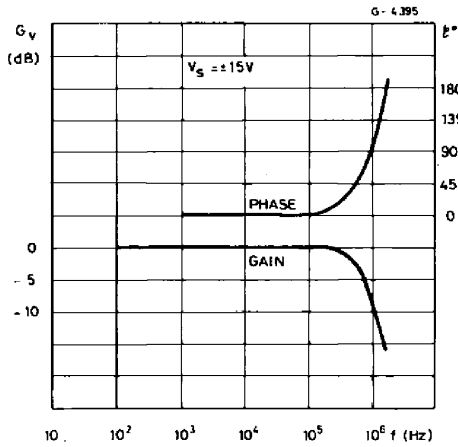

Figure 5. Large signal frequency response.

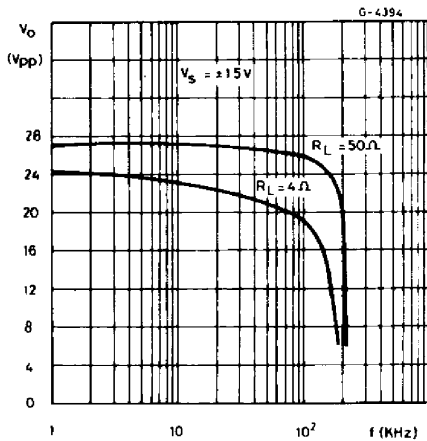

Figure 6. Maximum output current vs. voltage [VCE] across each output transistor.

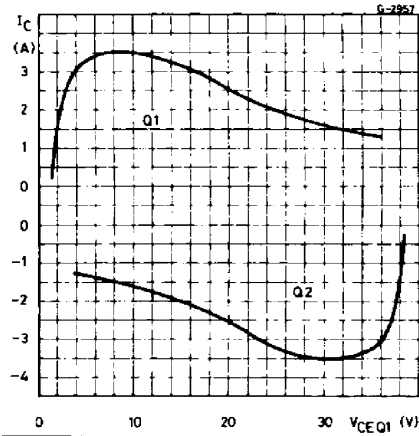

Figure 7. Safe operating area and collector characteristics of the protected power transistor.

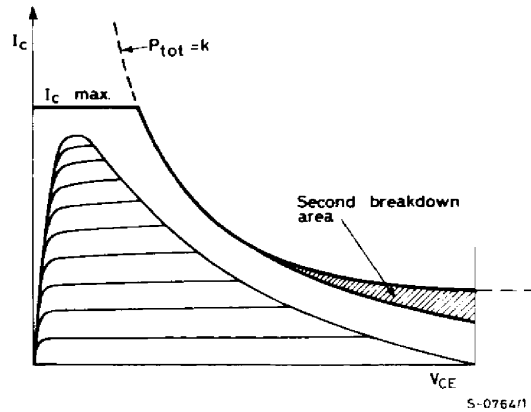

Figure 8. Maximum allowable power dissipation vs. ambient temperature.

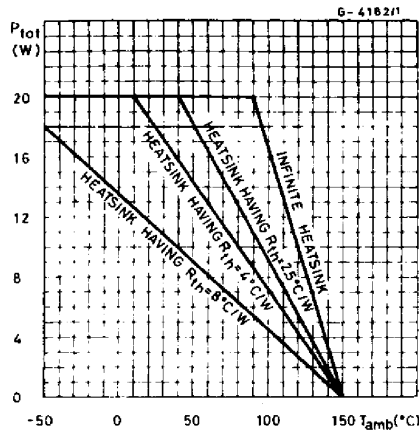

Figure 9. Bidirectional DC motor control with TTL/CMOS/ $\mu$ P compatible inputs.

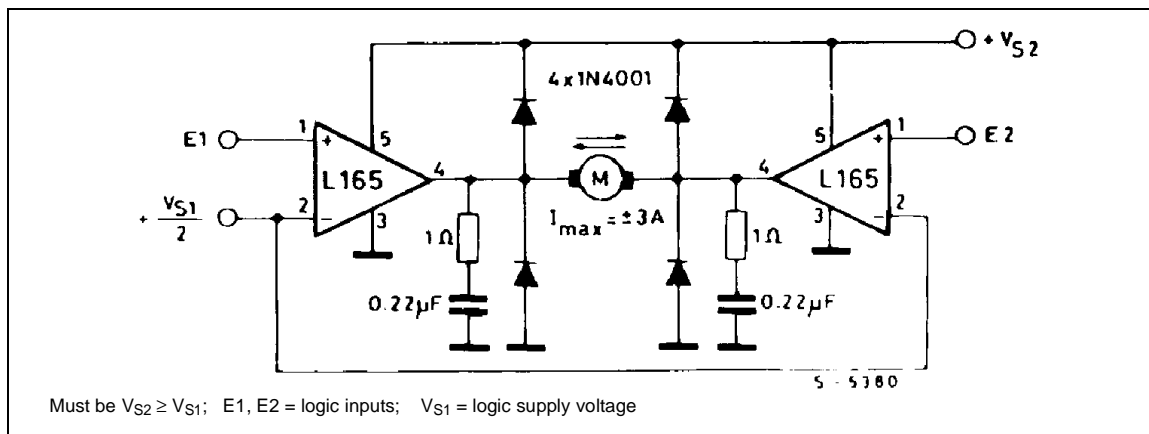

Figure 10. Motor current control circuit with external power transistors ( $I_{\text{motor}} > 3.5\text{A}$ ).

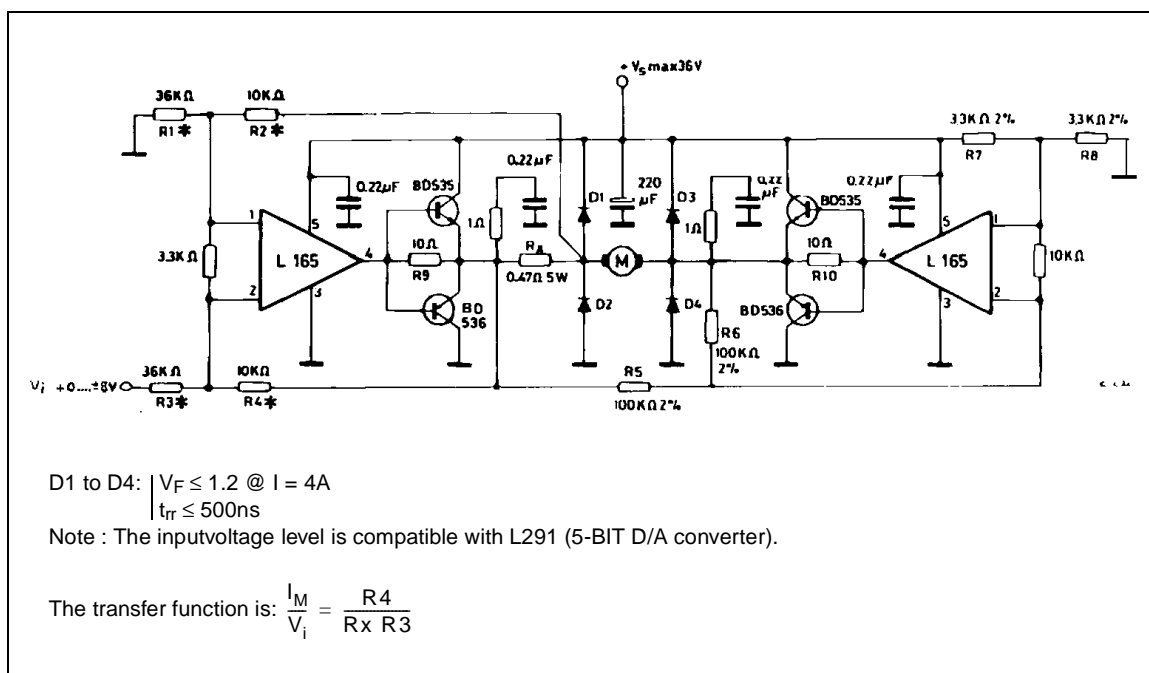

Figure 11. High current tracking regulator.

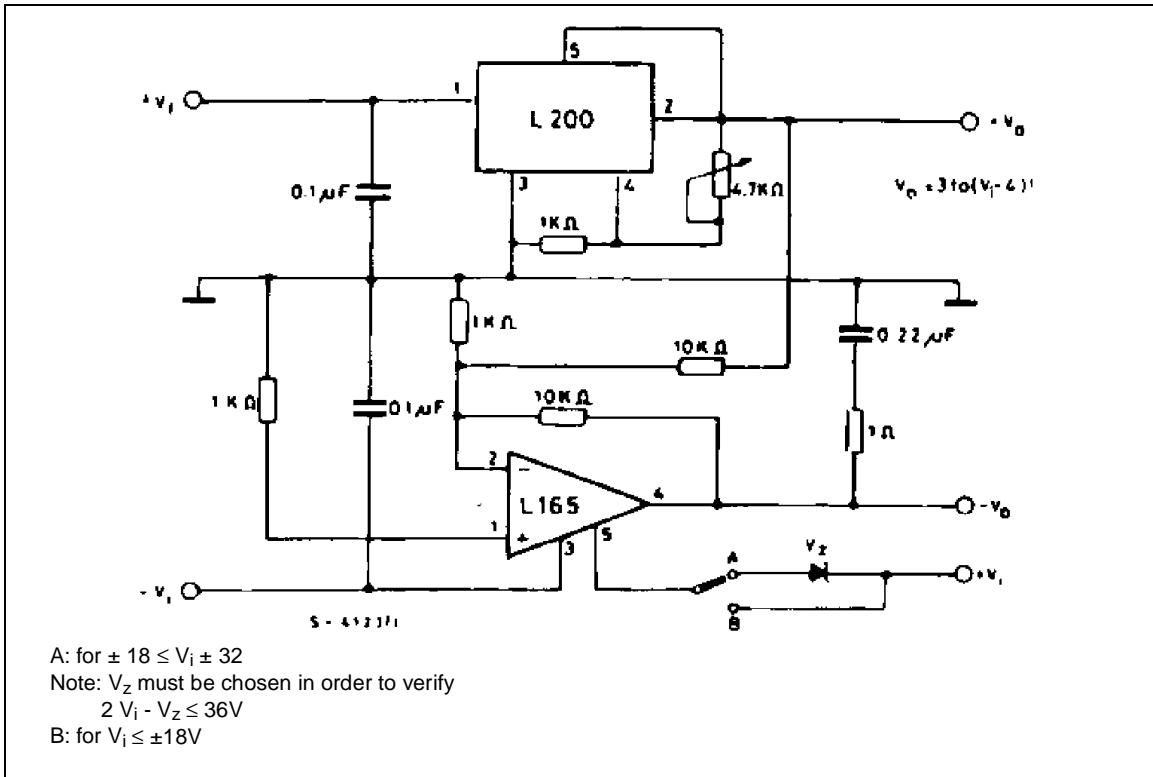

Figure 12. Bidirectional speed control of DC motor (Compensation networks not shown).

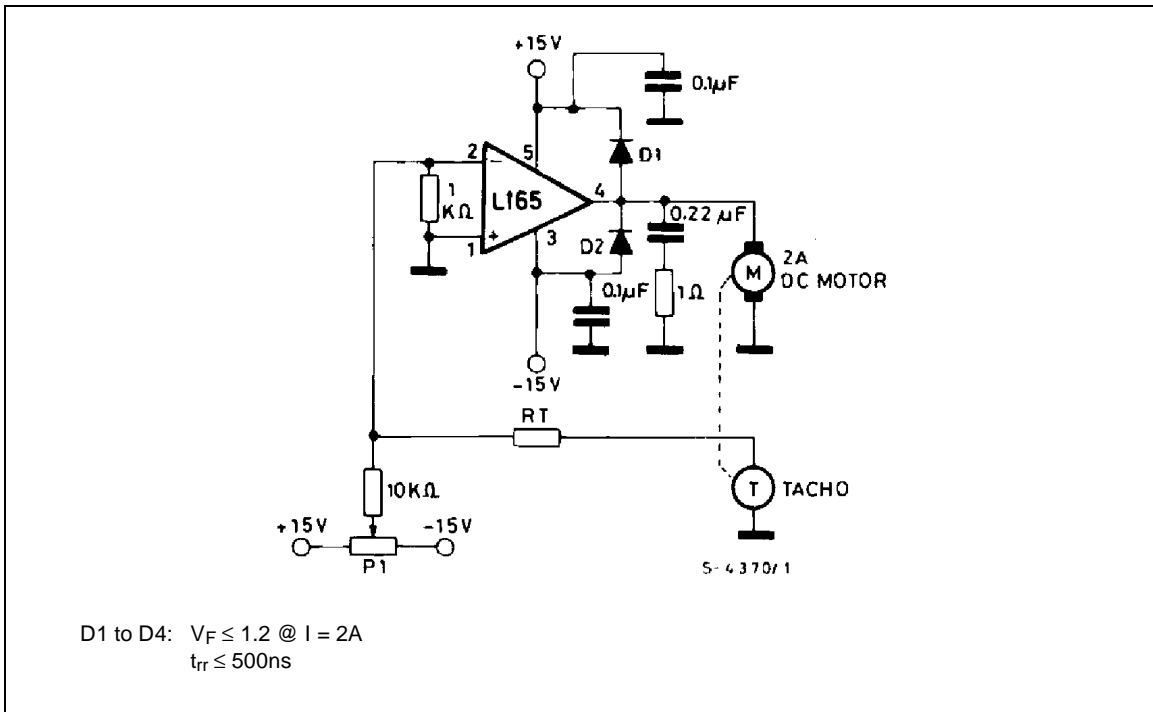

Figure 13. Split power supply.

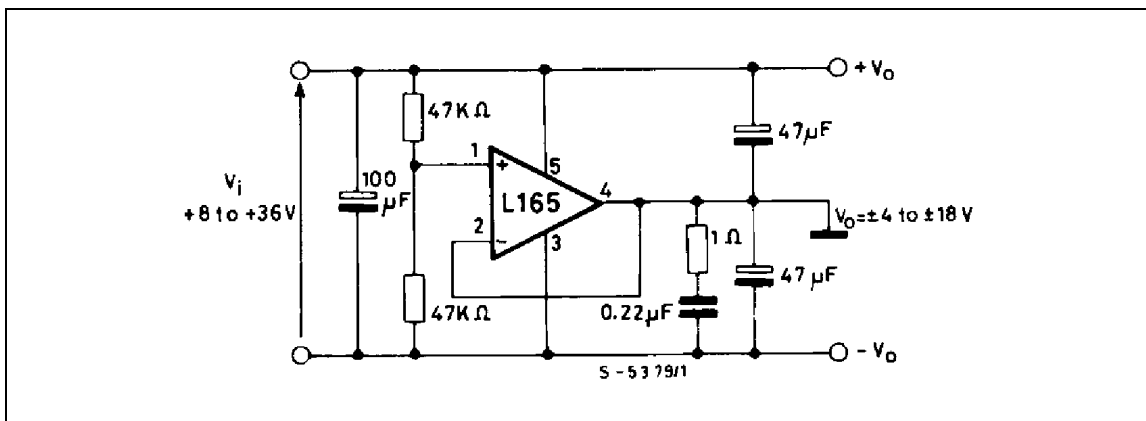
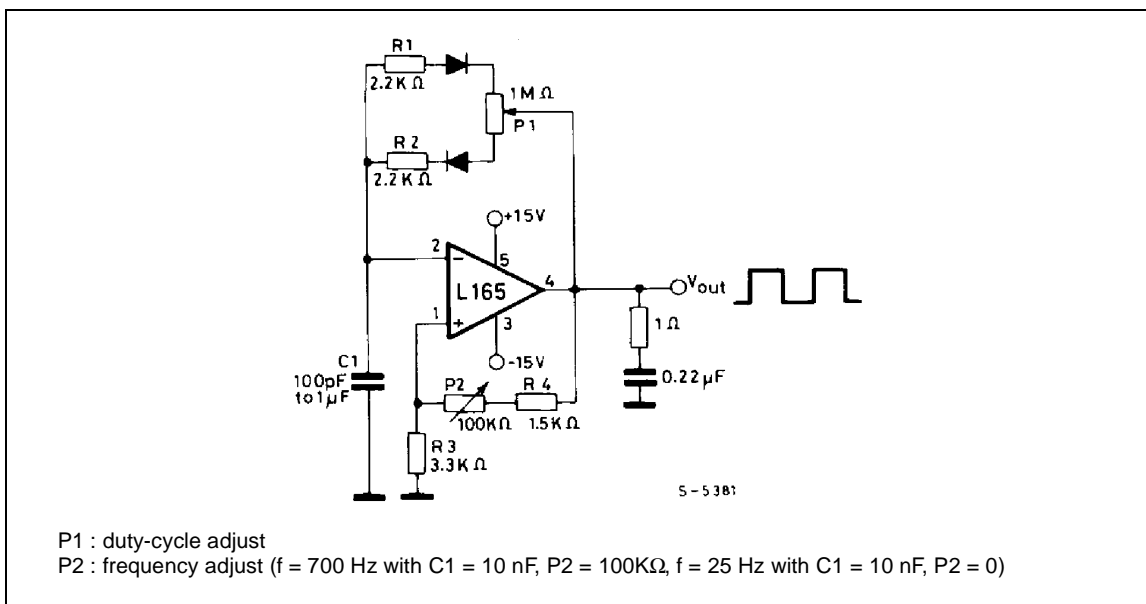

Figure 14. Power squarewave oscillator with independent adjustments for frequency and duty-cycle.



# L165

DIM.	mm			inch		
	MIN.	TYP.	MAX.	MIN.	TYP.	MAX.
A			4.8			0.189
C			1.37			0.054
D	2.4		2.8	0.094		0.110
D1	1.2		1.35	0.047		0.053
E	0.35		0.55	0.014		0.022
E1	0.76		1.19	0.030		0.047
F	0.8		1.05	0.031		0.041
F1	1.0		1.4	0.039		0.055
G	3.2	3.4	3.6	0.126	0.134	0.142
G1	6.6	6.8	7.0	0.260	0.268	0.276
H2			10.4			0.409
H3	10.05		10.4	0.396		0.409
L	17.55	17.85	18.15	0.691	0.703	0.715
L1	15.55	15.75	15.95	0.612	0.620	0.628
L2	21.2	21.4	21.6	0.831	0.843	0.850
L3	22.3	22.5	22.7	0.878	0.886	0.894
L4			1.29			0.051
L5	2.6		3.0	0.102		0.118
L6	15.1		15.8	0.594		0.622
L7	6.0		6.6	0.236		0.260
L9	2.1		2.7	0.008		0.106
L10	4.3		4.8	0.17		0.189
M	4.23	4.5	4.75	0.167	0.178	0.187
M1	3.75	4.0	4.25	0.148	0.157	0.167
V4	40° (typ.)					
V5	90° (typ.)					
Dia	3.65		3.85	0.144		0.152

## OUTLINE AND MECHANICAL DATA

Weight: 2.00gr



## Pentawatt V

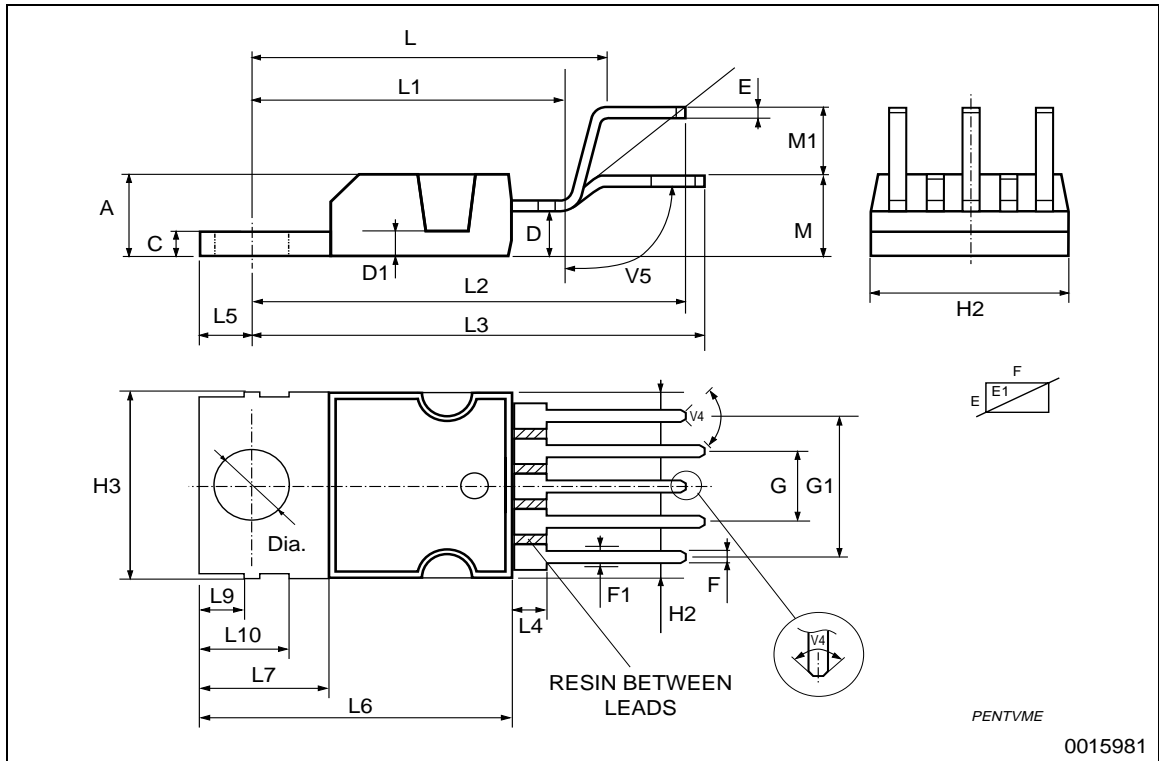



Information furnished is believed to be accurate and reliable. However, STMicroelectronics assumes no responsibility for the consequences of use of such information nor for any infringement of patents or other rights of third parties which may result from its use. No license is granted by implication or otherwise under any patent or patent rights of STMicroelectronics. Specifications mentioned in this publication are subject to change without notice. This publication supersedes and replaces all information previously supplied. STMicroelectronics products are not authorized for use as critical components in life support devices or systems without express written approval of STMicroelectronics.

STMicroelectronics acknowledges the trademarks of all companies referred to in this document.

The ST logo is a registered trademark of STMicroelectronics  
© 2003 STMicroelectronics - All Rights Reserved

STMicroelectronics GROUP OF COMPANIES  
Australia - Brazil - Canada - China - Finland - France - Germany - Hong Kong - India - Israel - Italy - Japan -Malaysia - Malta - Morocco -  
Singapore - Spain - Sweden - Switzerland - United Kingdom - United States.  
<http://www.st.com>

