

## Precision rail-to-rail input/output 3 MHz single operational amplifier

### Features

- Good precision: 800  $\mu$ V max
- Rail-to-rail input and output
- Wide supply voltage range: 2.7 to 12 V
- High-speed (3 MHz, 1 V/ $\mu$ s)
- Low consumption (900  $\mu$ A at 3 V)
- Supply voltage rejection ratio: 85 dB
- Micropackage: SOT23-5

### Applications

- Signal conditioning
- Automotive applications
- Laptop/notebook computers
- Transformer/line drivers
- Personal entertainment (CD players)
- Portable communication (cell phones, pagers)
- Digital-to-analog converter buffers
- Portable headphone speaker drivers

### Description

The TS9511 is a single, precision rail-to-rail operational amplifier whose supply voltage range extends from 2.7 to 12 V.

Its high-precision performance associated with a SOT23-5 package makes it suitable for a wide range of demanding applications, such as industrial, automotive, consumer and computer applications.

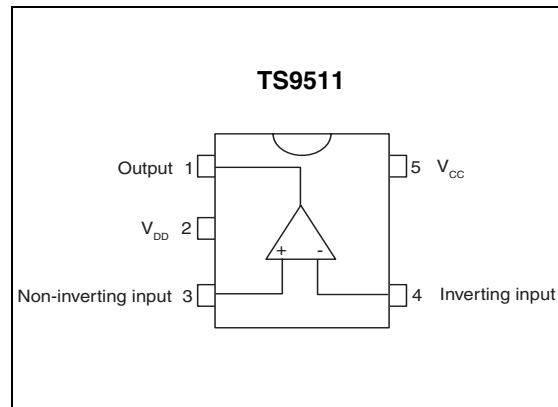

# 1 Absolute maximum ratings and operating conditions

**Table 1. Absolute maximum ratings**

Symbol	Parameter	Value	Unit
$V_{CC}$	Supply voltage <sup>(1)</sup>	14	V
$V_{id}$	Differential input voltage <sup>(2)</sup>	$\pm 1$	V
$V_{in}$	Input voltage <sup>(3)</sup>	$V_{DD}-0.3$ to $V_{CC}+0.3$	V
$T_{stg}$	Storage temperature range	-65 to +150	
$T_j$	Maximum junction temperature	150	°C
$R_{thja}$	Thermal resistance junction to ambient <sup>(4)</sup> SOT23-5	250	°C/W
$R_{thjc}$	Thermal resistance junction to case <sup>(4)</sup> SOT23-5	81	°C/W
ESD	HBM: human body model <sup>(5)</sup>	1	kV
	MM: machine model <sup>(6)</sup>	100	V
	CDM: charged device model <sup>(7)</sup>	1.5	kV
	Latch-up immunity	200	mA
	Lead temperature (soldering, 10sec)	260	°C

- All voltage values, except differential voltage, are with respect to network ground terminal.
- Differential voltages are the non-inverting input terminal with respect to the inverting input terminal. If  $V_{id} > \pm 1$  V, the maximum input current must not exceed  $\pm 1$  mA. In this case ( $V_{id} > \pm 1$  V), an input series resistor must be added to limit input current.
- Do not exceed 14 V.
- Short-circuits can cause excessive heating and destructive dissipation.  $R_{th}$  are typical values.
- Human body model: a 100 pF capacitor is charged to the specified voltage, then discharged through a 1.5 k $\Omega$  resistor between two pins of the device. This is done for all couples of connected pin combinations while the other pins are floating.
- Machine model: a 200 pF capacitor is charged to the specified voltage, then discharged directly between two pins of the device with no external series resistor (internal resistor < 5  $\Omega$ ). This is done for all couples of connected pin combinations while the other pins are floating.
- Charged device model: all pins and the package are charged together to the specified voltage and then discharged directly to the ground through only one pin. This is done for all pins.

**Table 2. Operating conditions**

Symbol	Parameter	Value	Unit
$V_{CC}$	Supply voltage	2.7 to 12	V
$V_{icm}$	Common mode input voltage range	$V_{DD}-0.2$ to $V_{CC}+0.2$	V
$T_{oper}$	Operating free air temperature range	-40 to +125	°C

## 2 Electrical characteristics

Table 3.  $V_{CC} = +3\text{ V}$ ,  $V_{DD} = 0\text{ V}$ ,  $V_{icm} = V_{CC}/2$ ,  $R_L$  connected to  $V_{CC}/2$ ,  $T_{amb} = 25^\circ\text{ C}$   
(unless otherwise specified)

Symbol	Parameter	Min.	Typ.	Max.	Unit
$V_{io}$	Input offset voltage $T_{min} \leq T_{amb} \leq T_{max}$			800 1500	$\mu\text{V}$
$DV_{io}$	Input offset voltage drift		2		$\mu\text{V}/^\circ\text{C}$
$I_{io}$	Input offset current $T_{min} \leq T_{amb} \leq T_{max}$		1	30 80	nA
$I_{ib}$	Input bias current $T_{min} \leq T_{amb} \leq T_{max}$		30	70 150	nA
CMR	Common mode rejection ratio $T_{min} \leq T_{amb} \leq T_{max}$	60 55	90		dB
SVR	Supply voltage rejection ratio, $V_{CC} = 2.7$ to $3.3\text{ V}$ $T_{min} \leq T_{amb} \leq T_{max}$	65 60	90		dB
$A_{vd}$	Large signal voltage gain, $V_o = 2 V_{pk-pk}$ , $R_L = 600\ \Omega$ $T_{min} \leq T_{amb} \leq T_{max}$	70 65	80		dB
$V_{OH}$	High level output voltage, $R_L = 600\ \Omega$ $T_{min} \leq T_{amb} \leq T_{max}$	2.8 2.8	2.9		V
$V_{OL}$	Low level output voltage, $R_L = 600\ \Omega$ $T_{min} \leq T_{amb} \leq T_{max}$		80	250 250	mV
$I_{sc}$	Output short-circuit current	10	20		mA
$I_{CC}$	Supply current (per amplifier), No load, $V_{icm} = V_{CC}/2$ $T_{min} \leq T_{amb} \leq T_{max}$		0.8	1 1.2	mA
GBP	Gain bandwidth product $R_L = 10\text{ k}\Omega$ , $C_L = 100\text{ pF}$		3		MHz
SR	Slew rate $R_L = 10\text{ k}\Omega$ , $C_L = 100\text{ pF}$		1		$\text{V}/\mu\text{s}$
$\phi_m$	Phase margin at unit gain $R_L = 10\text{ k}\Omega$ , $C_L = 100\text{ pF}$		58		Degrees
Gm	Gain margin $R_L = 10\text{ k}\Omega$ , $C_L = 100\text{ pF}$		12		dB
$e_n$	Equivalent input noise voltage $f = 1\text{ kHz}$		25		$\frac{\text{nV}}{\sqrt{\text{Hz}}}$
THD	Total harmonic distortion $V_{out} = 4 V_{pk-pk}$ , $F = 10\text{ kHz}$ , $A_V = 2$ , $R_L = 10\text{ k}\Omega$		0.01		%

**Table 4.**  $V_{CC} = +5\text{ V}$ ,  $V_{DD} = 0\text{ V}$ ,  $V_{icm} = V_{CC}/2$ ,  $R_L$  connected to  $V_{CC}/2$ ,  $T_{amb} = 25^\circ\text{C}$   
(unless otherwise specified)

Symbol	Parameter	Min.	Typ.	Max.	Unit
$V_{io}$	Input offset voltage $T_{min} \leq T_{amb} \leq T_{max}$			800 1500	$\mu\text{V}$
$DV_{io}$	Input offset voltage drift		2		$\mu\text{V}/^\circ\text{C}$
$I_{io}$	Input offset current $V_{icm} = V_{CC}/2$ $T_{min} \leq T_{amb} \leq T_{max}$		1	30 80	nA
$I_{ib}$	Input bias current $T_{min} \leq T_{amb} \leq T_{max}$		30	70 150	nA
CMR	Common mode rejection ratio $T_{min} \leq T_{amb} \leq T_{max}$	60 55	90		dB
SVR	Supply voltage rejection ratio, $V_{CC} = 4$ to $5\text{ V}$ $T_{min} \leq T_{amb} \leq T_{max}$	65 60	90		dB
$A_{vd}$	Large signal voltage gain, $V_o = 2 V_{pk-pk}$ , $R_L = 600\ \Omega$ $T_{min} \leq T_{amb} \leq T_{max}$	75 70	86		dB
$V_{OH}$	High level output voltage, $R_L = 600\ \Omega$ $T_{min} \leq T_{amb} \leq T_{max}$	4.7 4.7	4.8		V
$V_{OL}$	Low level output voltage, $R_L = 600\ \Omega$ $T_{min} \leq T_{amb} \leq T_{max}$		80	300 300	mV
$I_{sc}$	Output short-circuit current	10	20		mA
$I_{CC}$	Supply current (per amplifier), No load, $V_{icm} = V_{CC}/2$ $T_{min} \leq T_{amb} \leq T_{max}$		0.95	1.2 1.3	mA
GBP	Gain bandwidth product $R_L = 10\text{ k}\Omega$ , $C_L = 100\text{ pF}$		3		MHz
SR	Slew rate $R_L = 10\text{ k}\Omega$ , $C_L = 100\text{ pF}$		1		$\text{V}/\mu\text{s}$
$\phi_m$	Phase margin at unit gain $R_L = 10\text{ k}\Omega$ , $C_L = 100\text{ pF}$		61		Degrees
Gm	Gain margin $R_L = 10\text{ k}\Omega$ , $C_L = 100\text{ pF}$		13		dB
$e_n$	Equivalent input noise voltage $f = 1\text{ kHz}$		25		$\frac{\text{nV}}{\sqrt{\text{Hz}}}$
THD	Total harmonic distortion $V_{out} = 4 V_{pk-pk}$ , $F = 10\text{ kHz}$ , $A_V = 2$ , $R_L = 10\text{ k}\Omega$		0.01		%

Figure 1. Supply current vs. supply voltage

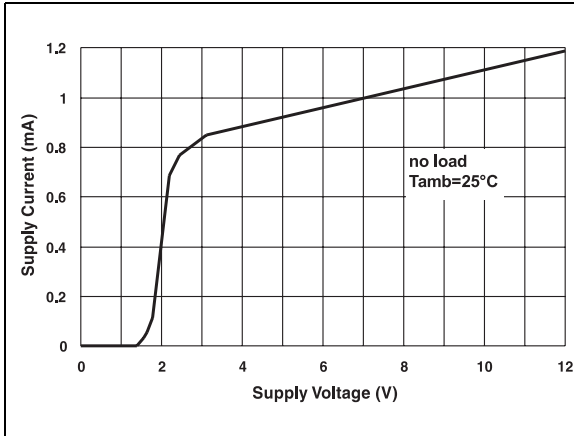

Figure 2. Supply current vs. temperature

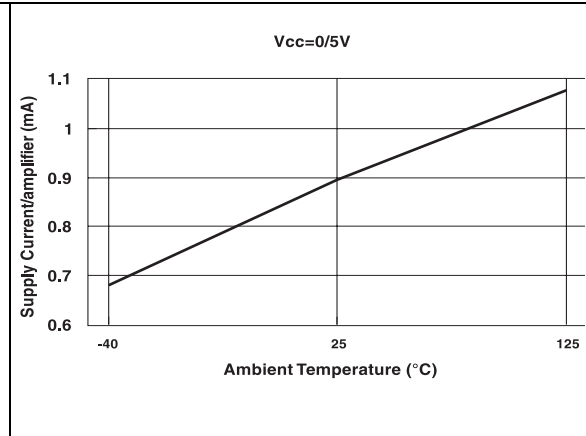

Figure 3. Output short circuit current vs. output voltage

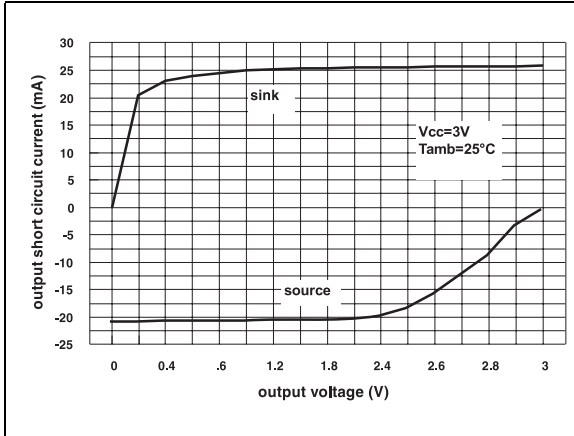

Figure 4. Output short circuit current vs. temperature

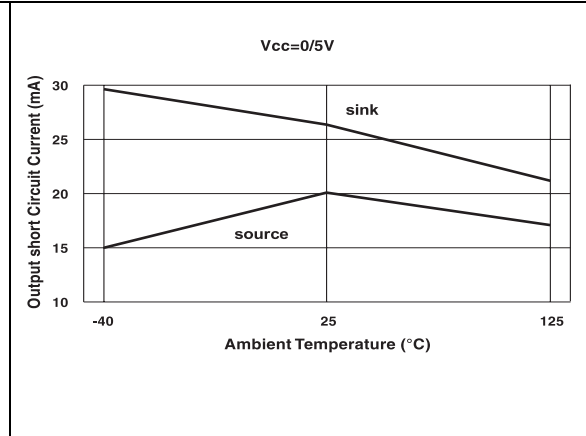

Figure 5. Voltage gain and phase vs. frequency,  $R_L = 600 \Omega$ ,  $C_L = 100 \text{ pF}$

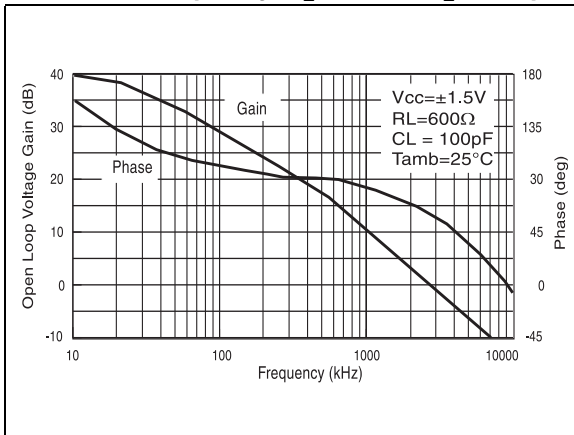

Figure 6. Voltage gain and phase vs. frequency,  $R_L = 10 \text{ k}\Omega$ ,  $C_L = 100 \text{ pF}$

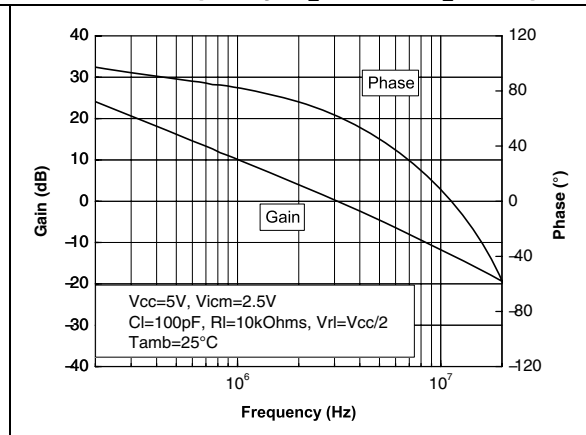

Figure 7. Slew rate vs. temperature

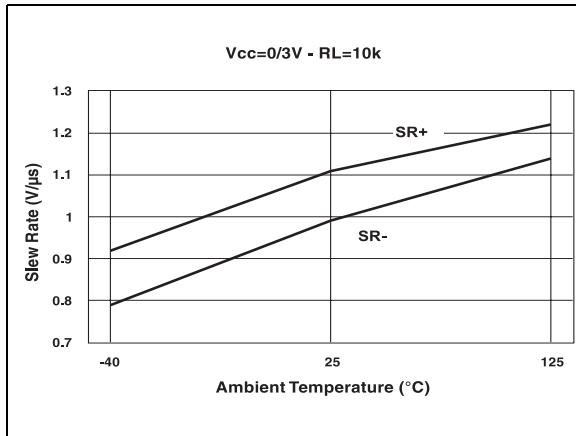

Figure 8. THD + noise vs.  $V_{out}$

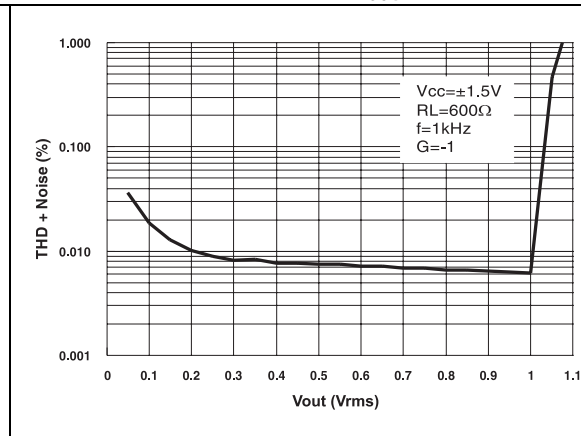

Figure 9. THD + noise vs.  $V_{out}$

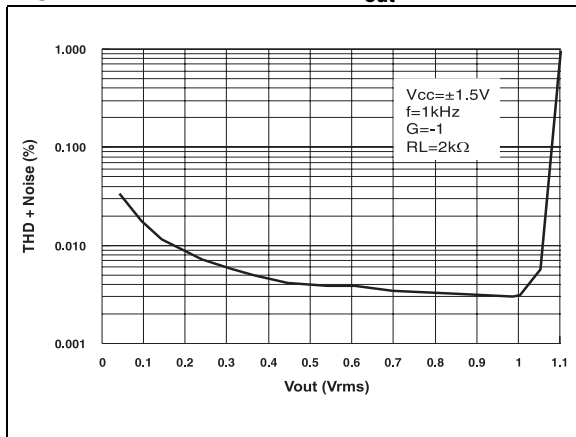

Figure 10. THD + noise vs. frequency

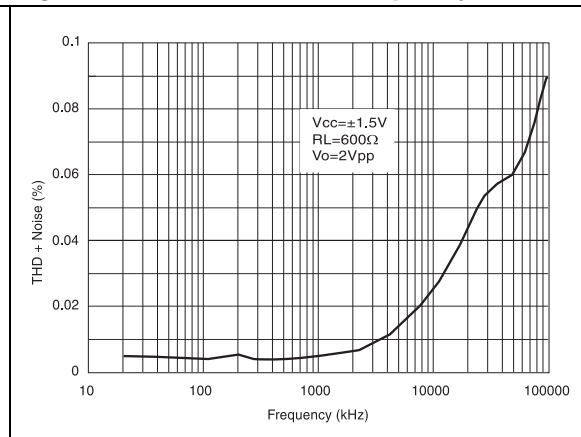
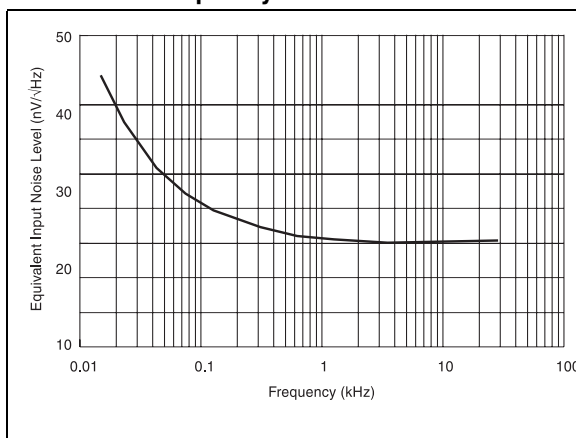

Figure 11. Equivalent input noise voltage vs. frequency



### 3 Package information

In order to meet environmental requirements, ST offers these devices in different grades of ECOPACK<sup>®</sup> packages, depending on their level of environmental compliance. ECOPACK<sup>®</sup> specifications, grade definitions and product status are available at: [www.st.com](http://www.st.com). ECOPACK<sup>®</sup> is an ST trademark.

### 3.1 SOT23-5 package information

Figure 12. SOT23-5 package mechanical drawing

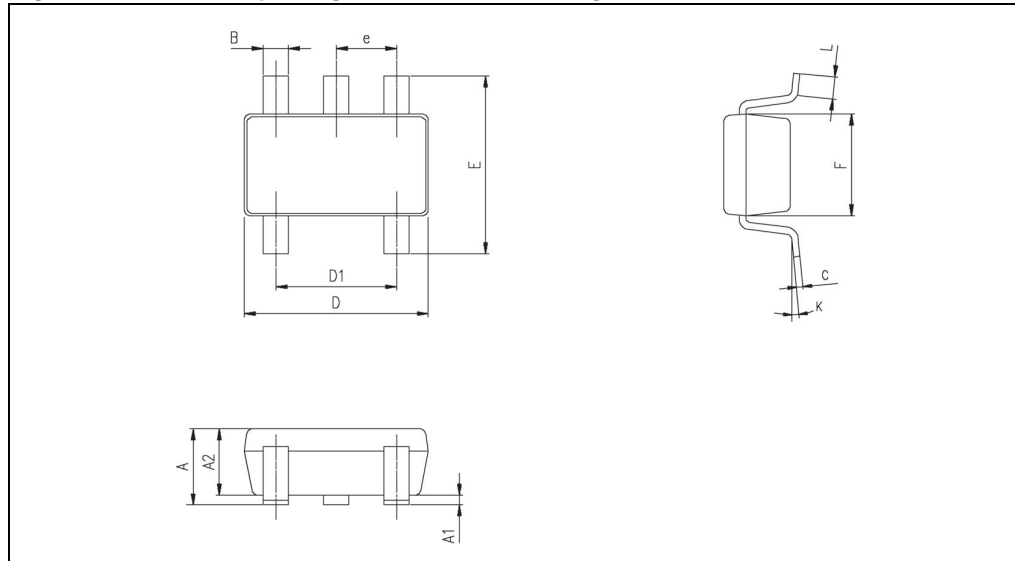

Table 5. SOT23-5 package mechanical data

Ref.	Dimensions					
	Millimeters			Inches		
	Min.	Typ.	Max.	Min.	Typ.	Max.
A	0.90	1.20	1.45	0.035	0.047	0.057
A1			0.15			0.006
A2	0.90	1.05	1.30	0.035	0.041	0.051
B	0.35	0.40	0.50	0.013	0.015	0.019
C	0.09	0.15	0.20	0.003	0.006	0.008
D	2.80	2.90	3.00	0.110	0.114	0.118
D1		1.90			0.075	
e		0.95			0.037	
E	2.60	2.80	3.00	0.102	0.110	0.118
F	1.50	1.60	1.75	0.059	0.063	0.069
L	0.10	0.35	0.60	0.004	0.013	0.023
K	0 degrees		10 degrees			



## 4 Ordering information

Table 6. Order codes

Order code	Temperature range	Package	Packing	Marking
TS9511ILT	-40° C to +125° C	SOT23-5L	Tape & reel	K151
TS9511IYLT <sup>(1)</sup>		SOT23-5L (Automotive grade)		K152

1. Qualification and characterization according to AEC Q100 and Q003 or equivalent, advanced screening according to AEC Q001 & Q 002 or equivalent are on-going.

## 5 Revision history

Table 7. Document revision history

Date	Revision	Changes
25-Jun-2009	1	Initial release.
17-Dec-2009	2	Modified CMR, SVR, $A_{vd}$ , $V_{OH}$ , $V_{OL}$ , $I_{SC}$ and $I_{CC}$ values in <a href="#">Table 3</a> and <a href="#">Table 4</a> .

**Please Read Carefully:**

Information in this document is provided solely in connection with ST products. STMicroelectronics NV and its subsidiaries ("ST") reserve the right to make changes, corrections, modifications or improvements, to this document, and the products and services described herein at any time, without notice.

All ST products are sold pursuant to ST's terms and conditions of sale.

Purchasers are solely responsible for the choice, selection and use of the ST products and services described herein, and ST assumes no liability whatsoever relating to the choice, selection or use of the ST products and services described herein.

No license, express or implied, by estoppel or otherwise, to any intellectual property rights is granted under this document. If any part of this document refers to any third party products or services it shall not be deemed a license grant by ST for the use of such third party products or services, or any intellectual property contained therein or considered as a warranty covering the use in any manner whatsoever of such third party products or services or any intellectual property contained therein.

**UNLESS OTHERWISE SET FORTH IN ST'S TERMS AND CONDITIONS OF SALE ST DISCLAIMS ANY EXPRESS OR IMPLIED WARRANTY WITH RESPECT TO THE USE AND/OR SALE OF ST PRODUCTS INCLUDING WITHOUT LIMITATION IMPLIED WARRANTIES OF MERCHANTABILITY, FITNESS FOR A PARTICULAR PURPOSE (AND THEIR EQUIVALENTS UNDER THE LAWS OF ANY JURISDICTION), OR INFRINGEMENT OF ANY PATENT, COPYRIGHT OR OTHER INTELLECTUAL PROPERTY RIGHT.**

**UNLESS EXPRESSLY APPROVED IN WRITING BY AN AUTHORIZED ST REPRESENTATIVE, ST PRODUCTS ARE NOT RECOMMENDED, AUTHORIZED OR WARRANTED FOR USE IN MILITARY, AIR CRAFT, SPACE, LIFE SAVING, OR LIFE SUSTAINING APPLICATIONS, NOR IN PRODUCTS OR SYSTEMS WHERE FAILURE OR MALFUNCTION MAY RESULT IN PERSONAL INJURY, DEATH, OR SEVERE PROPERTY OR ENVIRONMENTAL DAMAGE. ST PRODUCTS WHICH ARE NOT SPECIFIED AS "AUTOMOTIVE GRADE" MAY ONLY BE USED IN AUTOMOTIVE APPLICATIONS AT USER'S OWN RISK.**

Resale of ST products with provisions different from the statements and/or technical features set forth in this document shall immediately void any warranty granted by ST for the ST product or service described herein and shall not create or extend in any manner whatsoever, any liability of ST.

ST and the ST logo are trademarks or registered trademarks of ST in various countries.

Information in this document supersedes and replaces all information previously supplied.

The ST logo is a registered trademark of STMicroelectronics. All other names are the property of their respective owners.

© 2009 STMicroelectronics - All rights reserved

STMicroelectronics group of companies

Australia - Belgium - Brazil - Canada - China - Czech Republic - Finland - France - Germany - Hong Kong - India - Israel - Italy - Japan - Malaysia - Malta - Morocco - Philippines - Singapore - Spain - Sweden - Switzerland - United Kingdom - United States of America

[www.st.com](http://www.st.com)

