



TSV62x, TSV62xA

Rail-to-rail input/output 29 μ A 420 kHz CMOS operational amplifiers

Features

- Rail-to-rail input and output
- Low power consumption: 29 μ A typ, 36 μ A max
- Low supply voltage: 1.5 – 5.5 V
- Gain bandwidth product: 420 kHz typ
- Unity gain stability
- Low power shutdown mode: 5 nA typ
- Good accuracy: 800 μ V max (A version)
- Low input bias current: 1 pA typ
- Micropackages: MiniSO-8, SOT23-8, MiniSO-10, TSSOP14, TSSOP16
- EMI hardened operational amplifiers
- High tolerance to ESD: 4 kV HBM
- Extended temperature range: -40 to +125° C

Applications

- Battery-powered applications
- Portable devices
- Signal conditioning
- Active filtering
- Medical instrumentation

Description

The TSV622, TSV623, TSV624 and TSV625 dual and quad operational amplifiers offer low voltage, low power operation and rail-to-rail input and output.

The TSV62x series features an excellent speed/power consumption ratio, offering a 420 kHz gain bandwidth product while consuming only 29 μ A at a 5 V supply voltage. These op-amps are unity gain stable for capacitive loads up to 100 pF. They also feature an ultra-low input bias current and low input offset voltage.

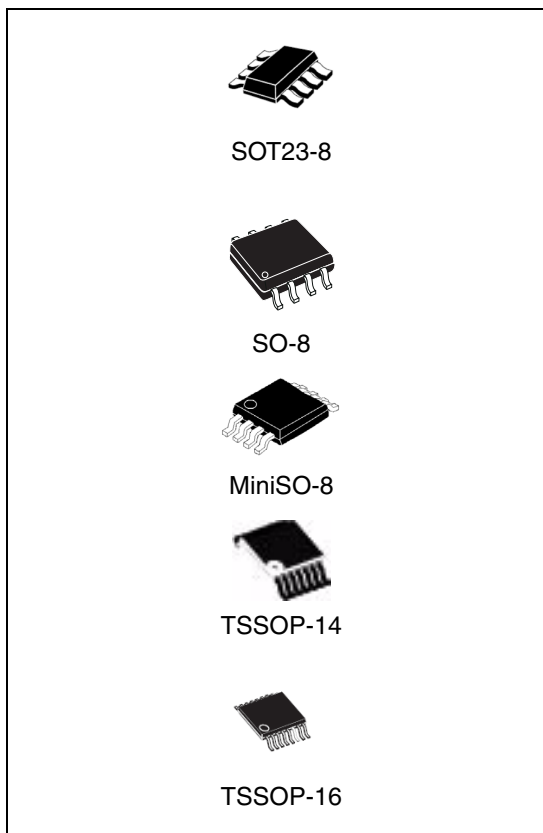

TSV623 (dual) and TSV625 (quad) have two shutdown pins in order to reduce power consumption.

These features make the TSV62x family ideal for sensor interfaces, battery-supplied and portable applications, as well as active filtering.

Table 1. Device summary

Reference	Dual version		Quad version	
	Without standby	With standby	Without standby	With standby
TSV62x	TSV622	TSV623	TSV624	TSV625
TSV62xA	TSV622A	TSV623A	TSV624A	TSV625A

Contents

1	Package pin connections	3
2	Absolute maximum ratings and operating conditions	4
3	Electrical characteristics	5
4	Application information	13
4.1	Operating voltages	13
4.2	Rail-to-rail input	13
4.3	Rail-to-rail output	13
4.4	Optimization of DC and AC parameters	14
4.5	Shutdown function (TSV623, TSV625)	14
4.6	Driving resistive and capacitive loads	15
4.7	PCB layouts	15
4.8	Macromodel	15
5	Package information	16
5.1	SOT23-8 package information	17
5.2	SO-8 package information	18
5.3	MiniSO-8 package information	19
5.4	MiniSO-10 package information	20
5.5	TSSOP14 package information	21
5.6	TSSOP16 package information	22
6	Ordering information	23
7	Revision history	24

1 Package pin connections

Figure 1. Pin connections for each package (top view)

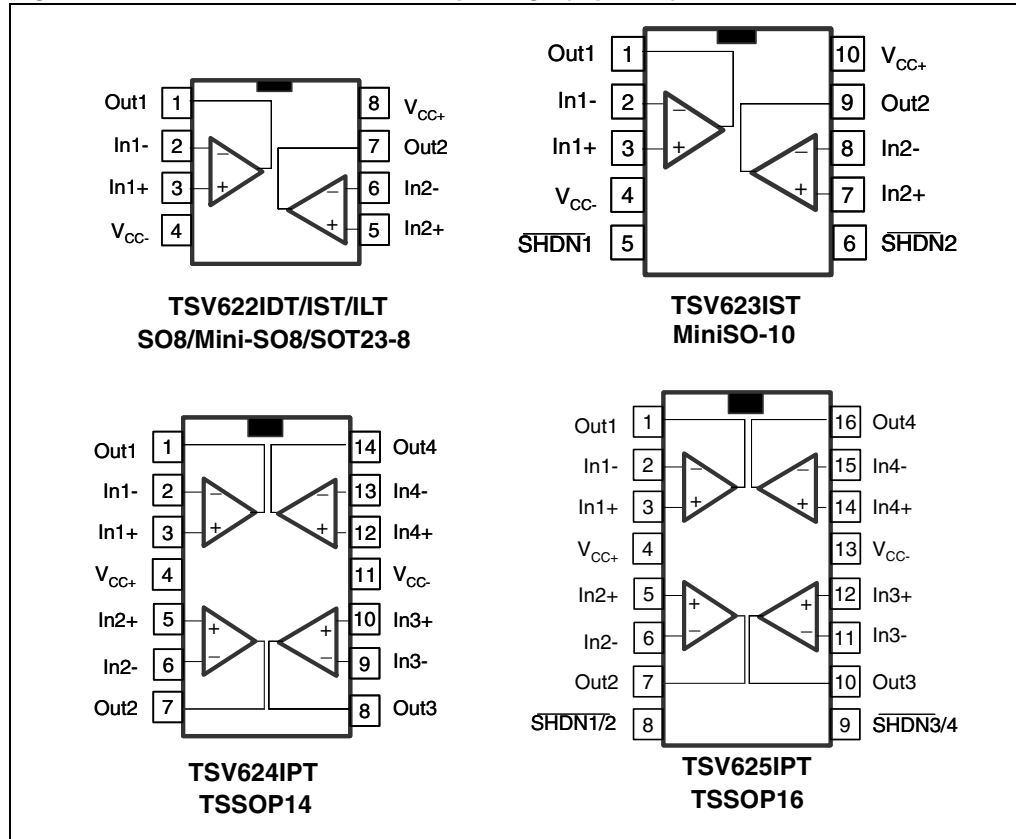

2 Absolute maximum ratings and operating conditions

Table 2. Absolute maximum ratings (AMR)

Symbol	Parameter	Value	Unit
V_{CC}	Supply voltage ⁽¹⁾	6	V
V_{id}	Differential input voltage ⁽²⁾	$\pm V_{CC}$	V
V_{in}	Input voltage ⁽³⁾	$V_{CC-} - 0.2$ to $V_{CC+} + 0.2$	V
I_{in}	Input current ⁽⁴⁾	10	mA
\overline{SHDN}	Shutdown voltage ⁽³⁾	$V_{CC-} - 0.2$ to $V_{CC+} + 0.2$	V
T_{stg}	Storage temperature	-65 to +150	°C
R_{thja}	Thermal resistance junction to ambient ⁽⁵⁾⁽⁶⁾		°C/W
	SOT23-8	105	
	MiniSO-8	190	
	SO-8	125	
	Mini-SO10	113	
	TSSOP14	100	
T_j	Maximum junction temperature	150	°C
ESD	HBM: human body model ⁽⁷⁾	4	kV
	MM: machine model ⁽⁸⁾	200	V
	CDM: charged device model ⁽⁹⁾	1.5	kV
	Latch-up immunity	200	mA

- All voltage values, except differential voltages are with respect to network ground terminal.
- Differential voltages are the non-inverting input terminal with respect to the inverting input terminal.
- $V_{CC-} - V_{in}$ must not exceed 6 V, V_{in} must not exceed 6V.
- Input current must be limited by a resistor in series with the inputs.
- Short-circuits can cause excessive heating and destructive dissipation.
- R_{th} are typical values.
- Human body model: 100 pF discharged through a 1.5 k Ω resistor between two pins of the device, done for all couples of pin combinations with other pins floating.
- Machine model: a 200 pF capacitor is charged to the specified voltage, then discharged directly between two pins of the device with no external series resistor (internal resistor < 5 Ω), done for all couples of pin combinations with other pins floating.
- Charged device model: all pins plus package are charged together to the specified voltage and then discharged directly to ground.

Table 3. Operating conditions

Symbol	Parameter	Value	Unit
V_{CC}	Supply voltage	1.5 to 5.5	V
V_{icm}	Common mode input voltage range	$V_{CC-} - 0.1$ to $V_{CC+} + 0.1$	V
T_{oper}	Operating free air temperature range	-40 to +125	°C

3 Electrical characteristics

Table 4. Electrical characteristics at $V_{CC+} = +1.8\text{ V}$ with $V_{CC-} = 0\text{ V}$, $V_{icm} = V_{CC}/2$, $T_{amb} = 25^\circ\text{ C}$, and R_L connected to $V_{CC}/2$ (unless otherwise specified)

Symbol	Parameter	Conditions	Min.	Typ.	Max.	Unit
DC performance						
V_{io}	Offset voltage	TSV62x			4	mV
		TSV62xA			0.8	
		TSV623AIST - MiniSO10			1	
		TSV62x - $T_{min} < T_{op} < T_{max}$			6	
		TSV62xA - $T_{min} < T_{op} < T_{max}$			2	
		TSV623AIST - $T_{min} < T_{op} < T_{max}$			2.2	
DV_{io}	Input offset voltage drift			2		$\mu\text{V}/^\circ\text{C}$
I_{io}	Input offset current ($V_{out} = V_{CC}/2$)			1	$10^{(1)}$	μA
		$T_{min} < T_{op} < T_{max}$		1	100	μA
I_{ib}	Input bias current ($V_{out} = V_{CC}/2$)			1	$10^{(1)}$	μA
		$T_{min} < T_{op} < T_{max}$		1	100	μA
CMR	Common mode rejection ratio $20 \log (\Delta V_{io}/\Delta V_{io})$	0 V to 1.8 V, $V_{out} = 0.9\text{ V}$	53	74		dB
		$T_{min} < T_{op} < T_{max}$	51			dB
A_{vd}	Large signal voltage gain	$R_L = 10\text{ k}\Omega$, $V_{out} = 0.5\text{ V}$ to 1.3 V	78	95		dB
		$T_{min} < T_{op} < T_{max}$	73			dB
V_{OH}	High level output voltage	$R_L = 10\text{ k}\Omega$ $T_{min} < T_{op} < T_{max}$	35 50	5		mV
V_{OL}	Low level output voltage	$R_L = 10\text{ k}\Omega$ $T_{min} < T_{op} < T_{max}$		4	35 50	mV
I_{out}	Isink	$V_{out} = 1.8\text{ V}$	6	12		mA
		$T_{min} < T_{op} < T_{max}$	4			
	Isource	$V_{out} = 0\text{ V}$	6	10		
		$T_{min} < T_{op} < T_{max}$	4			
I_{CC}	Supply current (per operator)	No load, $V_{out} = V_{CC}/2$		25	31	μA
		$T_{min} < T_{op} < T_{max}$			33	μA
AC performance						
GBP	Gain bandwidth product	$R_L = 10\text{ k}\Omega$, $C_L = 100\text{ pF}$, $f = 100\text{ kHz}$	275	340		kHz
F_u	Unity gain frequency	$R_L = 10\text{ k}\Omega$, $C_L = 100\text{ pF}$,		280		kHz
ϕ_m	Phase margin	$R_L = 10\text{ k}\Omega$, $C_L = 100\text{ pF}$		41		Degrees
G_m	Gain margin	$R_L = 10\text{ k}\Omega$, $C_L = 100\text{ pF}$		8		dB
SR	Slew rate	$R_L = 10\text{ k}\Omega$, $C_L = 100\text{ pF}$, $A_v = 1$	0.1	0.155		$\text{V}/\mu\text{s}$

1. Guaranteed by design.

Table 5. Shutdown characteristics $V_{CC} = 1.8\text{ V}$ (TSV623, TSV625)

Symbol	Parameter	Conditions	Min.	Typ.	Max.	Unit
DC performance						
I_{CC}	Supply current in shutdown mode (all operators)	$\overline{\text{SHDN}} = V_{CC-}$		2.5	50	nA
		$T_{\min} < T_{\text{op}} < 85^\circ\text{ C}$			200	nA
		$T_{\min} < T_{\text{op}} < 125^\circ\text{ C}$			1.5	μA
t_{on}	Amplifier turn-on time	$R_L = 5\text{ k}$, $V_{\text{out}} = V_{CC-}$ to $V_{CC-} + 0.2\text{ V}$		200		ns
t_{off}	Amplifier turn-off time	$R_L = 2\text{ k}$, $V_{\text{out}} = V_{CC+} - 0.5\text{ V}$ to $V_{CC+} - 0.7\text{ V}$		20		ns
V_{IH}	$\overline{\text{SHDN}}$ logic high		1.35			V
V_{IL}	$\overline{\text{SHDN}}$ logic low				0.6	V
I_{IH}	$\overline{\text{SHDN}}$ current high	$\overline{\text{SHDN}} = V_{CC+}$		10		μA
I_{IL}	$\overline{\text{SHDN}}$ current low	$\overline{\text{SHDN}} = V_{CC-}$		10		μA
I_{OLeak}	Output leakage in shutdown mode	$\overline{\text{SHDN}} = V_{CC-}$		50		μA
		$T_{\min} < T_{\text{op}} < 125^\circ\text{ C}$		1		nA

Table 6. $V_{CC+} = +3.3\text{ V}$, $V_{CC-} = 0\text{ V}$, $V_{icm} = V_{CC}/2$, $T_{amb} = 25^\circ\text{ C}$, R_L connected to $V_{CC}/2$
(unless otherwise specified)

Symbol	Parameter	Conditions	Min.	Typ.	Max.	Unit
DC performance						
V_{io}	Offset voltage	TSV62x			4	mV
		TSV62xA			0.8	
		TSV623AIST - MiniSO10			1	
		TSV62x - $T_{min} < T_{op} < T_{max}$			6	
		TSV62xA - $T_{min} < T_{op} < T_{max}$			2	
		TSV623AIST - $T_{min} < T_{op} < T_{max}$			2.2	
DV_{io}	Input offset voltage drift			2		$\mu\text{V}/^\circ\text{C}$
I_{io}	Input offset current			1	$10^{(1)}$	pA
		$T_{min} < T_{op} < T_{max}$		1	100	pA
I_{ib}	Input bias current			1	$10^{(1)}$	pA
		$T_{min} < T_{op} < T_{max}$		1	100	pA
CMR	Common mode rejection ratio $20 \log (\Delta V_{io}/\Delta V_{io})$	0 V to 3.3 V, $V_{out} = 1.65\text{ V}$	57	79		dB
		$T_{min} < T_{op} < T_{max}$	53			dB
A_{vd}	Large signal voltage gain	$R_L = 10\text{ k}\Omega$, $V_{out} = 0.5\text{ V to } 2.8\text{ V}$	81	98		dB
		$T_{min} < T_{op} < T_{max}$	76			dB
V_{OH}	High level output voltage	$R_L = 10\text{ k}\Omega$ $T_{min} < T_{op} < T_{max}$	35 50	5		mV
V_{OL}	Low level output voltage	$R_L = 10\text{ k}\Omega$ $T_{min} < T_{op} < T_{max}$		4	35 50	mV
I_{out}	Isink	$V_o = 5\text{ V}$	23	45		mA
		$T_{min} < T_{op} < T_{max}$	20			
	Isource	$V_o = 0\text{ V}$	23	38		mA
		$T_{min} < T_{op} < T_{max}$	20			
I_{CC}	Supply current (per operator)	No load, $V_{out} = 2.5\text{ V}$		26	33	μA
		$T_{min} < T_{op} < T_{max}$			35	μA
AC performance						
GBP	Gain bandwidth product	$R_L = 10\text{ k}\Omega$, $C_L = 100\text{ pF}$, $f = 100\text{ kHz}$	310	380		kHz
F_u	Unity gain frequency	$R_L = 10\text{ k}\Omega$, $C_L = 100\text{ pF}$		310		kHz
ϕ_m	Phase margin	$R_L = 10\text{ k}\Omega$, $C_L = 100\text{ pF}$		41		Degrees
G_m	Gain margin	$R_L = 10\text{ k}\Omega$, $C_L = 100\text{ pF}$		8		dB
SR	Slew rate	$R_L = 10\text{ k}\Omega$, $C_L = 100\text{ pF}$, $A_V = 1$	0.11	0.175		$\text{V}/\mu\text{s}$

1. Guaranteed by design.

Table 7. $V_{CC+} = +5\text{ V}$, $V_{CC-} = 0\text{ V}$, $V_{icm} = V_{CC}/2$, $T_{amb} = 25^\circ\text{ C}$, R_L connected to $V_{CC}/2$
(unless otherwise specified)

Symbol	Parameter	Conditions	Min.	Typ.	Max.	Unit
DC performance						
V_{io}	Offset voltage	TSV62x			4	mV
		TSV62xA			0.8	
		TSV623AIST - MiniSO10			1	
		TSV62x - $T_{min} < T_{op} < T_{max}$ TSV62xA - $T_{min} < T_{op} < T_{max}$ TSV62xA - $T_{min} < T_{op} < T_{max}$			6 2 2.2	
DV_{io}	Input offset voltage drift		2		$\mu\text{V}/^\circ\text{C}$	
I_{io}	Input offset current			1	$10^{(1)}$	pA
		$T_{min} < T_{op} < T_{max}$		1	100	pA
I_{ib}	Input bias current			1	$10^{(1)}$	pA
		$T_{min} < T_{op} < T_{max}$		1	100	pA
CMR	Common mode rejection ratio $20 \log (\Delta V_{ic}/\Delta V_{io})$	$0\text{ V to }5\text{ V}$, $V_{out} = 2.5\text{ V}$	60	80		dB
		$T_{min} < T_{op} < T_{max}$	55			
A_{vd}	Large signal voltage gain	$R_L = 10\text{ k}\Omega$, $V_{out} = 0.5\text{ V to }4.5\text{ V}$	85	98		dB
		$T_{min} < T_{op} < T_{max}$	80			
SVR	Supply voltage rejection ratio $20 \log (\Delta V_{CC}/\Delta V_{io})$	$V_{CC} = 1.8\text{ to }5\text{ V}$	75	102		dB
		$T_{min} < T_{op} < T_{max}$	73			
EMIRR	EMI rejection ratio EMIRR = $-20 \log (V_{RFpeak}/\Delta V_{io})$	$V_{RF} = 100\text{ mV}_{rms}$, $f = 400\text{ MHz}$		61		dB
		$V_{RF} = 100\text{ mV}_{rms}$, $f = 900\text{ MHz}$		85		
		$V_{RF} = 100\text{ mV}_{rms}$, $f = 1800\text{ MHz}$		92		
		$V_{RF} = 100\text{ mV}_{rms}$, $f = 2400\text{ MHz}$		83		
V_{OH}	High level output voltage	$R_L = 10\text{ k}\Omega$	35	7		mV
		$T_{min} < T_{op} < T_{max}$	50			
V_{OL}	Low level output voltage	$R_L = 10\text{ k}\Omega$		6	35	mV
		$T_{min} < T_{op} < T_{max}$			50	
I_{out}	I_{sink}	$V_o = 5\text{ V}$	40	69		mA
		$T_{min} < T_{op} < T_{max}$	35			
	I_{source}	$V_o = 0\text{ V}$	40	74		mA
		$T_{min} < T_{op} < T_{max}$	35			
I_{CC}	Supply current (per operator)	No load, $V_{out} = 2.5\text{ V}$		29	36	μA
		$T_{min} < T_{op} < T_{max}$			38	μA
AC performance						
GBP	Gain bandwidth product	$R_L = 10\text{ k}\Omega$, $C_L = 100\text{ pF}$, $f = 100\text{ kHz}$	350	420		kHz
F_u	Unity gain frequency	$R_L = 10\text{ k}\Omega$, $C_L = 100\text{ pF}$		360		kHz

Table 7. $V_{CC+} = +5\text{ V}$, $V_{CC-} = 0\text{ V}$, $V_{icm} = V_{CC}/2$, $T_{amb} = 25^\circ\text{ C}$, R_L connected to $V_{CC}/2$
(unless otherwise specified) (continued)

Symbol	Parameter	Conditions	Min.	Typ.	Max.	Unit
ϕ_m	Phase margin	$R_L = 10\text{ k}\Omega$, $C_L = 100\text{ pF}$		40		Degrees
G_m	Gain margin	$R_L = 10\text{ k}\Omega$, $C_L = 100\text{ pF}$		8		dB
SR	Slew rate	$R_L = 10\text{ k}\Omega$, $C_L = 100\text{ pF}$, $A_V = 1$	0.12	0.19		V/ μs
e_n	Equivalent input noise voltage	$f = 1\text{ kHz}$		77		$\frac{\text{nV}}{\sqrt{\text{Hz}}}$
THD+ e_n	Total harmonic distortion + noise	$A_V = 1$, $f = 1\text{ kHz}$, $R_L = 100\text{ k}\Omega$, $V_{icm} = V_{CC}/2$, $V_{out} = 2\text{ V}_{pp}$		0.002		%

1. Guaranteed by design.

Table 8. Shutdown characteristics at $V_{CC} = 5\text{ V}$ (TSV623, TSV625)

Symbol	Parameter	Conditions	Min.	Typ.	Max.	Unit
DC performance						
I_{CC}	Supply current in shutdown mode (all operators)	$\overline{\text{SHDN}} = V_{IL}$		5	50	nA
		$T_{min} < T_{op} < 85^\circ\text{ C}$			200	nA
		$T_{min} < T_{op} < 125^\circ\text{ C}$			1.5	μA
t_{on}	Amplifier turn-on time	$R_L = 5\text{ k}\Omega$, $V_{out} = V_{CC-}$ to $V_{CC-} + 0.2\text{ V}$		200		ns
t_{off}	Amplifier turn-off time	$R_L = 5\text{ k}\Omega$, $V_{out} = V_{CC+} - 0.5\text{ V}$ to $V_{CC+} - 0.7\text{ V}$		20		ns
V_{IH}	$\overline{\text{SHDN}}$ logic high		2			V
V_{IL}	$\overline{\text{SHDN}}$ logic low				0.8	V
I_{IH}	$\overline{\text{SHDN}}$ current high	$\overline{\text{SHDN}} = V_{CC+}$		10		μA
I_{IL}	$\overline{\text{SHDN}}$ current low	$\overline{\text{SHDN}} = V_{CC-}$		10		μA
I_{OLeak}	Output leakage in shutdown mode	$\overline{\text{SHDN}} = V_{CC-}$		50		μA
		$T_{min} < T_{op} < 125^\circ\text{ C}$		1		nA

Figure 2. Supply current vs. supply voltage at $V_{icm} = V_{CC}/2$

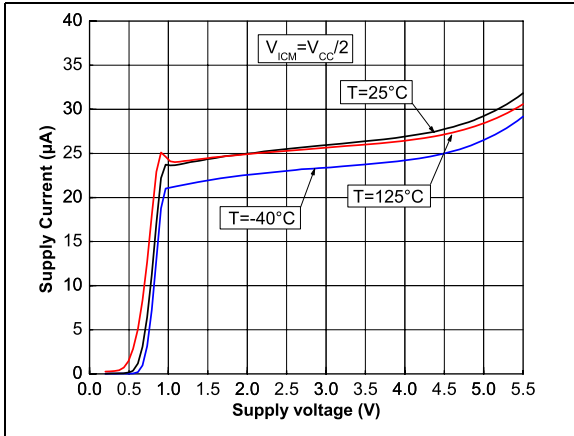

Figure 3. Output current vs. output voltage at $V_{CC} = 1.5 V$

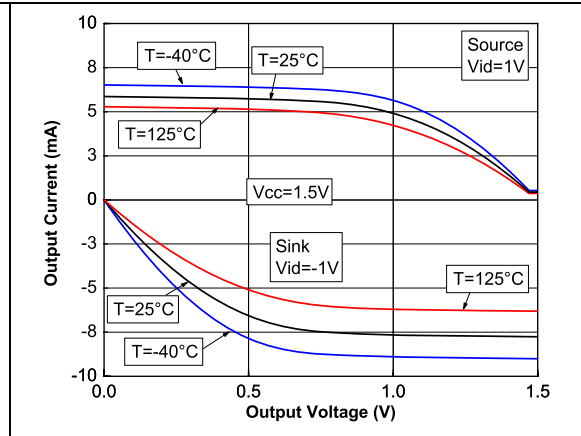

Figure 4. Output current vs. output voltage at $V_{CC} = 5 V$

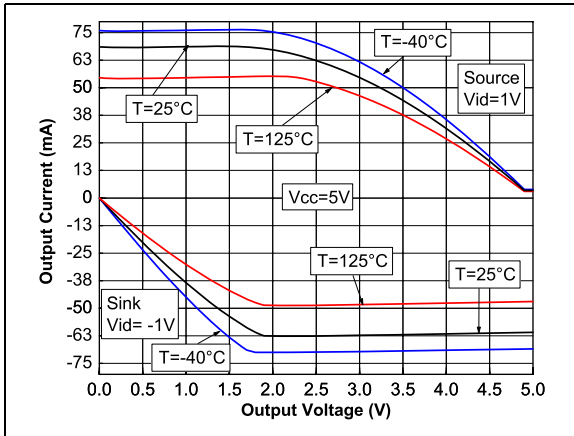

Figure 5. Voltage gain and phase vs. frequency at $V_{CC} = 1.5 V$

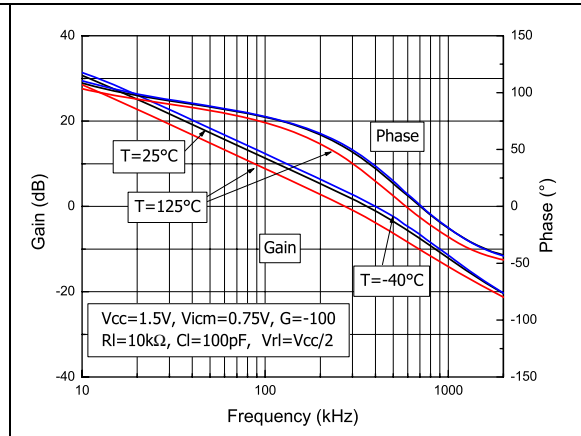

Figure 6. Voltage gain and phase vs. frequency at $V_{CC} = 5 V$

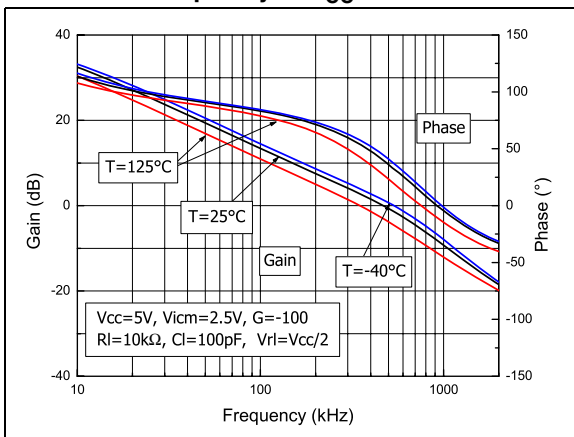

Figure 7. Phase margin vs. output current at $V_{CC} = 1.5 V$ and $V_{CC} = 5 V$

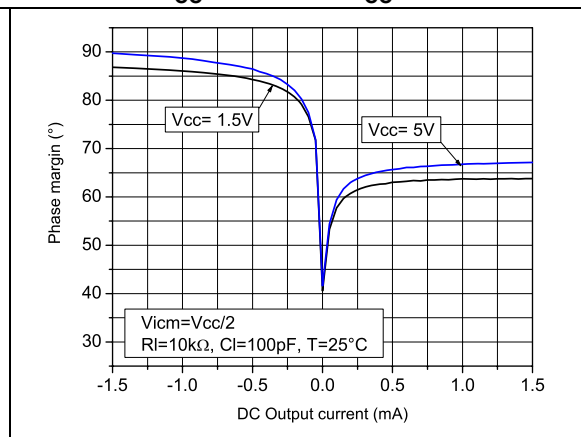

Figure 8. Positive slew rate vs. time

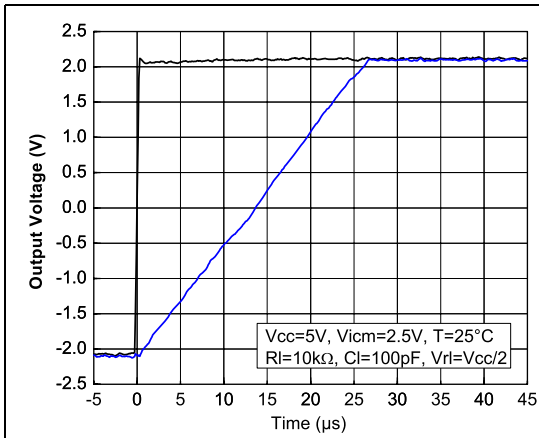

Figure 9. Negative slew rate vs. time

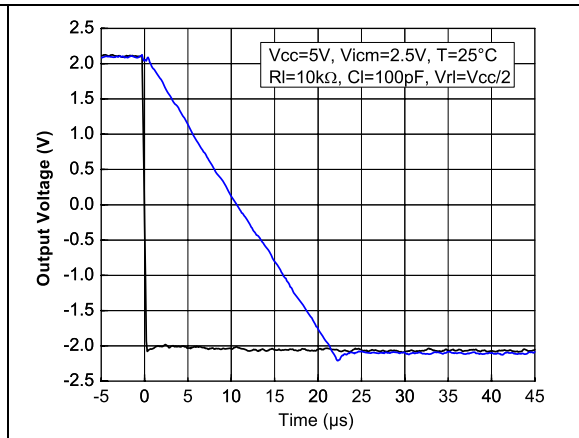

Figure 10. Positive slew rate vs. supply voltage

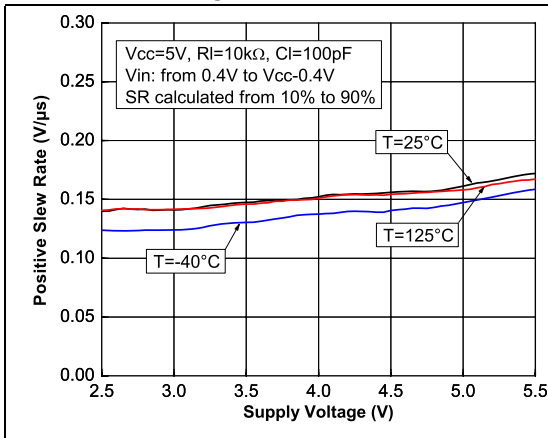

Figure 11. Negative slew rate vs. supply voltage

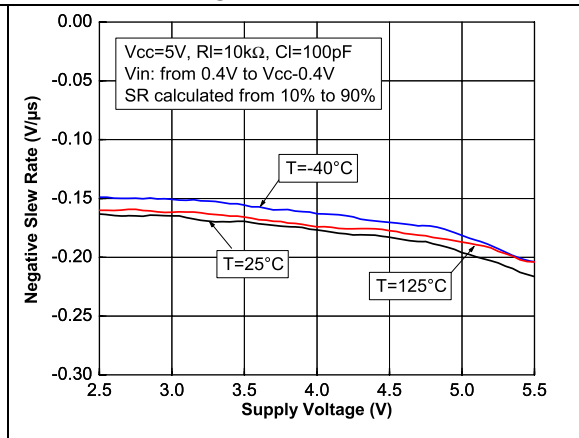

Figure 12. Noise vs. frequency

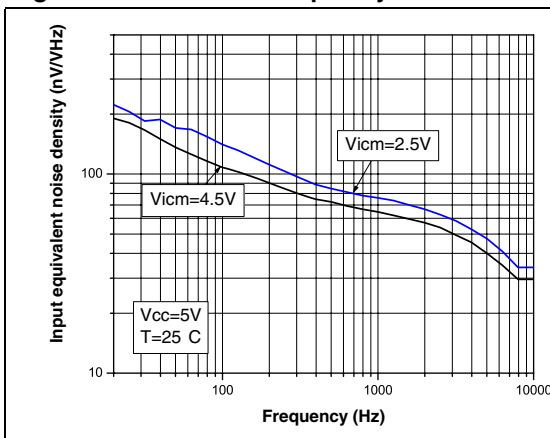

Figure 13. Distortion + noise vs. frequency

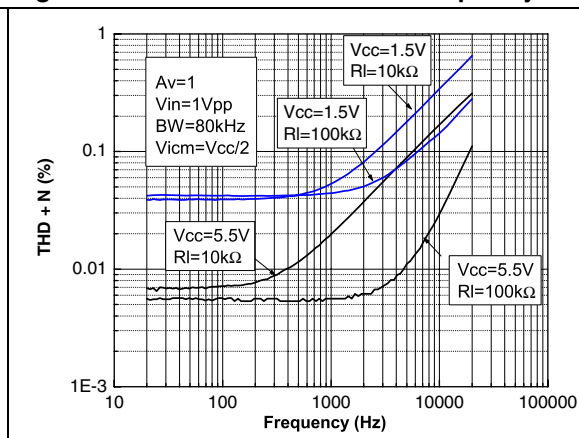

Figure 14. Distortion + noise vs. output voltage

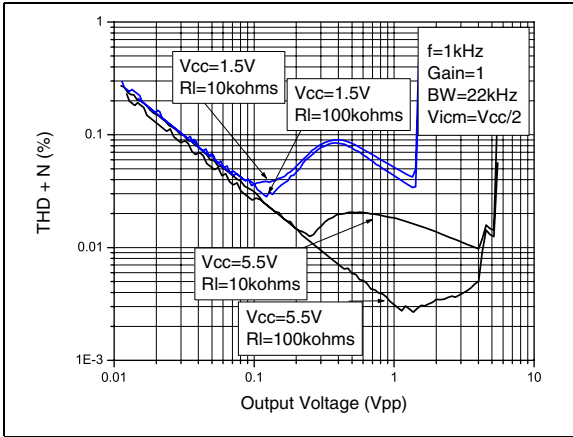
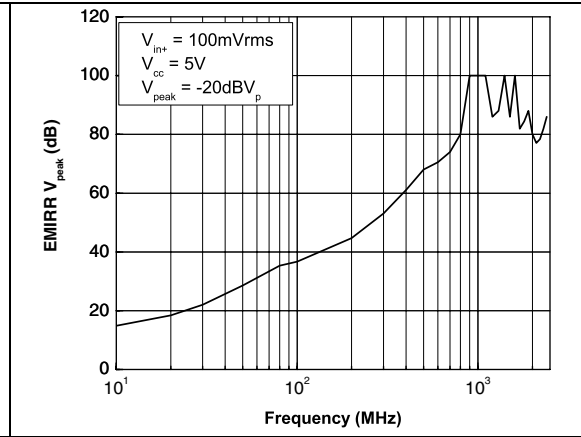

Figure 15. EMIRR vs. frequency at VCC = 5 V, T = 25° C



4 Application information

4.1 Operating voltages

The TSV62x can operate from 1.5 to 5.5 V. Their parameters are fully specified for 1.8-, 3.3- and 5-V power supplies. However, the parameters are very stable in the full V_{CC} range and several characterization curves show the TSV62x characteristics at 1.5 V. Additionally, the main specifications are guaranteed in extended temperature ranges from -40°C to $+125^{\circ}\text{C}$.

4.2 Rail-to-rail input

The TSV62x are built with two complementary PMOS and NMOS input differential pairs. The devices have a rail-to-rail input, and the input common mode range is extended from $V_{CC-} - 0.1\text{ V}$ to $V_{CC+} + 0.1\text{ V}$. The transition between the two pairs appears at $V_{CC+} - 0.7\text{ V}$. In the transition region, the performance of CMRR, PSRR, V_{iO} (Figure 16 and Figure 17) and THD is slightly degraded.

Figure 16. Input offset voltage vs input common mode at $V_{CC} = 1.5\text{ V}$

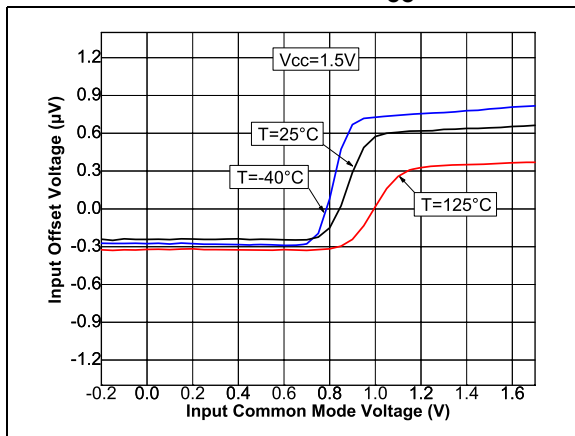
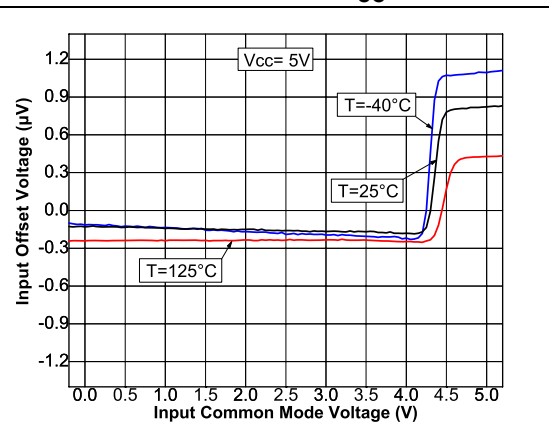

Figure 17. Input offset voltage vs input common mode at $V_{CC} = 5\text{ V}$



The devices are guaranteed without phase reversal.

4.3 Rail-to-rail output

The operational amplifier's output level can go close to the rails: 35 mV maximum above and below the rail when connected to a $10\text{ k}\Omega$ resistive load to $V_{CC}/2$.

4.4 Optimization of DC and AC parameters

These devices use an innovative approach to reduce the spread of the main DC and AC parameters. An internal adjustment achieves a very narrow spread of current consumption (29 μA typical, min/max at $\pm 17\%$). Parameters linked to the current consumption value, such as GBP, SR and AVd benefit from this narrow dispersion. All parts present a similar speed and the same behavior in terms of stability. In addition, the minimum values of GBP and SR are guaranteed (GBP = 350 kHz min, SR = 0.12 V/ μs min).

4.5 Shutdown function (TSV623, TSV625)

The operational amplifier is enabled when the $\overline{\text{SHDN}}$ pin is pulled high. To disable the amplifier, the $\overline{\text{SHDN}}$ must be pulled down to $V_{\text{CC-}}$. When in shutdown mode, the amplifier output is in a high impedance state. The $\overline{\text{SHDN}}$ pin must never be left floating but tied to $V_{\text{CC+}}$ or $V_{\text{CC-}}$. The turn-on and turn-off times are calculated for an output variation of ± 200 mV (Figure 18 and Figure 19 show the test configurations).

Figure 18. Test configuration for turn-on time (Vout pulled down)

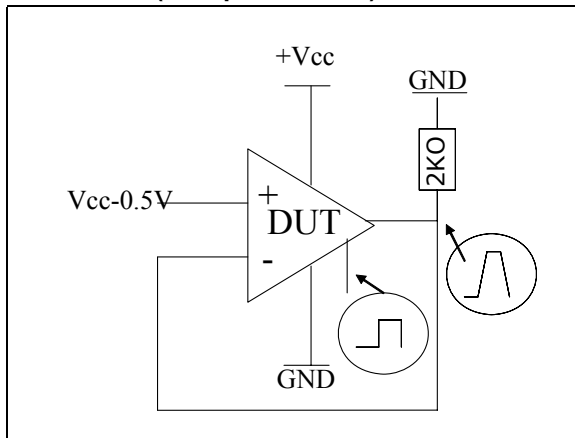

Figure 19. Test configuration for turn-off time (Vout pulled down)

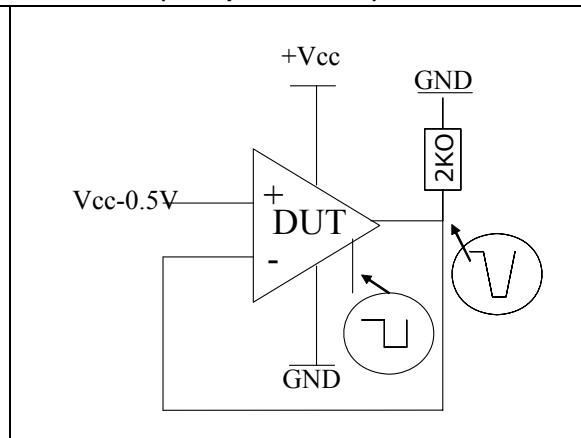

Figure 20. Turn-on time, $V_{\text{CC}} = 5$ V, Vout pulled down, $T = 25^\circ\text{C}$

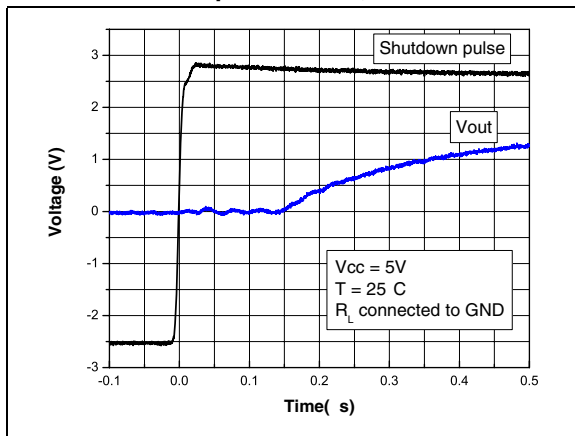
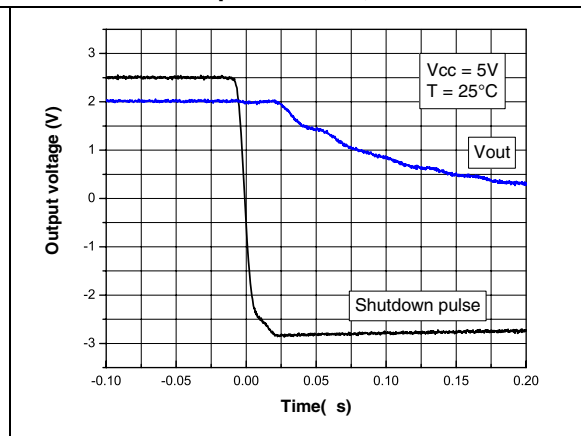

Figure 21. Turn-off time, $V_{\text{CC}} = 5$ V, Vout pulled down, $T = 25^\circ\text{C}$



4.6 Driving resistive and capacitive loads

These products are micro-power, low-voltage operational amplifiers optimized to drive rather large resistive loads, above 5 k Ω . For lower resistive loads, the THD level may significantly increase.

In a *follower* configuration, these operational amplifiers can drive capacitive loads up to 100 pF with no oscillations. When driving larger capacitive loads, adding a small resistor in series at the output can improve the stability of the device (see [Figure 22](#) for recommended in-series resistor values). Once the value of the in-series resistor has been selected, the stability of the circuit should be tested on bench and simulated with the simulation model.

Figure 22. In-series resistor vs. capacitive load

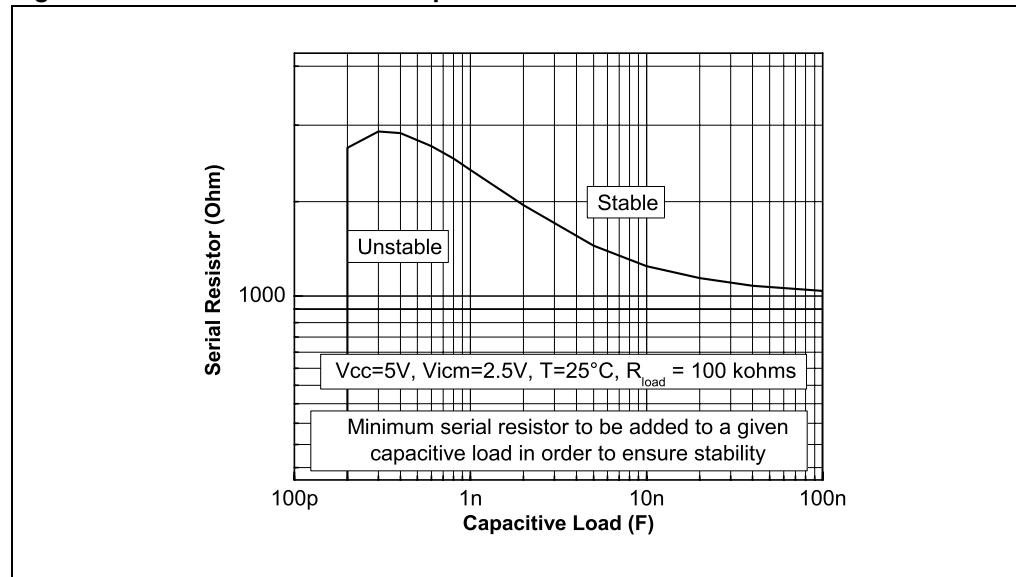

4.7 PCB layouts

For correct operation, it is advised to add 10 nF decoupling capacitors as close as possible to the power supply pins.

4.8 Macromodel

Two accurate macromodels (with or without shutdown feature) of TSV62x are available on STMicroelectronics' web site at www.st.com. This model is a trade-off between accuracy and complexity (that is, time simulation) of the TSV62x operational amplifiers. It emulates the nominal performances of a typical device within the specified operating conditions mentioned in the datasheet. It helps to validate a design approach and to select the right operational amplifier, *but it does not replace on-board measurements*.

5 Package information

In order to meet environmental requirements, ST offers these devices in different grades of ECOPACK[®] packages, depending on their level of environmental compliance. ECOPACK[®] specifications, grade definitions and product status are available at: www.st.com. ECOPACK[®] is an ST trademark.

5.1 SOT23-8 package information

Figure 23. SOT23-8 package mechanical drawing

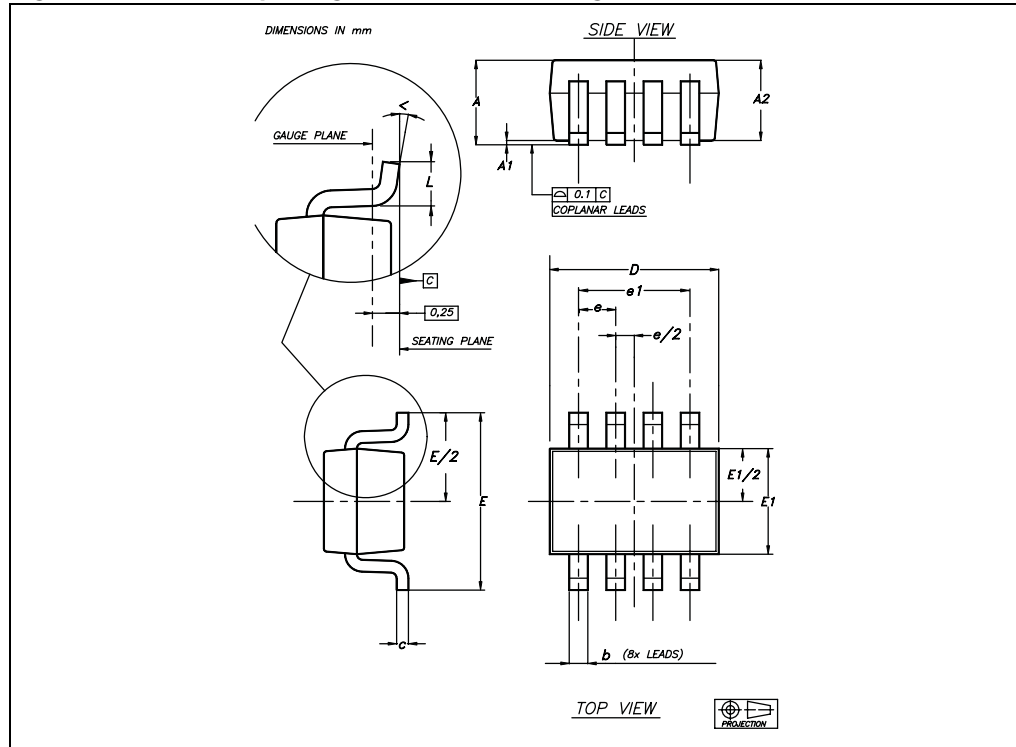

Table 9. SOT23-8 package mechanical data

Ref.	Dimensions					
	Millimeters			Inches		
	Min.	Typ.	Max.	Min.	Typ.	Max.
A			1.45			0.057
A1			0.15			0.006
A2	0.90		1.30	0.035		0.051
b	0.22		0.38	0.009		0.015
c	0.08		0.22	0.003		0.009
D	2.80		3	0.110		0.118
E	2.60		3	0.102		0.118
E1	1.50		1.75	0.059		0.069
e		0.65			0.026	
e1		1.95			0.077	
L	0.30		0.60	0.012		0.024
<	0°		8°			

5.2 SO-8 package information

Figure 24. SO-8 package mechanical drawing

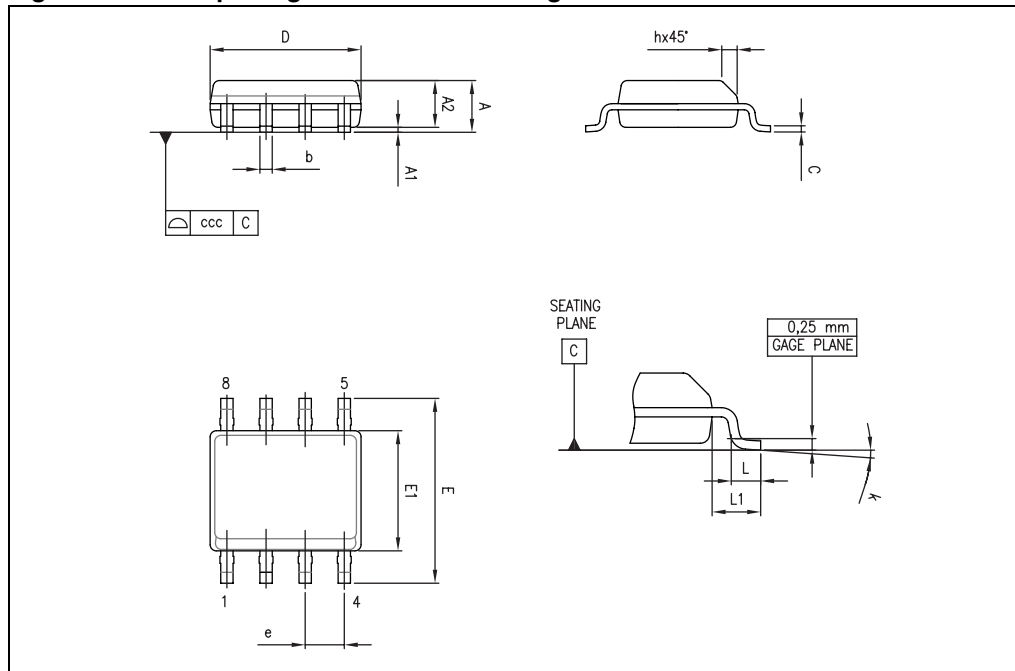

Table 10. SO-8 package mechanical data

Ref.	Dimensions					
	Millimeters			Inches		
	Min.	Typ.	Max.	Min.	Typ.	Max.
A			1.75			0.069
A1	0.10		0.25	0.004		0.010
A2	1.25			0.049		
b	0.28		0.48	0.011		0.019
c	0.17		0.23	0.007		0.010
D	4.80	4.90	5.00	0.189	0.193	0.197
E	5.80	6.00	6.20	0.228	0.236	0.244
E1	3.80	3.90	4.00	0.150	0.154	0.157
e		1.27			0.050	
h	0.25		0.50	0.010		0.020
L	0.40		1.27	0.016		0.050
L1		1.04			0.040	
k	0		8°	1°		8°
ccc			0.10			0.004

5.3 MiniSO-8 package information

Figure 25. MiniSO-8 package mechanical drawing

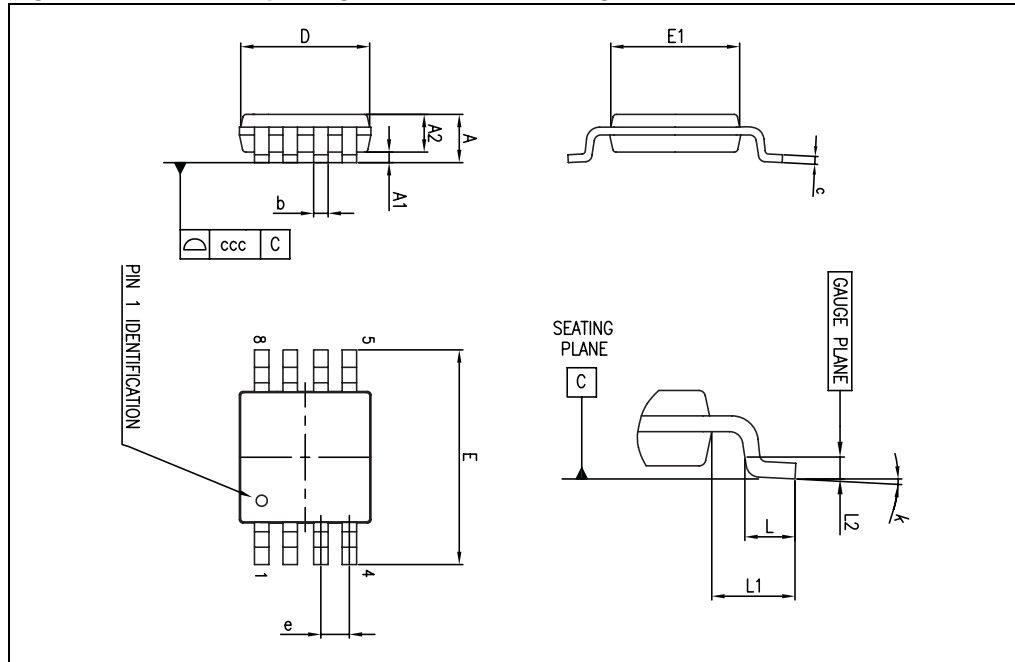

Table 11. MiniSO-8 package mechanical data

Ref.	Dimensions					
	Millimeters			Inches		
	Min.	Typ.	Max.	Min.	Typ.	Max.
A			1.1			0.043
A1	0		0.15	0		0.006
A2	0.75	0.85	0.95	0.030	0.033	0.037
b	0.22		0.40	0.009		0.016
c	0.08		0.23	0.003		0.009
D	2.80	3.00	3.20	0.11	0.118	0.126
E	4.65	4.90	5.15	0.183	0.193	0.203
E1	2.80	3.00	3.10	0.11	0.118	0.122
e		0.65			0.026	
L	0.40	0.60	0.80	0.016	0.024	0.031
L1		0.95			0.037	
L2		0.25			0.010	
k	0°		8°	0°		8°
ccc			0.10			0.004

5.4 MiniSO-10 package information

Figure 26. MiniSO-10 package mechanical drawing

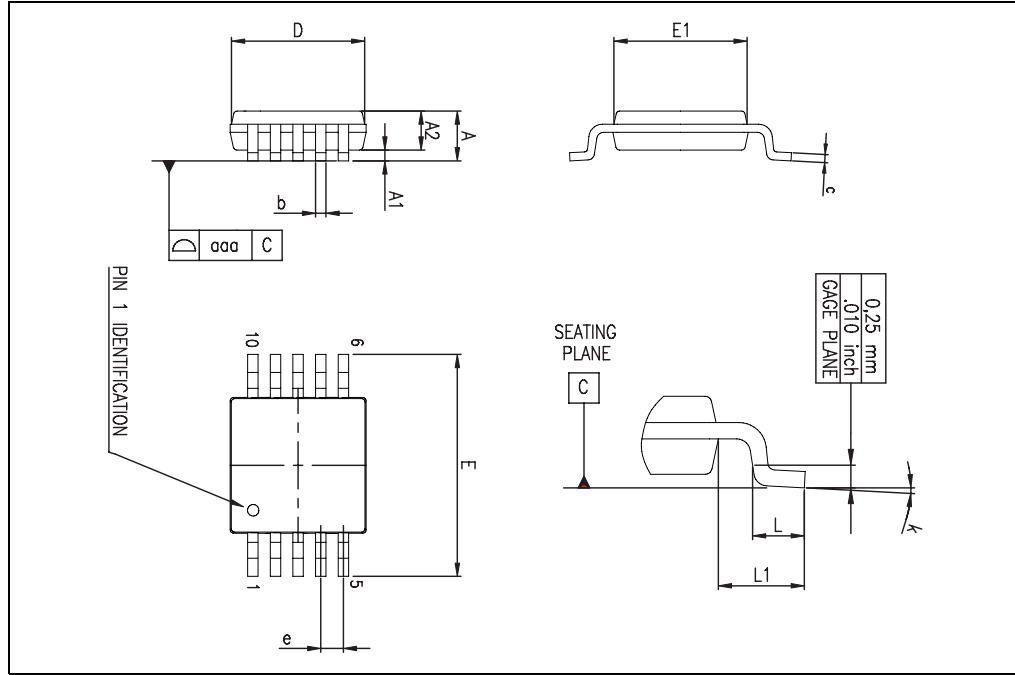

Table 12. MiniSO-10 package mechanical data

Ref.	Dimensions					
	Millimeters			Inches		
	Min.	Typ.	Max.	Min.	Typ.	Max.
A			1.10			0.043
A1	0.05	0.10	0.15	0.002	0.004	0.006
A2	0.78	0.86	0.94	0.031	0.034	0.037
b	0.25	0.33	0.40	0.010	0.013	0.016
c	0.15	0.23	0.30	0.006	0.009	0.012
D	2.90	3.00	3.10	0.114	0.118	0.122
E	4.75	4.90	5.05	0.187	0.193	0.199
E1	2.90	3.00	3.10	0.114	0.118	0.122
e		0.50			0.020	
L	0.40	0.55	0.70	0.016	0.022	0.028
L1		0.95			0.037	
k	0°	3°	6°	0°	3°	6°
aaa			0.10			0.004

5.5 TSSOP14 package information

Figure 27. TSSOP14 package mechanical drawing

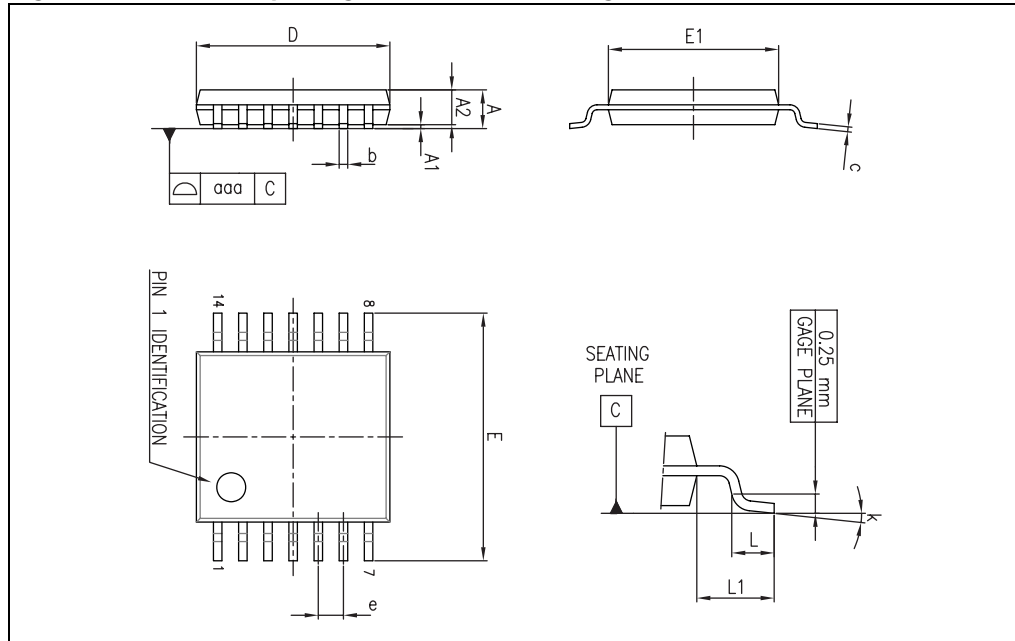

Table 13. TSSOP14 package mechanical data

Ref.	Dimensions					
	Millimeters			Inches		
	Min.	Typ.	Max.	Min.	Typ.	Max.
A			1.20			0.047
A1	0.05		0.15	0.002	0.004	0.006
A2	0.80	1.00	1.05	0.031	0.039	0.041
b	0.19		0.30	0.007		0.012
c	0.09		0.20	0.004		0.0089
D	4.90	5.00	5.10	0.193	0.197	0.201
E	6.20	6.40	6.60	0.244	0.252	0.260
E1	4.30	4.40	4.50	0.169	0.173	0.176
e		0.65			0.0256	
L	0.45	0.60	0.75	0.018	0.024	0.030
L1		1.00			0.039	
k	0°		8°	0°		8°
aaa			0.10			0.004

5.6 TSSOP16 package information

Figure 28. TSSOP16 package mechanical drawing

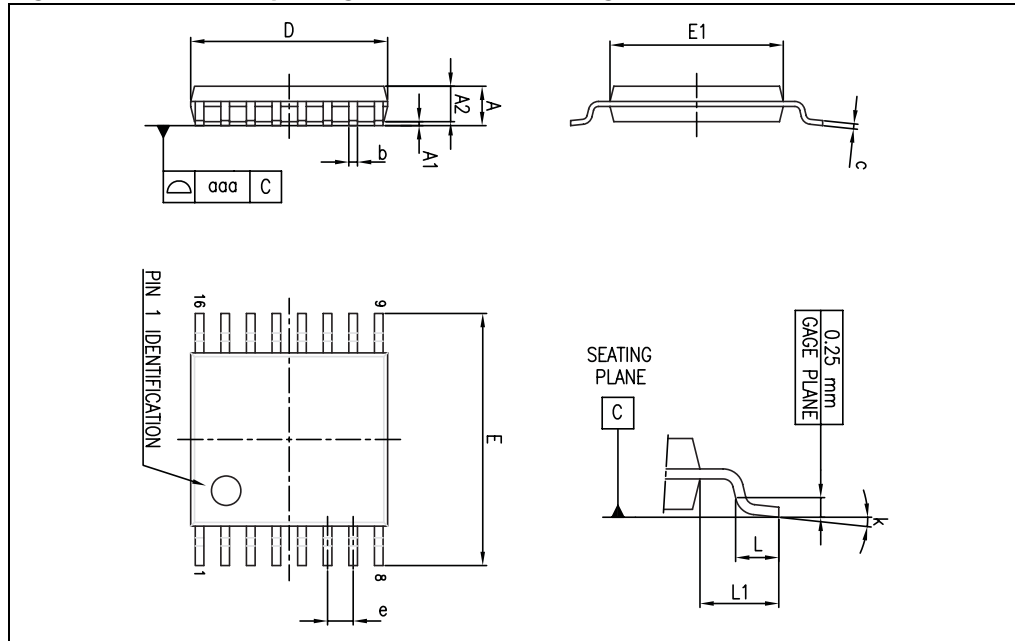

Table 14. TSSOP16 package mechanical data

Ref.	Dimensions					
	Millimeters			Inches		
	Min.	Typ.	Max.	Min.	Typ.	Max.
A			1.20			0.047
A1	0.05		0.15	0.002		0.006
A2	0.80	1.00	1.05	0.031	0.039	0.041
b	0.19		0.30	0.007		0.012
c	0.09		0.20	0.004		0.008
D	4.90	5.00	5.10	0.193	0.197	0.201
E	6.20	6.40	6.60	0.244	0.252	0.260
E1	4.30	4.40	4.50	0.169	0.173	0.177
e		0.65			0.0256	
k	0°		8°	0°		8°
L	0.45	0.60	0.75	0.018	0.024	0.030
L1		1.00			0.039	
aaa			0.10			0.004

6 Ordering information

Table 15. Order codes

Part number	Temperature range	Package	Packing	Marking
TSV622ID/DT	-40° C to +125° C	SO-8	Tube and tape & reel	TSV622
TSV622AID/DT				TSV622A
TSV622IST		MiniSO-8	Tape & reel	K107
TSV622AIST				K143
TSV622ILT		SOT23-8	Tape & reel	K107
TSV622AILT				K136
TSV623IST		MiniSO-10	Tape & reel	K114
TSV623AIST				K144
TSV624IPT		TSSOP-14	Tape & reel	TSV624
TSV624AIPT				TSV624A
TSV625IPT		TSSOP-16	Tape & reel	TSV625
TSV625AIPT				TSV625A

7 Revision history

Table 16. Document revision history

Date	Revision	Changes
25-May-2009	1	Initial release.
15-Jun-2009	2	Corrected pin connection diagram in Figure 1 .
24-Aug-2009	3	Added root part numbers (TSV62xA) and Table 1: Device summary on cover page. Added order code TSV622AILT in Table 15: Order codes .
22-Oct-2009	4	Corrected error in Table 15: Order codes : TSV625 offered in TSSOP16.

Please Read Carefully:

Information in this document is provided solely in connection with ST products. STMicroelectronics NV and its subsidiaries ("ST") reserve the right to make changes, corrections, modifications or improvements, to this document, and the products and services described herein at any time, without notice.

All ST products are sold pursuant to ST's terms and conditions of sale.

Purchasers are solely responsible for the choice, selection and use of the ST products and services described herein, and ST assumes no liability whatsoever relating to the choice, selection or use of the ST products and services described herein.

No license, express or implied, by estoppel or otherwise, to any intellectual property rights is granted under this document. If any part of this document refers to any third party products or services it shall not be deemed a license grant by ST for the use of such third party products or services, or any intellectual property contained therein or considered as a warranty covering the use in any manner whatsoever of such third party products or services or any intellectual property contained therein.

UNLESS OTHERWISE SET FORTH IN ST'S TERMS AND CONDITIONS OF SALE ST DISCLAIMS ANY EXPRESS OR IMPLIED WARRANTY WITH RESPECT TO THE USE AND/OR SALE OF ST PRODUCTS INCLUDING WITHOUT LIMITATION IMPLIED WARRANTIES OF MERCHANTABILITY, FITNESS FOR A PARTICULAR PURPOSE (AND THEIR EQUIVALENTS UNDER THE LAWS OF ANY JURISDICTION), OR INFRINGEMENT OF ANY PATENT, COPYRIGHT OR OTHER INTELLECTUAL PROPERTY RIGHT.

UNLESS EXPRESSLY APPROVED IN WRITING BY AN AUTHORIZED ST REPRESENTATIVE, ST PRODUCTS ARE NOT RECOMMENDED, AUTHORIZED OR WARRANTED FOR USE IN MILITARY, AIR CRAFT, SPACE, LIFE SAVING, OR LIFE SUSTAINING APPLICATIONS, NOR IN PRODUCTS OR SYSTEMS WHERE FAILURE OR MALFUNCTION MAY RESULT IN PERSONAL INJURY, DEATH, OR SEVERE PROPERTY OR ENVIRONMENTAL DAMAGE. ST PRODUCTS WHICH ARE NOT SPECIFIED AS "AUTOMOTIVE GRADE" MAY ONLY BE USED IN AUTOMOTIVE APPLICATIONS AT USER'S OWN RISK.

Resale of ST products with provisions different from the statements and/or technical features set forth in this document shall immediately void any warranty granted by ST for the ST product or service described herein and shall not create or extend in any manner whatsoever, any liability of ST.

ST and the ST logo are trademarks or registered trademarks of ST in various countries.

Information in this document supersedes and replaces all information previously supplied.

The ST logo is a registered trademark of STMicroelectronics. All other names are the property of their respective owners.

© 2009 STMicroelectronics - All rights reserved

STMicroelectronics group of companies

Australia - Belgium - Brazil - Canada - China - Czech Republic - Finland - France - Germany - Hong Kong - India - Israel - Italy - Japan - Malaysia - Malta - Morocco - Philippines - Singapore - Spain - Sweden - Switzerland - United Kingdom - United States of America

www.st.com

