



# TSM104W/A

## QUAD OPERATIONAL AMPLIFIER AND PROGRAMMABLE VOLTAGE REFERENCE

### OPERATIONAL AMPLIFIERS

- LOW SUPPLY CURRENT : 375µA/op. (@  $V_{CC} = 5V$ )
- LOW INPUT BIAS CURRENT : 20nA
- MEDIUM SPEED : 0.9MHz
- LOW INPUT OFFSET VOLTAGE : 0.5mV typ for TSM104WA
- WIDE POWER SUPPLY RANGE :  $\pm 1.5V$  to  $\pm 15V$
- 2kV ESD PROTECTION

### VOLTAGE REFERENCE

- ADJUSTABLE OUTPUT VOLTAGE :  $V_{ref}$  to 36V
- 0.4% AND 1% VOLTAGE PRECISION
- SINK CURRENT CAPABILITY : 1 to 100mA
- TYPICAL OUTPUT IMPEDANCE : 0.2Ω

### DESCRIPTION

The TSM104W is a monolithic IC that includes four op-amps and an adjustable shunt voltage reference. This device is offering space and cost saving in many applications like power supply management or data acquisition systems.

### PIN CONNECTIONS (top view)

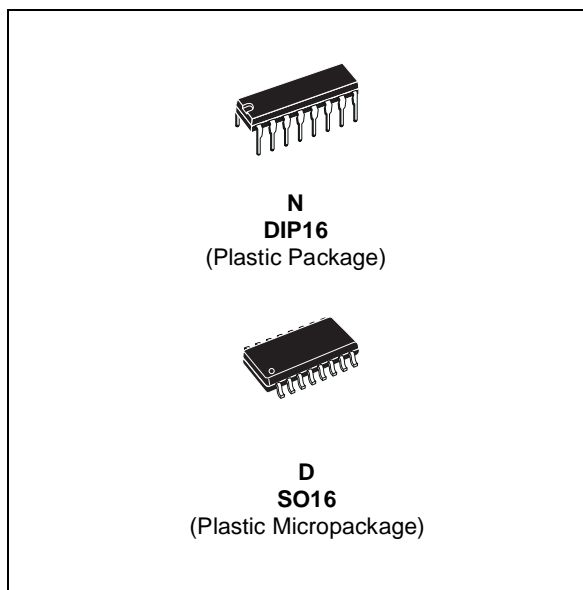
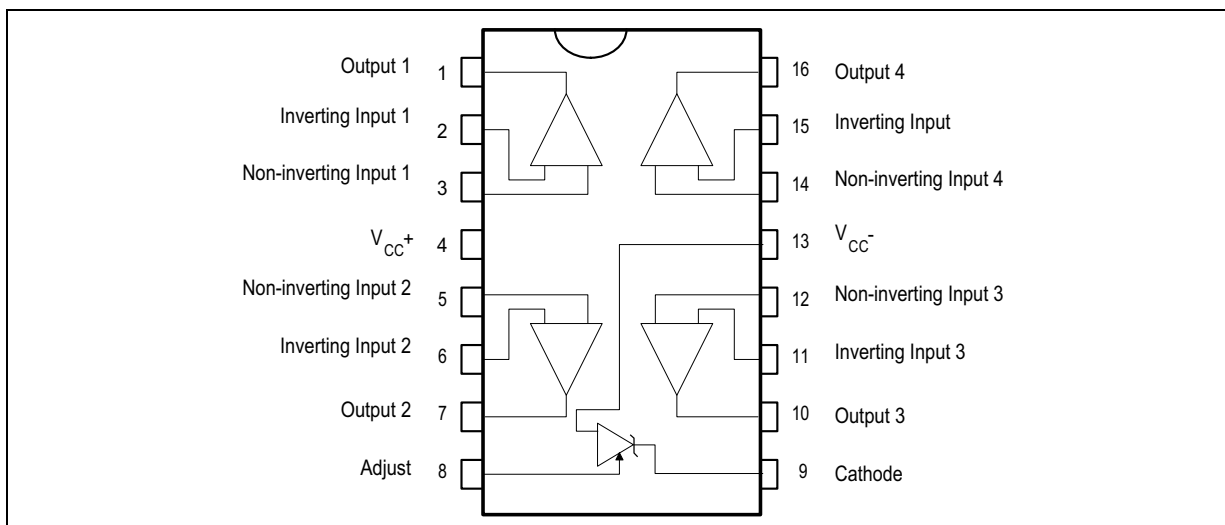

### ORDER CODE

Part Number	Temperature Range	Package	
		N	D
TSM104WI/AI	-40°C, +105°C	•	•

N = Dual in Line Package (DIP)  
D = Small Outline Package (SO) - also available in Tape & Reel (DT)

**ABSOLUTE MAXIMUM RATINGS**

Symbol	Parameter	Value	Unit
$V_{CC}$	Supply Voltage	36	V
$V_{id}$	Differential Input Voltage	36	V
$V_i$	Input Voltage	-0.3 to $V_{CC} + 0.3$	V
	Output Short-circuit Duration	Infinite	
$T_{oper}$	Operating Free-Air Temperature Range	-55 to +125	°C
$T_j$	Maximum Junction Temperature	150	°C
$R_{thja}$	Thermal Resistance Junction to Ambient (SO package)	150	°C/W
ESD	Electrostatic Discharge Protection	2	kV

**ELECTRICAL CHARACTERISTICS**

$V_{CC}^+ = 5V$ ,  $V_{CC}^- = 0V$ ,  $T_{amb} = 25^\circ C$  (unless otherwise specified)

Symbol	Parameter	Min	Typ	Max	Unit
$I_{CC}$	Total Supply Current, excluding current in the Voltage Reference  $V_{CC}^+ = 5V$ , no load $T_{min.} < T_{amb} < T_{max.}$  $V_{CC}^+ = 30V$ , no load $T_{min.} < T_{amb} < T_{max.}$		1.4	2.4	mA
				4	

**ELECTRICAL CHARACTERISTICS**
 $V_{CC}^+ = 5V$ ,  $V_{CC}^- = \text{Ground}$ ,  $V_O = 1.4V$ ,  $T_{\text{amb}} = 25^\circ\text{C}$  (unless otherwise specified)

Symbol	Parameter	Min.	Typ.	Max.	Unit
$V_{io}$	Input Offset Voltage TSM104W, $T_{\text{amb}} = 25^\circ\text{C}$ $T_{\text{min}} \leq T_{\text{amb}} \leq T_{\text{max}}$ TSM104WA, $T_{\text{amb}} = 25^\circ\text{C}$ $T_{\text{min}} \leq T_{\text{amb}} \leq T_{\text{max}}$		1 0.5	5 6 3 4	mV
$\Delta V_{io}$	Input Offset Voltage Drift		7		$\mu\text{V}/^\circ\text{C}$
$I_{io}$	Input Offset Current $T_{\text{min}} \leq T_{\text{amb}} \leq T_{\text{max}}$		2	30 50	nA
$I_{ib}$	Input Bias Current $T_{\text{min}} \leq T_{\text{amb}} \leq T_{\text{max}}$		20	150 200	nA
$A_{vd}$	Large Signal Voltage Gain $V_{CC} = 15V$ , $R_L = 2k$ $V_O = 1.4V$ to $11.4V$ $T_{\text{min}} \leq T_{\text{amb}} \leq T_{\text{max}}$	50 25	100		V/mV
SVR	Supply Voltage Rejection Ratio $V_{CC} = 5V$ to $30V$	65	100		dB
$V_{icm}$	Input Voltage Mode Voltage Range $V_{CC} = +30V$ see note <sup>1)</sup> $T_{\text{min}} \leq T_{\text{amb}} \leq T_{\text{max}}$	0 0		$V_{CC}^+ - 1.5$ $V_{CC}^+ - 2$	V
CMR	Common Mode Rejection Ratio $T_{\text{min}} \leq T_{\text{amb}} \leq T_{\text{max}}$	70 60	85		dB
$I_{\text{source}}$	Output Current Source $V_O = 2V$ , $V_{CC} = +15V$ , $V_{id} = +1V$	20	40		mA
$I_o$	Output Short Circuit to Ground $V_{CC} = +15V$		40	60	mA
$I_{\text{sink}}$	Output Current Sink $V_{id} = -1V$ $V_{CC} = +15V$ , $V_O = +2V$	10	20		mA
$V_{OH}$	High Level Output Voltage $R_L = 10k$ , $V_{CC}^+ = 30V$ $T_{\text{amb}} = 25^\circ\text{C}$ $T_{\text{min}} \leq T_{\text{amb}} \leq T_{\text{max}}$	27 27	28		V
$V_{OL}$	Low Level Output Voltage $R_L = 10k$ $T_{\text{min}} \leq T_{\text{amb}} \leq T_{\text{max}}$		5	20 20	mV
SR	Slew Rate at Unity Gain $V_i = 0.5$ to $3V$ , $V_{CC} = 15V$ $R_L = 2k\Omega$ , $C_L = 100\text{pF}$ , unity gain	0.1	0.3		V/ $\mu\text{s}$
GBP	Gain Bandwidth Product $V_{CC} = 30V$ , $R_L = 2k$ , $C_L = 100\text{pF}$ $f = 100\text{kHz}$ , $V_{in} = 10\text{mV}$	0.5	0.9		MHz
THD	Total Harmonic Distortion $f = 1\text{kHz}$ $A_V = 20\text{dB}$ , $R_L = 2$ , $V_{CC} = 30V$ $C_L = 100\text{pF}$ , $V_O = 2V_{pp}$		0.02		%
$e_n$	Equivalent Input Noise Voltage $f = 1\text{kHz}$ , $V_{CC} = 30V$ , $R_S = 100\Omega$		50		$\frac{\text{nV}}{\sqrt{\text{Hz}}}$
$C_s$	Channel Separation $1\text{kHz} < f < 20\text{kHz}$		120		dB

1. The input common-mode voltage of either input signal voltage should not be allowed to go negative by more than 0.3V. The upper end of the common-mode voltage range is  $V_{CC}^+ - 1.5V$ , but either of both inputs can go to  $V_{CC}^+ + 0.3V$  without damage.

**VOLTAGE REFERENCE**

Symbol	Conditions	Value	Unit
$I_K$	Cathode Current	1 to 100	mA

Symbol	Parameter	Min	Typ	Max	Unit
$V_{ref}$	Reference Input Voltage TSM104W, $T_{amb} = 25^{\circ}C$ $T_{min} \leq T_{amb} \leq T_{max}$ TSM104WA, $T_{amb} = 25^{\circ}C$ $T_{min} \leq T_{amb} \leq T_{max}$	2.475 2.45 2.49 2.48	2.5 2.5	2.525 2.55 2.51 2.52	V
$\Delta V_{ref}$	Reference Input Voltage Deviation Over Temperature Range $V_{KA} = V_{ref}$ , $I_K = 10mA$ $T_{min} \leq T_{amb} \leq T_{max}$		7	30	mV
$\frac{\Delta V_{ref}}{\Delta V_{KA}}$	Ratio of Change in Reference Input Voltage to Change in Cathode to Anode Voltage $I_K = 10mA$ , $\Delta V_{KA} = 36V$ to $3V$	-2	-1.1		mV/V
$I_{ref}$	Reference Input Current $I_K = 10mA$ $T_{min} \leq T_{amb} \leq T_{max}$		1.5	2.5 3	$\mu A$
$\Delta I_{ref}$	Reference Input Current Deviation over $T^{\circ}$ Range		0.8	1.2	$\mu A$
$I_{min}$	Minimum Cathode Current for Regulation $V_{KA} = V_{ref}$		0.5	1	mA
$I_{off}$	Off-State Cathode Current		180	500	nA
$ Z_{KA} $	Dynamic Impedance - note 1 $V_{KA} = V_{ref}$ , $\Delta I_K = 1$ to $100mA$ , $f < 1kHz$		0.2	0.5	$\Omega$

1) The dynamic impedance is defined as  $|Z_{KA}| = \frac{\Delta V_{KA}}{\Delta I_K}$

OPERATIONAL AMPLIFIERS

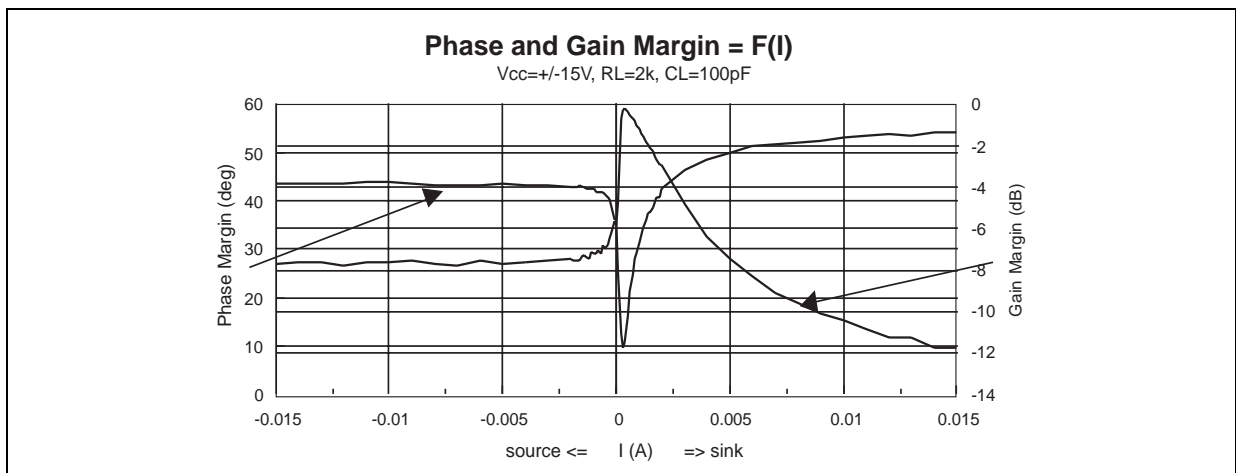
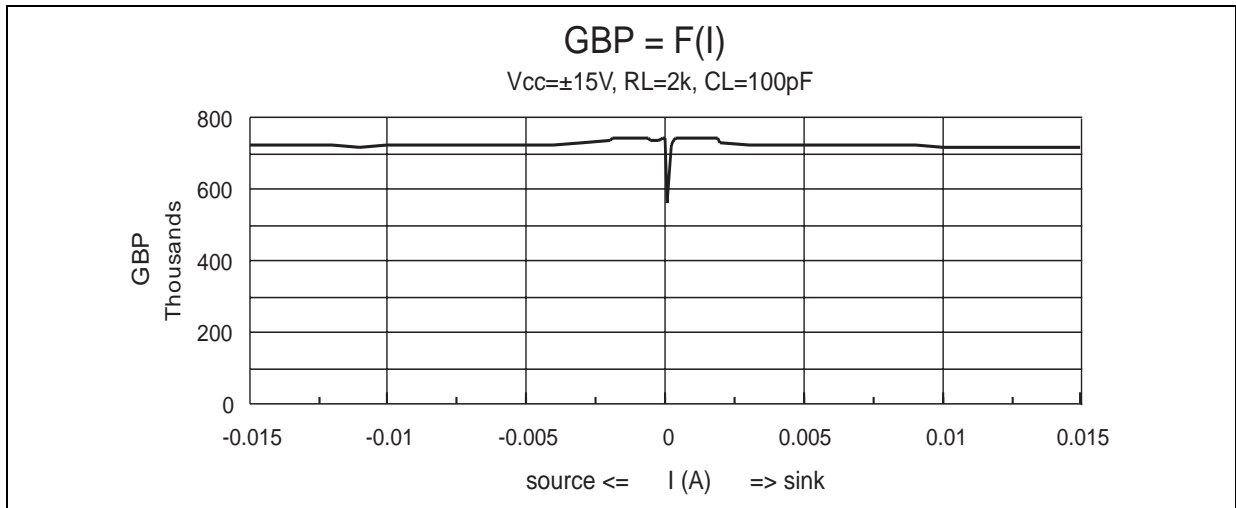
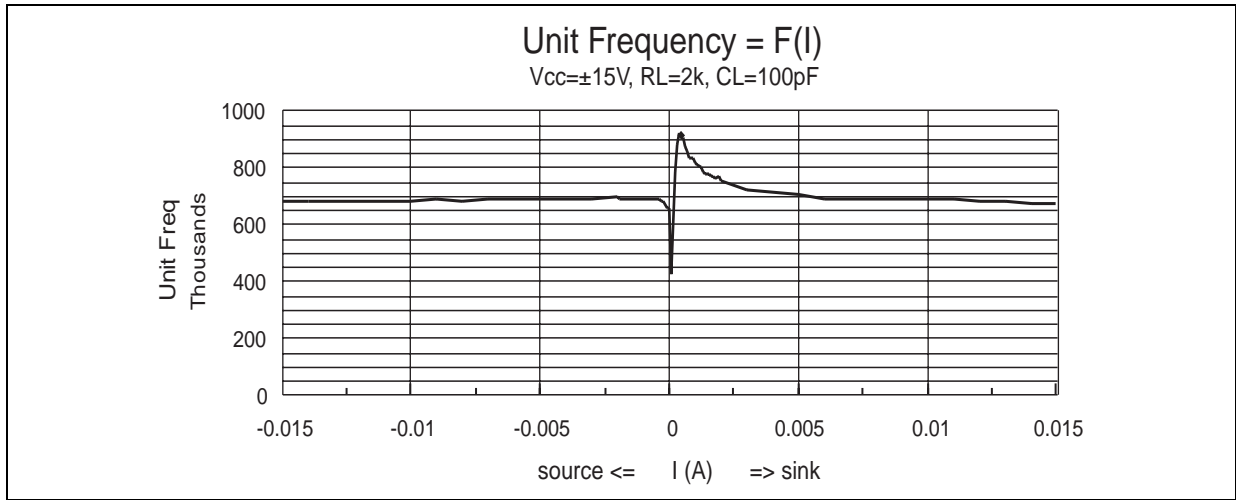

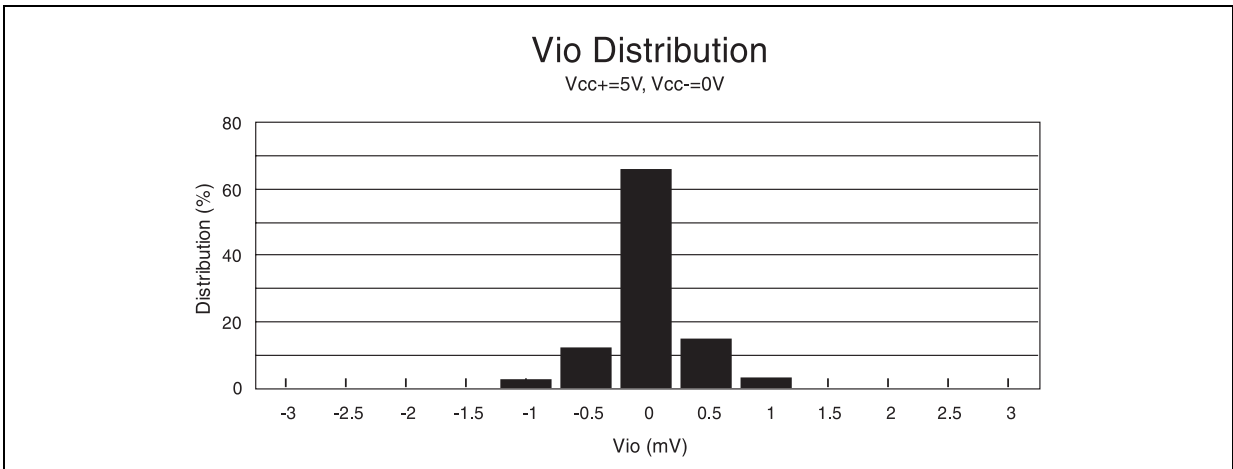
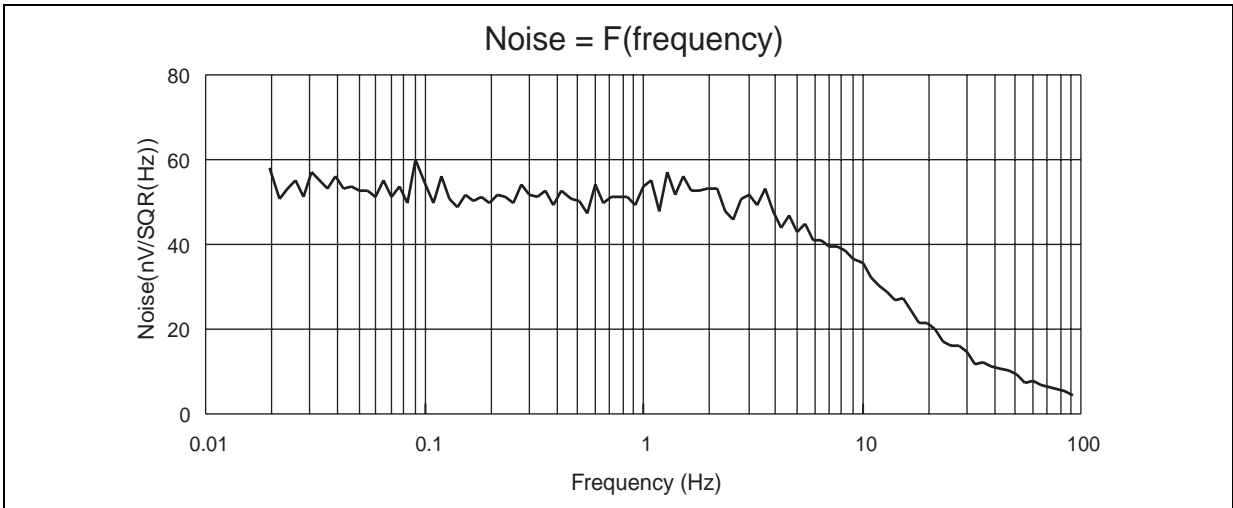
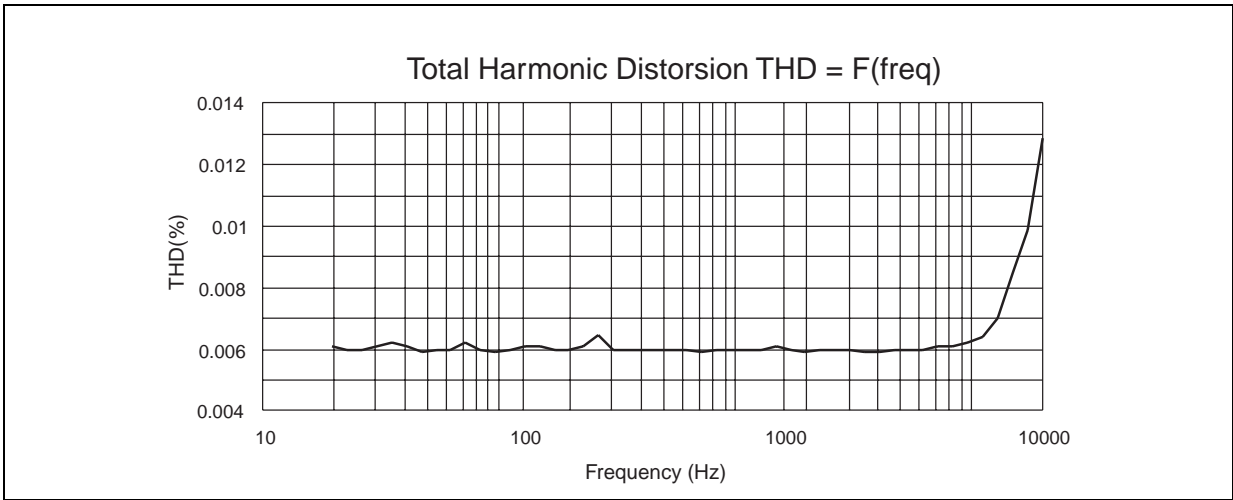

VOLTAGE REFERENCE

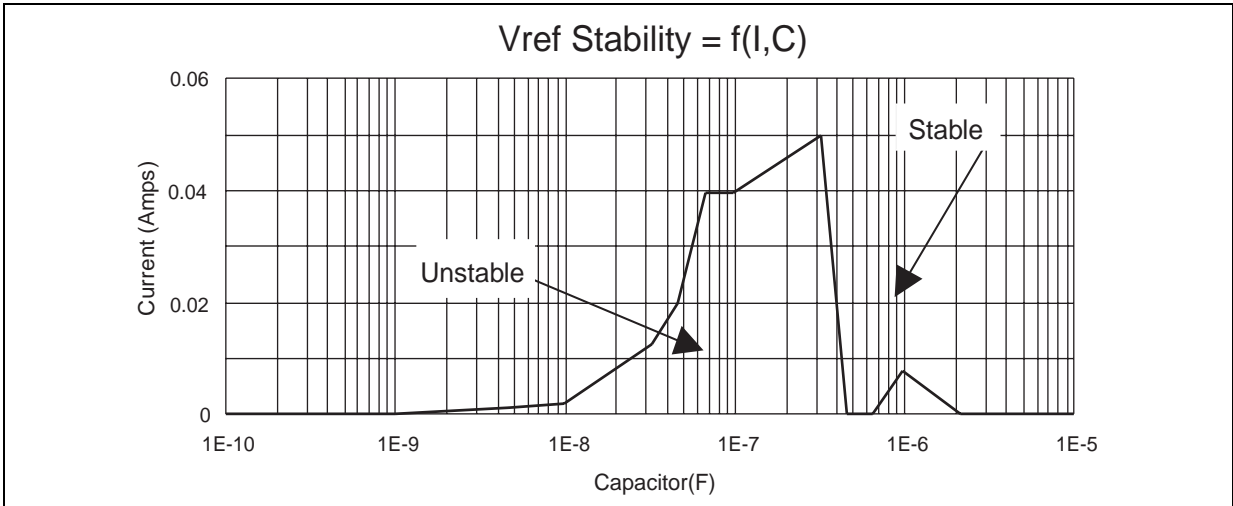
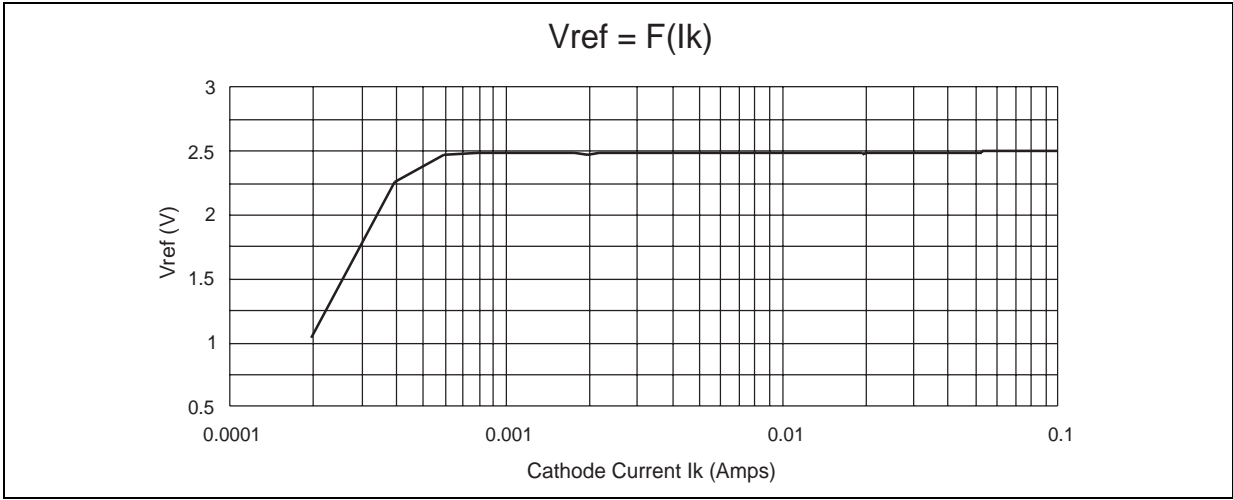

**PACKAGE MECHANICAL DATA**  
16 PINS - PLASTIC PACKAGE

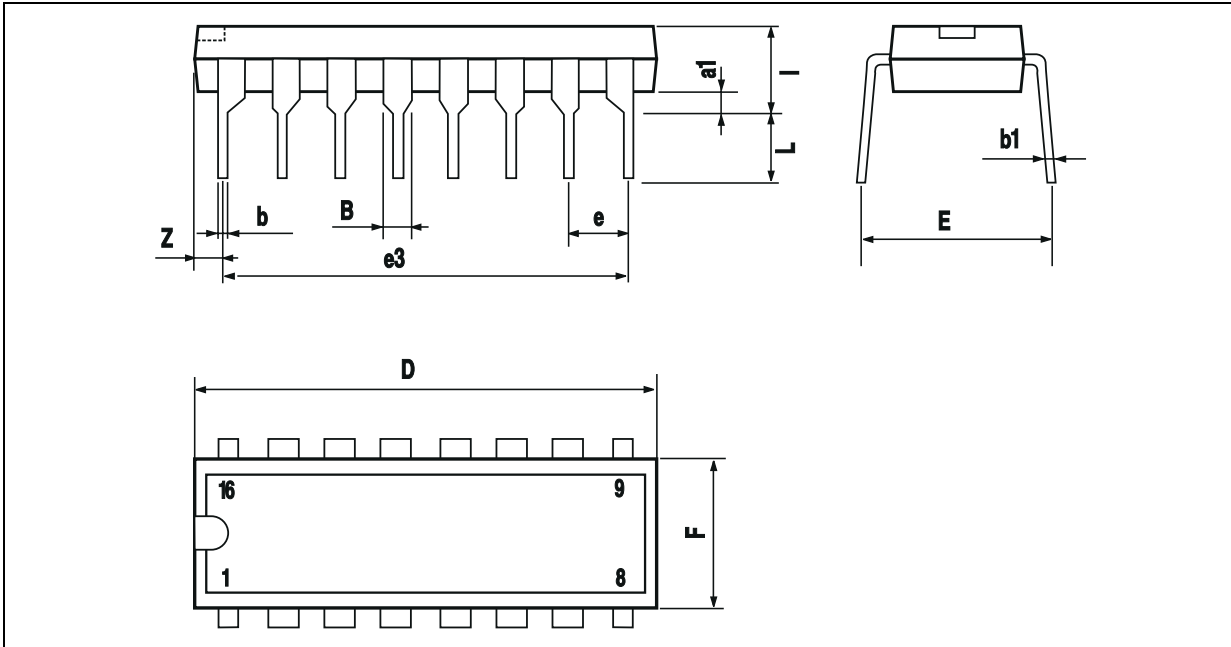

Dim.	Millimeters			Inches		
	Min.	Typ.	Max.	Min.	Typ.	Max.
a1	0.51			0.020		
B	0.77		1.65	0.030		0.065
b		0.5			0.020	
b1		0.25			0.010	
D			20			0.787
E		8.5			0.335	
e		2.54			0.100	
e3		17.78			0.700	
F			7.1			0.280
i			5.1			0.201
L		3.3			0.130	
Z			1.27			0.050



**PACKAGE MECHANICAL DATA**  
16 PINS - PLASTIC MICROPACKAGE (SO)

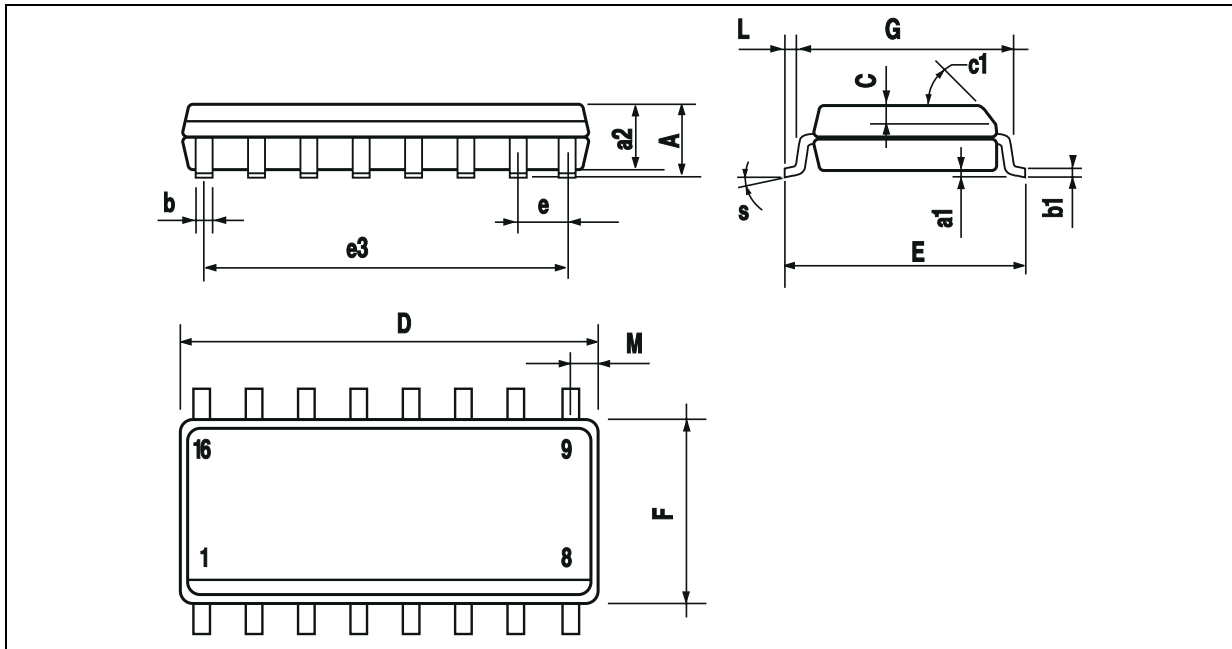

Dim.	Millimeters			Inches		
	Min.	Typ.	Max.	Min.	Typ.	Max.
A			1.75			0.069
a1	0.1		0.2	0.004		0.008
a2			1.6			0.063
b	0.35		0.46	0.014		0.018
b1	0.19		0.25	0.007		0.010
C		0.5			0.020	
c1	45° (typ.)					
D	9.8		10	0.386		0.394
E	5.8		6.2	0.228		0.244
e		1.27			0.050	
e3		8.89			0.350	
F	3.8		4.0	0.150		0.157
G	4.6		5.3	0.181		0.209
L	0.5		1.27	0.020		0.050
M			0.62			0.024
S	8° (max.)					

Information furnished is believed to be accurate and reliable. However, STMicroelectronics assumes no responsibility for the consequences of use of such information nor for any infringement of patents or other rights of third parties which may result from its use. No license is granted by implication or otherwise under any patent or patent rights of STMicroelectronics. Specifications mentioned in this publication are subject to change without notice. This publication supersedes and replaces all information previously supplied. STMicroelectronics products are not authorized for use as critical components in life support devices or systems without express written approval of STMicroelectronics.

The ST logo is a registered trademark of STMicroelectronics

© 2003 STMicroelectronics - All Rights Reserved  
STMicroelectronics GROUP OF COMPANIES

Australia - Brazil - China - Finland - France - Germany - Hong Kong - India - Italy - Japan - Malaysia - Malta - Morocco  
Singapore - Spain - Sweden - Switzerland - United Kingdom

<http://www.st.com>