

## Wide Bandwidth Dual Bipolar Operational Amplifier

- Internally compensated
- Short-circuit protection
- Gain and phase match between amplifier
- Low power consumption
- Pin-to-pin compatible with MC1458/LM358
- Gain bandwidth product (at 100kHz): 5.5MHz

### Description

The MC4558 is a high performance monolithic dual operational amplifier.

The circuit combines all the outstanding features of the MC1458 and, in addition possesses three times the unity gain bandwidth of the industry standard.

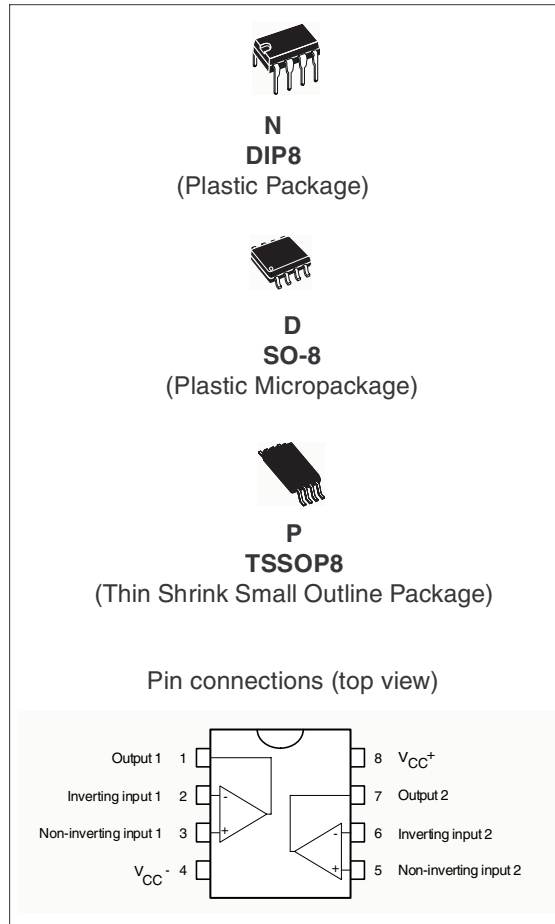

### Order Codes

Part Number	Temperature Range	Package	Packing	Marking
MC4558CN	0°C to +70°C	DIP8	Tube	MC4558CN
MC4558CD/CDT		SO-8	Tube or Tape & Reel	4558C
MC4558CPT		TSSOP8	Tape & Reel	
MC4558IN	-40°C to +105°C	DIP8	Tube	MC4558IN
MC4558ID/IDT		SO-8	Tube or Tape & Reel	4558I
MC4558IPT		TSSOP8 (Thin Shrink Outline Package)	Tape & Reel	

# 1 Absolute Maximum Ratings

**Table 1. Key parameters and their absolute maximum ratings**

Symbol	Parameter	MC4558I	MC4558C	Unit
$V_{CC}$	Supply Voltage	±22		V
$V_i^{(1)}$	Input Voltage	±15		V
$V_{id}^{(2)}$	Differential Input Voltage	±30		V
$P_{tot}$	Power Dissipation	680		mW
	Output Short Circuit Duration	Infinite		
$T_{oper}$	Operating Free-Air Temperature Range	-40 to +105	0 to +70	°C
$R_{thja}$	Thermal Resistance Junction to Ambient			°C/W
	SO-8	125		
	TSSOP8	120		
	DIP8	85		
ESD	HBM: Human Body Model <sup>(3)</sup>	500		V
	MM: Machine Model <sup>(4)</sup>	500		
	CDM: Charged Device Model	1500		

1. Input voltage are with respect to the midpoint between  $V_{CC+}$  and  $V_{CC-}$ . Its value must never exceed 15V or the magnitude of  $V_{CC}$ , whichever is less.
2. Differential voltages are the non-inverting input terminal with respect to the inverting input terminal.
3. Human body model, 100pF discharged through a 1.5kΩ resistor into pin of device.
4. Machine model ESD, a 200pF cap is charged to the specified voltage, then discharged directly into the IC with no external series resistor (internal resistor < 5Ω), into pin to pin of device.

**Table 2. Operating conditions**

Symbol	Parameter	Min.	Max.	Unit
$V_{CC}$	Supply voltage	±2	±20	V

## 2 Typical Application Schematic

Figure 1. Schematic diagram (1/2MC4558)

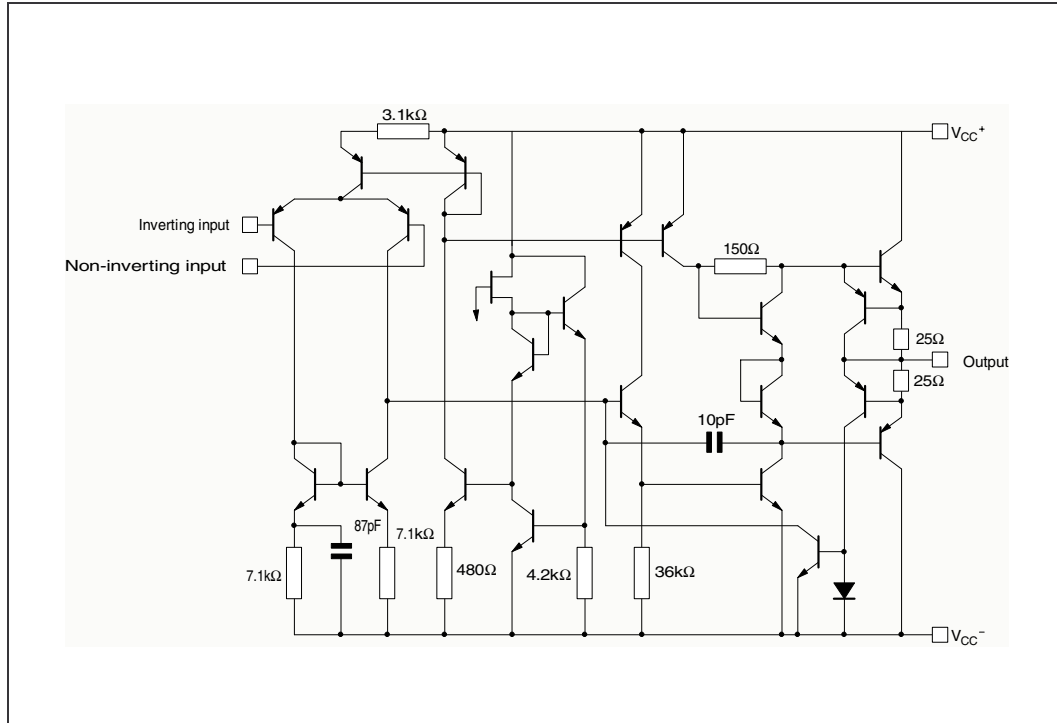

### 3 Electrical Characteristics

**Table 3. Electrical characteristics for  $V_{CC} = \pm 15V$ ,  $T_{amb} = 25^\circ C$  (unless otherwise specified)**

Symbol	Parameter	Min.	Typ.	Max.	Unit
$V_{io}$	Input Offset Voltage ( $R_s \leq 10k\Omega$ ) $T_{amb} = +25^\circ C$ $T_{min} \leq T_{amb} \leq T_{max}$ .		1	5 6	mV
$I_{io}$	Input Offset Current $T_{amb} = +25^\circ C$ $T_{min} \leq T_{amb} \leq T_{max}$ .		20	100 200	nA
$I_{ib}$	Input Bias Current $T_{amb} = +25^\circ C$ $T_{min} \leq T_{amb} \leq T_{max}$ .		50	400 500	nA
$A_{vd}$	Large Signal Voltage Gain ( $R_L = 2k\Omega$ , $V_o = \pm 10V$ ) $T_{amb} = +25^\circ C$ $T_{min} \leq T_{amb} \leq T_{max}$ .	50 25	200		V/mV
SVR	Supply Voltage Rejection Ratio ( $R_s \leq 10k\Omega$ ) $T_{amb} = +25^\circ C$ $T_{min} \leq T_{amb} \leq T_{max}$ .	77 77	90		dB
$I_{CC}$	Supply Current, all amplifiers, no load $T_{amb} = +25^\circ C$ $T_{min} \leq T_{amb} \leq T_{max}$ .		2.3	4.5 6	mA
$V_{icm}$	Input Common Mode Voltage Range $T_{amb} = +25^\circ C$ $T_{min} \leq T_{amb} \leq T_{max}$ .	$\pm 12$ $\pm 12$			V
CMR	Common-mode Rejection Ratio ( $R_s \leq 10k\Omega$ ) $T_{amb} = +25^\circ C$ $T_{min} \leq T_{amb} \leq T_{max}$ .	70 70	90		dB
$I_{os}$	Output Short Circuit Current	10	20	40	mA
$V_o$	Output Voltage Swing $T_{amb} = +25^\circ C$ $R_L = 10k\Omega$ $R_L = 2k\Omega$ $T_{min} \leq T_{amb} \leq T_{max}$ . $R_L = 10k\Omega$ $R_L = 2k\Omega$	$\pm 12$ $\pm 10$ $\pm 12$ $\pm 10$	$\pm 14$ $\pm 13$		V
SR	Slew Rate $V_i = \pm 10$ , $R_L = 2k\Omega$ , $C_L = 100pF$ , $T_{amb} = 25^\circ C$ , unity gain	1.5	2.2		V/ $\mu s$
$t_r$	Rise Time $V_i = \pm 20mV$ , $R_L = 2k\Omega$ , $C_L = 100pF$ , $T_{amb} = 25^\circ C$ , unity gain		0.3		$\mu s$
$K_{OV}$	Overshoot $V_i = \pm 20mV$ , $R_L = 2k\Omega$ , $C_L = 100pF$ , $T_{amb} = 25^\circ C$ , unity gain		15		%
$R_i$	Input Resistance	0.3	2		M $\Omega$

Table 3. Electrical characteristics for  $V_{CC} = \pm 15V$ ,  $T_{amb} = 25^{\circ}C$  (unless otherwise specified)

Symbol	Parameter	Min.	Typ.	Max.	Unit
$C_i$	Input Capacitance		1.4		pF
$R_o$	Output Resistance		75		$\Omega$
B	Unity Gain Bandwidth		2.8		MHz
GBP	Gain Bandwidth Product $V_i = 10mV$ , $R_L = 2k\Omega$ , $C_L = 100pF$ , $f = 100kHz$ , $T_{amb} = 25^{\circ}C$		5.5		MHz
THD	Total Harmonic Distortion $f = 1kHz$ , $A_v = 20dB$ , $R_L = 2k\Omega$ , $V_o = 2V_{pp}$ , $C_L = 100pF$ , $T_{amb} = 25^{\circ}C$		0.008		%
$e_n$	Equivalent Input Noise Voltage ( $R_S = 100\Omega$ , $f = 1kHz$ )		12		$\frac{nV}{\sqrt{Hz}}$
$V_{O1}/V_{O2}$	Channel Separation		120		dB

Figure 2. Transient response test circuit

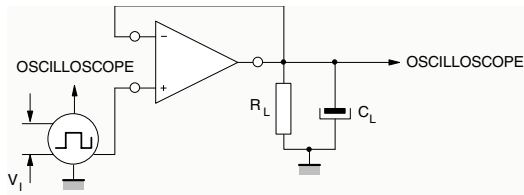

Figure 3. Positive output voltage swing vs. load resistance

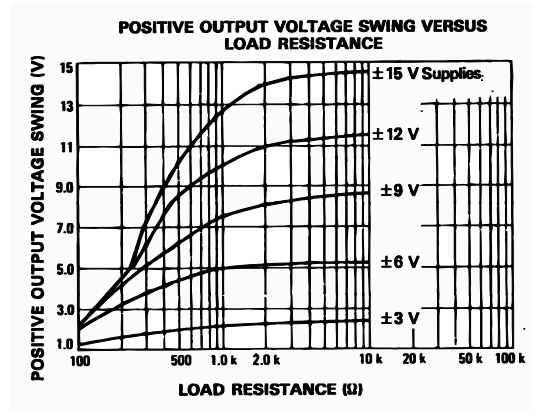

Figure 4. Open loop frequency response

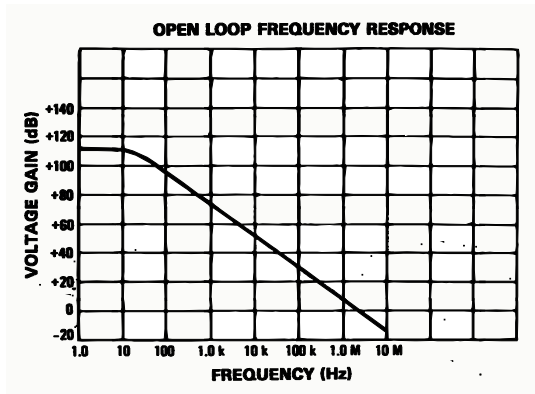

Figure 5. Negative output voltage swing vs. load resistance

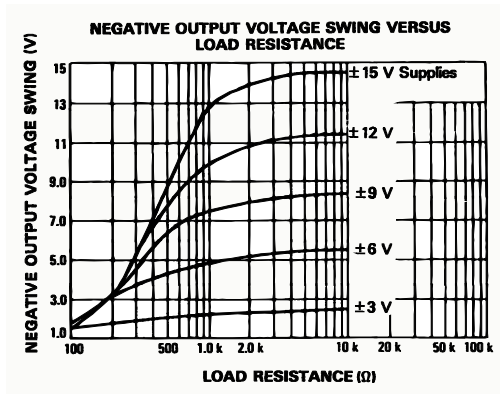

Figure 6. Phase margin vs. frequency

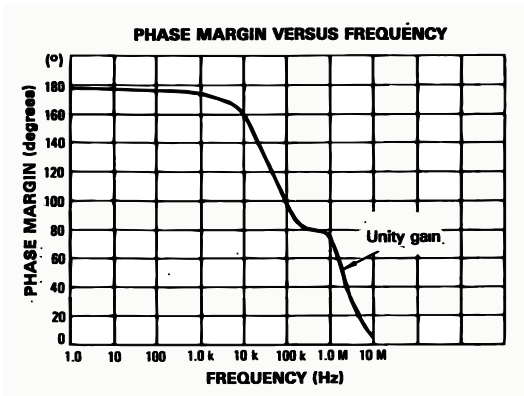
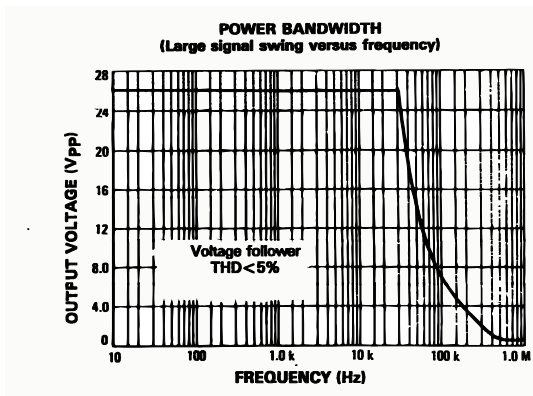

Figure 7. Power bandwidth



## 4 Package Mechanical Data

In order to meet environmental requirements, ST offers these devices in ECOPACK<sup>®</sup> packages. These packages have a Lead-free second level interconnect. The category of second level interconnect is marked on the package and on the inner box label, in compliance with JEDEC Standard JESD97. The maximum ratings related to soldering conditions are also marked on the inner box label. ECOPACK is an ST trademark. ECOPACK specifications are available at: [www.st.com](http://www.st.com).

### 4.1 DIP8 package

**Plastic DIP-8 MECHANICAL DATA**

DIM.	mm.			inch		
	MIN.	TYP.	MAX.	MIN.	TYP.	MAX.
A		3.3			0.130	
a1	0.7			0.028		
B	1.39		1.65	0.055		0.065
B1	0.91		1.04	0.036		0.041
b		0.5			0.020	
b1	0.38		0.5	0.015		0.020
D			9.8			0.386
E		8.8			0.346	
e		2.54			0.100	
e3		7.62			0.300	
e4		7.62			0.300	
F			7.1			0.280
l			4.8			0.189
L		3.3			0.130	
Z	0.44		1.6	0.017		0.063

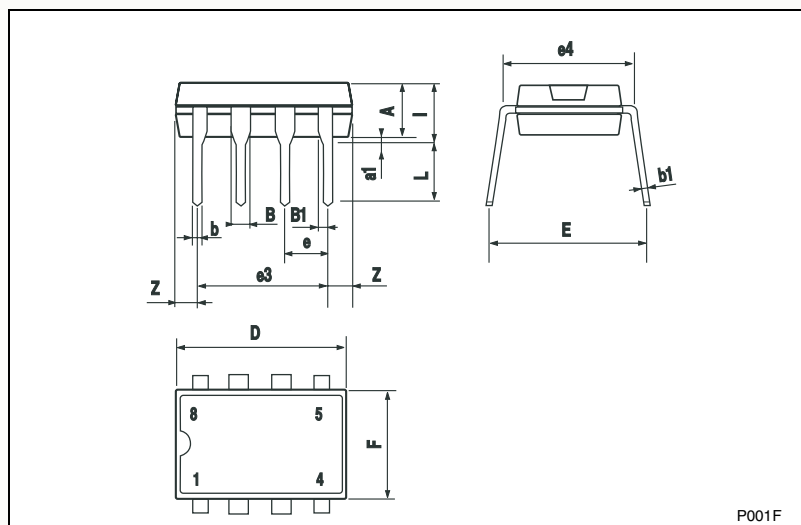

P001F

### 4.2 SO-8 package

**SO-8 MECHANICAL DATA**

DIM.	mm.			inch		
	MIN.	TYP.	MAX.	MIN.	TYP.	MAX.
A	1.35		1.75	0.053		0.069
A1	0.10		0.25	0.04		0.010
A2	1.10		1.65	0.043		0.065
B	0.33		0.51	0.013		0.020
C	0.19		0.25	0.007		0.010
D	4.80		5.00	0.189		0.197
E	3.80		4.00	0.150		0.157
e		1.27			0.050	
H	5.80		6.20	0.228		0.244
h	0.25		0.50	0.010		0.020
L	0.40		1.27	0.016		0.050
k	$8^\circ$ (max.)					
ddd			0.1			0.04

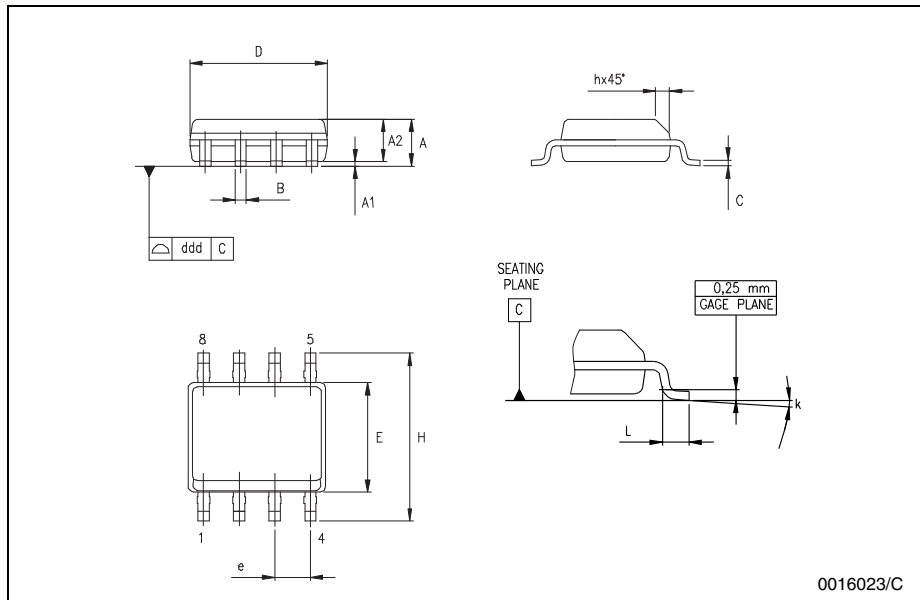

0016023/C



### 4.3 TSSOP8 package

**TSSOP8 MECHANICAL DATA**

DIM.	mm.			inch		
	MIN.	TYP.	MAX.	MIN.	TYP.	MAX.
A			1.2			0.047
A1	0.05		0.15	0.002		0.006
A2	0.80	1.00	1.05	0.031	0.039	0.041
b	0.19		0.30	0.007		0.012
c	0.09		0.20	0.004		0.008
D	2.90	3.00	3.10	0.114	0.118	0.122
E	6.20	6.40	6.60	0.244	0.252	0.260
E1	4.30	4.40	4.50	0.169	0.173	0.177
e		0.65			0.0256	
K	0°		8°	0°		8°
L	0.45	0.60	0.75	0.018	0.024	0.030
L1		1			0.039	

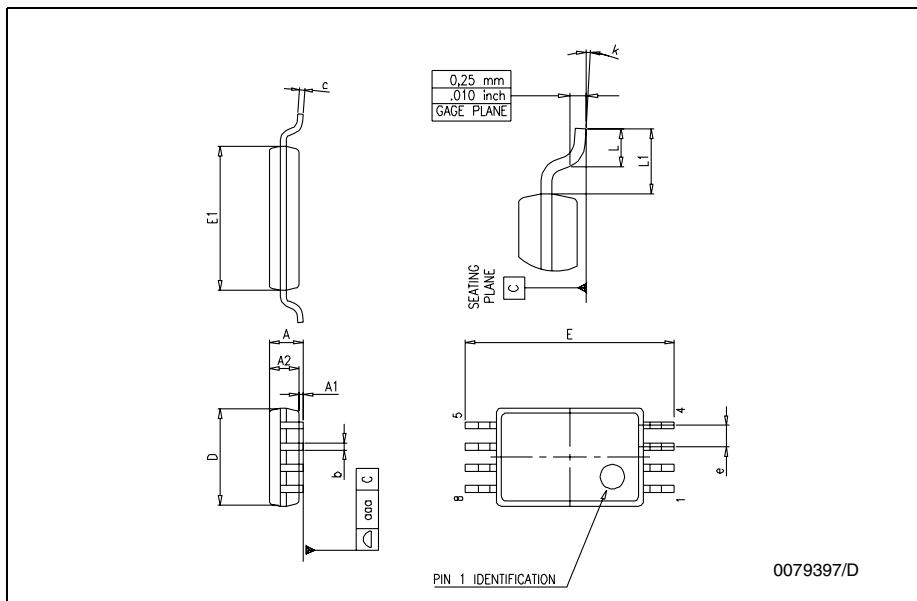

## 5 Revision History

Date	Revision	Changes
Oct. 2001	1	Initial release.
Oct. 2005	2	The following changes were made in this revision: <ul style="list-style-type: none"><li>– <i>Table 2.: Operating conditions on page 2</i> updated with Vcc min. and max.</li><li>– Addition of supplementary data in <i>Table 1.: Key parameters and their absolute maximum ratings on page 2</i></li><li>– Minor grammatical and formatting changes throughout.</li></ul>

Information furnished is believed to be accurate and reliable. However, STMicroelectronics assumes no responsibility for the consequences of use of such information nor for any infringement of patents or other rights of third parties which may result from its use. No license is granted by implication or otherwise under any patent or patent rights of STMicroelectronics. Specifications mentioned in this publication are subject to change without notice. This publication supersedes and replaces all information previously supplied. STMicroelectronics products are not authorized for use as critical components in life support devices or systems without express written approval of STMicroelectronics.

The ST logo is a registered trademark of STMicroelectronics.  
All other names are the property of their respective owners

© 2005 STMicroelectronics - All rights reserved

STMicroelectronics group of companies

Australia - Belgium - Brazil - Canada - China - Czech Republic - Finland - France - Germany - Hong Kong - India - Israel - Italy - Japan - Malaysia - Malta - Morocco - Singapore - Spain - Sweden - Switzerland - United Kingdom - United States of America

[www.st.com](http://www.st.com)