

New Era of Scalable and Highly Integrated Microcontrollers for Automotive Applications



www.infineon.com/XC2000



Never stop thinking



Contents



Contents

XC2000 Family Overview 4

XC2200 for Body & Convenience 6

XC2300 for Safety 10

XC2700 for Powertrain 14

Enhanced Communication 18
MultiCAN, USIC, FlexRay™*

Peripheral Highlights 20

AUTOSAR 21

System Development Tools 22

XC2000

XC2000 – New Era of Scalable and Highly Integrated Microcontrollers for Automotive Applications

INFINEON'S NEW AND POWERFUL XC2000 series is a new standard of 16/32-bit microcontrollers especially designed to address the exacting requirements of automotive applications. Its three dedicated sub-families address three different automotive application segments.

THE XC2200 FAMILY of microcontrollers fulfills all key requirements for present and future body system control such as body control module (BCM), gateway, heating, ventilation, air conditioning (HVAC) and door modules. The XC2300 family will cover safety applications like airbag, electric power steering (EPS) and ABS, where as the XC2700 family addresses powertrain systems.

IN THE AUTOMOTIVE SEGMENT the huge increase in vehicle networking, increased energy efficiency and the adoption of IEC61508 (SIL3) for safety-critical systems such as ABS and power steering, demands major enhancements to the CPU features and peripheral set.

THE BROAD XC2000 product portfolio comprises a multiplicity of different products, offering design engineers the scalability to select an MCU with the optimal combination of memory, peripheral set, frequency, temperature and packaging – just the right MCU to match the application's feature and performance requirements. The compatibility within the families, even in different packages, allows a product change during and after the design cycle, without any changes to the printed circuit board design.

ONCE THE SOFTWARE for Infineon's XC2000 microcontrollers is compiled, it can easily be used for various applications within a car manufacturer's different model platforms. All members of the same family are binary compatible and share the same development tools. Furthermore, an AUTOSAR library that allows easy integration of existing code into XC2000 programs is available.



Body & Convenience



XC2200

Main Features

- Up to 1.6MB eFlash incl. EEPROM
- Up to 6 CAN nodes
- Up to 10 serial interfaces
- Multiple motor control features
- Up to 40-channel 10-bit ADC
- FlexRay™
- Dedicated power-down features

Safety



XC2300

Main Features

- Up to 1.6MB eFlash incl. EEPROM
- Up to 3 CAN nodes
- Up to 8 serial interfaces
- Motor control features
- Up to 24-channel ADC
- FlexRay™
- Dedicated safety features

Powertrain



XC2700

Main Features

- Up to 1.6MB eFlash incl. EEPROM
- Up to 3 CAN nodes
- Up to 4 serial interfaces
- Up to 30-channel 10-bit ADC
- Dedicated powerful motor control features



XC2200

THE XC2200 FAMILY IS A SUB-FAMILY of the new scalable 16/32-bit XC2000 microcontroller series from Infineon, and addresses the increasing complexity of highly integrated body and gateway applications. Available today are XC2200 derivatives from 448 to 768KB of Flash, optional EEPROM emulation, up to 82KB SRAM with max 80MHz CPU clock. Expanding the portfolio up to 1.6MB of Flash memory while addressing even higher performance requirements, Infineon will further enlarge the family with pin-compatible MCUs. This makes the choice in favor of the XC2200 family a safe long-term decision, with Infineon's 130 nm technology offering an additional performance boost at competitive cost.

THE XC2200 FAMILY IS OPTIMIZED for mid-range to high-end body applications. In order to comply with the AUTOSAR programming model that provides for hardware-independent software development, the controllers are equipped with a memory protection unit (MPU). Today's available XC2200 devices address low- to mid-range gateway applications integrated into body controllers. Soon to come variants will enlarge the portfolio, offering a perfect fit for high-end central body and gateway applications. In addition, Infineon has a stand-alone FlexRay™ communication controller available that can be easily added to the system.

Body & Convenience

XC2200

Product Portfolio

Type	eFlash [KB]	RAM [KB]	Serial Interfaces	CAN Nodes	FlexRay™	PWM Channels	ADC Channels	Package	Availability
XC2236N	128–320	10–34	2	2	no	24	10	PG-LQFP-64	2009
XC2264/N	128–768	10–82	4	2	no	24	8	PG-LQFP-100	Available/2009
XC2265N	128–320	10–34	6	3	no	24	16	PG-LQFP-100	2009
XC2267/M	384–832	26–82	6/8	5/6	no	32	16	PG-LQFP-100	Available/2008
XC2285/M	384–832	26–82	4	2	no	24	16	PG-LQFP-144	Available/2008
XC2286/M	384–832	26–82	6/8	3	no	32	24	PG-LQFP-144	Available/2008
XC2287/M	384–832	26–82	6/8	5/6	no	32	24	PG-LQFP-144	Available/2008
XC2297H	832–1600	50–138	10	3	no	48	40	PG-LQFP-176	2009
XC2298H	832–1600	50–138	10	6	no	48	30	PG-LQFP-176	2009
XC2299H	832–1600	50–138	10	6	yes	48	30	PG-LQFP-176	2009

XC2200 Block Diagram (Example)

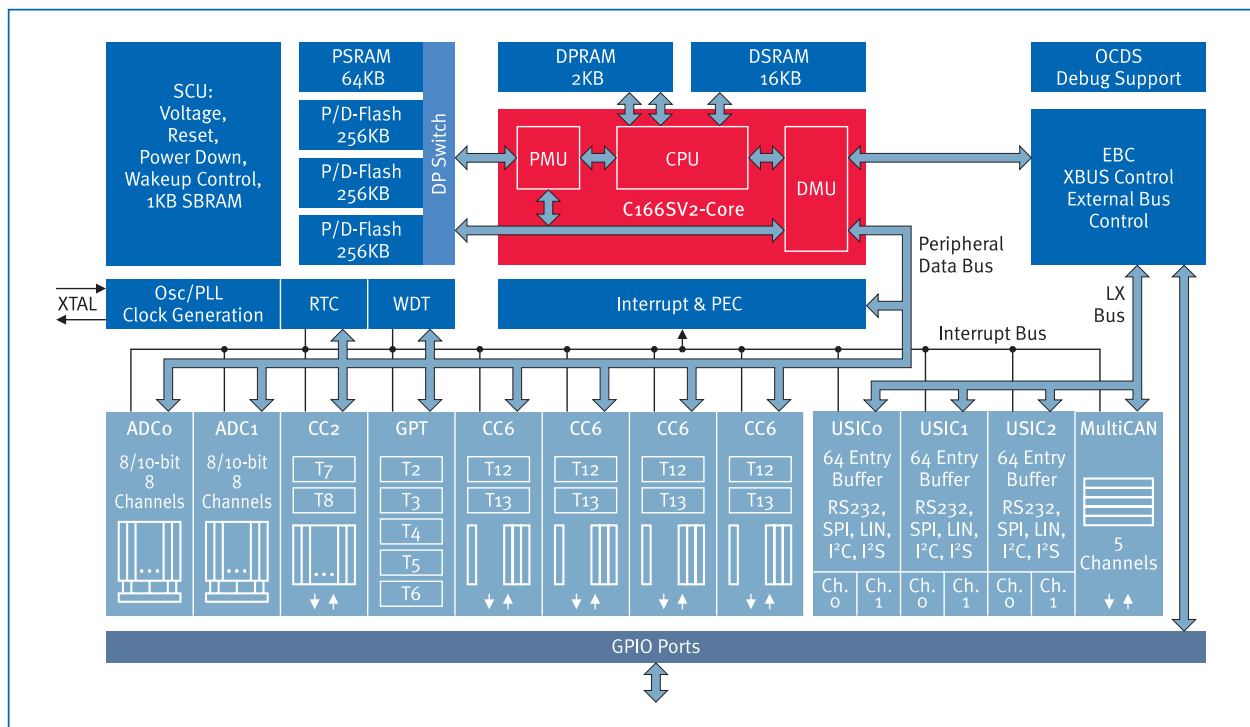

Application Example

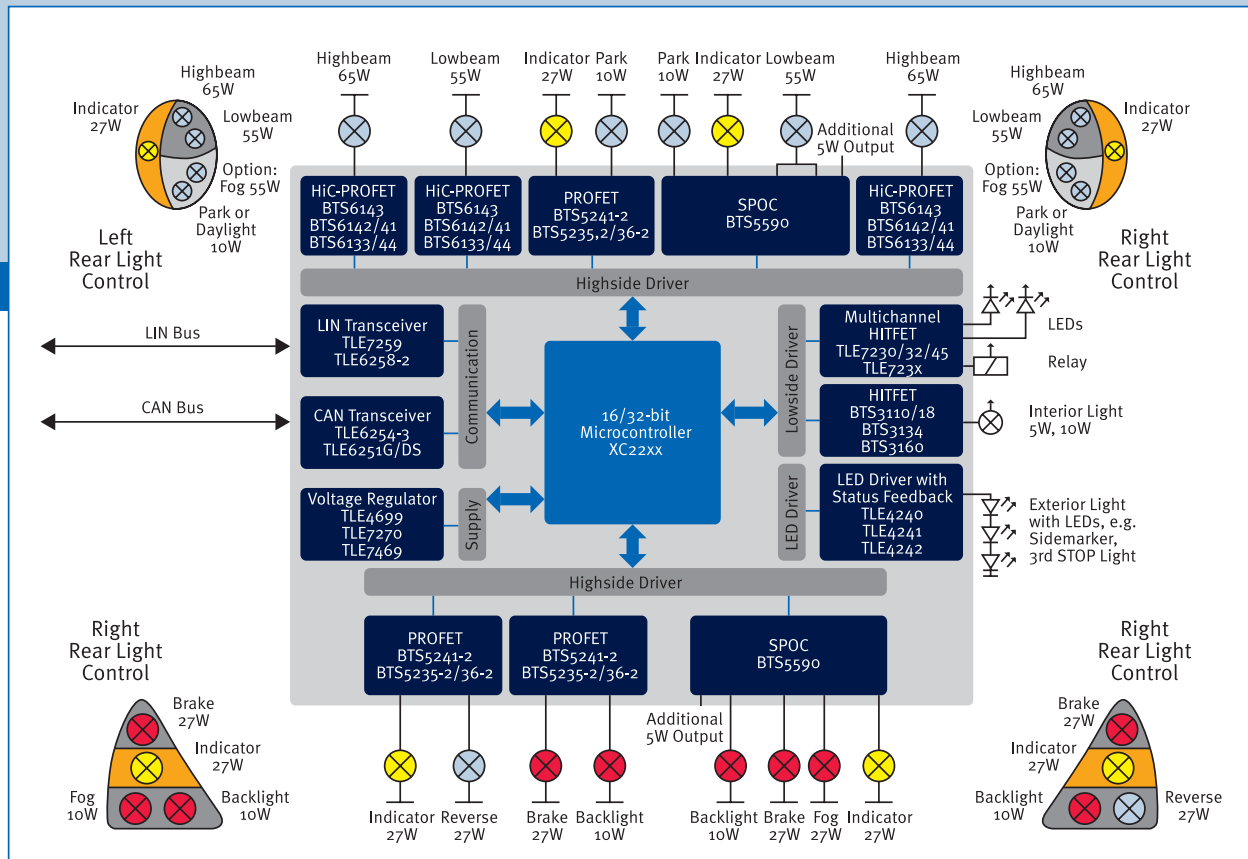

BCM & Gateway

BODY CONTROL MODULE (BCM) application comprising internal and external lighting systems, as well as car access and door modules with lighting, window lift, mirror positioning, refueling indicator for windscreen wipers and clock. The Central Gateway manages all internal interfaces (i.e. motor management, in-car entertainment, dashboard or convenience control) and communication with external interfaces for after-sales software updates.

Key Features

- 128–1600KB Flash with emulated EEPROM
- Up to 138KB SRAM
- Up to 6 CAN with 256 MO
- Up to 40 ADC channels
- Up to 48 PWM channels
- Up to 10 serial interfaces

Benefits

- Light bulb supervision without CPU load
- CAN gateway functionality without CPU load
- Fully scalable over package and memory
- Flexible power concept
- Memory protection unit (MPU) to fulfill AUTOSAR requirement



BCM & Gateway

Application Example

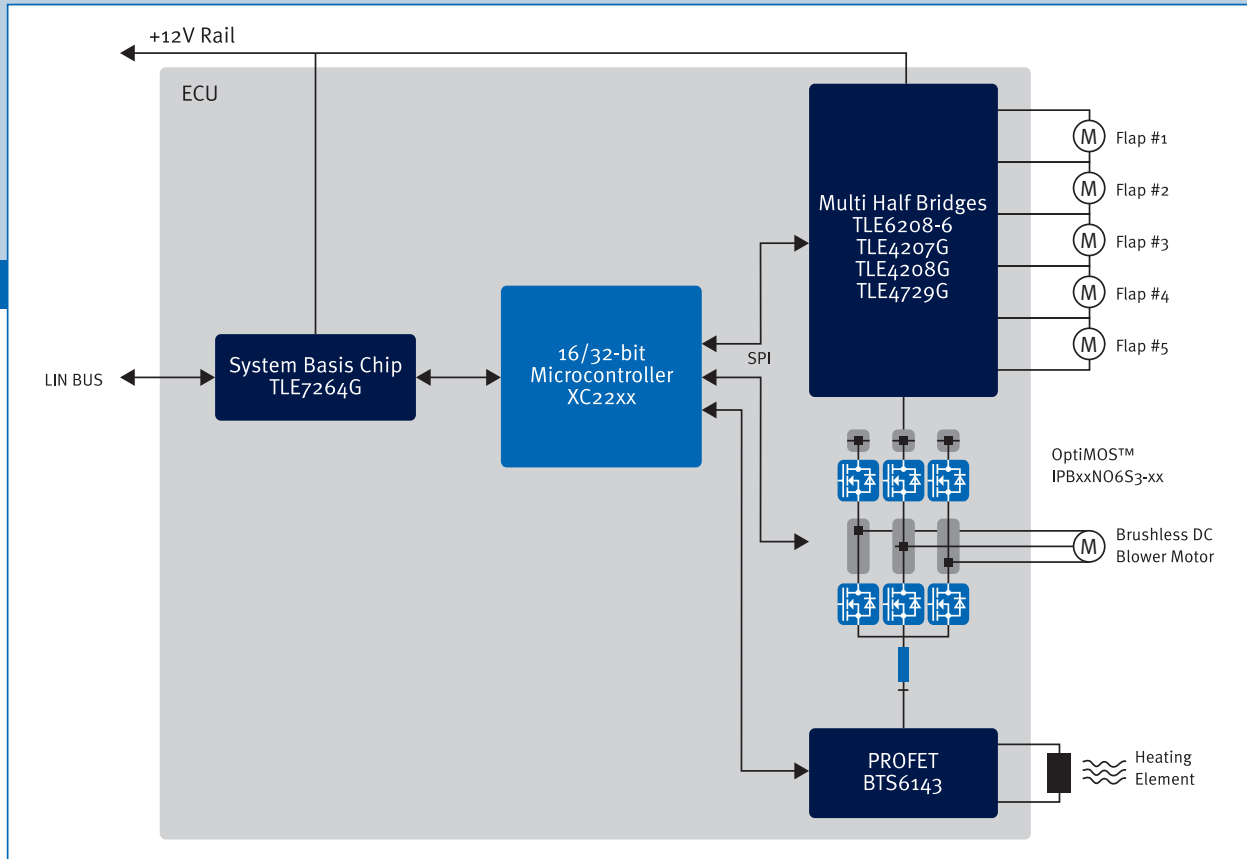

HVAC

BALANCING COMFORT AND FUEL efficiency is very important in automotive air conditioning. Reduced fuel consumption can be achieved by demand-oriented climate regulation. This could be covered by, for example, fresh air regulation (recirculating air operation) or the usage of brushless DC motors in fans.



Key Features

- 64–768KB Flash with emulated EEPROM
- Up to 3 CAN
- Up to 24 ADC channels with +/-2 LSB resolution
- Up to 32 PWM channels
- Up to 8 serial interfaces

Benefits

- CAN gateway functionality without CPU load
- Highly flexible serial interfaces (USIC), suitable as LIN, SPI, IIC, UART, IIS
- Fully scalable over package and memory
- High-performance CPU for ripple count algorithm

HVAC



XC2300

THE NEW XC2300 MICROCONTROLLER FAMILY is specifically designed for use in vehicle safety applications, targeting airbag systems and electronic power steering applications. The XC2300 family provides 32-bit performance and a rich peripheral feature set required for present and future safety applications demanding fast reaction time, redundancy and flexibility.

THE MEMBERS OF THE XC2300 FAMILY feature between 128KB and 1.6MB of Flash memory to fit both, e.g. airbag systems and highly complex safety-systems such as power steering, low-end chassis control and sensor clusters. Four different package options from 64-pin to 176-pin will be offered with a rich variety of features among others with integrated FlexRay™.

FOR SAFETY-CRITICAL APPLICATIONS such as airbags, steering or braking, the highest degree of reliability is an absolute must for all system components. All components of the XC2300 family are specifically designed to fulfill these strong safety requirements, and include a set of safety-relevant features, such as hardware error correction code (ECC) on all memories, memory protection, feature redundancy and several control mechanisms including cyclic redundancy code check (CRC). These features are essential for all XC2300 products to support and enable a system meeting the requirements of IEC 61508 (SIL3) or future ISO 26262 (ASILD).

Safety

XC2300

Product Portfolio

Type	eFlash [KB]	RAM [KB]	Serial Interfaces	CAN Nodes	FlexRay™	PWM Channels	ADC Channels	Package	Availability
XC2338B	128–320	10–34	4	2	no	24	8	PG-LQFP-64	2009
XC2363A/B	256–576	18–50	2	2	no	24	8	PG-LQFP-100	2008/2009
XC2364A/B	256–576	18–50	4	2	no	24	16	PG-LQFP-100	2008/2009
XC2365/A	256–576	18–50	6	3	no	24	16	PG-LQFP-100	Available/2008
XC2385A	384–576	18–50	4	2	no	24	16	PG-LQFP-144	2008
XC2387A/C	512–1088	26–122	6	3	no	24	24	PG-LQFP-144	Available/08/09
XC2388C	832–1600	50–138	8	3	yes	32	24	PG-LQFP-144	2009
XC2397C	832–1088	50–122	8	3	no	32	24	PG-LQFP-176	2009
XC2398C	832–1600	50–138	8	3	yes	32	24	PG-LQFP-176	2009

XC2300 Block Diagram (Example)

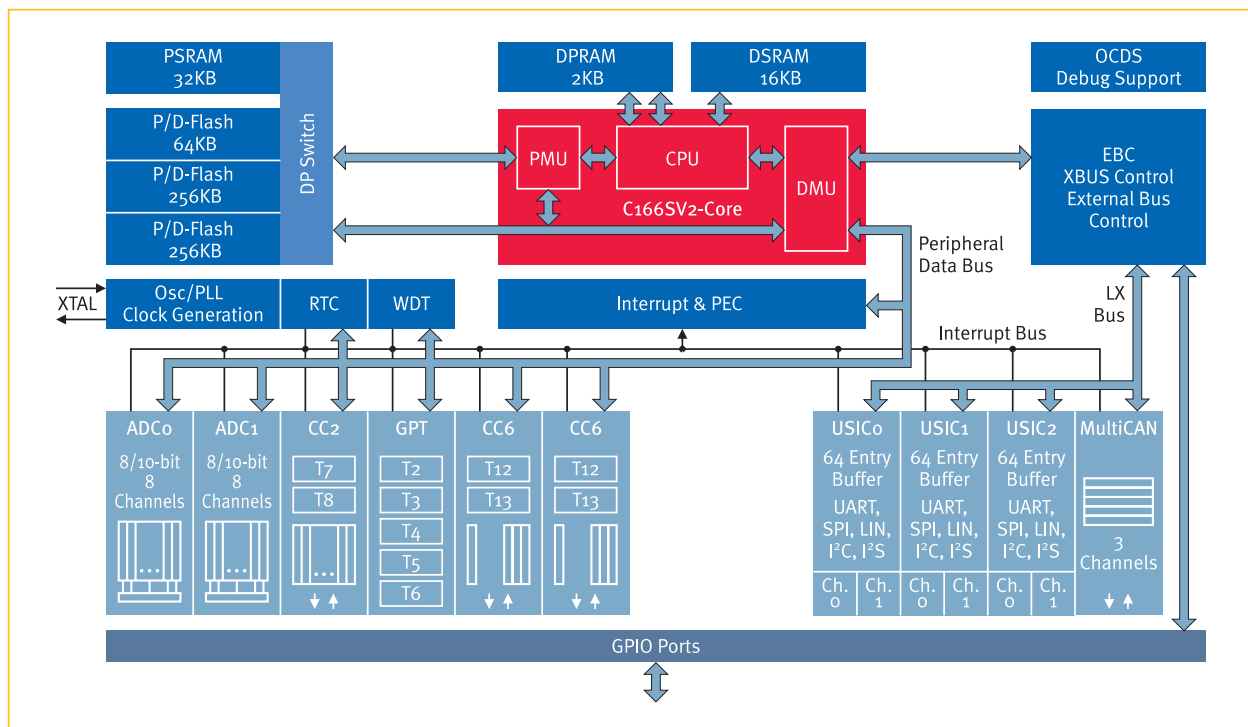

Application Example

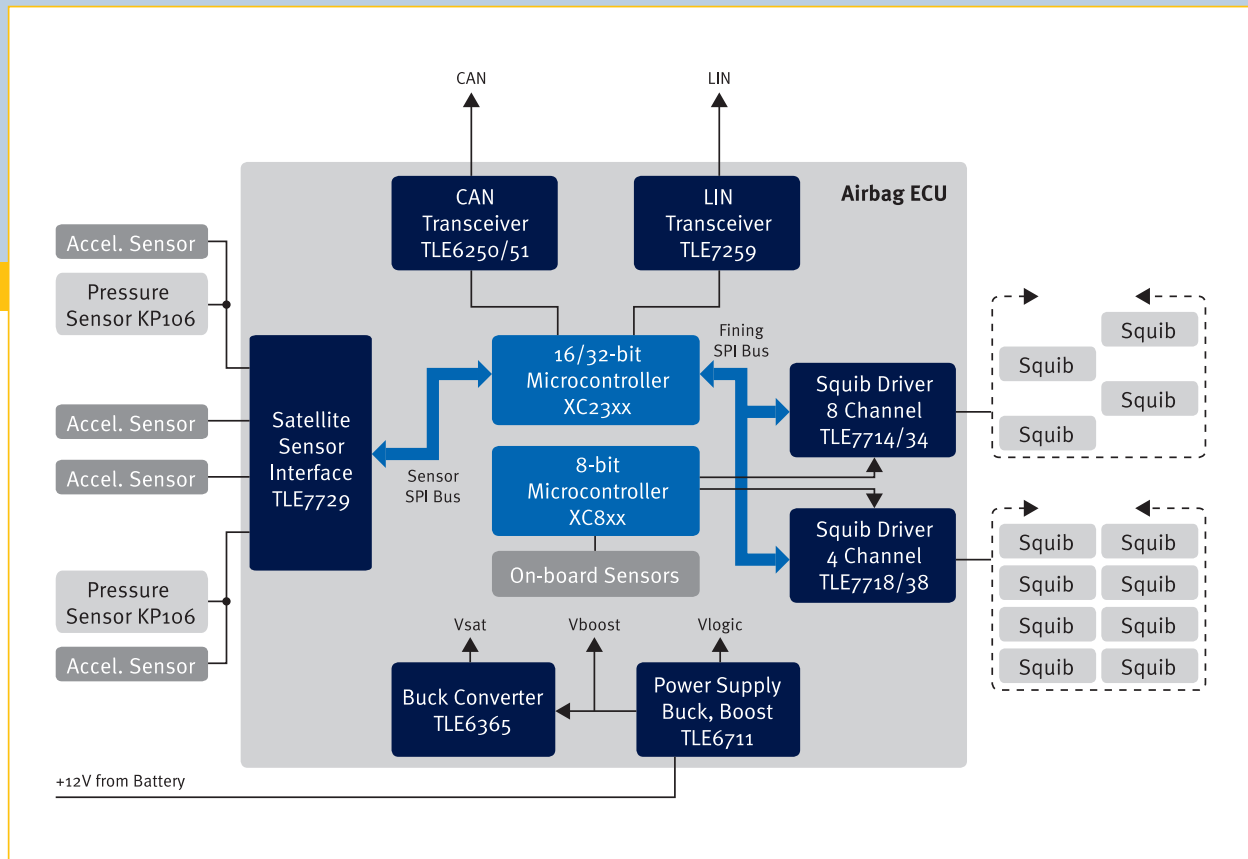

Airbag

THE XC2300 FAMILY OFFERS a perfect product fit for airbag applications. Its wide scalability and best price/performance ratio enables the system supplier to choose the cost optimized product, which fits best to the specific system requirements.

Key Features

- 128–768KB Flash with EEPROM emulation
- Up to 80KB SRAM
- Dual 10-bit ADC
- Up to 3 CAN, up to 6 serial interfaces
- FlexRay™ optional
- Dedicated safety features (MPU, CRC, ECC)
- 64-pin to 144-pin package

Benefits

- High scalability supports low-end to high-end airbag applications
- Excellent price/performance ratio
- EEPROM emulation enables event data recording, no external EEPROM needed
- Dedicated SAFETY concept to be prepared for SIL3/ASILD requirements
- Low power consumption (58mA @ 80MHz over full temperature range) enables system cost savings (e.g. in power supply circuits)



Airbag

Application Example

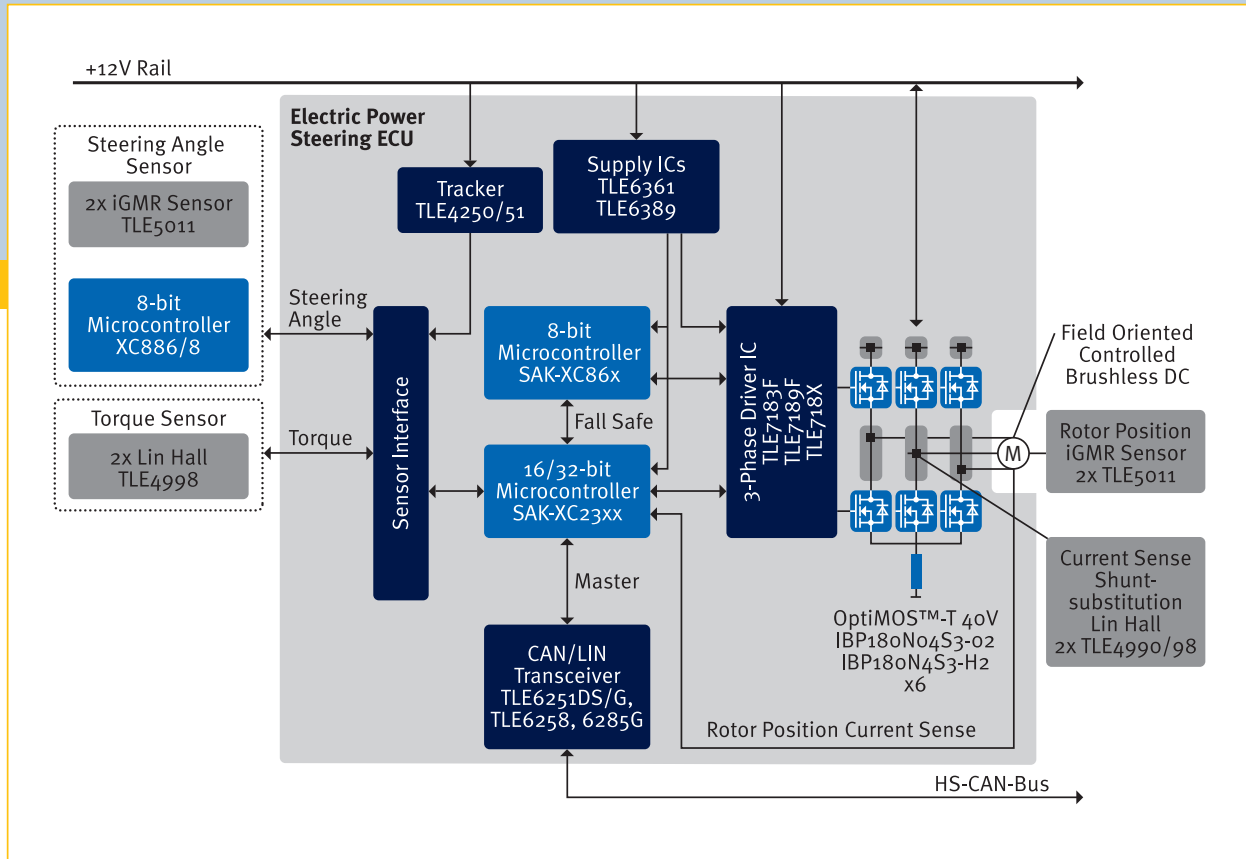

Electric Power Steering

THE VARIETY OF DIFFERENT electric power steering systems makes differing high demands on the performance and feature set of the microcontroller used in-system. The rich portfolio of the XC2300 family offers a cost-optimized fit for all system requirements, whether a simple EHPS system or a complex EPS application requiring high performance and specific interfaces such as FlexRay™.

Key Features

- Up to 100MHz system performance
- 256–1600KB Flash with EEPROM emulation
- Up to 138KB SRAM
- Dual ADC with highest resolution
- Up to 3 CAN, up to 8 serial interfaces
- FlexRay™
- Dedicated safety features (MPU, CRC, ECC)
- 100-pin to 176-pin package

Benefits

- High scalability enables optimized price-product choice
- Excellent price/performance ratio
- Dedicated SAFETY concept to be prepared for SIL3/ASILD requirements
- Low power consumption (58mA @ 80MHz over full temperature range) enables system cost savings (e.g. in power supply circuits)



EPS



XC2700

THE XC2700 FAMILY of microcontrollers with 32-bit performance will allow system makers to build cost effective electronic engine controls in motorcycles and entry-level automobiles around the world to meet coming emission standards.

THE XC2700 FAMILY is based on the industry-leading C166SV2 high performance microcontroller core with up to 100MHz. It also integrates key peripherals such as memory, voltage regulator and interfaces to reduce the overall system cost. This also means that software that has been developed on existing C166 controllers can be easily reused on the new family.

WITH 64 TO 176 PINS, the XC2700 family provides a scalable package range from lower-cost to higher-performance. Designers can easily move up and down the performance curve to design optimized engine control systems for motorcycles, entry-level cars as well as applications such as marine engines. Compatibility, scalability and a maximum re-use within the XC2700 family provides you with a variety of products and functions, covering today's, as well as future's application needs.

THE HIGH INTEGRATION AND PERFORMANCE of the XC2700 microcontroller family allows electronic engine control to be implemented in low-cost vehicles, providing more efficiency and significantly improved emissions. The XC2700 microcontroller is the perfect fit for value-driven powertrain applications.

THE LARGE RANGE OF AVAILABLE SUPPORT, tools and software as well as Infineon's extensive experience in powertrain applications allow you to achieve optimum time to market.

Powertrain

XC2700

Product Portfolio

Type	eFlash [KB]	RAM [KB]	Serial Interfaces	CAN Nodes	FlexRay™	PWM Channels	ADC Channels	Package	Availability
XC2797X	1600	138	8	2*	yes	32	40	PG-LQFP-176	2009
XC2787X	1600	138	8	2*	yes	32	24	PG-LQFP-144	2009
XC2786X	768-832	50	4	2*	no	24	24	PG-LQFP-144	Available/2008
XC2766X	768-832	50	4	2*	no	24	16	PG-LQFP-100	Available/2008
XC2785X	576	40	4	2*	no	24	24	PG-LQFP-144	2008
XC2765X	576	40	4	2*	no	24	16	PG-LQFP-100	2008
XC2735X**	576	40	4	2*	no	24	9	PG-LQFP-64	2008
XC2764X	320	32	4	2*	no	24	12	PG-LQFP-100	2009
XC2734X	320	32	4	2*	no	24	9	PG-LQFP-64	2009
XC2763X	128	16	4	2*	no	12	12	PG-LQFP-100	2010
XC2733X	128	16	4	2*	no	12	9	PG-LQFP-64	2010

* CAN are optional ** Limited to 85°C

XC2700 Block Diagram (Example)

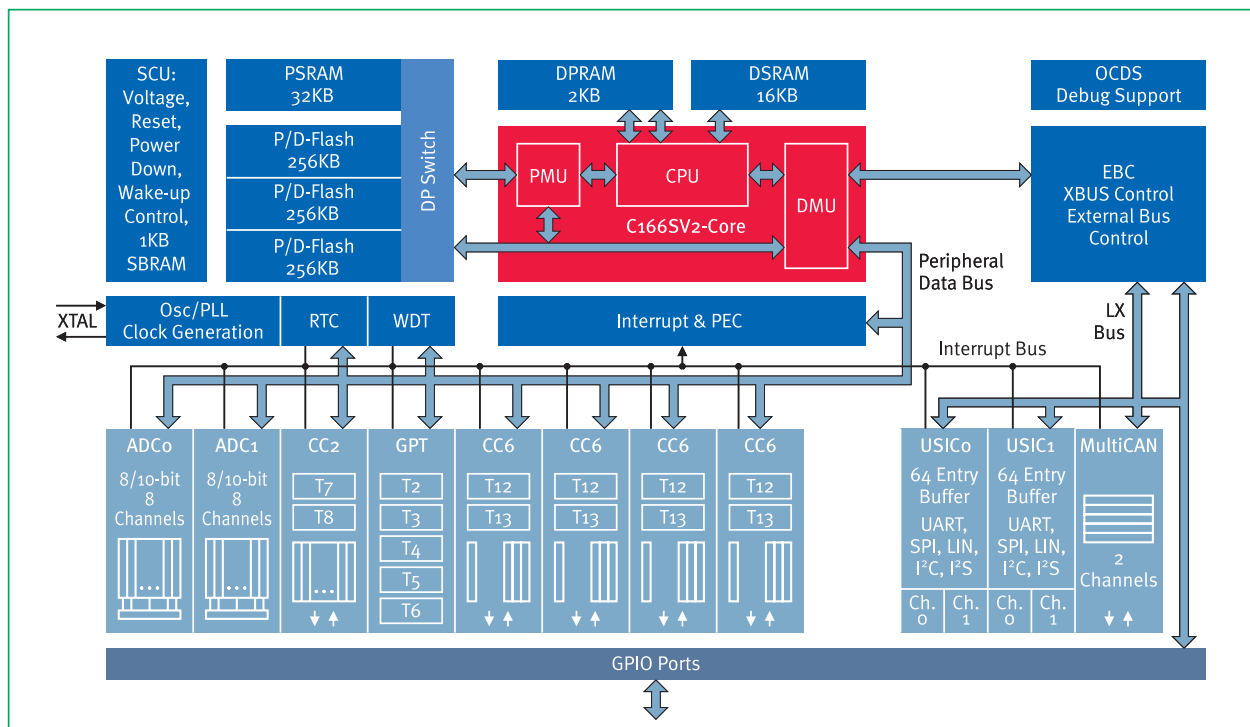

Application Example

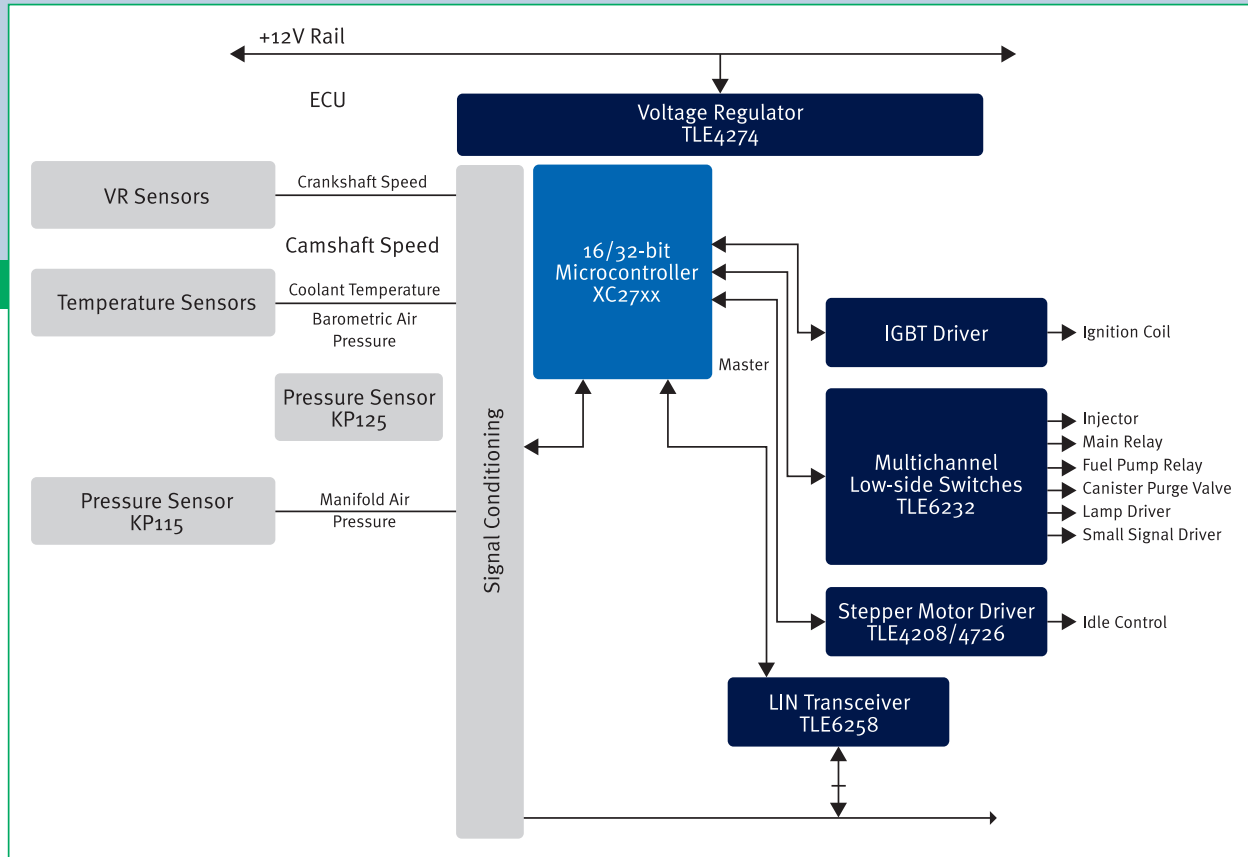

Engine Management for Motorcycles

THE NEXT GENERATION of motorcycles requires more functions to fulfill emission regulations, performance requirements and comfort expectations.

Key Features

- 40–100MHz CPU
- 128–1600KB Flash
- High flexible serial interfaces (USIC), suitable as LIN, SPI, IIC, UART, IIS
- On-chip MultiCAN interface
- Multi-functional general purpose timer
- Capture/compare units
- Synchronous A/D converters
- Single power supply
- 64-pin to 176-pin packages
- Temperature range: –40°C to +125°C

Benefits

- Scalable family, enabling value-driven 2/3/4-wheeler powertrain applications
- Based on industry-leading C166SV2 high-performance microcontroller core
- Supported by large range of development tools

Motorcycles

THE GLOBAL DRIVE FOR EMISSION reduction will also affect the two-wheeler market and entry level cars market. With the XC2700 family you are choosing modern and future oriented microcontrollers dedicated to powertrain applications.

CURRENT SYSTEMS IN AUTOMOTIVE provide an accurate, reliable and cost-effective method of metering fuel and providing maximum engine efficiency with clean exhaust emissions, which is why electronic fuel injection (EFI) systems have replaced carburetors in the marketplace. EFI is becoming more reliable and less expensive through widespread usage. At the same time, carburetors are becoming less available and more expensive. Even marine applications are adopting EFI as reliability improves. Virtually all internal combustion engines, including motorcycles, off-road vehicles, and outdoor power equipment may eventually use some form of fuel injection. The XC2700 product family supports all features for a reliable and cost-effective system.

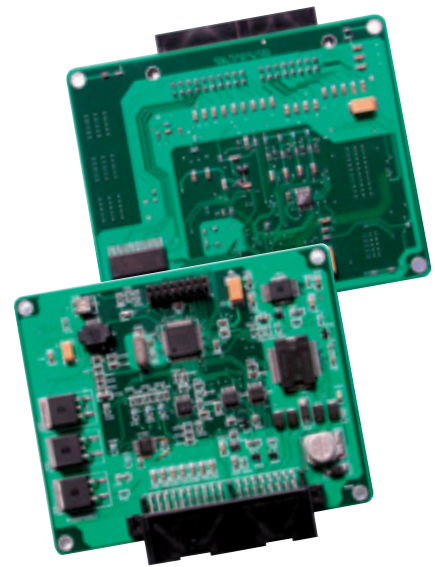

XC2700 features offer the perfect fit to increase efficiency, to reduce emission and to improve comfort.

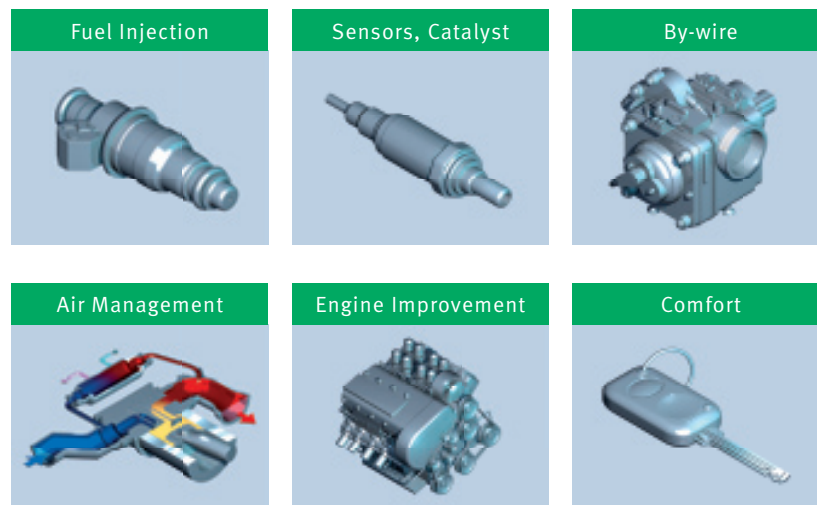

Enhanced Communication

Enhanced Communication

MultiCAN

COMPLEX APPLICATIONS increasingly require intelligent communication over the CAN network. A CAN gateway and a FIFO are only two examples of what can easily be implemented with XC2000's enhanced MultiCAN module.

MultiCAN Features

- Full CAN with CAN 2.0B active
- Up to 6 independent CAN nodes
- Up to 256 message objects
- Programmable acceptance filtering
- Data transfer rate up to 1Mbit/s, individually programmable for each node
- Powerful analysis capability
- FIFO data handling support
- Automatic gateway support
- Flexible interrupt handling

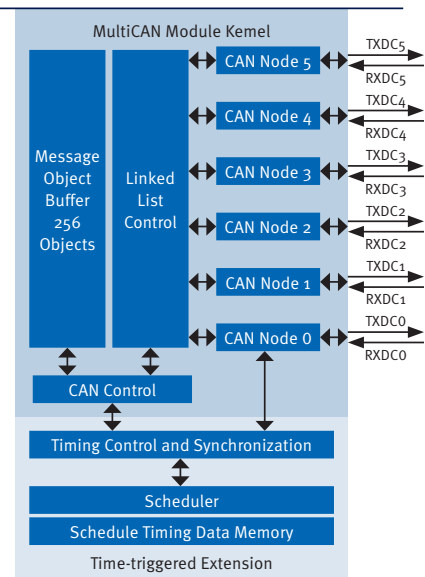

Universal Serial Interface (USIC)

Each USIC Channel

- Is capable of handling UART, SPI, LIN, IIC and IIS
- Is individually configurable (incl. baud rate generation)
- Handles full duplex data transfers
- Has programmable Rx and Tx FIFOs
- Can be reprogrammed on the fly without chip reset

A USIC Module

- Is a cluster of 2 independent, identical USIC channels
- Up to 5 USIC modules available (=10 channels)

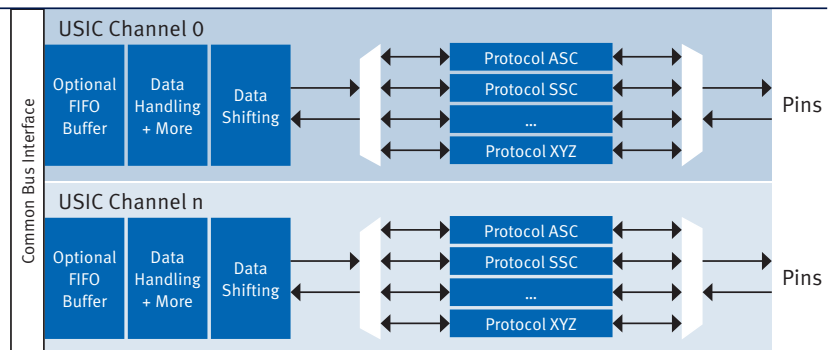

DESIGNERS CAN NOW CONFIGURE universal serial interfaces depending on their system's requirements. Whether UART, SSC (SPI compatible), LIN, IIC or IIS, any interface is possible after a quick adjustment of the USIC module.

FlexRay™

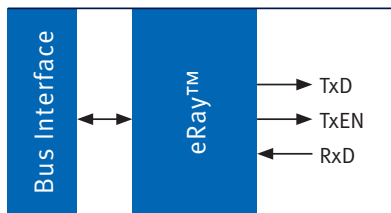

Constant Current Supply

- Embedded FlexRay™ module available in 2009
- Module based on Bosch eRay™ 1.0.2
- Follows latest FlexRay™ specification 2.1
- Flexible operation features
- Support of 16/32-bit adaption
- Support of XC2000 PEC

Scalable Integrated & Discrete Solutions

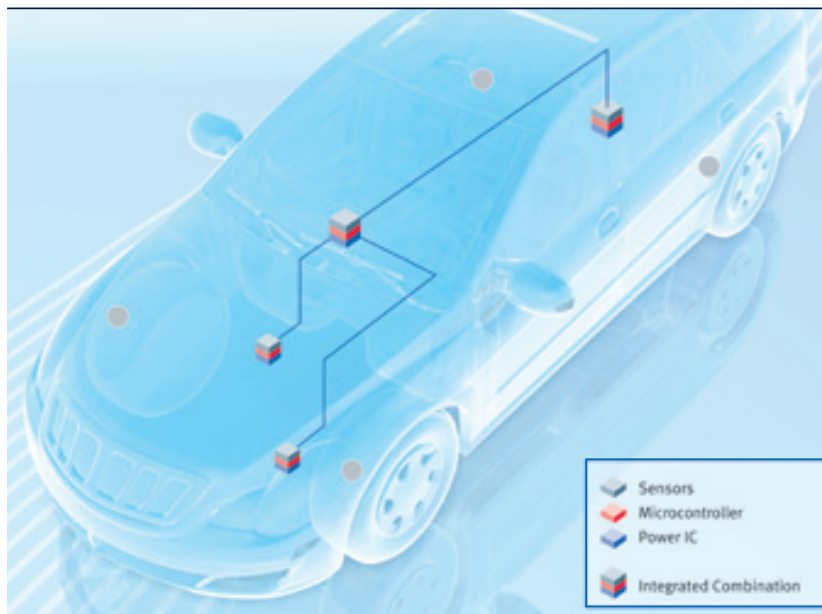

Discrete FlexRay™ Solutions

Infineon CIC-310 – FlexRay™ Companion IC – Fits Perfectly With

Infineon XC2200 Microcontrollers

- Power-down features and communication interface options for body applications

Infineon XC2300 Microcontrollers

- Safety features and redundancies for safety-relevant applications such as power steering and airbag

Infineon XC2700 Microcontrollers

- Powerful motor control features for low-end engine control

Integrated FlexRay™ Solutions

XC2000 Fully Integrated, Most Powerful Automotive Microcontroller

- Up to 100MHz
- FlexRay™ integrated
- Up to 1.6MB eFlash
- XC2200 optimized for high-end body applications, XC2300 optimized for safety, XC2700 optimized for low-end engine control

Peripheral

Peripheral Highlights

CCU6E – High-performance PWM

CONSISTS OF A 16-BIT timer block (T12) with three capture/compare channels and another 16-bit timer block (T13) with one compare channel. The T12 channels can generate up to 6 PWM signals or accept up to 6 capture triggers. The T12 channels can be used to control up to 3 half-bridges with automatic dead-time generation. They can jointly generate control signal patterns to drive AC motors or inverters. Sinusoidal or space vector modulation can be easily implemented. Special operating modes support the control of brushless DC motors using Hall sensors or back EMF detection. In addition, block commutation and control mechanisms for multi-phase machines are supported.

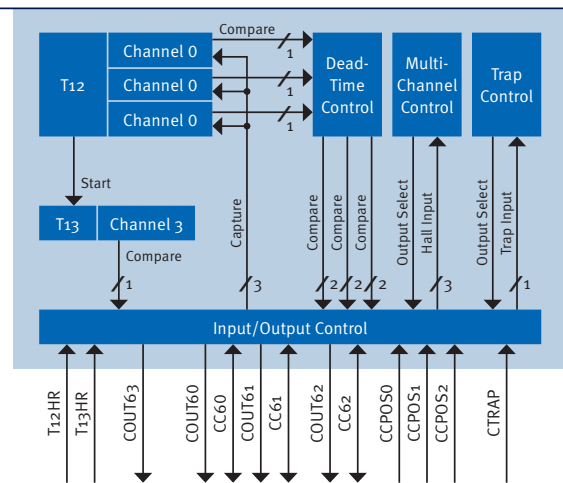

CCU6E Features

- Capture for time measurement
- Compare for PWM generation
- Burst for additional modulation
- Single-shot for flexible signal generation
- Multi-channel for unipolar machines
- Block commutation for brushless DC drives

Enhanced Analog-Digital Converter (ADC)

2 Synchronizable A/D Converters With

- Total of up to 40 channels
- 10-bit resolution, +/-2 LSB
- Conversion time down to 1.2µs
- Data reduction pre-processing
- Result accumulation, limit check
- External or internal trigger events and automatic conversion sequencing

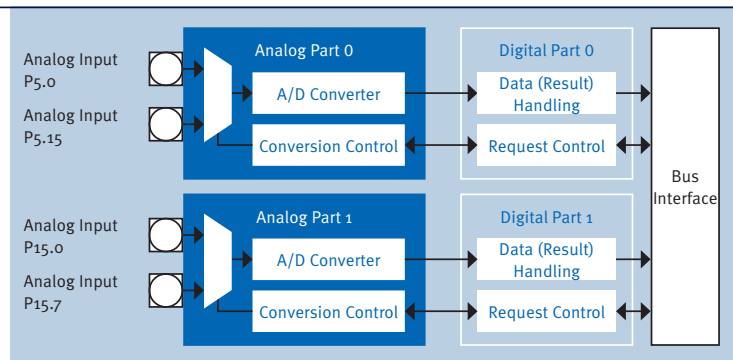

Highlights

AUTOSAR

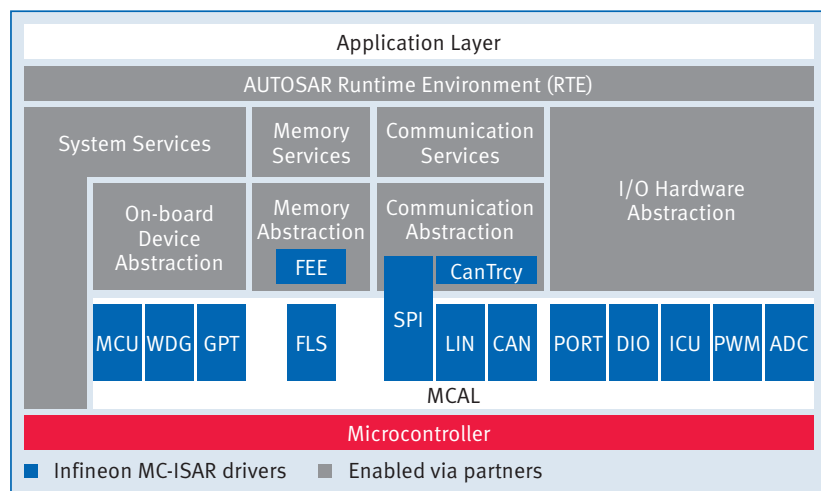

AUTOSAR

Infineon...

- Has been contributing to AUTOSAR since 2004
- Provides AUTOSAR solutions for its microcontrollers
- Offers AUTOSAR-compliant low-level drivers: MC-ISAR
- Enables partners to provide the complete AUTOSAR basic software

Infineon Product Families Supported

- XC2200
- XC2300
- XC2700

Oriented to Automotive

- Early implementation of MC-ISAR in 2005
- MC-ISAR will be implemented for additional microcontrollers
- CMM level3 certified and standardized software process applied
- Microcontroller modules designed for flexible configuration via AUTOSAR

Development Tools

XC2000 Integrated Compiler Development Environment



Emulator/Debugger Development Systems



Programmer/Programming Software



Operating System & Software



Simulation/Modelling



Auto Code Generation Tools



Starter Kits and Evaluation Boards



Published by
Infineon Technologies AG
81726 Munich, Germany
© 2008 Infineon Technologies AG.
All rights reserved.

Legal Disclaimer

The information given in this document shall in no event be regarded as a guarantee of conditions or characteristics. With respect to any examples or hints given herein, any typical values stated herein and/or any information regarding the application of the device, Infineon Technologies hereby disclaims any and all warranties

and liabilities of any kind, including without limitation warranties of non-infringement of intellectual property rights of any third party.

Information

For further information on technology, delivery terms and conditions and prices, please contact the nearest Infineon Technologies Office (www.infineon.com).

Warnings

Due to technical requirements, components may contain dangerous substances. For information on the types in question, please contact the

nearest Infineon Technologies Office. Infineon Technologies components may be used in life-support devices or systems only with the express written approval of Infineon Technologies, if a failure of such components can reasonably be expected to cause the failure of that life-support device or system or to affect the safety or effectiveness of that device or system. Life support devices or systems are intended to be implanted in the human body or to support and/or maintain and sustain and/or protect human life. If they fail, it is reasonable to assume that the health of the user or other persons may be endangered.

INFINEON TECHNOLOGIES SALES OFFICES WORLDWIDE*

(COUNTRY/AREA)

Australia

Infineon Technologies Australia Pty. Ltd.
885 Mountain Highway
Bayswater, Victoria 3153
☎ (+61) 3-97 21 88 88
Fax (+61) 3-97 21 88 08

Austria

Infineon Technologies Austria AG
Production/Development Center
Siemensstraße 2
9500 Villach
☎ (+43) 5-17 77 0
Fax (+43) 5-17 77 35 01

Infineon Technologies Austria AG
Opengasse 20B/31
1040 Wien
☎ (+43) 1-51 77 71 11 00
Fax (+43) 1-51 77 71 15 00

Belgium/Luxembourg Netherlands

Infineon Technologies Holding B.V.
Generaal
Lemanstraat 67
2018 Antwerpen
☎ (+31) 10-21 76 80 0
Fax (+31) 10-21 76 81 9

Infineon Technologies Holding B.V.
Westblaak 32
3012 KM Rotterdam
☎ (+31) 10-21 76 80 0
Fax (+31) 10-21 76 81 9

Brazil

Infineon Technologies
South America Ltda.
Avenida Paulista
n° 1337-Cj 172
**01311-200 Cerqueira Cesar
São Paulo**
☎ (+55) 11-33 72 92 40
Fax (+55) 11-33 72 92 30

Canada

Infineon Technologies
North America Corp.
240 March Road, Suite 301
Kanata, Ontario K2K 2E2
☎ (+1) 866-95 19 51 95 1
Fax (+1) 613-59 18 95 4

China

Infineon Technologies
Center of Competence (Shanghai) Co., Ltd.
12th Floor, Quantum Plaza
No.27 Zhi Chun Road
Haidian District
Beijing 100083
☎ (+86) 10-82 35 61 18
Fax (+86) 10-82 35 54 74

Infineon Technologies
Hong Kong Ltd.
Suite 302, Level 3 Festival Walk
80 Tat Chee Avenue
Kowloon Tong
Hong Kong
☎ (+852) 28-32 05 00
Fax (+852) 28-27 97 62

Infineon Technologies
International Trade (Shanghai) Co., Ltd.
No. 7 & 8, Lane 647, Song Tao Road
Zhang Jian Hi-Tech Park
Shanghai 201203
☎ (+86) 21-61 01 90 00
Fax (+86) 21-50 80 62 04

Infineon Technologies AG
Lindenplatz 2
20099 Hamburg
☎ (+49) 40-23 51 94 74
Fax (+49) 40-23 51 94 75

Infineon Technologies
China Co., Ltd.
Shenzhen Office, Room 1502, Block A
Tian An International Building
Renmin Nan Road
Shenzhen 518 001
☎ (+86) 755-22 19 24 00
Fax (+86) 755-82 28 02 17

Infineon Technologies
Taiwan Co., Ltd.
12F-1, No. 3-2 Yuan Qu Street
Nan Kang District
Taipei 115
☎ (+886) 2-26 55 75 00
Fax (+886) 2-26 55 75 01 8

Denmark

Infineon Technologies Nordic AB
Herlev Hovedgade 201A
2730 Herlev
☎ (+45) 44-50 77 00
Fax (+45) 44-50 77 01

Finland

Infineon Technologies Nordic AB
Visitor's Address Upseerinkatu 1
P.O. Box 276
02601 Espoo
☎ (+358) 10-6 80 84 00
Fax (+358) 10-6 80 84 01

France

Infineon Technologies France S.A.S.
Centre de vie Agora – Bat. Az
Z.I. des Paluds
13400 Aubagne
☎ (+33) 44-28 24 61 0
Fax (+33) 44-28 24 61 8

Infineon Technologies France S.A.S.
Burlonnes 2
2 ter, rue Marcel Doret
37100 Blagnac
☎ (+33) 5-34 55 13 30
Fax (+33) 5-34 55 13 34

Infineon Technologies France S.A.S.
39-47, Boulevard Ornano
93527 Saint-Denis CEDEX 2
☎ (+33) 1-48 09 72 00
Fax (+33) 1-48 09 72 90

Germany

Comneon GmbH
Südwestpark 2-4
90449 Nuremberg
☎ (+49) 911-37 88 0
Fax (+49) 911-37 88 10 00

Hitec Development Tools GmbH
Greschbachstraße 12
76229 Karlsruhe
☎ (+49) 72-19 62 80
Fax (+49) 72-19 62 81 89

Infineon Technologies AG
Siemensstraße 31-33
71254 Ditzingen/Stuttgart
☎ (+49) 7156-17 91 90
Fax (+49) 7156-17 91 99 0

Infineon Technologies AG
Düsseldorfer Landstraße 401
47259 Duisburg
☎ (+49) 203-72 98 71 1
Fax (+49) 203-72 98 76 0

Infineon Technologies AG
Naegelsbacherstraße 26
91052 Erlangen
☎ (+49) 9131-97 00 10
Fax (+49) 9131-97 00 19 9

Infineon Technologies AG
Lindenplatz 2
20099 Hamburg
☎ (+49) 40-23 51 94 74
Fax (+49) 40-23 51 94 75

Infineon Technologies AG
Paderborner Straße 1
30539 Hannover
☎ (+49) 511-87 65 62 0
Fax (+49) 511-87 65 62 00

Infineon Technologies AG
Am Campeon 1-12
85579 Neubiberg
☎ (+49) 89-23 40
Fax (+49) 89-23 42 46 94

Infineon Technologies AG
Südwestpark 65
90449 Nuremberg
☎ (+49) 911-25 29 30
Fax (+49) 911-25 29 39 3

Infineon Technologies AG
Max-Planck-Straße 5
59581 Warstein
☎ (+49) 2902-76 40
Fax (+49) 2902-76 41 25 6

Hungary

Infineon Technologies Cegléd Kft.
Gizella u. 51-57
1143 Budapest
☎ (+36) 1-47 12 82 4
Fax (+36) 1-47 12 82 5

India

Infineon Technologies India Pvt. Ltd.
10th Floor, Discoverer Building
International Technology Park
Whitefield Road
Bangalore 560 066
☎ (+91) 80-41 39 20 01
Fax (+91) 80-41 39 23 33

Iran

Siemens SSK
No. 32 Taleghani Ave.
15875-473 Teheran
☎ (+98) 2-16 14 23 17
Fax (+98) 2-16 46 30 60

Ireland

Infineon Technologies Ireland Ltd.
69 Fitzwilliam Lane
Dublin 2
☎ (+353) 1-79 99 50 0
Fax (+353) 1-79 99 50 1

Israel

Nisko Ltd.
2A, Habarzel Street
Tel Aviv 69710
☎ (+972) 3-76 57 30 0
Fax (+972) 3-76 57 33 3

Italy

Infineon Technologies Italia S. r. l.
Via Vipiteno, 4
20128 Milan
☎ (+39) 2-25 20 41
Fax (+39) 2-25 20 44 39 5

Japan

Infineon Technologies Japan K. K.
Maruyama Nissei Building 14F
2-14-21 Nishiki, Naka-ku
Nagoya-shi, Aichi 460-0003
☎ (+81) 52-22 31 57 0
Fax (+81) 52-22 31 46 1

Infineon Technologies Japan K. K.
ORIX-Dojima Building 8F
2-1-31, Dojima, Kita-ku
Osaka-shi
Osaka 530-0003
☎ (+81) 6-47 97 44 60
Fax (+81) 6-47 97 44 62

Infineon Technologies Japan K.K.
Gate City Osaka, East Tower
21F/22F/23F
1-11-2 Osaki
Shinagawa-ku
Tokyo 141-0032
☎ (+81) 3-57 45 71 00
Fax (+81) 3-57 45 74 10

Korea

Infineon Technologies Korea Co., Ltd.
4th Floor Sigma Tower
7-19 Shincheon-dong Songpa-gu
Seoul 138-734
☎ (+82) 2-34 60 09 50
Fax (+82) 2-34 60 09 01

Infineon Technologies Korea Co., Ltd.
15th Floor SJ Technoville 60-19
Gasan-dong Geumcheongu
Seoul 153-801
☎ (+82) 2-34 60 08 80
Fax (+82) 2-34 60 09 09

Mexico

Everest Sales & Solutions
Av. Manuel Acuña 2674-101
Col. Ladrón de Guevara
44680 Guadalajara, J. AL
☎ (+52) 33-36 42 21 01
Fax (+52) 33-36 40 65 62

Poland

Siemens Sp. z o.o.
Ul. Zupnicza 11
03-821 Warsaw
☎ (+48) 22-87 09 15 0
Fax (+48) 22-87 09 15 9

Puerto Rico

Klamco Electronics
527 Street QH No. 1
Country Club
Carolina, PR 00982
☎ (+1787) 257-79 22
Fax (+1787) 257-79 61

Russia

Infineon Technologies RUSS LLC
Leninsky prospect 113/1
117 198 Moscow
☎ (+7) 495-95 65 19 5
Fax (+7) 495-95 65 19 5

Singapore

Infineon Technologies Asia
Pacific Pte. Ltd.
8 Kallang Sector
Singapore 349 282
☎ (+65) 68-76 28 88
Fax (+65) 68-76 31 22

South Africa

Siemens Components
P.O. Box 3438
Halfway House 1680
2146 Sandton
☎ (+27) 11-70 66 09 9
Fax (+27) 11-70 69 04 9

Spain

Infineon Distribution Sales Office IBERIA
c/ Chile, 10 1a Planta – Oficina 141
Edificio Madrid 92
28290 Las Rozas de Madrid, Madrid
☎ (+34) 91-63 05 72 8
Fax (+34) 91-63 05 72 8

Siemens, S.A.
División de Componentes
Ronda de Europa, 5
28760 Tres Cantos-Madrid
☎ (+34) 91-51 47 15 5
Fax (+34) 91-51 47 01 4

Sweden

Infineon Technologies Sweden AB
Isafjordsgatan 16
16481 Kista
☎ (+46) 8-75 75 00 0
Fax (+46) 8-75 74 61 2

Switzerland

Infineon Technologies Schweiz AG
Badener Strasse 623
P.O. Box 1570
8048 Zurich
☎ (+41) 1-49 78 04 0
Fax (+41) 1-49 78 05 0

Turkey

Infineon Technologies Turkey
Şehit Mehmet Fatih Ongul Sok.
Bagdatlioglu Plaza No:3
Office:4 Kozyatagi
34742 Kozyatagi, Istanbul
☎ (+90) 216-46 40 75 5
Fax (+90) 216-46 40 75 6

United Kingdom

Infineon Technologies
Kingswood
Kings Ride
Ascot SL5 8AD
☎ (+44) 1344-86 59 00

Infineon House
Great Western Court
Hunts Ground Road
Stoke Gifford
Bristol BS34 8HP
☎ (+44) 11-79 52 88 23

U.S.A.

Infineon Technologies
North America Corp.
2529 Commerce Drive, Suite H
Kokomo, IN 46902
☎ (+1) 765-45 61 92 8
Fax (+1) 765-45 63 83 6

Infineon Technologies
Industrial Power, Inc.
1050 Route 22
Lebanon, NJ 08833
☎ (+1) 908-23 65 62 1
Fax (+1) 908-23 65 62 0

Infineon Technologies
North America Corp.
1880 W. Winchester Drive, Suite 108
Libertyville, IL 60048
☎ (+1) 847-99 60 48 0

Infineon Technologies
North America Corp.
19111 Victor Parkway
Livonia, MI 48152
☎ (+1) 734-77 95 00 0
Fax (+1) 734-77 95 00 1

Infineon Technologies
North America Corp.
640 N. McCarthy Blvd.
Milpitas, CA 95035
☎ (+1) 866-95 19 51 9

Infineon Technologies
North America Corp.
12770 High Bluff Drive, Suite 100
San Diego, CA 92130
☎ (+1) 858-50 92 16 0
Fax (+1) 858-50 92 16 1

* and representative offices

www.infineon.com

Published by Infineon Technologies AG

Order No. B158-H9148-X-X-7600