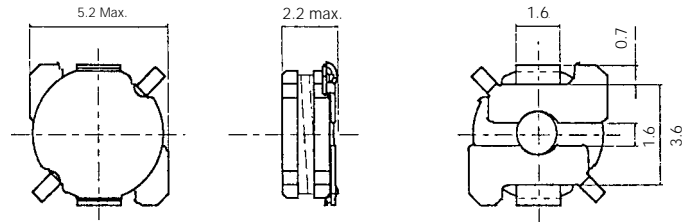

TYPE D52FU
Frequency Range: 10kHz - 1MHz

Inductance Range: 470 μ H - 6.8mH

 Tolerance: ± 0.2
 Unit: mm
Features

- Low profile (2.2mm max. height) and 5.2mm square
- Ideal for IC inverter EL lamp driver applications
- Available on tape and reel for auto-insertion
- Suitable for reflow soldering

STANDARD PARTS SELECTION GUIDE

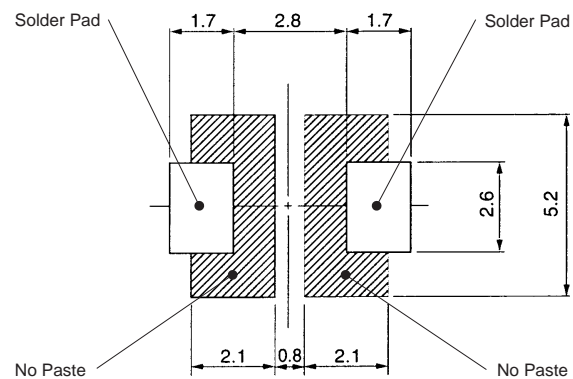
- (1) Inductance is measured by LCR-meter 4284A (HP) or equivalent.
- (2) DC Resistance is measured by Digital Multimeter TR6871 (Advantest) or equivalent.
- (3) Maximum allowable DC current is that which causes a 10% inductance reduction from the initial value, or coil temperature to rise by 40°C, whichever is smaller. (Reference ambient temperature 20°C).

Recommended patterns:

Unit: mm

TYPE D52FU

TOKO Part Number	Inductance ⁽¹⁾ (μ H) $\pm 20\%$	Rated DC ⁽²⁾ Resistance (Ω) max.	Rated ⁽³⁾ DC Current (mA) max.
875FU-471M=P3	470	8.1	140
875FU-561M=P3	560	11	125
875FU-681M=P3	680	13	115
875FU-821M=P3	820	15	105
875FU-102M=P3	1000	20	95
875FU-122M=P3	1200	22	88
875FU-152M=P3	1500	27	83
875FU-182M=P3	1800	33	74
875FU-222M=P3	2200	39	64
875FU-272M=P3	2700	45	61
875FU-332M=P3	3300	62	50
875FU-392M=P3	3900	71	50
875FU-472M=P3	4700	96	42
875FU-562M=P3	5600	110	40
875FU-682M=P3	6800	130	37

Note: =P3 is added to each part number to indicate tape and reel packaging.