

8-Bit

SAA-XC886CLM

8-Bit Single Chip Microcontroller

Data Sheet

V1.1 2010-08

Microcontrollers

Edition 2010-08

**Published by
Infineon Technologies AG
81726 Munich, Germany**

**© 2010 Infineon Technologies AG
All Rights Reserved.**

Legal Disclaimer

The information given in this document shall in no event be regarded as a guarantee of conditions or characteristics. With respect to any examples or hints given herein, any typical values stated herein and/or any information regarding the application of the device, Infineon Technologies hereby disclaims any and all warranties and liabilities of any kind, including without limitation, warranties of non-infringement of intellectual property rights of any third party.

Information

For further information on technology, delivery terms and conditions and prices, please contact the nearest Infineon Technologies Office (www.infineon.com).

Warnings

Due to technical requirements, components may contain dangerous substances. For information on the types in question, please contact the nearest Infineon Technologies Office.

Infineon Technologies components may be used in life-support devices or systems only with the express written approval of Infineon Technologies, if a failure of such components can reasonably be expected to cause the failure of that life-support device or system or to affect the safety or effectiveness of that device or system. Life support devices or systems are intended to be implanted in the human body or to support and/or maintain and sustain and/or protect human life. If they fail, it is reasonable to assume that the health of the user or other persons may be endangered.

8-Bit

SAA-XC886CLM

8-Bit Single Chip Microcontroller

Data Sheet

V1.1 2010-08

Microcontrollers

SAA-XC886 Data Sheet**Revision History: V1.1 2010-08**

Previous Versions: V1.0 2009-09

Page	Subjects (major changes since last revision)
126	New parameter on weighted average temperature is added.
126	Maximum value of parameter V_{CDM} is increased from 500 V to 750 V.
126	Parameter V_{CDM} is no longer differentiated between V_{DDC} and all other pins.

We Listen to Your Comments

Any information within this document that you feel is wrong, unclear or missing at all?
Your feedback will help us to continuously improve the quality of this document.

Please send your proposal (including a reference to this document) to:

mcdocu.comments@infineon.com



Table of Contents

1	Summary of Features	1
2	General Device Information	4
2.1	Block Diagram	4
2.2	Logic Symbol	5
2.3	Pin Configuration	6
2.4	Pin Definitions and Functions	7
3	Functional Description	16
3.1	Processor Architecture	16
3.2	Memory Organization	17
3.2.1	Memory Protection Strategy	18
3.2.1.1	Flash Memory Protection	18
3.2.2	Special Function Register	20
3.2.2.1	Address Extension by Mapping	20
3.2.2.2	Address Extension by Paging	22
3.2.3	Bit Protection Scheme	26
3.2.3.1	Password Register	27
3.2.4	SAA-XC886 Register Overview	28
3.2.4.1	CPU Registers	28
3.2.4.2	MDU Registers	29
3.2.4.3	CORDIC Registers	30
3.2.4.4	System Control Registers	31
3.2.4.5	WDT Registers	33
3.2.4.6	Port Registers	34
3.2.4.7	ADC Registers	36
3.2.4.8	Timer 2 Registers	40
3.2.4.9	Timer 21 Registers	40
3.2.4.10	CCU6 Registers	41
3.2.4.11	UART1 Registers	45
3.2.4.12	SSC Registers	46
3.2.4.13	MultiCAN Registers	46
3.2.4.14	OCDS Registers	47
3.3	Flash Memory	49
3.3.1	Flash Bank Sectorization	50
3.3.2	Parallel Read Access of P-Flash	51
3.3.3	Flash Programming Width	52
3.4	Interrupt System	53
3.4.1	Interrupt Source	53
3.4.2	Interrupt Source and Vector	59
3.4.3	Interrupt Priority	61
3.5	Parallel Ports	62

Table of Contents

3.6	Power Supply System with Embedded Voltage Regulator	65
3.7	Reset Control	66
3.7.1	Module Reset Behavior	68
3.7.2	Bootling Scheme	68
3.8	Clock Generation Unit	69
3.8.1	Recommended External Oscillator Circuits	72
3.8.2	Clock Management	74
3.9	Power Saving Modes	76
3.10	Watchdog Timer	77
3.11	Multiplication/Division Unit	80
3.12	CORDIC Coprocessor	81
3.13	UART and UART1	82
3.13.1	Baud-Rate Generator	82
3.13.2	Baud Rate Generation using Timer 1	85
3.14	Normal Divider Mode (8-bit Auto-reload Timer)	85
3.15	LIN Protocol	86
3.15.1	LIN Header Transmission	87
3.16	High-Speed Synchronous Serial Interface	88
3.17	Timer 0 and Timer 1	90
3.18	Timer 2 and Timer 21	91
3.19	Capture/Compare Unit 6	92
3.20	Controller Area Network (MultiCAN)	94
3.21	Analog-to-Digital Converter	96
3.21.1	ADC Clocking Scheme	96
3.21.2	ADC Conversion Sequence	98
3.22	On-Chip Debug Support	99
3.22.1	JTAG ID Register	100
3.23	Chip Identification Number	101
4	Electrical Parameters	102
4.1	General Parameters	102
4.1.1	Parameter Interpretation	102
4.1.2	Absolute Maximum Rating	103
4.1.3	Operating Conditions	104
4.2	DC Parameters	105
4.2.1	Input/Output Characteristics	105
4.2.2	Supply Threshold Characteristics	108
4.2.3	ADC Characteristics	109
4.2.3.1	ADC Conversion Timing	112
4.2.4	Power Supply Current	113
4.3	AC Parameters	115
4.3.1	Testing Waveforms	115
4.3.2	Output Rise/Fall Times	116

Table of Contents

4.3.3	Power-on Reset and PLL Timing	117
4.3.4	On-Chip Oscillator Characteristics	119
4.3.5	External Clock Drive XTAL1	120
4.3.6	JTAG Timing	121
4.3.7	SSC Master Mode Timing	123
5	Package and Quality Declaration	124
5.1	Package Parameters	124
5.2	Package Outline	125
5.3	Quality Declaration	126

1 Summary of Features

The SAA-XC886 has the following features:

- High-performance XC800 Core
 - compatible with standard 8051 processor
 - two clocks per machine cycle architecture (for memory access without wait state)
 - two data pointers
- On-chip memory
 - 12 Kbytes of Boot ROM
 - 256 bytes of RAM
 - 1.5 Kbytes of XRAM
 - 24/32 Kbytes of Flash
(includes memory protection strategy)
- I/O port supply at 5.0 V and core logic supply at 2.5 V (generated by embedded voltage regulator)

(more features on next page)

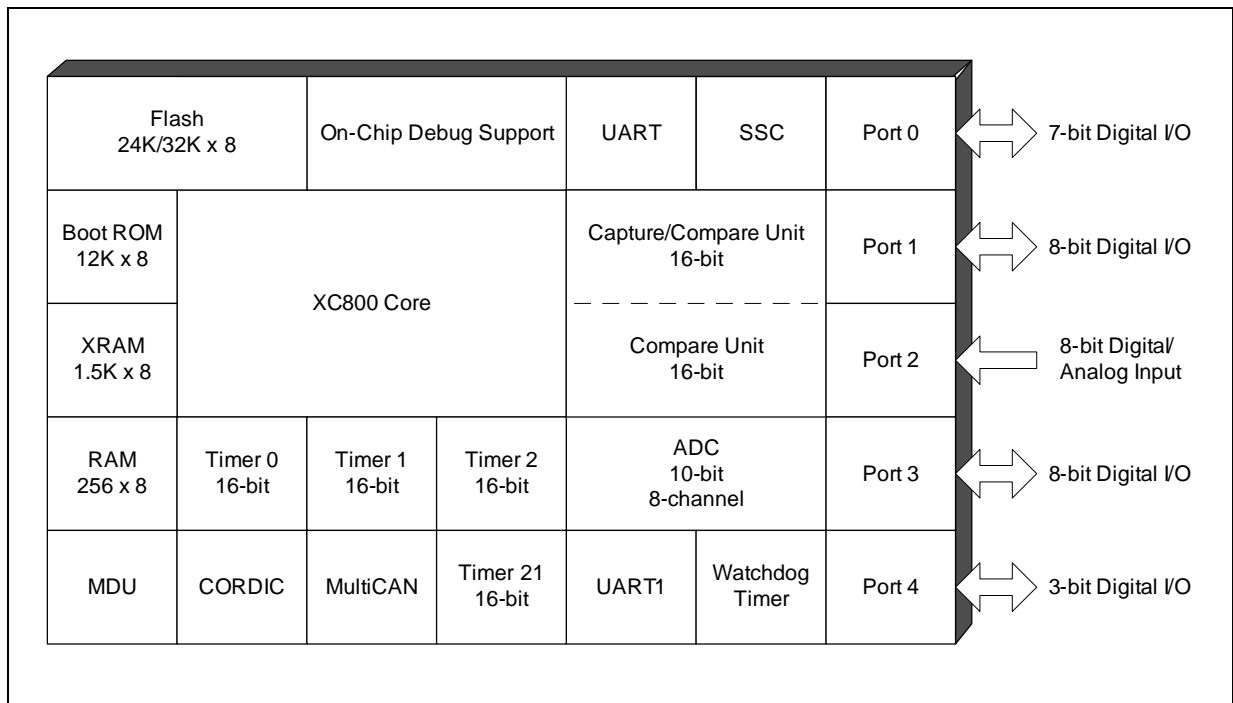

Figure 1 SAA-XC886 Functional Units

Summary of Features

Features: (continued)

- Power-on reset generation
- Brownout detection for core logic supply
- On-chip OSC and PLL for clock generation
 - PLL loss-of-lock detection
- Power saving modes
 - slow-down mode
 - idle mode
 - power-down mode with wake-up capability via RXD or EXINT0
 - clock gating control to each peripheral
- Programmable 16-bit Watchdog Timer (WDT)
- Six ports
 - Up to 48 pins as digital I/O
 - 8 pins as digital/analog input
- 8-channel, 10-bit ADC
- Four 16-bit timers
 - Timer 0 and Timer 1 (T0 and T1)
 - Timer 2 and Timer 21 (T2 and T21)
- Multiplication/Division Unit for arithmetic operations (MDU)
- Software libraries to support floating point and MDU calculations
- CORDIC Coprocessor for computation of trigonometric, hyperbolic and linear functions
- MultiCAN with 2 nodes, 32 message objects
- Capture/compare unit for PWM signal generation (CCU6)
- Two full-duplex serial interfaces (UART and UART1)
- Synchronous serial channel (SSC)
- On-chip debug support
 - 1 Kbyte of monitor ROM (part of the 12-Kbyte Boot ROM)
 - 64 bytes of monitor RAM
- Package:
 - PG-TQFP-48
- Temperature range T_A :
 - SAA (-40 to 140 °C)

Summary of Features
SAA-XC886 Variant Devices

The SAA-XC886 product family features devices with different configurations and program memory sizes, to offer cost-effective solutions for different application requirements.

The list of SAA-XC886 device configurations are summarized in [Table 1](#).

Table 1 Device Profile

Device Type	Sales Type	Program Memory (Kbytes)	CAN Module	LIN BSL Support	MDU Module
Flash	SAA-XC886-8FFA 5V	32	No	No	No
	SAA-XC886C-8FFA 5V	32	Yes	No	No
	SAA-XC886CM-8FFA 5V	32	Yes	No	Yes
	SAA-XC886LM-8FFA 5V	32	No	Yes	Yes
	SAA-XC886CLM-8FFA 5V	32	Yes	Yes	Yes
	SAA-XC886-6FFA 5V	24	No	No	No
	SAA-XC886C-6FFA 5V	24	Yes	No	No
	SAA-XC886CM-6FFA 5V	24	Yes	No	Yes
	SAA-XC886LM-6FFA 5V	24	No	Yes	Yes
	SAA-XC886CLM-6FFA 5V	24	Yes	Yes	Yes

Note: For variants with LIN BSL support, only LIN BSL is available regardless of the availability of the CAN module.

As this document refers to all the derivatives, some description may not apply to a specific product. For simplicity, all versions are referred to by the term SAA-XC886 throughout this document.

Ordering Information

The ordering code for Infineon Technologies microcontrollers provides an exact reference to the required product. This ordering code identifies:

- The derivative itself, i.e. its function set, the temperature range, and the supply voltage
- The package and the type of delivery

For the available ordering codes for the SAA-XC886, please refer to your responsible sales representative or your local distributor.

2 General Device Information

Chapter 2 contains the block diagram, pin configurations, definitions and functions of the SAA-XC886.

2.1 Block Diagram

The block diagram of the SAA-XC886 is shown in **Figure 2**.

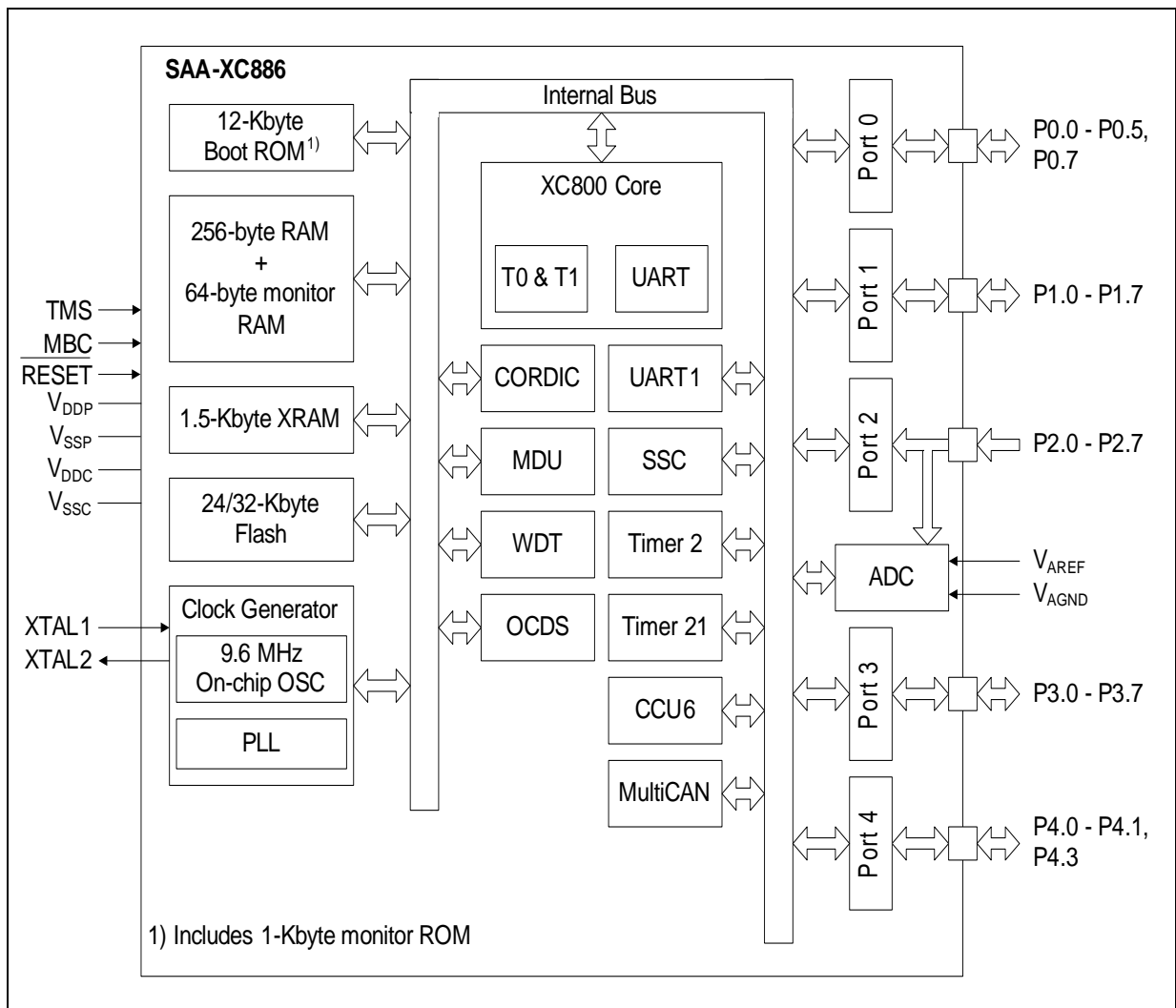

Figure 2 SAA-XC886 Block Diagram

2.2 Logic Symbol

The logic symbols of the SAA-XC886 are shown in [Figure 3](#).

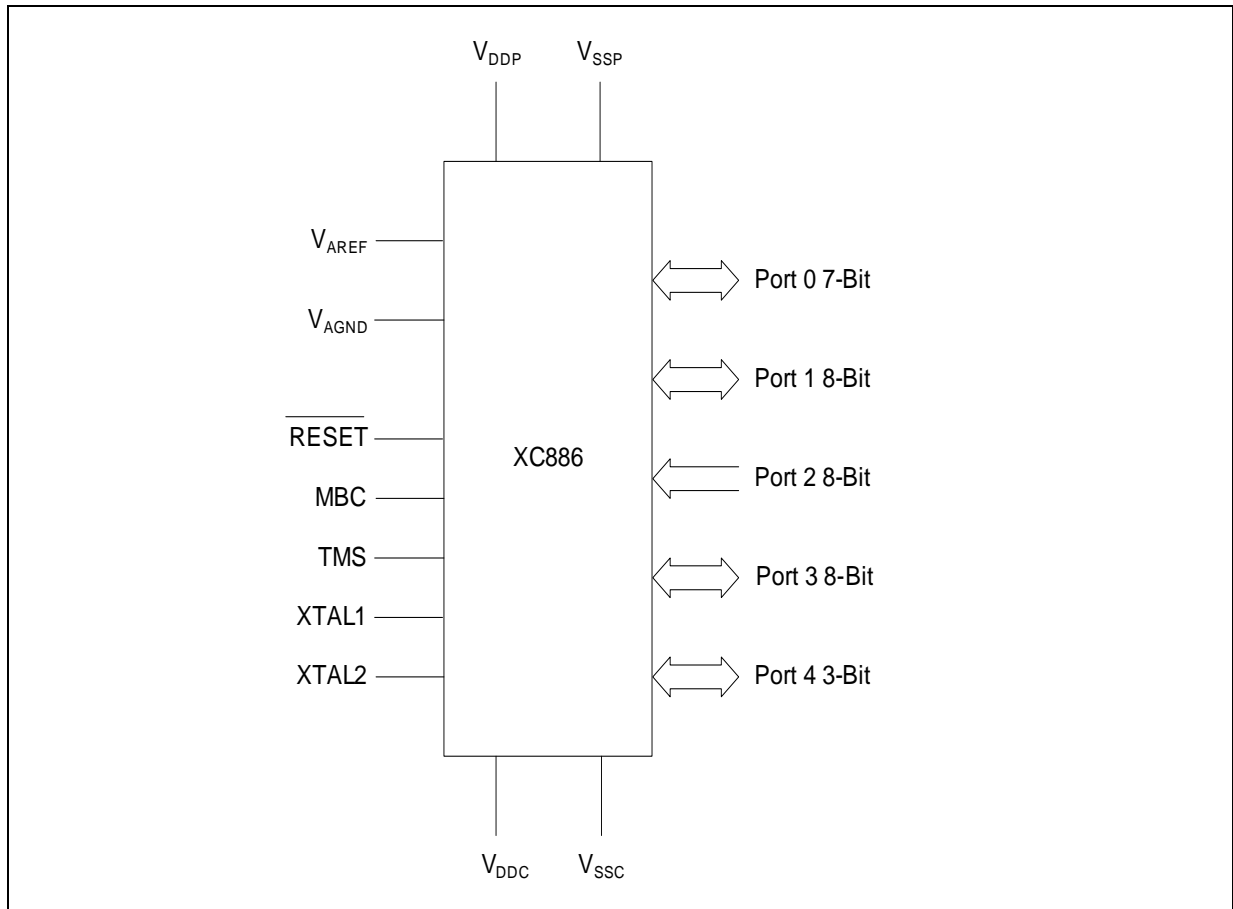

Figure 3 SAA-XC886 Logic Symbol

General Device Information

2.3 Pin Configuration

The pin configuration of the XC886, which is based on the PG-TQFP-48 package, is shown in **Figure 4**.

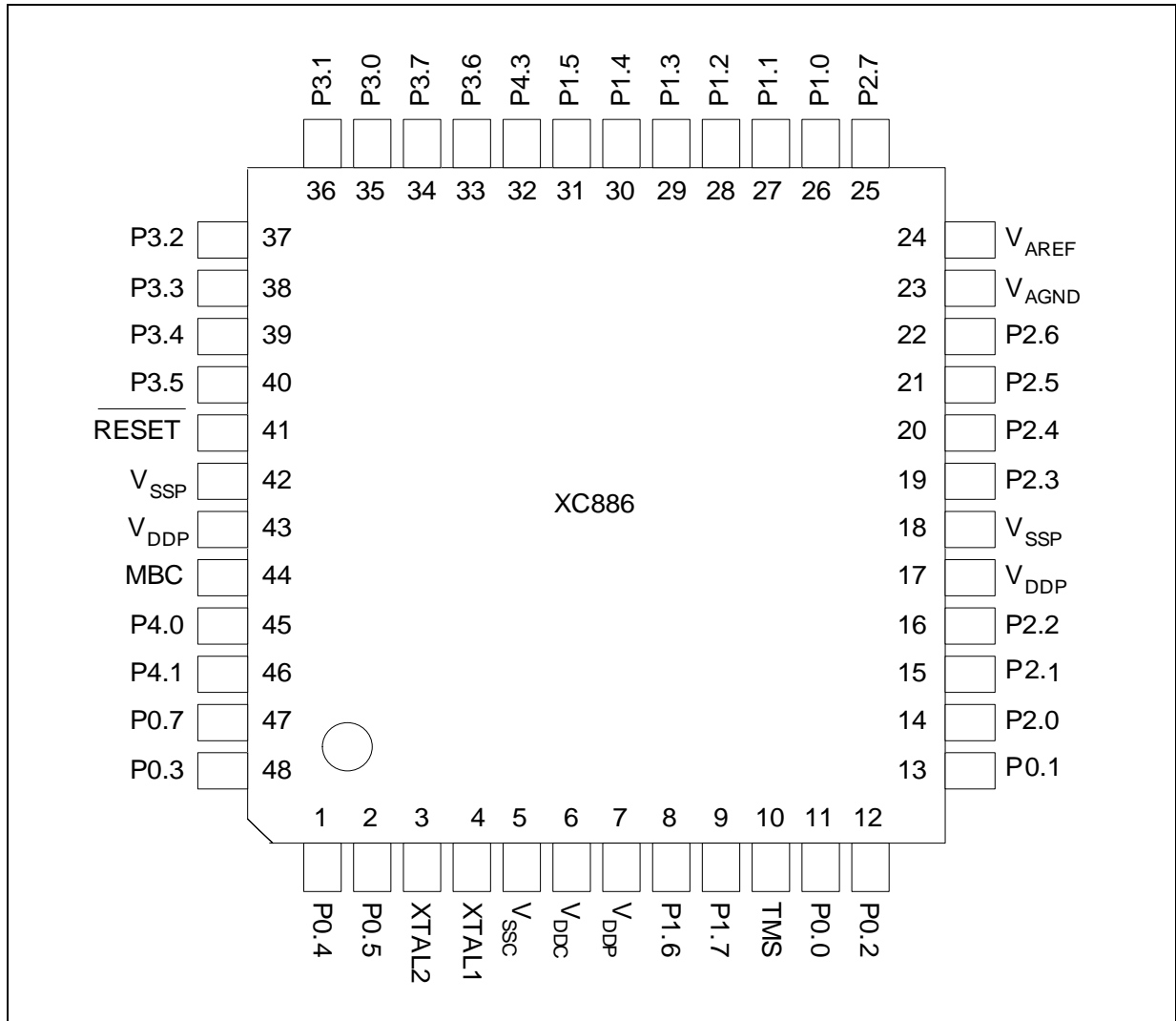

Figure 4 XC886 Pin Configuration, PG-TQFP-48 Package (top view)

2.4 Pin Definitions and Functions

The functions and default states of the SAA-XC886 external pins are provided in [Table 2](#).

Table 2 Pin Definitions and Functions

Symbol	Pin Number	Type	Reset State	Function
P0		I/O		Port 0 Port 0 is an 8-bit bidirectional general purpose I/O port. It can be used as alternate functions for the JTAG, CCU6, UART, UART1, Timer 2, Timer 21, MultiCAN and SSC.
P0.0	11		Hi-Z	TCK_0 JTAG Clock Input T12HR_1 CCU6 Timer 12 Hardware Run Input CC61_1 Input/Output of Capture/Compare channel 1 CLKOUT_0 Clock Output RXDO_1 UART Transmit Data Output
P0.1	13		Hi-Z	TDI_0 JTAG Serial Data Input T13HR_1 CCU6 Timer 13 Hardware Run Input RXD_1 UART Receive Data Input RXDC1_0 MultiCAN Node 1 Receiver Input COUT61_1 Output of Capture/Compare channel 1 EXF2_1 Timer 2 External Flag Output
P0.2	12		PU	CTR \overline AP_2 CCU6 Trap Input TDO_0 JTAG Serial Data Output TXD_1 UART Transmit Data Output/Clock Output TXDC1_0 MultiCAN Node 1 Transmitter Output
P0.3	48		Hi-Z	SCK_1 SSC Clock Input/Output COUT63_1 Output of Capture/Compare channel 3 RXDO1_0 UART1 Transmit Data Output

General Device Information
Table 2 Pin Definitions and Functions (cont'd)

Symbol	Pin Number	Type	Reset State	Function
P0.4	1		Hi-Z	MTSR_1 SSC Master Transmit Output/ Slave Receive Input CC62_1 Input/Output of Capture/Compare channel 2 TXD1_0 UART1 Transmit Data Output/Clock Output
P0.5	2		Hi-Z	MRST_1 SSC Master Receive Input/Slave Transmit Output EXINT0_0 External Interrupt Input 0 T2EX1_1 Timer 21 External Trigger Input RXD1_0 UART1 Receive Data Input COUT62_1 Output of Capture/Compare channel 2
P0.7	47		PU	CLKOUT_1 Clock Output

General Device Information
Table 2 Pin Definitions and Functions (cont'd)

Symbol	Pin Number	Type	Reset State	Function
P1		I/O		Port 1 Port 1 is an 8-bit bidirectional general purpose I/O port. It can be used as alternate functions for the JTAG, CCU6, UART, Timer 0, Timer 1, Timer 2, Timer 21, MultiCAN and SSC.
P1.0	26		PU	RXD_0 UART Receive Data Input T2EX Timer 2 External Trigger Input RXDC0_0 MultiCAN Node 0 Receiver Input
P1.1	27		PU	EXINT3 External Interrupt Input 3 T0_1 Timer 0 Input TDO_1 JTAG Serial Data Output TXD_0 UART Transmit Data Output/Clock Output TXDC0_0 MultiCAN Node 0 Transmitter Output
P1.2	28		PU	SCK_0 SSC Clock Input/Output
P1.3	29		PU	MTSR_0 SSC Master Transmit Output/Slave Receive Input TXDC1_3 MultiCAN Node 1 Transmitter Output
P1.4	30		PU	MRST_0 SSC Master Receive Input/ Slave Transmit Output EXINT0_1 External Interrupt Input 0 RXDC1_3 MultiCAN Node 1 Receiver Input
P1.5	31		PU	CCPOS0_1 CCU6 Hall Input 0 EXINT5 External Interrupt Input 5 T1_1 Timer 1 Input EXF2_0 Timer 2 External Flag Output RXDO_0 UART Transmit Data Output

General Device Information
Table 2 Pin Definitions and Functions (cont'd)

Symbol	Pin Number	Type	Reset State	Function
P1.6	8		PU	CCPOS1_1 CCU6 Hall Input 1 T12HR_0 CCU6 Timer 12 Hardware Run Input EXINT6_0 External Interrupt Input 6 RXDC0_2 MultiCAN Node 0 Receiver Input T21_1 Timer 21 Input
P1.7	9		PU	CCPOS2_1 CCU6 Hall Input 2 T13HR_0 CCU6 Timer 13 Hardware Run Input T2_1 Timer 2 Input TXDC0_2 MultiCAN Node 0 Transmitter Output P1.5 and P1.6 can be used as a software chip select output for the SSC.

General Device Information
Table 2 Pin Definitions and Functions (cont'd)

Symbol	Pin Number	Type	Reset State	Function
P2		I		Port 2 Port 2 is an 8-bit general purpose input-only port. It can be used as alternate functions for the digital inputs of the JTAG and CCU6. It is also used as the analog inputs for the ADC.
P2.0	14		Hi-Z	CCPOS0_0 CCU6 Hall Input 0 EXINT1_0 External Interrupt Input 1 T12HR_2 CCU6 Timer 12 Hardware Run Input TCK_1 JTAG Clock Input CC61_3 Input of Capture/Compare channel 1 AN0 Analog Input 0
P2.1	15		Hi-Z	CCPOS1_0 CCU6 Hall Input 1 EXINT2_0 External Interrupt Input 2 T13HR_2 CCU6 Timer 13 Hardware Run Input TDI_1 JTAG Serial Data Input CC62_3 Input of Capture/Compare channel 2 AN1 Analog Input 1
P2.2	16		Hi-Z	CCPOS2_0 CCU6 Hall Input 2 CTRAP_1 CCU6 Trap Input CC60_3 Input of Capture/Compare channel 0 AN2 Analog Input 2
P2.3	19		Hi-Z	AN3 Analog Input 3
P2.4	20		Hi-Z	AN4 Analog Input 4
P2.5	21		Hi-Z	AN5 Analog Input 5
P2.6	22		Hi-Z	AN6 Analog Input 6
P2.7	25		Hi-Z	AN7 Analog Input 7

General Device Information
Table 2 Pin Definitions and Functions (cont'd)

Symbol	Pin Number	Type	Reset State	Function
P3		I/O		Port 3 Port 3 is an 8-bit bidirectional general purpose I/O port. It can be used as alternate functions for CCU6, UART1, Timer 21 and MultiCAN.
P3.0	35		Hi-Z	CCPOS1_2 CCU6 Hall Input 1 CC60_0 Input/Output of Capture/Compare channel 0 RXD01_1 UART1 Transmit Data Output
P3.1	36		Hi-Z	CCPOS0_2 CCU6 Hall Input 0 CC61_2 Input/Output of Capture/Compare channel 1 COUT60_0 Output of Capture/Compare channel 0 TXD1_1 UART1 Transmit Data Output/Clock Output
P3.2	37		Hi-Z	CCPOS2_2 CCU6 Hall Input 2 RXDC1_1 MultiCAN Node 1 Receiver Input RXD1_1 UART1 Receive Data Input CC61_0 Input/Output of Capture/Compare channel 1
P3.3	38		Hi-Z	COUT61_0 Output of Capture/Compare channel 1 TXDC1_1 MultiCAN Node 1 Transmitter Output
P3.4	39		Hi-Z	CC62_0 Input/Output of Capture/Compare channel 2 RXDC0_1 MultiCAN Node 0 Receiver Input T2EX1_0 Timer 21 External Trigger Input
P3.5	40		Hi-Z	COUT62_0 Output of Capture/Compare channel 2 EXF21_0 Timer 21 External Flag Output TXDC0_1 MultiCAN Node 0 Transmitter Output
P3.6	33		PD	CTRAP_0 CCU6 Trap Input

General Device Information**Table 2 Pin Definitions and Functions (cont'd)**

Symbol	Pin Number	Type	Reset State	Function
P3.7	34		Hi-Z	EXINT4 External Interrupt Input 4 COUT63_0 Output of Capture/Compare channel 3

General Device Information

Table 2 Pin Definitions and Functions (cont'd)

Symbol	Pin Number	Type	Reset State	Function
P4		I/O		Port 4 Port 4 is an 8-bit bidirectional general purpose I/O port. It can be used as alternate functions for CCU6, Timer 0, Timer 1, Timer 21 and MultiCAN.
P4.0	45		Hi-Z	RXDC0_3 MultiCAN Node 0 Receiver Input CC60_1 Output of Capture/Compare channel 0
P4.1	46		Hi-Z	TXDC0_3 MultiCAN Node 0 Transmitter Output COUT60_1 Output of Capture/Compare channel 0
P4.3	32		Hi-Z	EXF21_1 Timer 21 External Flag Output COUT63_2 Output of Capture/Compare channel 3

General Device Information
Table 2 Pin Definitions and Functions (cont'd)

Symbol	Pin Number	Type	Reset State	Function
V_{DDP}	7, 17, 43	–	–	I/O Port Supply (5.0 V) Also used by EVR and analog modules. All pins must be connected.
V_{SSP}	18, 42	–	–	I/O Port Ground All pins must be connected.
V_{DDC}	6	–	–	Core Supply Monitor (2.5 V)
V_{SSC}	5	–	–	Core Supply Ground
V_{AREF}	24	–	–	ADC Reference Voltage
V_{AGND}	23	–	–	ADC Reference Ground
XTAL1	4	I	Hi-Z	External Oscillator Input (backup for on-chip OSC, normally NC)
XTAL2	3	O	Hi-Z	External Oscillator Output (backup for on-chip OSC, normally NC)
TMS	10	I	PD	Test Mode Select
RESET	41	I	PU	Reset Input
MBC¹⁾	44	I	PU	Monitor & BootStrap Loader Control

1) An external pull-up device in the range of 4.7 k Ω to 100 k Ω . is required to enter user mode. Alternatively MBC can be tied to high if alternate functions (for debugging) of the pin are not utilized.

3 Functional Description

Chapter 3 provides an overview of the SAA-XC886 functional description.

3.1 Processor Architecture

The SAA-XC886 is based on a high-performance 8-bit Central Processing Unit (CPU) that is compatible with the standard 8051 processor. While the standard 8051 processor is designed around a 12-clock machine cycle, the SAA-XC886 CPU uses a 2-clock machine cycle. This allows fast access to ROM or RAM memories without wait state. Access to the Flash memory, however, requires an additional wait state (one machine cycle). The instruction set consists of 45% one-byte, 41% two-byte and 14% three-byte instructions.

The SAA-XC886 CPU provides a range of debugging features, including basic stop/start, single-step execution, breakpoint support and read/write access to the data memory, program memory and Special Function Registers (SFRs).

Figure 5 shows the CPU functional blocks.

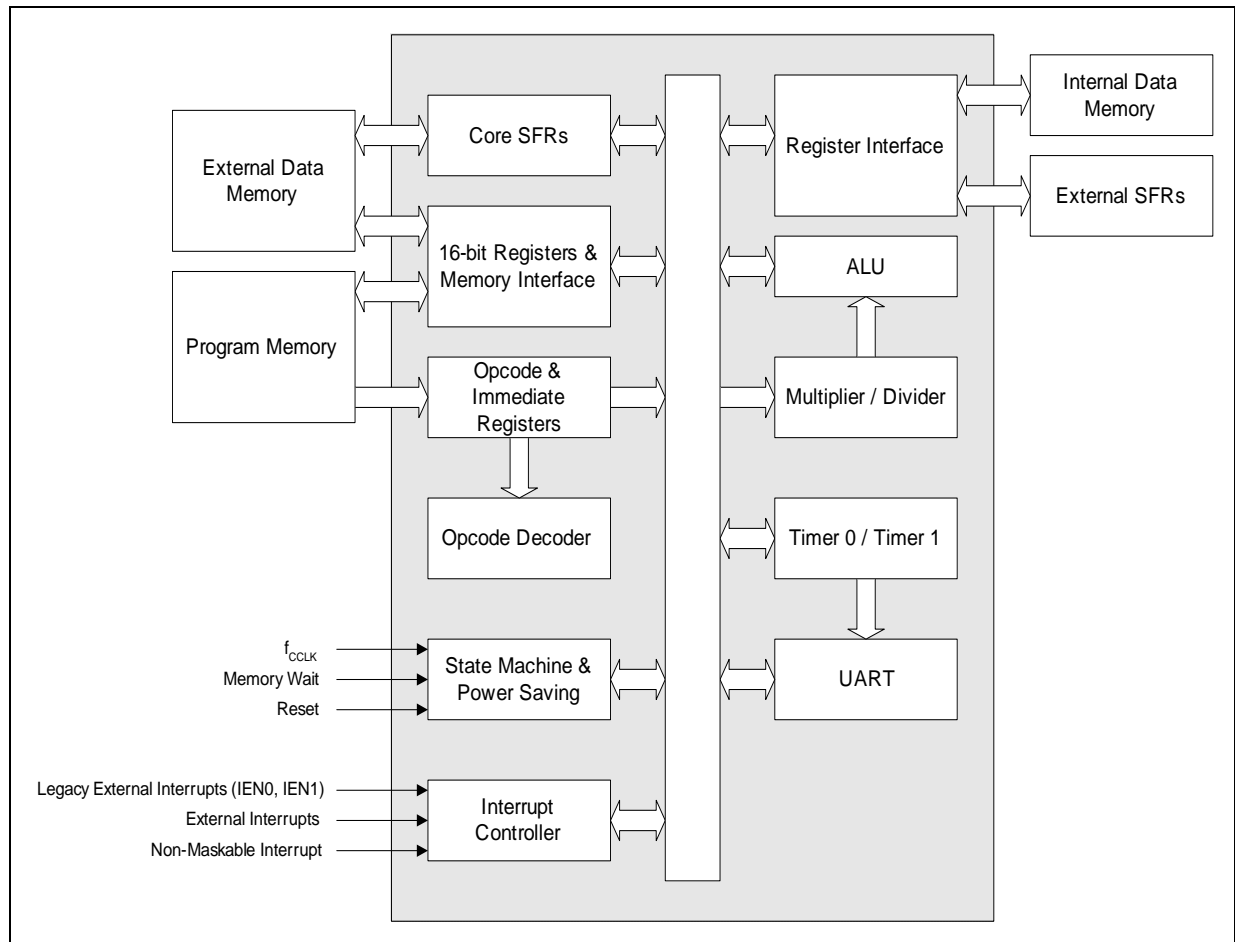

Figure 5 CPU Block Diagram

3.2 Memory Organization

The SAA-XC886 CPU operates in the following five address spaces:

- 12 Kbytes of Boot ROM program memory
- 256 bytes of internal RAM data memory
- 1.5 Kbytes of XRAM memory
(XRAM can be read/written as program memory or external data memory)
- A 128-byte Special Function Register area
- 24/32 Kbytes of Flash program memory

Figure 6 illustrates the memory address spaces of the 32-Kbyte Flash devices. For the 24-Kbyte Flash devices, the shaded banks are not available.

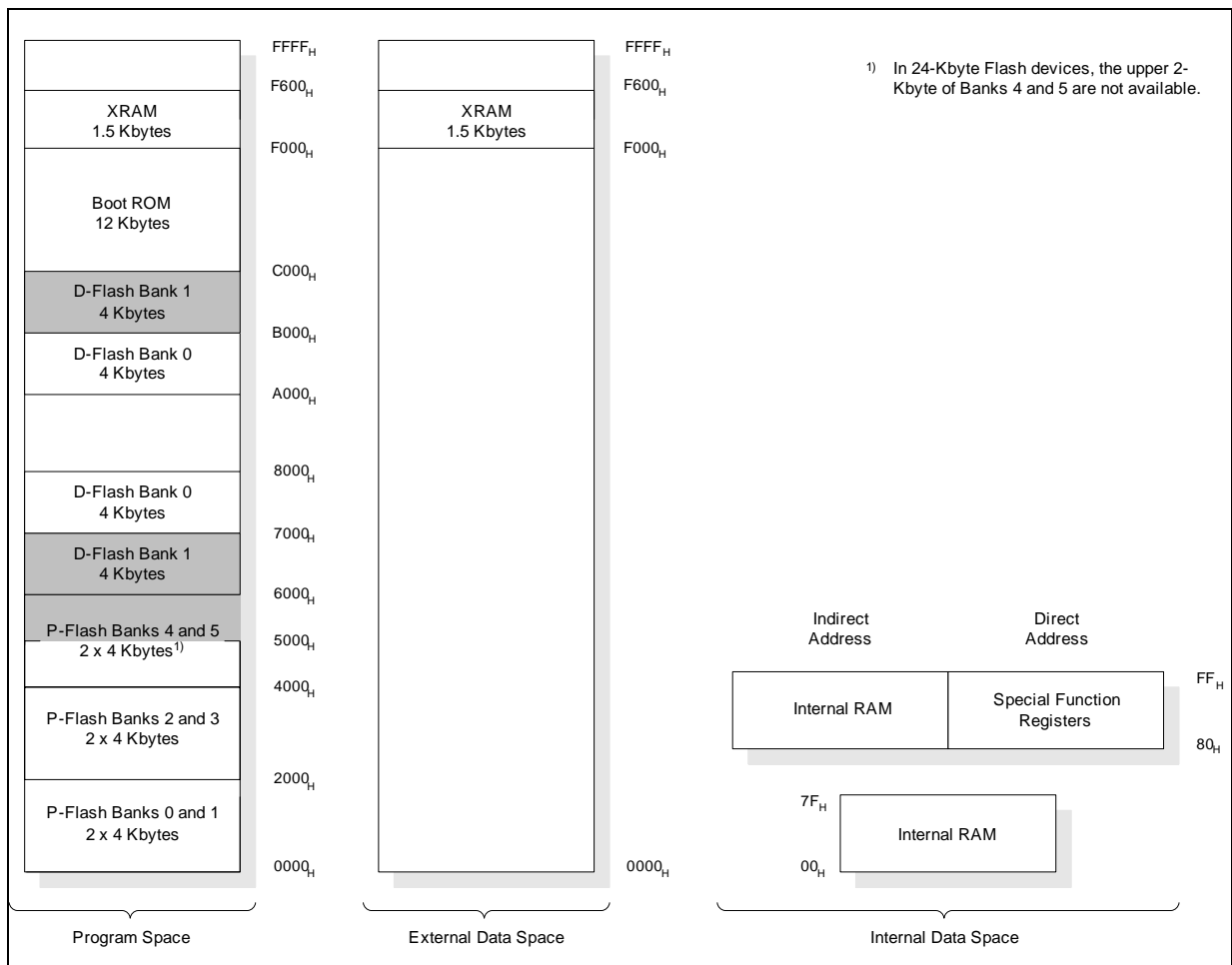

Figure 6 Memory Map of SAA-XC886 Flash Device

3.2.1 Memory Protection Strategy

The SAA-XC886 memory protection strategy includes:

- Read-out protection: The user is able to protect the contents in the Flash memory from being read
 - Flash protection is enabled by programming a valid password (8-bit non-zero value) via BSL mode 6.
- Flash program and erase protection.

3.2.1.1 Flash Memory Protection

As long as a valid password is available, all external access to the device, including the Flash, will be blocked.

For additional security, the Flash hardware protection can be enabled to implement a second layer of read-out protection, as well as to enable program and erase protection. Flash hardware protection is available only for Flash devices and comes in two modes:

- Mode 0: Only the P-Flash is protected; the D-Flash is unprotected
- Mode 1: Both the P-Flash and D-Flash are protected

The selection of each protection mode and the restrictions imposed are summarized in [Table 3](#).

Table 3 Flash Protection Modes

Flash Protection	Without hardware protection		With hardware protection	
			0	1
Hardware Protection Mode	-		0	1
Activation	Program a valid password via BSL mode 6			
Selection	Bit 4 of password = 0	Bit 4 of password = 1	MSB of password = 0	MSB of password = 1
P-Flash contents can be read by	Read instructions in any program memory	Read instructions in the P-Flash	Read instructions in the P-Flash or D-Flash	
External access to P-Flash	Not possible	Not possible	Not possible	
P-Flash program and erase	Possible	Not possible	Not possible	
D-Flash contents can be read by	Read instructions in any program memory	Read instructions in any program memory	Read instructions in the P-Flash or D-Flash	

Functional Description
Table 3 Flash Protection Modes (cont'd)

Flash Protection	Without hardware protection		With hardware protection	
External access to D-Flash	Not possible		Not possible	Not possible
D-Flash program	Possible		Possible	Not possible
D-Flash erase	Possible		Possible, on condition that bit DFLASHEN in register MISC_CON is set to 1 prior to each erase operation	Not possible

BSL mode 6, which is used for enabling Flash protection, can also be used for disabling Flash protection. Here, the programmed password must be provided by the user. A password match triggers an automatic erase of the protected P-Flash and D-Flash contents, including the programmed password. The Flash protection is then disabled upon the next reset.

Although no protection scheme can be considered infallible, the SAA-XC886 memory protection strategy provides a very high level of protection for a general purpose microcontroller.

3.2.2 Special Function Register

The Special Function Registers (SFRs) occupy direct internal data memory space in the range 80_{H} to FF_{H} . All registers, except the program counter, reside in the SFR area. The SFRs include pointers and registers that provide an interface between the CPU and the on-chip peripherals. As the 128-SFR range is less than the total number of registers required, address extension mechanisms are required to increase the number of addressable SFRs. The address extension mechanisms include:

- Mapping
- Paging

3.2.2.1 Address Extension by Mapping

Address extension is performed at the system level by mapping. The SFR area is extended into two portions: the standard (non-mapped) SFR area and the mapped SFR area. Each portion supports the same address range 80_{H} to FF_{H} , bringing the number of addressable SFRs to 256. The extended address range is not directly controlled by the CPU instruction itself, but is derived from bit RMAP in the system control register SYSCON0 at address 8F_{H} . To access SFRs in the mapped area, bit RMAP in SFR SYSCON0 must be set. Alternatively, the SFRs in the standard area can be accessed by clearing bit RMAP. The SFR area can be selected as shown in [Figure 7](#).

As long as bit RMAP is set, the mapped SFR area can be accessed. This bit is not cleared automatically by hardware. Thus, before standard/mapped registers are accessed, bit RMAP must be cleared/set, respectively, by software.

Functional Description

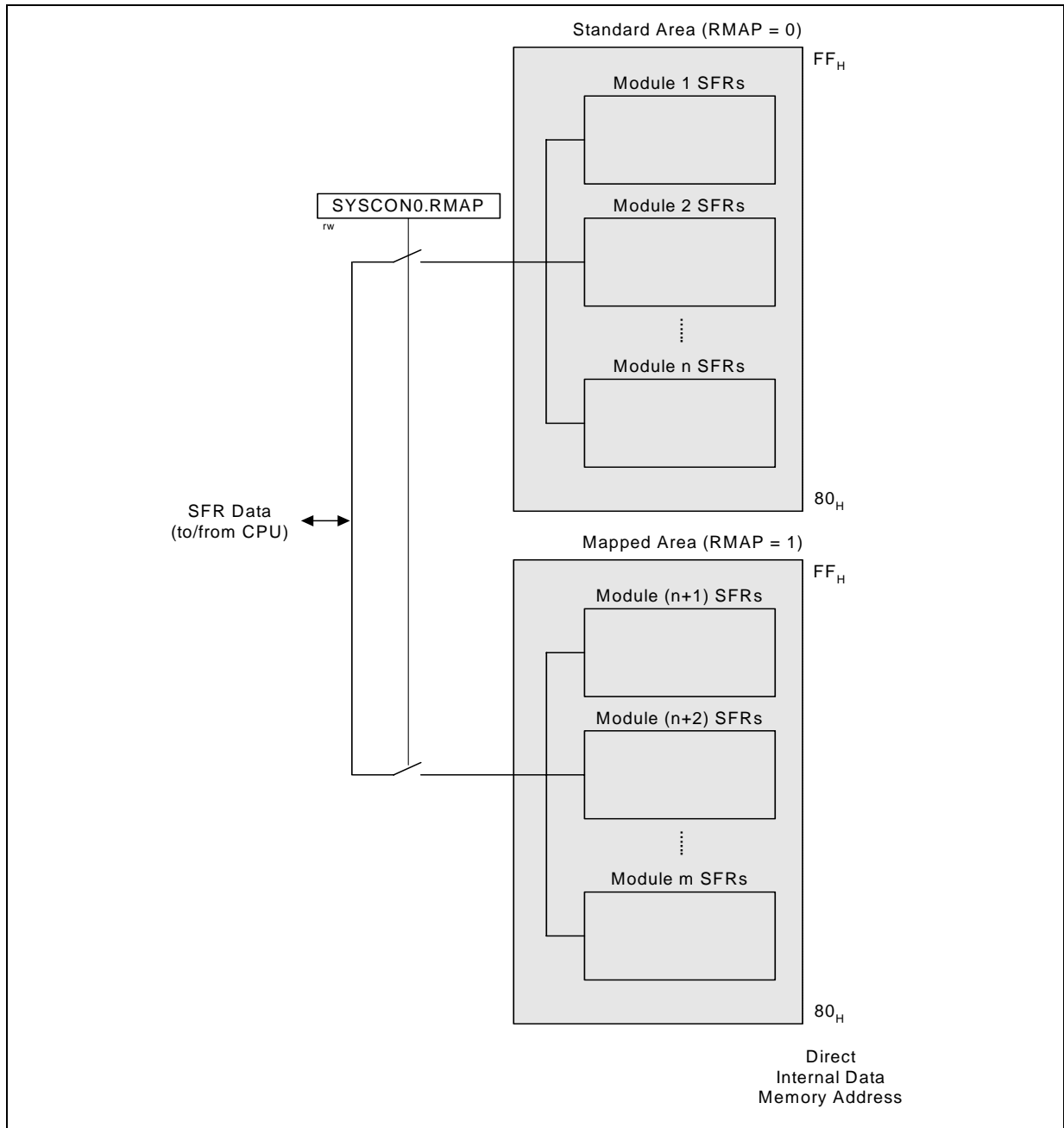

Figure 7 Address Extension by Mapping

Functional Description

SYSCON0

System Control Register 0

Reset Value: 04_H

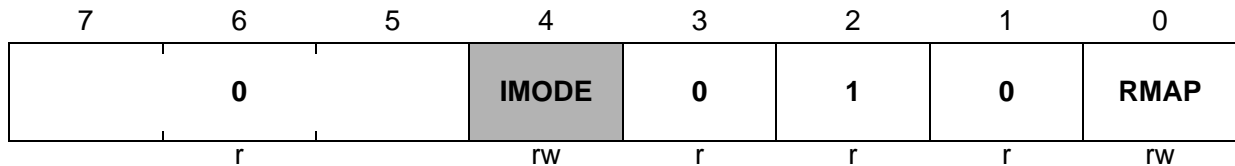

Field	Bits	Type	Description
RMAP	0	rw	Interrupt Node XINTR0 Enable 0 The access to the standard SFR area is enabled 1 The access to the mapped SFR area is enabled
1	2	r	Reserved Returns 1 if read; should be written with 1.
0	[7:5], 3,1	r	Reserved Returns 0 if read; should be written with 0.

Note: The RMAP bit should be cleared/set by ANL or ORL instructions.

3.2.2.2 Address Extension by Paging

Address extension is further performed at the module level by paging. With the address extension by mapping, the SAA-XC886 has a 256-SFR address range. However, this is still less than the total number of SFRs needed by the on-chip peripherals. To meet this requirement, some peripherals have a built-in local address extension mechanism for increasing the number of addressable SFRs. The extended address range is not directly controlled by the CPU instruction itself, but is derived from bit field PAGE in the module page register MOD_PAGE. Hence, the bit field PAGE must be programmed before accessing the SFR of the target module. Each module may contain a different number of pages and a different number of SFRs per page, depending on the specific requirement. Besides setting the correct RMAP bit value to select the SFR area, the user must also ensure that a valid PAGE is selected to target the desired SFR. A page inside the extended address range can be selected as shown in [Figure 8](#).

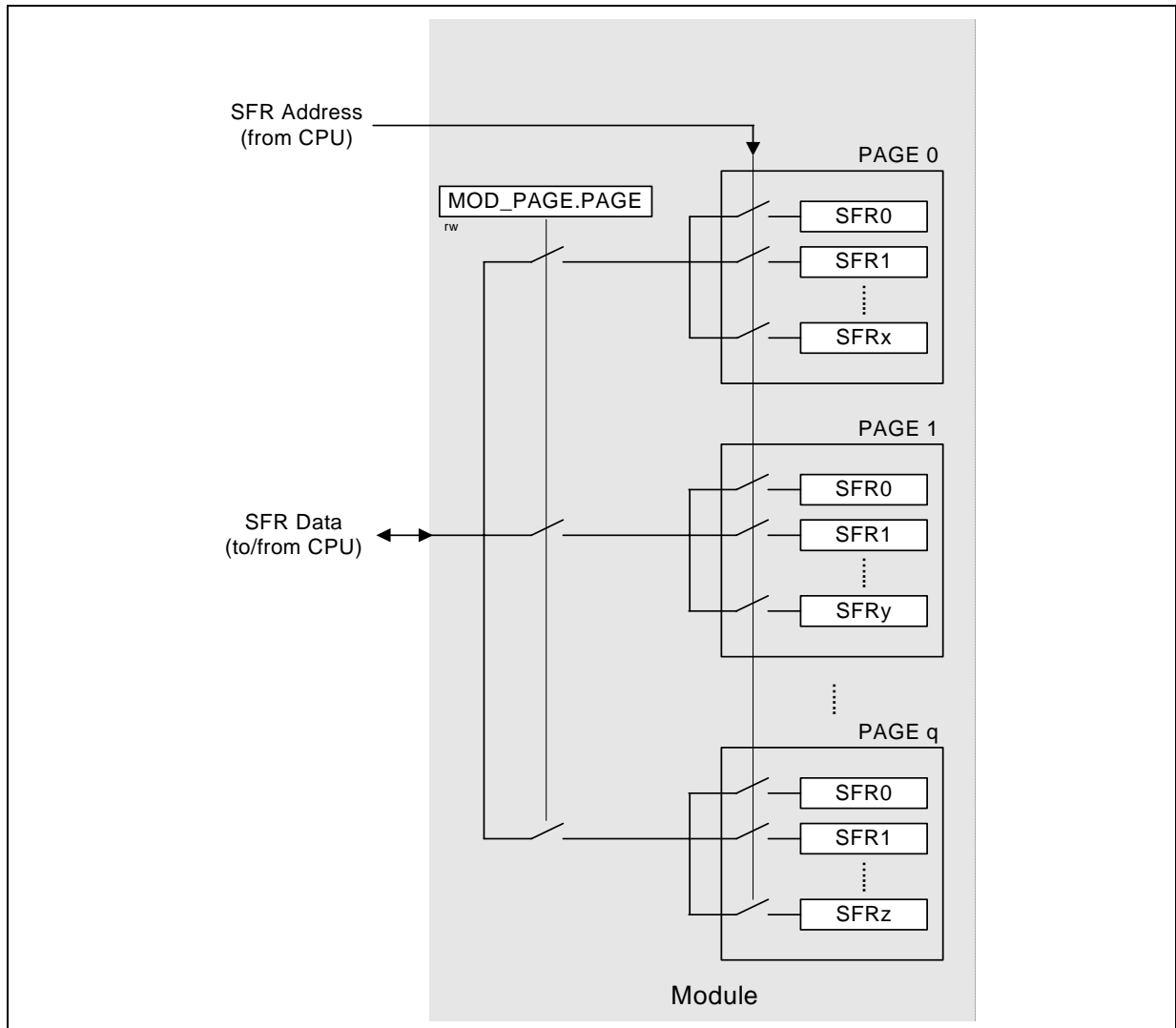

Figure 8 Address Extension by Paging

In order to access a register located in a page different from the actual one, the current page must be exited. This is done by reprogramming the bit field PAGE in the page register. Only then can the desired access be performed.

If an interrupt routine is initiated between the page register access and the module register access, and the interrupt needs to access a register located in another page, the current page setting can be saved, the new one programmed and the old page setting restored. This is possible with the storage fields STx (x = 0 - 3) for the save and restore action of the current page setting. By indicating which storage bit field should be used in parallel with the new page value, a single write operation can:

- Save the contents of PAGE in STx before overwriting with the new value (this is done in the beginning of the interrupt routine to save the current page setting and program the new page number); or

Functional Description

- Overwrite the contents of PAGE with the contents of STx, ignoring the value written to the bit positions of PAGE
(this is done at the end of the interrupt routine to restore the previous page setting before the interrupt occurred)

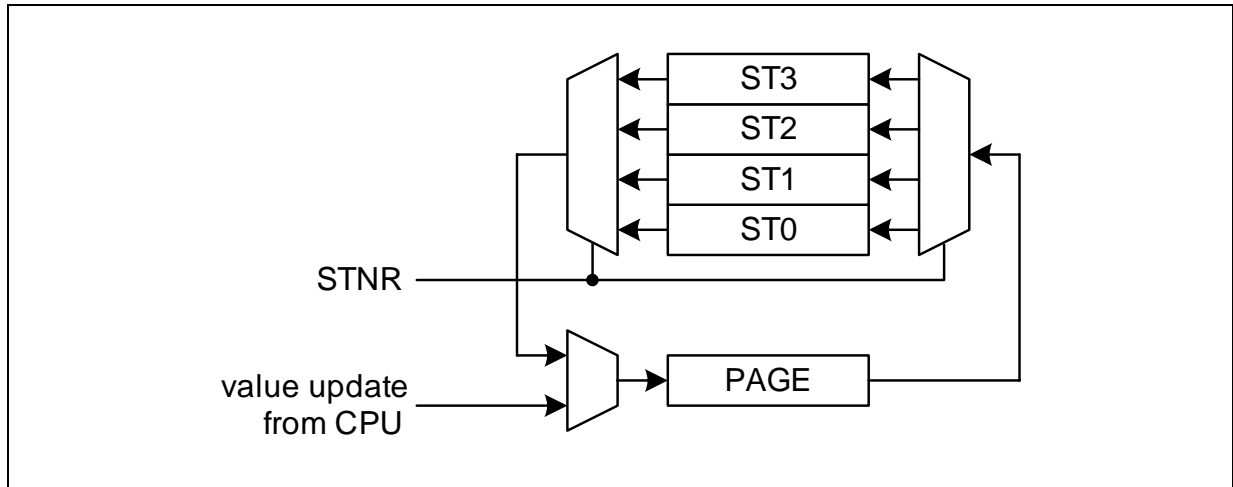

Figure 9 Storage Elements for Paging

With this mechanism, a certain number of interrupt routines (or other routines) can perform page changes without reading and storing the previously used page information. The use of only write operations makes the system simpler and faster. Consequently, this mechanism significantly improves the performance of short interrupt routines.

The SAA-XC886 supports local address extension for:

- Parallel Ports
- Analog-to-Digital Converter (ADC)
- Capture/Compare Unit 6 (CCU6)
- System Control Registers

Functional Description

The page register has the following definition:

MOD_PAGE

Page Register for module MOD

Reset Value: 00_H

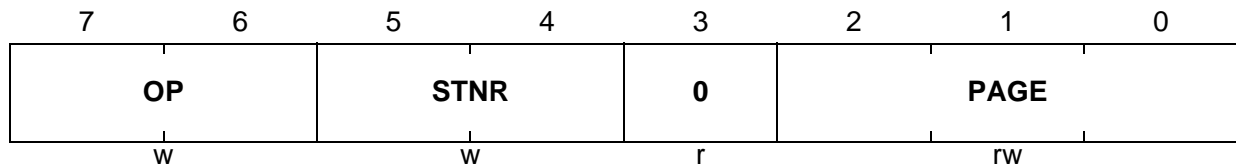

Field	Bits	Type	Description
PAGE	[2:0]	rw	<p>Page Bits</p> <p>When written, the value indicates the new page. When read, the value indicates the currently active page.</p>
STNR	[5:4]	w	<p>Storage Number</p> <p>This number indicates which storage bit field is the target of the operation defined by bit field OP. If OP = 10_B, the contents of PAGE are saved in STx before being overwritten with the new value. If OP = 11_B, the contents of PAGE are overwritten by the contents of STx. The value written to the bit positions of PAGE is ignored.</p> <p>00 ST0 is selected. 01 ST1 is selected. 10 ST2 is selected. 11 ST3 is selected.</p>

Functional Description

Field	Bits	Type	Description
OP	[7:6]	w	Operation 0X Manual page mode. The value of STNR is ignored and PAGE is directly written. 10 New page programming with automatic page saving. The value written to the bit positions of PAGE is stored. In parallel, the previous contents of PAGE are saved in the storage bit field STx indicated by STNR. 11 Automatic restore page action. The value written to the bit positions PAGE is ignored and instead, PAGE is overwritten by the contents of the storage bit field STx indicated by STNR.
0	3	r	Reserved Returns 0 if read; should be written with 0.

3.2.3 Bit Protection Scheme

The bit protection scheme prevents direct software writing of selected bits (i.e., protected bits) using the PASSWD register. When the bit field MODE is 11_B, writing 10011_B to the bit field PASS opens access to writing of all protected bits, and writing 10101_B to the bit field PASS closes access to writing of all protected bits. In both cases, the value of the bit field MODE is not changed even if PASSWD register is written with 98_H or A8_H. It can only be changed when bit field PASS is written with 11000_B, for example, writing D0_H to PASSWD register disables the bit protection scheme.

Note that access is opened for maximum 32 CCLKs if the “close access” password is not written. If “open access” password is written again before the end of 32 CCLK cycles, there will be a recount of 32 CCLK cycles. The protected bits include the N- and K-Divider bits, NDIV and KDIV; the Watchdog Timer enable bit, WDTEN; and the power-down and slow-down enable bits, PD and SD.

Functional Description

3.2.3.1 Password Register

PASSWD

Password Register

Reset Value: 07_H

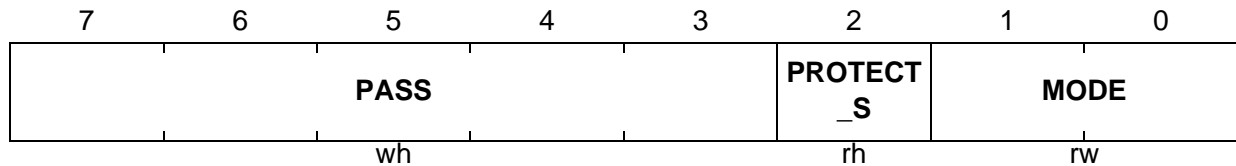

Field	Bits	Type	Description
MODE	[1:0]	rw	<p>Bit Protection Scheme Control Bits</p> <p>00 Scheme disabled - direct access to the protected bits is allowed.</p> <p>11 Scheme enabled - the bit field PASS has to be written with the passwords to open and close the access to protected bits. (default)</p> <p>Others: Scheme Enabled.</p> <p>These two bits cannot be written directly. To change the value between 11_B and 00_B, the bit field PASS must be written with 11000_B; only then, will the MODE[1:0] be registered.</p>
PROTECT_S	2	rh	<p>Bit Protection Signal Status Bit</p> <p>This bit shows the status of the protection.</p> <p>0 Software is able to write to all protected bits.</p> <p>1 Software is unable to write to any protected bits.</p>
PASS	[7:3]	wh	<p>Password Bits</p> <p>The Bit Protection Scheme only recognizes three patterns.</p> <p>11000_B Enables writing of the bit field MODE.</p> <p>10011_B Opens access to writing of all protected bits.</p> <p>10101_B Closes access to writing of all protected bits</p>

Functional Description
3.2.4 SAA-XC886 Register Overview

The SFRs of the SAA-XC886 are organized into groups according to their functional units. The contents (bits) of the SFRs are summarized in [Chapter 3.2.4.1](#) to [Chapter 3.2.4.14](#).

Note: The addresses of the bitaddressable SFRs appear in bold typeface.

3.2.4.1 CPU Registers

The CPU SFRs can be accessed in both the standard and mapped memory areas (RMAP = 0 or 1).

Table 4 CPU Register Overview

Addr	Register Name	Bit	7	6	5	4	3	2	1	0
RMAP = 0 or 1										
81 _H	SP Stack Pointer Register Reset: 07 _H	Bit Field	SP							
		Type	rw							
82 _H	DPL Data Pointer Register Low Reset: 00 _H	Bit Field	DPL7	DPL6	DPL5	DPL4	DPL3	DPL2	DPL1	DPL0
		Type	rw	rw	rw	rw	rw	rw	rw	rw
83 _H	DPH Data Pointer Register High Reset: 00 _H	Bit Field	DPH7	DPH6	DPH5	DPH4	DPH3	DPH2	DPH1	DPH0
		Type	rw	rw	rw	rw	rw	rw	rw	rw
87 _H	PCON Power Control Register Reset: 00 _H	Bit Field	SMOD	0			GF1	GF0	0	IDLE
		Type	rw	r			rw	rw	r	rw
88 _H	TCON Timer Control Register Reset: 00 _H	Bit Field	TF1	TR1	TF0	TR0	IE1	IT1	IE0	IT0
		Type	rwh	rw	rwh	rw	rwh	rw	rwh	rw
89 _H	TMOD Timer Mode Register Reset: 00 _H	Bit Field	GATE 1	T1S	T1M		GATE 0	T0S	T0M	
		Type	rw	rw	rw		rw	rw	rw	
8A _H	TL0 Timer 0 Register Low Reset: 00 _H	Bit Field	VAL							
		Type	rwh							
8B _H	TL1 Timer 1 Register Low Reset: 00 _H	Bit Field	VAL							
		Type	rwh							
8C _H	TH0 Timer 0 Register High Reset: 00 _H	Bit Field	VAL							
		Type	rwh							
8D _H	TH1 Timer 1 Register High Reset: 00 _H	Bit Field	VAL							
		Type	rwh							
98 _H	SCON Serial Channel Control Register Reset: 00 _H	Bit Field	SM0	SM1	SM2	REN	TB8	RB8	TI	RI
		Type	rw	rw	rw	rw	rw	rwh	rwh	rwh
99 _H	SBUF Serial Data Buffer Register Reset: 00 _H	Bit Field	VAL							
		Type	rwh							

Functional Description
Table 4 CPU Register Overview (cont'd)

Addr	Register Name	Bit	7	6	5	4	3	2	1	0
A2 _H	EO Extended Operation Register Reset: 00 _H	Bit Field	0			TRAP_EN	0			DPSE_L0
		Type	r			rw	r			rw
A8 _H	IEN0 Interrupt Enable Register 0 Reset: 00 _H	Bit Field	EA	0	ET2	ES	ET1	EX1	ET0	EX0
		Type	rw	r	rw	rw	rw	rw	rw	rw
B8 _H	IP Interrupt Priority Register Reset: 00 _H	Bit Field	0		PT2	PS	PT1	PX1	PT0	PX0
		Type	r		rw	rw	rw	rw	rw	rw
B9 _H	IPH Interrupt Priority High Register Reset: 00 _H	Bit Field	0		PT2H	PSH	PT1H	PX1H	PT0H	PX0H
		Type	r		rw	rw	rw	rw	rw	rw
D0 _H	PSW Program Status Word Register Reset: 00 _H	Bit Field	CY	AC	F0	RS1	RS0	OV	F1	P
		Type	rwh	rwh	rw	rw	rw	rwh	rw	rh
E0 _H	ACC Accumulator Register Reset: 00 _H	Bit Field	ACC7	ACC6	ACC5	ACC4	ACC3	ACC2	ACC1	ACC0
		Type	rw	rw	rw	rw	rw	rw	rw	rw
E8 _H	IEN1 Interrupt Enable Register 1 Reset: 00 _H	Bit Field	ECCIP 3	ECCIP 2	ECCIP 1	ECCIP 0	EXM	EX2	ESSC	EADC
		Type	rw	rw	rw	rw	rw	rw	rw	rw
F0 _H	B B Register Reset: 00 _H	Bit Field	B7	B6	B5	B4	B3	B2	B1	B0
		Type	rw	rw	rw	rw	rw	rw	rw	rw
F8 _H	IP1 Interrupt Priority 1 Register Reset: 00 _H	Bit Field	PCCIP 3	PCCIP 2	PCCIP 1	PCCIP 0	PXM	PX2	PSSC	PADC
		Type	rw	rw	rw	rw	rw	rw	rw	rw
F9 _H	IPH1 Interrupt Priority 1 High Register Reset: 00 _H	Bit Field	PCCIP 3H	PCCIP 2H	PCCIP 1H	PCCIP 0H	PXMH	PX2H	PSSC H	PADC H
		Type	rw	rw	rw	rw	rw	rw	rw	rw

3.2.4.2 MDU Registers

The MDU SFRs can be accessed in the mapped memory area (RMAP = 1).

Table 5 MDU Register Overview

Addr	Register Name	Bit	7	6	5	4	3	2	1	0
RMAP = 1										
B0 _H	MDUSTAT MDU Status Register Reset: 00 _H	Bit Field	0					BSY	IERR	IRDY
		Type	r					rh	rwh	rwh
B1 _H	MDUCON MDU Control Register Reset: 00 _H	Bit Field	IE	IR	RSEL	STAR T	OPCODE			
		Type	rw	rw	rw	rwh	rw			
B2 _H	MD0 MDU Operand Register 0 Reset: 00 _H	Bit Field	DATA							
		Type	rw							
B2 _H	MR0 MDU Result Register 0 Reset: 00 _H	Bit Field	DATA							
		Type	rh							

Functional Description
Table 5 MDU Register Overview (cont'd)

Addr	Register Name	Bit	7	6	5	4	3	2	1	0
B3 _H	MD1 Reset: 00_H MDU Operand Register 1	Bit Field	DATA							
		Type	rw							
B3 _H	MR1 Reset: 00_H MDU Result Register 1	Bit Field	DATA							
		Type	rh							
B4 _H	MD2 Reset: 00_H MDU Operand Register 2	Bit Field	DATA							
		Type	rw							
B4 _H	MR2 Reset: 00_H MDU Result Register 2	Bit Field	DATA							
		Type	rh							
B5 _H	MD3 Reset: 00_H MDU Operand Register 3	Bit Field	DATA							
		Type	rw							
B5 _H	MR3 Reset: 00_H MDU Result Register 3	Bit Field	DATA							
		Type	rh							
B6 _H	MD4 Reset: 00_H MDU Operand Register 4	Bit Field	DATA							
		Type	rw							
B6 _H	MR4 Reset: 00_H MDU Result Register 4	Bit Field	DATA							
		Type	rh							
B7 _H	MD5 Reset: 00_H MDU Operand Register 5	Bit Field	DATA							
		Type	rw							
B7 _H	MR5 Reset: 00_H MDU Result Register 5	Bit Field	DATA							
		Type	rh							

3.2.4.3 CORDIC Registers

The CORDIC SFRs can be accessed in the mapped memory area (RMAP = 1).

Table 6 CORDIC Register Overview

Addr	Register Name	Bit	7	6	5	4	3	2	1	0
RMAP = 1										
9A _H	CD_CORDXL Reset: 00_H CORDIC X Data Low Byte	Bit Field	DATA							
		Type	rw							
9B _H	CD_CORDXH Reset: 00_H CORDIC X Data High Byte	Bit Field	DATA							
		Type	rw							
9C _H	CD_CORDYL Reset: 00_H CORDIC Y Data Low Byte	Bit Field	DATA							
		Type	rw							
9D _H	CD_CORDYH Reset: 00_H CORDIC Y Data High Byte	Bit Field	DATA							
		Type	rw							
9E _H	CD_CORDZL Reset: 00_H CORDIC Z Data Low Byte	Bit Field	DATA							
		Type	rw							

Functional Description
Table 6 CORDIC Register Overview (cont'd)

Addr	Register Name	Bit	7	6	5	4	3	2	1	0
9F _H	CD_CORDZH Reset: 00 _H CORDIC Z Data High Byte	Bit Field	DATAH							
		Type	rw							
A0 _H	CD_STATC Reset: 00 _H CORDIC Status and Data Control Register	Bit Field	KEEP Z	KEEP Y	KEEP X	DMAP	INT_EN	EOC	ERROR	BSY
		Type	rw	rw	rw	rw	rw	rwh	rh	rh
A1 _H	CD_CON Reset: 00 _H CORDIC Control Register	Bit Field	MPS		X_USIGN	ST_MODE	ROTV EC	MODE		ST
		Type	rw		rw	rw	rw	rw		rwh

3.2.4.4 System Control Registers

The system control SFRs can be accessed in the mapped memory area (RMAP = 0).

Table 7 SCU Register Overview

Addr	Register Name	Bit	7	6	5	4	3	2	1	0	
RMAP = 0 or 1											
8F _H	SYSCON0 Reset: 04 _H System Control Register 0	Bit Field	0			IMODE	0	1	0	RMAP	
		Type	r			rw	r	r	r	rw	
RMAP = 0											
BF _H	SCU_PAGE Reset: 00 _H Page Register	Bit Field	OP		STNR		0	PAGE			
		Type	w		w		r	rw			
RMAP = 0, PAGE 0											
B3 _H	MODPSEL Reset: 00 _H Peripheral Input Select Register	Bit Field	0	URRISH	JTAGT DIS	JTAGT CKS	EXINT 2IS	EXINT 1IS	EXINT 0IS	URRIS	
		Type	r	rw	rw	rw	rw	rw	rw	rw	
B4 _H	IRCON0 Reset: 00 _H Interrupt Request Register 0	Bit Field	0	EXINT 6	EXINT 5	EXINT 4	EXINT 3	EXINT 2	EXINT 1	EXINT 0	
		Type	r	rwh	rwh	rwh	rwh	rwh	rwh	rwh	
B5 _H	IRCON1 Reset: 00 _H Interrupt Request Register 1	Bit Field	0	CANS RC2	CANS RC1	ADCS R1	ADCS R0	RIR	TIR	EIR	
		Type	r	rwh	rwh	rwh	rwh	rwh	rwh	rwh	
B6 _H	IRCON2 Reset: 00 _H Interrupt Request Register 2	Bit Field	0			CANS RC3	0			CANS RC0	
		Type	r			rwh	r			rwh	
B7 _H	EXICON0 Reset: F0 _H External Interrupt Control Register 0	Bit Field	EXINT3		EXINT2		EXINT1		EXINT0		
		Type	rw		rw		rw		rw		
BA _H	EXICON1 Reset: 3F _H External Interrupt Control Register 1	Bit Field	0		EXINT6		EXINT5		EXINT4		
		Type	r		rw		rw		rw		
BB _H	NMICON Reset: 00 _H NMI Control Register	Bit Field	0	NMI ECC	NMI VDDP	NMI VDD	NMI OCDS	NMI FLASH	NMI PLL	NMI WDT	
		Type	r	rw	rw	rw	rw	rw	rw	rw	

Functional Description
Table 7 SCU Register Overview (cont'd)

Addr	Register Name	Bit	7	6	5	4	3	2	1	0	
BC _H	NMISR Reset: 00 _H NMI Status Register	Bit Field	0	FNMI ECC	FNMI VDDP	FNMI VDD	FNMI OCDS	FNMI FLASH	FNMI PLL	FNMI WDT	
		Type	r	rwh	rwh	rwh	rwh	rwh	rwh	rwh	
BD _H	BCON Reset: 00 _H Baud Rate Control Register	Bit Field	BGSEL		0	BRDIS	BRPRE			R	
		Type	rw		r	rw	rw			rw	
BE _H	BG Reset: 00 _H Baud Rate Timer/Reload Register	Bit Field	BR_VALUE								
		Type	rwh								
E9 _H	FDCON Reset: 00 _H Fractional Divider Control Register	Bit Field	BGS	SYNE N	ERRS YN	EOFS YN	BRK	NDOV	FDM	FDEN	
		Type	rw	rw	rwh	rwh	rwh	rwh	rw	rw	
EA _H	FDSTEP Reset: 00 _H Fractional Divider Reload Register	Bit Field	STEP								
		Type	rw								
EB _H	FDRES Reset: 00 _H Fractional Divider Result Register	Bit Field	RESULT								
		Type	rh								
RMAP = 0, PAGE 1											
B3 _H	ID Reset: UU _H Identity Register	Bit Field	PRODID					VERID			
		Type	r					r			
B4 _H	PMCON0 Reset: 00 _H Power Mode Control Register 0	Bit Field	0	WDT RST	WKRS	WK SEL	SD	PD	WS		
		Type	r	rwh	rwh	rw	rw	rwh	rw		
B5 _H	PMCON1 Reset: 00 _H Power Mode Control Register 1	Bit Field	0	CDC_ DIS	CAN_ DIS	MDU_ DIS	T2_ DIS	CCU_ DIS	SSC_ DIS	ADC_ DIS	
		Type	r	rw	rw	rw	rw	rw	rw	rw	
B6 _H	OSC_CON Reset: 08 _H OSC Control Register	Bit Field	0			OSC PD	XPD	OSC SS	ORD RES	OSCR	
		Type	r			rw	rw	rw	rwh	rh	
B7 _H	PLL_CON Reset: 90 _H PLL Control Register	Bit Field	NDIV				VCO BYP	OSC DISC	RESL D	LOCK	
		Type	rw				rw	rw	rwh	rh	
BA _H	CMCON Reset: 10 _H Clock Control Register	Bit Field	VCO SEL	KDIV	0	FCCF G	CLKREL				
		Type	rw	rw	r	rw	rw				
BB _H	PASSWD Reset: 07 _H Password Register	Bit Field	PASS					PROT ECT_S	MODE		
		Type	wh					rh	rw		
BC _H	FEAL Reset: 00 _H Flash Error Address Register Low	Bit Field	ECCERRADDR								
		Type	rh								
BD _H	FEAH Reset: 00 _H Flash Error Address Register High	Bit Field	ECCERRADDR								
		Type	rh								

Functional Description
Table 7 SCU Register Overview (cont'd)

Addr	Register Name	Bit	7	6	5	4	3	2	1	0
BE _H	COCON Reset: 00 _H Clock Output Control Register	Bit Field	0		TLEN	COUT S	COREL			
		Type	r		rw	rw	rw			
E9 _H	MISC_CON Reset: 00 _H Miscellaneous Control Register	Bit Field	0							DFLAS HEN
		Type	r							rwh
RMAP = 0, PAGE 3										
B3 _H	XADDRH Reset: F0 _H On-chip XRAM Address Higher Order	Bit Field	ADDRH							
		Type	rw							
B4 _H	IRCON3 Reset: 00 _H Interrupt Request Register 3	Bit Field	0		CANS RC5	CCU6 SR1	0		CANS RC4	CCU6 SR0
		Type	r		rwh	rwh	r		rwh	rwh
B5 _H	IRCON4 Reset: 00 _H Interrupt Request Register 4	Bit Field	0		CANS RC7	CCU6 SR3	0		CANS RC6	CCU6 SR2
		Type	r		rwh	rwh	r		rwh	rwh
B7 _H	MODPISEL1 Reset: 00 _H Peripheral Input Select Register 1	Bit Field	EXINT 6IS	0		UR1RIS	T21EX IS	JTAGT DIS1	JTAGT CKS1	
		Type	rw	r		rw	rw	rw	rw	
BA _H	MODPISEL2 Reset: 00 _H Peripheral Input Select Register 2	Bit Field	0			T21IS	T2IS	T1IS	T0IS	
		Type	r			rw	rw	rw	rw	
BB _H	PMCON2 Reset: 00 _H Power Mode Control Register 2	Bit Field	0						UART 1_DIS	T21_D IS
		Type	r						rw	rw
BD _H	MODSUSP Reset: 01 _H Module Suspend Control Register	Bit Field	0		T21SU SP	T2SUS P	T13SU SP	T12SU SP	WDT SUSP	
		Type	r		rw	rw	rw	rw	rw	

3.2.4.5 WDT Registers

The WDT SFRs can be accessed in the mapped memory area (RMAP = 1).

Table 8 WDT Register Overview

Addr	Register Name	Bit	7	6	5	4	3	2	1	0
RMAP = 1										
BB _H	WDTCON Reset: 00 _H Watchdog Timer Control Register	Bit Field	0		WINB EN	WDTP R	0	WDTE N	WDTR S	WDTI N
		Type	r		rw	rh	r	rw	rwh	rw
BC _H	WDTREL Reset: 00 _H Watchdog Timer Reload Register	Bit Field	WDTREL							
		Type	rw							
BD _H	WDTWINB Reset: 00 _H Watchdog Window-Boundary Count Register	Bit Field	WDTWINB							
		Type	rw							

Functional Description
Table 8 WDT Register Overview (cont'd)

Addr	Register Name	Bit	7	6	5	4	3	2	1	0
BE _H	WDTL Reset: 00_H Watchdog Timer Register Low	Bit Field	WDT							
		Type	rh							
BF _H	WDTH Reset: 00_H Watchdog Timer Register High	Bit Field	WDT							
		Type	rh							

3.2.4.6 Port Registers

The Port SFRs can be accessed in the standard memory area (RMAP = 0).

Table 9 Port Register Overview

Addr	Register Name	Bit	7	6	5	4	3	2	1	0
RMAP = 0										
B2 _H	PORT_PAGE Reset: 00_H Page Register	Bit Field	OP		STNR		0	PAGE		
		Type	w		w		r	rw		
RMAP = 0, PAGE 0										
80 _H	P0_DATA Reset: 00_H P0 Data Register	Bit Field	P7	P6	P5	P4	P3	P2	P1	P0
		Type	rw	rw	rw	rw	rw	rw	rw	rw
86 _H	P0_DIR Reset: 00_H P0 Direction Register	Bit Field	P7	P6	P5	P4	P3	P2	P1	P0
		Type	rw	rw	rw	rw	rw	rw	rw	rw
90 _H	P1_DATA Reset: 00_H P1 Data Register	Bit Field	P7	P6	P5	P4	P3	P2	P1	P0
		Type	rw	rw	rw	rw	rw	rw	rw	rw
91 _H	P1_DIR Reset: 00_H P1 Direction Register	Bit Field	P7	P6	P5	P4	P3	P2	P1	P0
		Type	rw	rw	rw	rw	rw	rw	rw	rw
92 _H	P5_DATA Reset: 00_H P5 Data Register	Bit Field	P7	P6	P5	P4	P3	P2	P1	P0
		Type	rw	rw	rw	rw	rw	rw	rw	rw
93 _H	P5_DIR Reset: 00_H P5 Direction Register	Bit Field	P7	P6	P5	P4	P3	P2	P1	P0
		Type	rw	rw	rw	rw	rw	rw	rw	rw
A0 _H	P2_DATA Reset: 00_H P2 Data Register	Bit Field	P7	P6	P5	P4	P3	P2	P1	P0
		Type	rw	rw	rw	rw	rw	rw	rw	rw
A1 _H	P2_DIR Reset: 00_H P2 Direction Register	Bit Field	P7	P6	P5	P4	P3	P2	P1	P0
		Type	rw	rw	rw	rw	rw	rw	rw	rw
B0 _H	P3_DATA Reset: 00_H P3 Data Register	Bit Field	P7	P6	P5	P4	P3	P2	P1	P0
		Type	rw	rw	rw	rw	rw	rw	rw	rw
B1 _H	P3_DIR Reset: 00_H P3 Direction Register	Bit Field	P7	P6	P5	P4	P3	P2	P1	P0
		Type	rw	rw	rw	rw	rw	rw	rw	rw
C8 _H	P4_DATA Reset: 00_H P4 Data Register	Bit Field	P7	P6	P5	P4	P3	P2	P1	P0
		Type	rw	rw	rw	rw	rw	rw	rw	rw
C9 _H	P4_DIR Reset: 00_H P4 Direction Register	Bit Field	P7	P6	P5	P4	P3	P2	P1	P0
		Type	rw	rw	rw	rw	rw	rw	rw	rw

Functional Description
Table 9 Port Register Overview (cont'd)

Addr	Register Name	Bit	7	6	5	4	3	2	1	0
RMAP = 0, PAGE 1										
80 _H	P0_PUDESEL Reset: FF _H P0 Pull-Up/Pull-Down Select Register	Bit Field	P7	P6	P5	P4	P3	P2	P1	P0
		Type	rw	rw	rw	rw	rw	rw	rw	rw
86 _H	P0_PUDEN Reset: C4 _H P0 Pull-Up/Pull-Down Enable Register	Bit Field	P7	P6	P5	P4	P3	P2	P1	P0
		Type	rw	rw	rw	rw	rw	rw	rw	rw
90 _H	P1_PUDESEL Reset: FF _H P1 Pull-Up/Pull-Down Select Register	Bit Field	P7	P6	P5	P4	P3	P2	P1	P0
		Type	rw	rw	rw	rw	rw	rw	rw	rw
91 _H	P1_PUDEN Reset: FF _H P1 Pull-Up/Pull-Down Enable Register	Bit Field	P7	P6	P5	P4	P3	P2	P1	P0
		Type	rw	rw	rw	rw	rw	rw	rw	rw
92 _H	P5_PUDESEL Reset: FF _H P5 Pull-Up/Pull-Down Select Register	Bit Field	P7	P6	P5	P4	P3	P2	P1	P0
		Type	rw	rw	rw	rw	rw	rw	rw	rw
93 _H	P5_PUDEN Reset: FF _H P5 Pull-Up/Pull-Down Enable Register	Bit Field	P7	P6	P5	P4	P3	P2	P1	P0
		Type	rw	rw	rw	rw	rw	rw	rw	rw
A0 _H	P2_PUDESEL Reset: FF _H P2 Pull-Up/Pull-Down Select Register	Bit Field	P7	P6	P5	P4	P3	P2	P1	P0
		Type	rw	rw	rw	rw	rw	rw	rw	rw
A1 _H	P2_PUDEN Reset: 00 _H P2 Pull-Up/Pull-Down Enable Register	Bit Field	P7	P6	P5	P4	P3	P2	P1	P0
		Type	rw	rw	rw	rw	rw	rw	rw	rw
B0 _H	P3_PUDESEL Reset: BF _H P3 Pull-Up/Pull-Down Select Register	Bit Field	P7	P6	P5	P4	P3	P2	P1	P0
		Type	rw	rw	rw	rw	rw	rw	rw	rw
B1 _H	P3_PUDEN Reset: 40 _H P3 Pull-Up/Pull-Down Enable Register	Bit Field	P7	P6	P5	P4	P3	P2	P1	P0
		Type	rw	rw	rw	rw	rw	rw	rw	rw
C8 _H	P4_PUDESEL Reset: FF _H P4 Pull-Up/Pull-Down Select Register	Bit Field	P7	P6	P5	P4	P3	P2	P1	P0
		Type	rw	rw	rw	rw	rw	rw	rw	rw
C9 _H	P4_PUDEN Reset: 04 _H P4 Pull-Up/Pull-Down Enable Register	Bit Field	P7	P6	P5	P4	P3	P2	P1	P0
		Type	rw	rw	rw	rw	rw	rw	rw	rw
RMAP = 0, PAGE 2										
80 _H	P0_ALTSEL0 Reset: 00 _H P0 Alternate Select 0 Register	Bit Field	P7	P6	P5	P4	P3	P2	P1	P0
		Type	rw	rw	rw	rw	rw	rw	rw	rw
86 _H	P0_ALTSEL1 Reset: 00 _H P0 Alternate Select 1 Register	Bit Field	P7	P6	P5	P4	P3	P2	P1	P0
		Type	rw	rw	rw	rw	rw	rw	rw	rw
90 _H	P1_ALTSEL0 Reset: 00 _H P1 Alternate Select 0 Register	Bit Field	P7	P6	P5	P4	P3	P2	P1	P0
		Type	rw	rw	rw	rw	rw	rw	rw	rw
91 _H	P1_ALTSEL1 Reset: 00 _H P1 Alternate Select 1 Register	Bit Field	P7	P6	P5	P4	P3	P2	P1	P0
		Type	rw	rw	rw	rw	rw	rw	rw	rw
92 _H	P5_ALTSEL0 Reset: 00 _H P5 Alternate Select 0 Register	Bit Field	P7	P6	P5	P4	P3	P2	P1	P0
		Type	rw	rw	rw	rw	rw	rw	rw	rw

Functional Description
Table 9 Port Register Overview (cont'd)

Addr	Register Name	Bit	7	6	5	4	3	2	1	0
93 _H	P5_ALTSEL1 Reset: 00 _H P5 Alternate Select 1 Register	Bit Field	P7	P6	P5	P4	P3	P2	P1	P0
		Type	rw	rw	rw	rw	rw	rw	rw	rw
B0 _H	P3_ALTSEL0 Reset: 00 _H P3 Alternate Select 0 Register	Bit Field	P7	P6	P5	P4	P3	P2	P1	P0
		Type	rw	rw	rw	rw	rw	rw	rw	rw
B1 _H	P3_ALTSEL1 Reset: 00 _H P3 Alternate Select 1 Register	Bit Field	P7	P6	P5	P4	P3	P2	P1	P0
		Type	rw	rw	rw	rw	rw	rw	rw	rw
C8 _H	P4_ALTSEL0 Reset: 00 _H P4 Alternate Select 0 Register	Bit Field	P7	P6	P5	P4	P3	P2	P1	P0
		Type	rw	rw	rw	rw	rw	rw	rw	rw
C9 _H	P4_ALTSEL1 Reset: 00 _H P4 Alternate Select 1 Register	Bit Field	P7	P6	P5	P4	P3	P2	P1	P0
		Type	rw	rw	rw	rw	rw	rw	rw	rw
RMAP = 0, PAGE 3										
80 _H	P0_OD Reset: 00 _H P0 Open Drain Control Register	Bit Field	P7	P6	P5	P4	P3	P2	P1	P0
		Type	rw	rw	rw	rw	rw	rw	rw	rw
90 _H	P1_OD Reset: 00 _H P1 Open Drain Control Register	Bit Field	P7	P6	P5	P4	P3	P2	P1	P0
		Type	rw	rw	rw	rw	rw	rw	rw	rw
92 _H	P5_OD Reset: 00 _H P5 Open Drain Control Register	Bit Field	P7	P6	P5	P4	P3	P2	P1	P0
		Type	rw	rw	rw	rw	rw	rw	rw	rw
B0 _H	P3_OD Reset: 00 _H P3 Open Drain Control Register	Bit Field	P7	P6	P5	P4	P3	P2	P1	P0
		Type	rw	rw	rw	rw	rw	rw	rw	rw
C8 _H	P4_OD Reset: 00 _H P4 Open Drain Control Register	Bit Field	P7	P6	P5	P4	P3	P2	P1	P0
		Type	rw	rw	rw	rw	rw	rw	rw	rw

3.2.4.7 ADC Registers

The ADC SFRs can be accessed in the standard memory area (RMAP = 0).

Table 10 ADC Register Overview

Addr	Register Name	Bit	7	6	5	4	3	2	1	0
RMAP = 0										
D1 _H	ADC_PAGE Reset: 00 _H Page Register	Bit Field	OP		STNR		0	PAGE		
		Type	w		w		r	rw		
RMAP = 0, PAGE 0										
CA _H	ADC_GLOBCTR Reset: 30 _H Global Control Register	Bit Field	ANON	DW	CTC		0			
		Type	rw	rw	rw		r			
CB _H	ADC_GLOBSTR Reset: 00 _H Global Status Register	Bit Field	0		CHNR			0	SAMP LE	BUSY
		Type	r		rh			r	rh	rh
CC _H	ADC_PRAR Reset: 00 _H Priority and Arbitration Register	Bit Field	ASEN 1	ASEN 0	0	ARBM	CSM1	PRI01	CSM0	PRI00
		Type	rw	rw	r	rw	rw	rw	rw	rw

Functional Description
Table 10 ADC Register Overview (cont'd)

Addr	Register Name	Bit	7	6	5	4	3	2	1	0
CD _H	ADC_LCBR Reset: B7 _H Limit Check Boundary Register	Bit Field	BOUND1				BOUND0			
		Type	rw				rw			
CE _H	ADC_INPCR0 Reset: 00 _H Input Class 0 Register	Bit Field	STC							
		Type	rw							
CF _H	ADC_ETRCR Reset: 00 _H External Trigger Control Register	Bit Field	SYNE N1	SYNE N0	ETRSEL1			ETRSEL0		
		Type	rw	rw	rw			rw		
RMAP = 0, PAGE 1										
CA _H	ADC_CHCTR0 Reset: 00 _H Channel Control Register 0	Bit Field	0	LCC			0	RESRSEL		
		Type	r	rw			r	rw		
CB _H	ADC_CHCTR1 Reset: 00 _H Channel Control Register 1	Bit Field	0	LCC			0	RESRSEL		
		Type	r	rw			r	rw		
CC _H	ADC_CHCTR2 Reset: 00 _H Channel Control Register 2	Bit Field	0	LCC			0	RESRSEL		
		Type	r	rw			r	rw		
CD _H	ADC_CHCTR3 Reset: 00 _H Channel Control Register 3	Bit Field	0	LCC			0	RESRSEL		
		Type	r	rw			r	rw		
CE _H	ADC_CHCTR4 Reset: 00 _H Channel Control Register 4	Bit Field	0	LCC			0	RESRSEL		
		Type	r	rw			r	rw		
CF _H	ADC_CHCTR5 Reset: 00 _H Channel Control Register 5	Bit Field	0	LCC			0	RESRSEL		
		Type	r	rw			r	rw		
D2 _H	ADC_CHCTR6 Reset: 00 _H Channel Control Register 6	Bit Field	0	LCC			0	RESRSEL		
		Type	r	rw			r	rw		
D3 _H	ADC_CHCTR7 Reset: 00 _H Channel Control Register 7	Bit Field	0	LCC			0	RESRSEL		
		Type	r	rw			r	rw		
RMAP = 0, PAGE 2										
CA _H	ADC_RESR0L Reset: 00 _H Result Register 0 Low	Bit Field	RESULT		0	VF	DRC	CHNR		
		Type	rh		r	rh	rh	rh		
CB _H	ADC_RESR0H Reset: 00 _H Result Register 0 High	Bit Field	RESULT							
		Type	rh							
CC _H	ADC_RESR1L Reset: 00 _H Result Register 1 Low	Bit Field	RESULT		0	VF	DRC	CHNR		
		Type	rh		r	rh	rh	rh		
CD _H	ADC_RESR1H Reset: 00 _H Result Register 1 High	Bit Field	RESULT							
		Type	rh							
CE _H	ADC_RESR2L Reset: 00 _H Result Register 2 Low	Bit Field	RESULT		0	VF	DRC	CHNR		
		Type	rh		r	rh	rh	rh		
CF _H	ADC_RESR2H Reset: 00 _H Result Register 2 High	Bit Field	RESULT							
		Type	rh							
D2 _H	ADC_RESR3L Reset: 00 _H Result Register 3 Low	Bit Field	RESULT		0	VF	DRC	CHNR		
		Type	rh		r	rh	rh	rh		

Functional Description
Table 10 ADC Register Overview (cont'd)

Addr	Register Name	Bit	7	6	5	4	3	2	1	0	
D3 _H	ADC_RESR3H Reset: 00 _H Result Register 3 High	Bit Field	RESULT								
		Type	rh								
RMAP = 0, PAGE 3											
CA _H	ADC_RESRA0L Reset: 00 _H Result Register 0, View A Low	Bit Field	RESULT			VF	DRC	CHNR			
		Type	rh			rh	rh	rh			
CB _H	ADC_RESRA0H Reset: 00 _H Result Register 0, View A High	Bit Field	RESULT								
		Type	rh								
CC _H	ADC_RESRA1L Reset: 00 _H Result Register 1, View A Low	Bit Field	RESULT			VF	DRC	CHNR			
		Type	rh			rh	rh	rh			
CD _H	ADC_RESRA1H Reset: 00 _H Result Register 1, View A High	Bit Field	RESULT								
		Type	rh								
CE _H	ADC_RESRA2L Reset: 00 _H Result Register 2, View A Low	Bit Field	RESULT			VF	DRC	CHNR			
		Type	rh			rh	rh	rh			
CF _H	ADC_RESRA2H Reset: 00 _H Result Register 2, View A High	Bit Field	RESULT								
		Type	rh								
D2 _H	ADC_RESRA3L Reset: 00 _H Result Register 3, View A Low	Bit Field	RESULT			VF	DRC	CHNR			
		Type	rh			rh	rh	rh			
D3 _H	ADC_RESRA3H Reset: 00 _H Result Register 3, View A High	Bit Field	RESULT								
		Type	rh								
RMAP = 0, PAGE 4											
CA _H	ADC_RCR0 Reset: 00 _H Result Control Register 0	Bit Field	VFCT R	WFR	0	IEN	0			DRCT R	
		Type	rw	rw	r	rw	r			rw	
CB _H	ADC_RCR1 Reset: 00 _H Result Control Register 1	Bit Field	VFCT R	WFR	0	IEN	0			DRCT R	
		Type	rw	rw	r	rw	r			rw	
CC _H	ADC_RCR2 Reset: 00 _H Result Control Register 2	Bit Field	VFCT R	WFR	0	IEN	0			DRCT R	
		Type	rw	rw	r	rw	r			rw	
CD _H	ADC_RCR3 Reset: 00 _H Result Control Register 3	Bit Field	VFCT R	WFR	0	IEN	0			DRCT R	
		Type	rw	rw	r	rw	r			rw	
CE _H	ADC_VFCR Reset: 00 _H Valid Flag Clear Register	Bit Field	0				VFC3	VFC2	VFC1	VFC0	
		Type	r				w	w	w	w	
RMAP = 0, PAGE 5											
CA _H	ADC_CHINFR Reset: 00 _H Channel Interrupt Flag Register	Bit Field	CHINF 7	CHINF 6	CHINF 5	CHINF 4	CHINF 3	CHINF 2	CHINF 1	CHINF 0	
		Type	rh	rh	rh	rh	rh	rh	rh	rh	
CB _H	ADC_CHINCR Reset: 00 _H Channel Interrupt Clear Register	Bit Field	CHINC 7	CHINC 6	CHINC 5	CHINC 4	CHINC 3	CHINC 2	CHINC 1	CHINC 0	
		Type	w	w	w	w	w	w	w	w	

Functional Description
Table 10 ADC Register Overview (cont'd)

Addr	Register Name	Bit	7	6	5	4	3	2	1	0
CC _H	ADC_CHINSR Reset: 00 _H Channel Interrupt Set Register	Bit Field	CHINS 7	CHINS 6	CHINS 5	CHINS 4	CHINS 3	CHINS 2	CHINS 1	CHINS 0
		Type	w	w	w	w	w	w	w	w
CD _H	ADC_CHINPR Reset: 00 _H Channel Interrupt Node Pointer Register	Bit Field	CHINP 7	CHINP 6	CHINP 5	CHINP 4	CHINP 3	CHINP 2	CHINP 1	CHINP 0
		Type	rw	rw	rw	rw	rw	rw	rw	rw
CE _H	ADC_EVINFR Reset: 00 _H Event Interrupt Flag Register	Bit Field	EVINF 7	EVINF 6	EVINF 5	EVINF 4	0	0	EVINF 1	EVINF 0
		Type	rh	rh	rh	rh	r	r	rh	rh
CF _H	ADC_EVINCR Reset: 00 _H Event Interrupt Clear Flag Register	Bit Field	EVINC 7	EVINC 6	EVINC 5	EVINC 4	0	0	EVINC 1	EVINC 0
		Type	w	w	w	w	r	r	w	w
D2 _H	ADC_EVINSR Reset: 00 _H Event Interrupt Set Flag Register	Bit Field	EVINS 7	EVINS 6	EVINS 5	EVINS 4	0	0	EVINS 1	EVINS 0
		Type	w	w	w	w	r	r	w	w
D3 _H	ADC_EVINPR Reset: 00 _H Event Interrupt Node Pointer Register	Bit Field	EVINP 7	EVINP 6	EVINP 5	EVINP 4	0	0	EVINP 1	EVINP 0
		Type	rw	rw	rw	rw	r	r	rw	rw
RMAP = 0, PAGE 6										
CA _H	ADC_CRCR1 Reset: 00 _H Conversion Request Control Register 1	Bit Field	CH7	CH6	CH5	CH4	0	0	0	0
		Type	rwh	rwh	rwh	rwh	r	r	r	r
CB _H	ADC_CRPR1 Reset: 00 _H Conversion Request Pending Register 1	Bit Field	CHP7	CHP6	CHP5	CHP4	0	0	0	0
		Type	rwh	rwh	rwh	rwh	r	r	r	r
CC _H	ADC_CRMR1 Reset: 00 _H Conversion Request Mode Register 1	Bit Field	Rsv	LDEV	CLRP ND	SCAN	ENSI	ENTR	0	ENGT
		Type	r	w	w	rw	rw	rw	r	rw
CD _H	ADC_QMR0 Reset: 00 _H Queue Mode Register 0	Bit Field	CEV	TREV	FLUS H	CLRV	0	ENTR	0	ENGT
		Type	w	w	w	w	r	rw	r	rw
CE _H	ADC_QSR0 Reset: 20 _H Queue Status Register 0	Bit Field	Rsv	0	EMPT Y	EV	0	0	0	FILL
		Type	r	r	rh	rh	r	r	r	rh
CF _H	ADC_Q0R0 Reset: 00 _H Queue 0 Register 0	Bit Field	EXTR	ENSI	RF	V	0	0	REQCHNR	
		Type	rh	rh	rh	rh	r	r	rh	
D2 _H	ADC_QBUR0 Reset: 00 _H Queue Backup Register 0	Bit Field	EXTR	ENSI	RF	V	0	0	REQCHNR	
		Type	rh	rh	rh	rh	r	r	rh	
D2 _H	ADC_QINR0 Reset: 00 _H Queue Input Register 0	Bit Field	EXTR	ENSI	RF	0	0	0	REQCHNR	
		Type	w	w	w	r	r	r	w	

Functional Description
3.2.4.8 Timer 2 Registers

The Timer 2 SFRs can be accessed in the standard memory area (RMAP = 0).

Table 11 T2 Register Overview

Addr	Register Name	Bit	7	6	5	4	3	2	1	0
RMAP = 0										
C0 _H	T2_T2CON Reset: 00 _H Timer 2 Control Register	Bit Field	TF2	EXF2	0		EXEN 2	TR2	$\overline{C/T2}$	$\overline{CP/RL2}$
		Type	rwh	rwh	r		rw	rwh	rw	rw
C1 _H	T2_T2MOD Reset: 00 _H Timer 2 Mode Register	Bit Field	T2RE GS	T2RH EN	EDGE SEL	PREN	T2PRE			DCEN
		Type	rw	rw	rw	rw	rw	rw	rw	rw
C2 _H	T2_RC2L Reset: 00 _H Timer 2 Reload/Capture Register Low	Bit Field	RC2							
		Type	rwh							
C3 _H	T2_RC2H Reset: 00 _H Timer 2 Reload/Capture Register High	Bit Field	RC2							
		Type	rwh							
C4 _H	T2_T2L Reset: 00 _H Timer 2 Register Low	Bit Field	THL2							
		Type	rwh							
C5 _H	T2_T2H Reset: 00 _H Timer 2 Register High	Bit Field	THL2							
		Type	rwh							

3.2.4.9 Timer 21 Registers

The Timer 21 SFRs can be accessed in the mapped memory area (RMAP = 1).

Table 12 T21 Register Overview

Addr	Register Name	Bit	7	6	5	4	3	2	1	0
RMAP = 1										
C0 _H	T21_T2CON Reset: 00 _H Timer 2 Control Register	Bit Field	TF2	EXF2	0		EXEN 2	TR2	$\overline{C/T2}$	$\overline{CP/RL2}$
		Type	rwh	rwh	r		rw	rwh	rw	rw
C1 _H	T21_T2MOD Reset: 00 _H Timer 2 Mode Register	Bit Field	T2RE GS	T2RH EN	EDGE SEL	PREN	T2PRE			DCEN
		Type	rw	rw	rw	rw	rw	rw	rw	rw
C2 _H	T21_RC2L Reset: 00 _H Timer 2 Reload/Capture Register Low	Bit Field	RC2							
		Type	rwh							
C3 _H	T21_RC2H Reset: 00 _H Timer 2 Reload/Capture Register High	Bit Field	RC2							
		Type	rwh							
C4 _H	T21_T2L Reset: 00 _H Timer 2 Register Low	Bit Field	THL2							
		Type	rwh							

Functional Description
Table 12 T21 Register Overview (cont'd)

Addr	Register Name	Bit	7	6	5	4	3	2	1	0
C5 _H	T21_T2H Reset: 00_H Timer 2 Register High	Bit Field	THL2							
		Type	rwh							

3.2.4.10 CCU6 Registers

The CCU6 SFRs can be accessed in the standard memory area (RMAP = 0).

Table 13 CCU6 Register Overview

Addr	Register Name	Bit	7	6	5	4	3	2	1	0
RMAP = 0										
A3 _H	CCU6_PAGE Reset: 00_H Page Register	Bit Field	OP		STNR		0	PAGE		
		Type	w		w		r	rw		
RMAP = 0, PAGE 0										
9A _H	CCU6_CC63SRL Reset: 00_H Capture/Compare Shadow Register for Channel CC63 Low	Bit Field	CC63SL							
		Type	rw							
9B _H	CCU6_CC63SRH Reset: 00_H Capture/Compare Shadow Register for Channel CC63 High	Bit Field	CC63SH							
		Type	rw							
9C _H	CCU6_TCTR4L Reset: 00_H Timer Control Register 4 Low	Bit Field	T12 STD	T12 STR	0		DT RES	T12 RES	T12R S	T12R R
		Type	w	w	r		w	w	w	w
9D _H	CCU6_TCTR4H Reset: 00_H Timer Control Register 4 High	Bit Field	T13 STD	T13 STR	0			T13 RES	T13R S	T13R R
		Type	w	w	r			w	w	w
9E _H	CCU6_MCMOUTSL Reset: 00_H Multi-Channel Mode Output Shadow Register Low	Bit Field	STRM CM	0	MCMPS					
		Type	w	r	rw					
9F _H	CCU6_MCMOUTSH Reset: 00_H Multi-Channel Mode Output Shadow Register High	Bit Field	STRH P	0	CURHS			EXPHS		
		Type	w	r	rw			rw		
A4 _H	CCU6_ISRL Reset: 00_H Capture/Compare Interrupt Status Reset Register Low	Bit Field	RT12 PM	RT12 OM	RCC6 2F	RCC6 2R	RCC6 1F	RCC6 1R	RCC6 0F	RCC6 0R
		Type	w	w	w	w	w	w	w	w
A5 _H	CCU6_ISRH Reset: 00_H Capture/Compare Interrupt Status Reset Register High	Bit Field	RSTR	RIDLE	RWH E	RCHE	0	RTRP F	RT13 PM	RT13 CM
		Type	w	w	w	w	r	w	w	w
A6 _H	CCU6_CMPMODIFL Reset: 00_H Compare State Modification Register Low	Bit Field	0	MCC6 3S	0			MCC6 2S	MCC6 1S	MCC6 0S
		Type	r	w	r			w	w	w
A7 _H	CCU6_CMPMODIFH Reset: 00_H Compare State Modification Register High	Bit Field	0	MCC6 3R	0			MCC6 2R	MCC6 1R	MCC6 0R
		Type	r	w	r			w	w	w

Functional Description
Table 13 CCU6 Register Overview (cont'd)

Addr	Register Name	Bit	7	6	5	4	3	2	1	0
FA _H	CCU6_CC60SRL Reset: 00_H Capture/Compare Shadow Register for Channel CC60 Low	Bit Field	CC60SL							
		Type	rwh							
FB _H	CCU6_CC60SRH Reset: 00_H Capture/Compare Shadow Register for Channel CC60 High	Bit Field	CC60SH							
		Type	rwh							
FC _H	CCU6_CC61SRL Reset: 00_H Capture/Compare Shadow Register for Channel CC61 Low	Bit Field	CC61SL							
		Type	rwh							
FD _H	CCU6_CC61SRH Reset: 00_H Capture/Compare Shadow Register for Channel CC61 High	Bit Field	CC61SH							
		Type	rwh							
FE _H	CCU6_CC62SRL Reset: 00_H Capture/Compare Shadow Register for Channel CC62 Low	Bit Field	CC62SL							
		Type	rwh							
FF _H	CCU6_CC62SRH Reset: 00_H Capture/Compare Shadow Register for Channel CC62 High	Bit Field	CC62SH							
		Type	rwh							
RMAP = 0, PAGE 1										
9A _H	CCU6_CC63RL Reset: 00_H Capture/Compare Register for Channel CC63 Low	Bit Field	CC63VL							
		Type	rh							
9B _H	CCU6_CC63RH Reset: 00_H Capture/Compare Register for Channel CC63 High	Bit Field	CC63VH							
		Type	rh							
9C _H	CCU6_T12PRL Reset: 00_H Timer T12 Period Register Low	Bit Field	T12PVL							
		Type	rwh							
9D _H	CCU6_T12PRH Reset: 00_H Timer T12 Period Register High	Bit Field	T12PVH							
		Type	rwh							
9E _H	CCU6_T13PRL Reset: 00_H Timer T13 Period Register Low	Bit Field	T13PVL							
		Type	rwh							
9F _H	CCU6_T13PRH Reset: 00_H Timer T13 Period Register High	Bit Field	T13PVH							
		Type	rwh							
A4 _H	CCU6_T12DTCL Reset: 00_H Dead-Time Control Register for Timer T12 Low	Bit Field	DTM							
		Type	rw							
A5 _H	CCU6_T12DTCH Reset: 00_H Dead-Time Control Register for Timer T12 High	Bit Field	0	DTR2	DTR1	DTR0	0	DTE2	DTE1	DTE0
		Type	r	rh	rh	rh	r	rw	rw	rw
A6 _H	CCU6_TCTR0L Reset: 00_H Timer Control Register 0 Low	Bit Field	CTM	CDIR	STE1 2	T12R	T12 PRE	T12CLK		
		Type	rw	rh	rh	rh	rw	rw		
A7 _H	CCU6_TCTR0H Reset: 00_H Timer Control Register 0 High	Bit Field	0	STE1 3	T13R	T13 PRE	T13CLK			
		Type	r	rh	rh	rw	rw			
FA _H	CCU6_CC60RL Reset: 00_H Capture/Compare Register for Channel CC60 Low	Bit Field	CC60VL							
		Type	rh							

Functional Description
Table 13 CCU6 Register Overview (cont'd)

Addr	Register Name	Bit	7	6	5	4	3	2	1	0
FB _H	CCU6_CC60RH Reset: 00_H Capture/Compare Register for Channel CC60 High	Bit Field	CC60VH							
		Type	rh							
FC _H	CCU6_CC61RL Reset: 00_H Capture/Compare Register for Channel CC61 Low	Bit Field	CC61VL							
		Type	rh							
FD _H	CCU6_CC61RH Reset: 00_H Capture/Compare Register for Channel CC61 High	Bit Field	CC61VH							
		Type	rh							
FE _H	CCU6_CC62RL Reset: 00_H Capture/Compare Register for Channel CC62 Low	Bit Field	CC62VL							
		Type	rh							
FF _H	CCU6_CC62RH Reset: 00_H Capture/Compare Register for Channel CC62 High	Bit Field	CC62VH							
		Type	rh							
RMAP = 0, PAGE 2										
9A _H	CCU6_T12MSELL Reset: 00_H T12 Capture/Compare Mode Select Register Low	Bit Field	MSEL61				MSEL60			
		Type	rw				rw			
9B _H	CCU6_T12MSELH Reset: 00_H T12 Capture/Compare Mode Select Register High	Bit Field	DBYP	HSYNC			MSEL62			
		Type	rw	rw			rw			
9C _H	CCU6_IENL Reset: 00_H Capture/Compare Interrupt Enable Register Low	Bit Field	ENT1 2 PM	ENT1 2 OM	ENCC 62F	ENCC 62R	ENCC 61F	ENCC 61R	ENCC 60F	ENCC 60R
		Type	rw	rw	rw	rw	rw	rw	rw	rw
9D _H	CCU6_IENH Reset: 00_H Capture/Compare Interrupt Enable Register High	Bit Field	EN STR	EN IDLE	EN WHE	EN CHE	0	EN TRPF	ENT1 3PM	ENT1 3CM
		Type	rw	rw	rw	rw	r	rw	rw	rw
9E _H	CCU6_INPL Reset: 40_H Capture/Compare Interrupt Node Pointer Register Low	Bit Field	INPCHE		INPCC62		INPCC61		INPCC60	
		Type	rw		rw		rw		rw	
9F _H	CCU6_INPH Reset: 39_H Capture/Compare Interrupt Node Pointer Register High	Bit Field	0		INPT13		INPT12		INPERR	
		Type	r		rw		rw		rw	
A4 _H	CCU6_ISSL Reset: 00_H Capture/Compare Interrupt Status Set Register Low	Bit Field	ST12 PM	ST12 OM	SCC6 2F	SCC6 2R	SCC6 1F	SCC6 1R	SCC6 0F	SCC6 0R
		Type	w	w	w	w	w	w	w	w
A5 _H	CCU6_ISSH Reset: 00_H Capture/Compare Interrupt Status Set Register High	Bit Field	SSTR	SIDLE	SWHE	SCHE	SWH C	STRP F	ST13 PM	ST13 CM
		Type	w	w	w	w	w	w	w	w
A6 _H	CCU6_PSLR Reset: 00_H Passive State Level Register	Bit Field	PSL63	0	PSL					
		Type	rwh	r	rwh					
A7 _H	CCU6_MCMCTR Reset: 00_H Multi-Channel Mode Control Register	Bit Field	0		SWSYN		0	SWSEL		
		Type	r		rw		r	rw		
FA _H	CCU6_TCTR2L Reset: 00_H Timer Control Register 2 Low	Bit Field	0	T13TED		T13TEC			T13 SSC	T12 SSC
		Type	r	rw		rw			rw	rw

Functional Description
Table 13 CCU6 Register Overview (cont'd)

Addr	Register Name	Bit	7	6	5	4	3	2	1	0	
FB _H	CCU6_TCTR2H Reset: 00 _H Timer Control Register 2 High	Bit Field	0				T13RSEL		T12RSEL		
		Type	r				rw		rw		
FC _H	CCU6_MODCTRL Reset: 00 _H Modulation Control Register Low	Bit Field	MCM EN	0	T12MODEN						
		Type	rw	r	rw						
FD _H	CCU6_MODCTRH Reset: 00 _H Modulation Control Register High	Bit Field	ECT1 30	0	T13MODEN						
		Type	rw	r	rw						
FE _H	CCU6_TRPCTRL Reset: 00 _H Trap Control Register Low	Bit Field	0				TRPM 2	TRPM 1	TRPM 0		
		Type	r				rw	rw	rw		
FF _H	CCU6_TRPCTRH Reset: 00 _H Trap Control Register High	Bit Field	TRPP EN	TRPE N13	TRPEN						
		Type	rw	rw	rw						
RMAP = 0, PAGE 3											
9A _H	CCU6_MCMOUTL Reset: 00 _H Multi-Channel Mode Output Register Low	Bit Field	0	R	MCMP						
		Type	r	rh	rh						
9B _H	CCU6_MCMOUTH Reset: 00 _H Multi-Channel Mode Output Register High	Bit Field	0		CURH			EXPH			
		Type	r		rh			rh			
9C _H	CCU6_ISL Reset: 00 _H Capture/Compare Interrupt Status Register Low	Bit Field	T12 PM	T12 OM	ICC62 F	ICC62 R	ICC61 F	ICC61 R	ICC60 F	ICC60 R	
		Type	rh	rh	rh	rh	rh	rh	rh	rh	
9D _H	CCU6_ISH Reset: 00 _H Capture/Compare Interrupt Status Register High	Bit Field	STR	IDLE	WHE	CHE	TRPS	TRPF	T13 PM	T13 CM	
		Type	rh	rh	rh	rh	rh	rh	rh	rh	
9E _H	CCU6_PISEL0L Reset: 00 _H Port Input Select Register 0 Low	Bit Field	ISTRP		ISCC62		ISCC61		ISCC60		
		Type	rw		rw		rw		rw		
9F _H	CCU6_PISEL0H Reset: 00 _H Port Input Select Register 0 High	Bit Field	IST12HR		ISPOS2		ISPOS1		ISPOS0		
		Type	rw		rw		rw		rw		
A4 _H	CCU6_PISEL2 Reset: 00 _H Port Input Select Register 2	Bit Field	0							IST13HR	
		Type	r							rw	
FA _H	CCU6_T12L Reset: 00 _H Timer T12 Counter Register Low	Bit Field	T12CVL								
		Type	rwh								
FB _H	CCU6_T12H Reset: 00 _H Timer T12 Counter Register High	Bit Field	T12CVH								
		Type	rwh								
FC _H	CCU6_T13L Reset: 00 _H Timer T13 Counter Register Low	Bit Field	T13CVL								
		Type	rwh								
FD _H	CCU6_T13H Reset: 00 _H Timer T13 Counter Register High	Bit Field	T13CVH								
		Type	rwh								

Functional Description
Table 13 CCU6 Register Overview (cont'd)

Addr	Register Name	Bit	7	6	5	4	3	2	1	0
FE _H	CCU6_CMPSTATL Reset: 00 _H Compare State Register Low	Bit Field	0	CC63 ST	CC POS2	CC POS1	CC POS0	CC62 ST	CC61 ST	CC60 ST
		Type	r	rh	rh	rh	rh	rh	rh	rh
FF _H	CCU6_CMPSTATH Reset: 00 _H Compare State Register High	Bit Field	T13IM	COU _T 63PS	COU _T 62PS	CC62 PS	COU _T 61PS	CC61 PS	COU _T 60PS	CC60 PS
		Type	rwh	rwh	rwh	rwh	rwh	rwh	rwh	rwh

3.2.4.11 UART1 Registers

The UART1 SFRs can be accessed in the mapped memory area (RMAP = 1).

Table 14 UART1 Register Overview

Addr	Register Name	Bit	7	6	5	4	3	2	1	0
RMAP = 1										
C8 _H	SCON Reset: 00 _H Serial Channel Control Register	Bit Field	SM0	SM1	SM2	REN	TB8	RB8	TI	RI
		Type	rw	rw	rw	rw	rw	rwh	rwh	rwh
C9 _H	SBUF Reset: 00 _H Serial Data Buffer Register	Bit Field	VAL							
		Type	rwh							
CA _H	BCON Reset: 00 _H Baud Rate Control Register	Bit Field	0			BRPRE			R	
		Type	r			rw			rw	
CB _H	BG Reset: 00 _H Baud Rate Timer/Reload Register	Bit Field	BR_VALUE							
		Type	rwh							
CC _H	FDCON Reset: 00 _H Fractional Divider Control Register	Bit Field	0				NDOV	FDM	FDEN	
		Type	r				rwh	rw	rw	
CD _H	FDSTEP Reset: 00 _H Fractional Divider Reload Register	Bit Field	STEP							
		Type	rw							
CE _H	FDRES Reset: 00 _H Fractional Divider Result Register	Bit Field	RESULT							
		Type	rh							

Functional Description
3.2.4.12 SSC Registers

The SSC SFRs can be accessed in the standard memory area (RMAP = 0).

Table 15 SSC Register Overview

Addr	Register Name	Bit	7	6	5	4	3	2	1	0	
RMAP = 0											
A9 _H	SSC_PISEL Reset: 00 _H Port Input Select Register	Bit Field	0					CIS	SIS	MIS	
		Type	r					rw	rw	rw	
AA _H	SSC_CONL Reset: 00 _H Control Register Low Programming Mode	Bit Field	LB	PO	PH	HB	BM				
		Type	rw	rw	rw	rw	rw				
AA _H	SSC_CONL Reset: 00 _H Control Register Low Operating Mode	Bit Field	0					BC			
		Type	r					rh			
AB _H	SSC_CONH Reset: 00 _H Control Register High Programming Mode	Bit Field	EN	MS	0	AREN	BEN	PEN	REN	TEN	
		Type	rw	rw	r	rw	rw	rw	rw	rw	
AB _H	SSC_CONH Reset: 00 _H Control Register High Operating Mode	Bit Field	EN	MS	0	BSY	BE	PE	RE	TE	
		Type	rw	rw	r	rh	rwh	rwh	rwh	rwh	
AC _H	SSC_TBL Reset: 00 _H Transmitter Buffer Register Low	Bit Field	TB_VALUE								
		Type	rw								
AD _H	SSC_RBL Reset: 00 _H Receiver Buffer Register Low	Bit Field	RB_VALUE								
		Type	rh								
AE _H	SSC_BRL Reset: 00 _H Baud Rate Timer Reload Register Low	Bit Field	BR_VALUE								
		Type	rw								
AF _H	SSC_BRH Reset: 00 _H Baud Rate Timer Reload Register High	Bit Field	BR_VALUE								
		Type	rw								

3.2.4.13 MultiCAN Registers

The MultiCAN SFRs can be accessed in the standard memory area (RMAP = 0).

Table 16 CAN Register Overview

Addr	Register Name	Bit	7	6	5	4	3	2	1	0	
RMAP = 0											
D8 _H	ADCON Reset: 00 _H CAN Address/Data Control Register	Bit Field	V3	V2	V1	V0	AUAD		BSY	RWEN	
		Type	rw	rw	rw	rw	rw		rh	rw	
D9 _H	ADL Reset: 00 _H CAN Address Register Low	Bit Field	CA9	CA8	CA7	CA6	CA5	CA4	CA3	CA2	
		Type	rwh	rwh	rwh	rwh	rwh	rwh	rwh	rwh	
DA _H	ADH Reset: 00 _H CAN Address Register High	Bit Field	0				CA13	CA12	CA11	CA10	
		Type	r				rwh	rwh	rwh	rwh	

Functional Description
Table 16 CAN Register Overview (cont'd)

Addr	Register Name	Bit	7	6	5	4	3	2	1	0
DB _H	DATA0 Reset: 00_H CAN Data Register 0	Bit Field	CD							
		Type	rwh							
DC _H	DATA1 Reset: 00_H CAN Data Register 1	Bit Field	CD							
		Type	rwh							
DD _H	DATA2 Reset: 00_H CAN Data Register 2	Bit Field	CD							
		Type	rwh							
DE _H	DATA3 Reset: 00_H CAN Data Register 3	Bit Field	CD							
		Type	rwh							

3.2.4.14 OCDS Registers

The OCDS SFRs can be accessed in the mapped memory area (RMAP = 1).

Table 17 OCDS Register Overview

Addr	Register Name	Bit	7	6	5	4	3	2	1	0
RMAP = 1										
E9 _H	MMCR2 Reset: 1U_H Monitor Mode Control 2 Register	Bit Field	STMO DE	EXBC	DSUS P	MBCO N	ALTDI	MMEP	MMOD E	JENA
		Type	rw	rw	rw	rwh	rw	rwh	rh	rh
F1 _H	MMCR Reset: 00_H Monitor Mode Control Register	Bit Field	MEXIT _P	MEXIT	0	MSTE P	MRAM S_P	MRAM S	TRF	RRF
		Type	w	rwh	r	rw	w	rwh	rh	rh
F2 _H	MMSR Reset: 00_H Monitor Mode Status Register	Bit Field	MBCA M	MBCIN	EXBF	SWBF	HWB3 F	HWB2 F	HWB1 F	HWB0 F
		Type	rw	rwh	rwh	rwh	rwh	rwh	rwh	rwh
F3 _H	MMBPCR Reset: 00_H Breakpoints Control Register	Bit Field	SWBC	HWB3C		HWB2C		HWB1 C	HWB0C	
		Type	rw	rw		rw		rw	rw	
F4 _H	MMICR Reset: 00_H Monitor Mode Interrupt Control Register	Bit Field	DVEC T	DRET R	COMR ST	MSTS EL	MMUI E_P	MMUI E	RRIE_ P	RRIE
		Type	rwh	rwh	rwh	rh	w	rw	w	rw
F5 _H	MMDR Reset: 00_H Monitor Mode Data Transfer Register Receive	Bit Field	MMRR							
		Type	rh							
F6 _H	HWBPSR Reset: 00_H Hardware Breakpoints Select Register	Bit Field	0			BPSEL _P	BPSEL			
		Type	r			w	rw			
F7 _H	HWBPDR Reset: 00_H Hardware Breakpoints Data Register	Bit Field	HWBPxx							
		Type	rw							
EB _H	MMWR1 Reset: 00_H Monitor Work Register 1	Bit Field	MMWR1							
		Type	rw							

Functional Description

Table 17 OCDS Register Overview (cont'd)

Addr	Register Name	Bit	7	6	5	4	3	2	1	0
E _C H	MMWR2 Reset: 00_H Monitor Work Register 2	Bit Field	MMWR2							
		Type	rw							

3.3 Flash Memory

The Flash memory provides an embedded user-programmable non-volatile memory, allowing fast and reliable storage of user code and data. It is operated from a single 2.5 V supply from the Embedded Voltage Regulator (EVR) and does not require additional programming or erasing voltage. The sectorization of the Flash memory allows each sector to be erased independently.

Features

- In-System Programming (ISP) via UART
- In-Application Programming (IAP)
- Error Correction Code (ECC) for dynamic correction of single-bit errors
- Background program and erase operations for CPU load minimization
- Support for aborting erase operation
- Minimum program width¹⁾ of 32-byte for D-Flash and 64-byte for P-Flash
- 1-sector minimum erase width
- 1-byte read access
- Flash is delivered in erased state (read all zeros)
- Operating supply voltage: 2.5 V \pm 7.5 %
- Read access time: $3 \times t_{\text{CCLK}} = 125 \text{ ns}^2)$
- Program time: $248256 / f_{\text{SYS}} = 2.6 \text{ ms}^3)$
- Erase time: $9807360 / f_{\text{SYS}} = 102 \text{ ms}^3)$

1) P-Flash: 64-byte wordline can only be programmed once, i.e., one gate disturb allowed.
D-Flash: 32-byte wordline can be programmed twice, i.e., two gate disturbs allowed.

2) Values shown here are typical values. $f_{\text{SYS}} = 96 \text{ MHz} \pm 7.5\%$ ($f_{\text{CCLK}} = 24 \text{ MHz} \pm 7.5\%$) is the maximum frequency range for Flash read access.

3) Values shown here are typical values. $f_{\text{SYS}} = 96 \text{ MHz} \pm 7.5\%$ is the only frequency range for Flash programming and erasing. f_{SYSmin} is used for obtaining the worst case timing.

Functional Description

Table 18 shows the Flash data retention and endurance targets.

Table 18 Flash Data Retention and Endurance (Operating Conditions apply)

Retention	Endurance ¹⁾	Size		Remarks
		$T_A = -40$ to 125 °C	$T_A = 125$ to 140 °C	
Program Flash				
20 years	1,000 cycles	up to 32 Kbytes ²⁾		for 32-Kbyte Variant
20 years	1,000 cycles	up to 24 Kbytes ²⁾		for 24-Kbyte Variant
Data Flash				
20 years	1,000 cycles ³⁾	4 Kbytes	1 Kbyte	
5 years	10,000 cycles ³⁾	1 Kbyte	256 bytes	
2 years	70,000 cycles ³⁾	512 bytes	128 bytes	
2 years	100,000 cycles ³⁾	128 bytes	32 bytes	

- 1) One cycle refers to the programming of all wordlines in a sector and erasing of sector. The Flash endurance data specified in **Table 18** is valid only if the following conditions are fulfilled:
 - the maximum number of erase cycles per Flash sector must not exceed 100,000 cycles.
 - the maximum number of erase cycles per Flash bank must not exceed 300,000 cycles.
 - the maximum number of program cycles per Flash bank must not exceed 2,500,000 cycles.
- 2) If no Flash is used for data, the Program Flash size can be up to the maximum Flash size available in the device variant. Having more Data Flash will mean less Flash is available for Program Flash.
- 3) For $T_A = 125$ to 140°C, refers to programming of second 8 bytes (bytes 8 to 15) per WL.

3.3.1 Flash Bank Sectorization

The SAA-XC886 product family offers Flash devices with either 24 Kbytes or 32 Kbytes of embedded Flash memory. Each Flash device consists of Program Flash (P-Flash) and Data Flash (D-Flash) bank(s) with different sectorization shown in **Figure 10**. Both types can be used for code and data storage. The label “Data” neither implies that the D-Flash is mapped to the data memory region, nor that it can only be used for data storage. It is used to distinguish the different Flash bank sectorizations.

The 32-Kbyte Flash device consists of 6 P-Flash and 2 D-Flash banks, while the 24-Kbyte Flash device consists of also of 6 P-Flash banks but with the upper 2 banks only 2 Kbytes each, and only 1 D-Flash bank.

The P-Flash banks are always grouped in pairs. As such, the P-Flash banks are also sometimes referred to as P-Flash bank pair. Each sector in a P-Flash bank is grouped with the corresponding sector from the other bank within a bank pair to form a P-Flash bank pair sector.

Functional Description

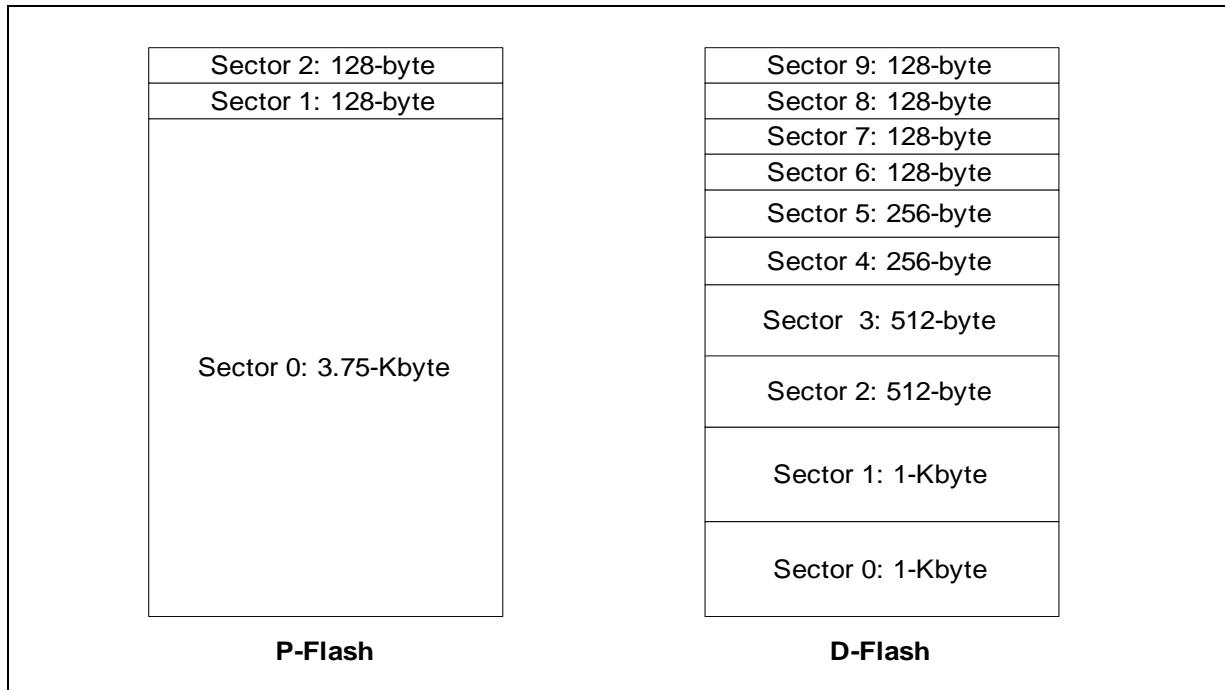

Figure 10 Flash Bank Sectorization

The internal structure of each Flash bank represents a sector architecture for flexible erase capability. The minimum erase width is always a complete sector, and sectors can be erased separately or in parallel. Contrary to standard EPROMs, erased Flash memory cells contain 0s.

The D-Flash bank is divided into more physical sectors for extended erasing and reprogramming capability; even numbers for each sector size are provided to allow greater flexibility and the ability to adapt to a wide range of application requirements.

3.3.2 Parallel Read Access of P-Flash

To enhance system performance, the P-Flash banks are configured for parallel read to allow two bytes of linear code to be read in 4 x CCLK cycles, compared to 6 x CCLK cycles if serial read is performed. This is achieved by reading two bytes in parallel from a P-Flash bank pair within the 3 x CCLK cycles access time and storing them in a cache. Subsequent read from the cache by the CPU does not require a wait state and can be completed within 1 x CCLK cycle. The result is the average instruction fetch time from the P-Flash banks is reduced and thus, the MIPS (Mega Instruction Per Second) of the system is increased.

However, if the parallel read feature is not desired due to certain timing constraints, it can be disabled by calling the parallel read disable subroutine.

3.3.3 Flash Programming Width

For the P-Flash banks, a programmed wordline (WL) must be erased before it can be reprogrammed as the Flash cells can only withstand one gate disturb. This means that the entire sector containing the WL must be erased since it is impossible to erase a single WL.

For the D-Flash bank, the same WL can be programmed twice before erasing is required as the Flash cells are able to withstand two gate disturbs. This means if the number of data bytes that needs to be written is smaller than the 32-byte minimum programming width, the user can opt to program this number of data bytes (x; where x can be any integer from 1 to 31) first and program the remaining bytes (32 - x) later. Hence, it is possible to program the same WL, for example, with 16 bytes of data two times (see [Figure 11](#))

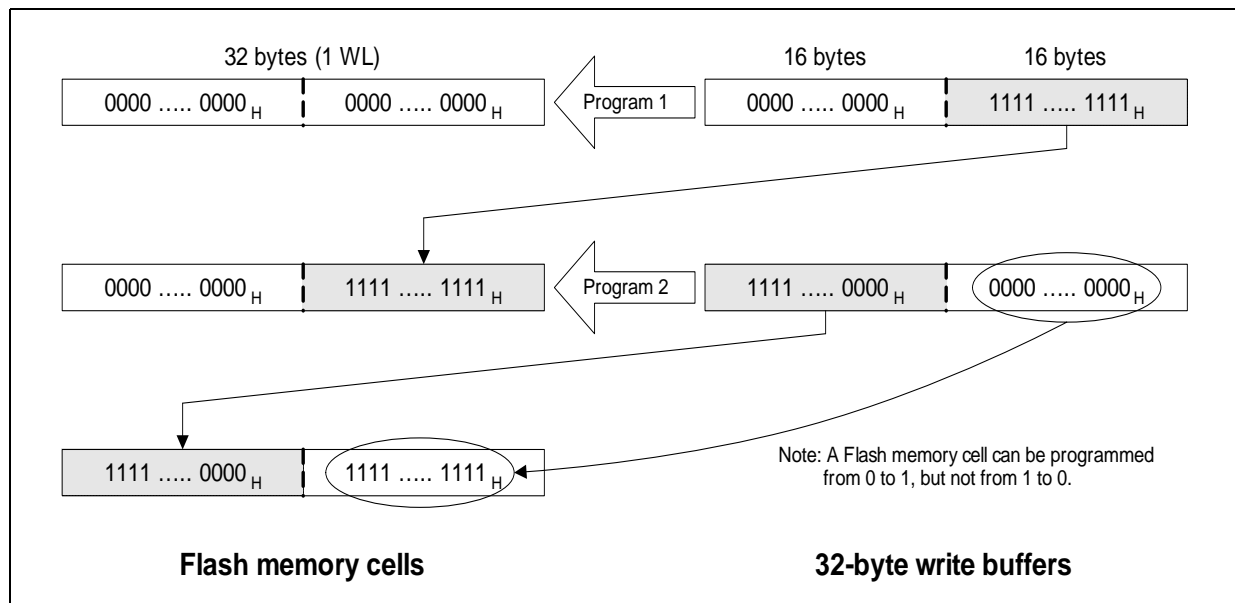

Figure 11 D-Flash Programming

Note: When programming a D-Flash WL the second time, the previously programmed Flash memory cells (whether 0s or 1s) should be reprogrammed with 0s to retain its original contents and to prevent “over-programming”.

3.4 Interrupt System

The XC800 Core supports one non-maskable interrupt (NMI) and 14 maskable interrupt requests. In addition to the standard interrupt functions supported by the core, e.g., configurable interrupt priority and interrupt masking, the SAA-XC886 interrupt system provides extended interrupt support capabilities such as the mapping of each interrupt vector to several interrupt sources to increase the number of interrupt sources supported, and additional status registers for detecting and determining the interrupt source.

3.4.1 Interrupt Source

Figure 12 to Figure 16 give a general overview of the interrupt sources and nodes, and their corresponding control and status flags.

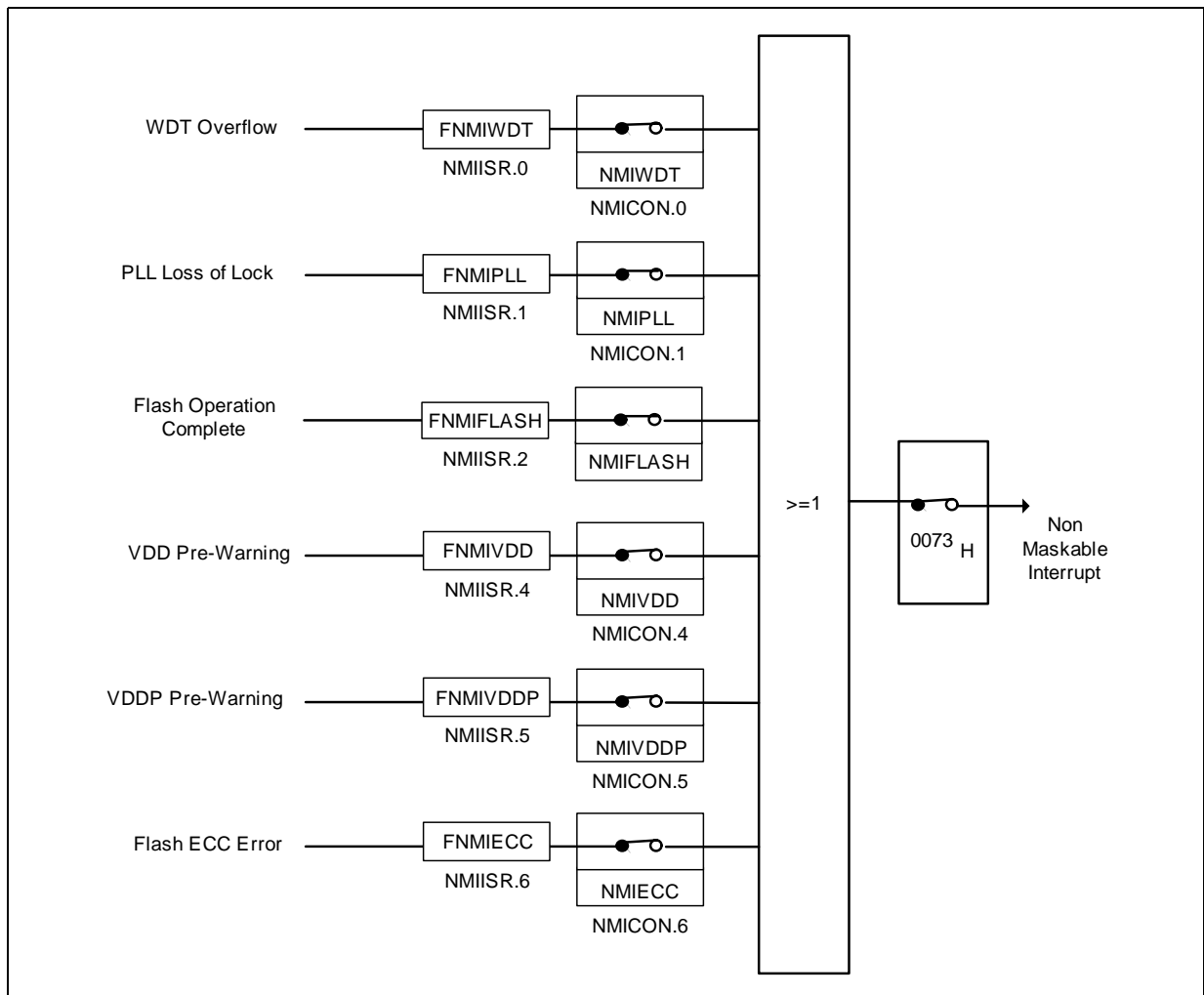

Figure 12 Non-Maskable Interrupt Request Sources

Functional Description

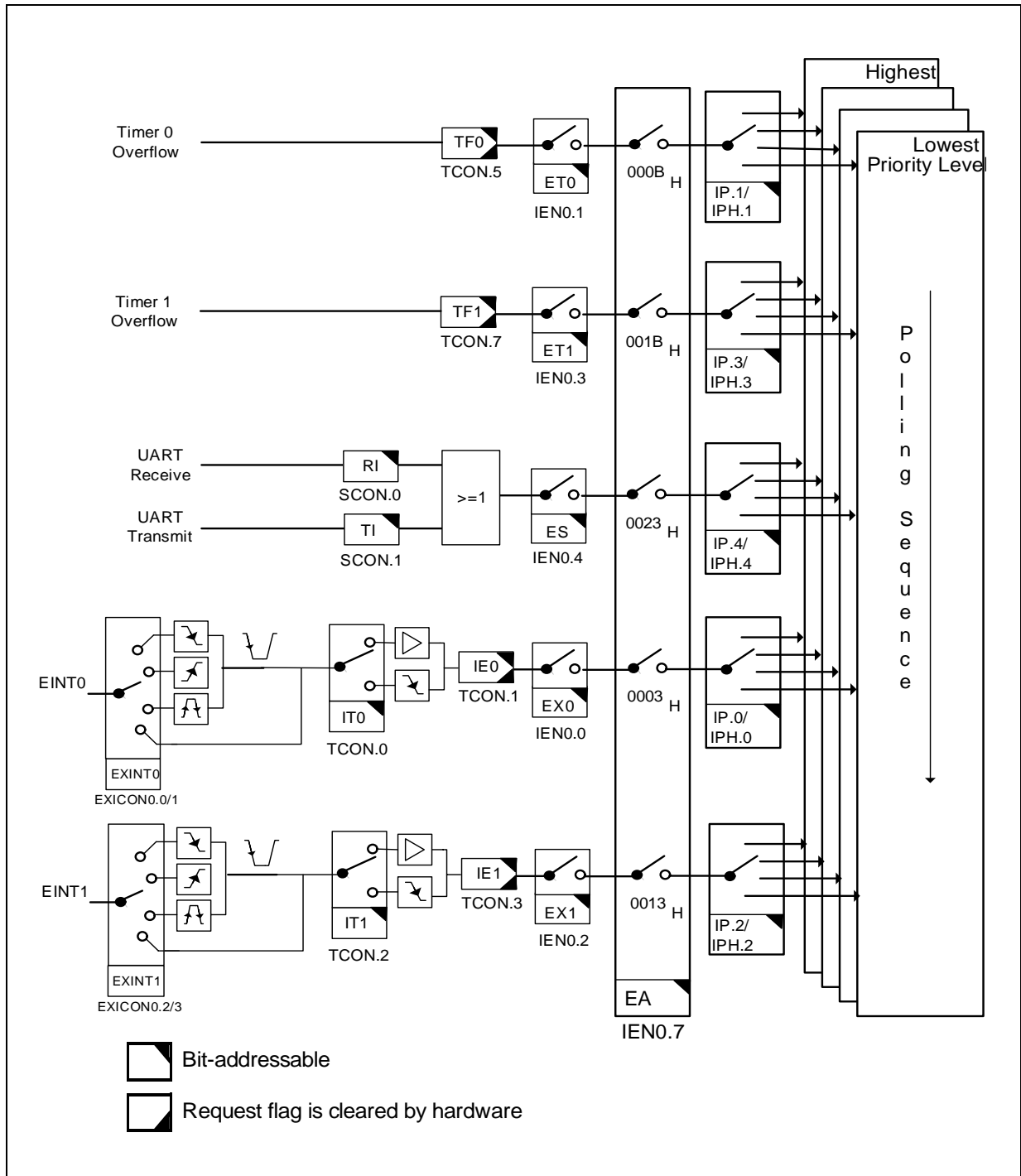

Figure 13 Interrupt Request Sources (Part 1)

Functional Description

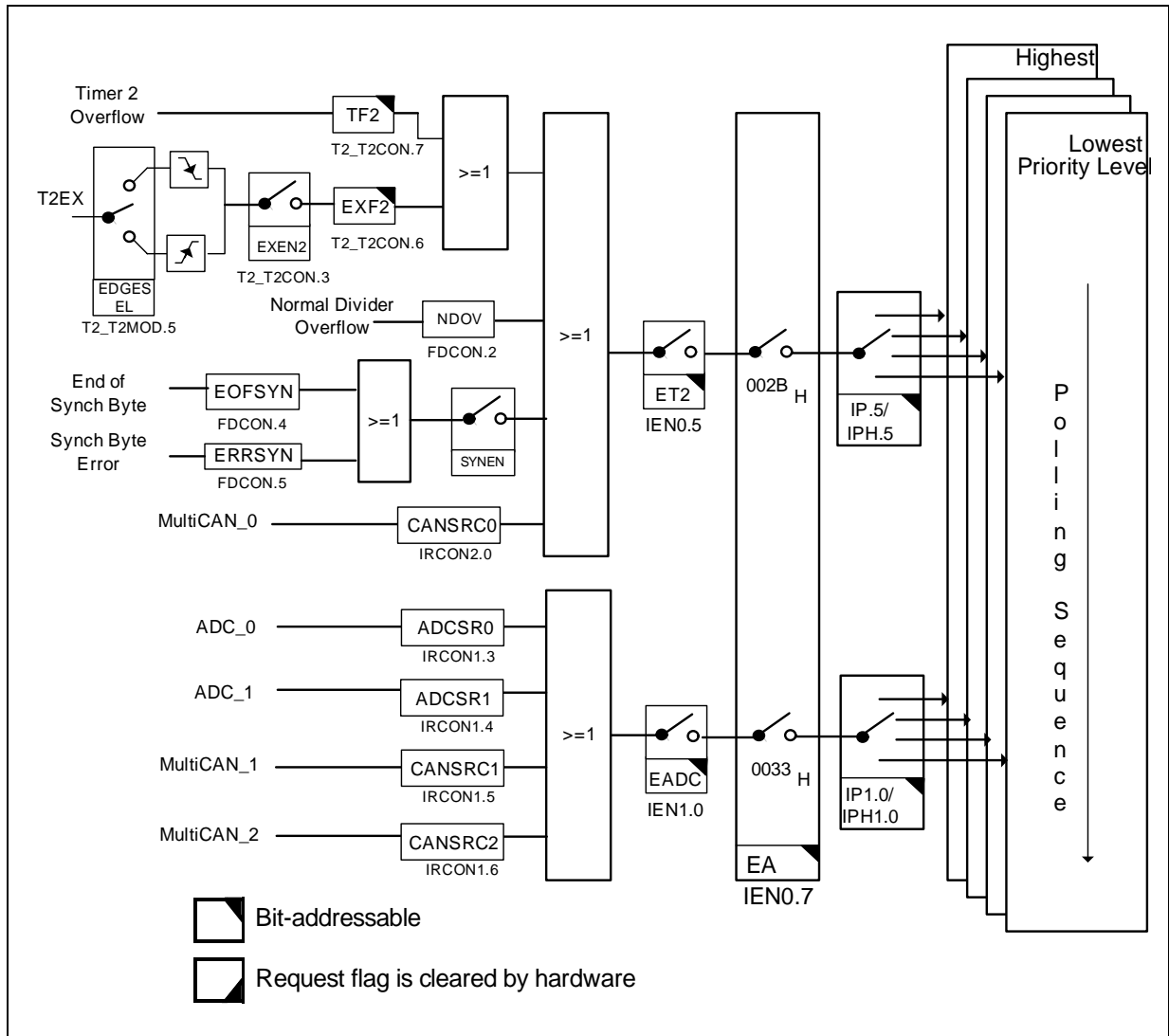

Figure 14 Interrupt Request Sources (Part 2)

Functional Description

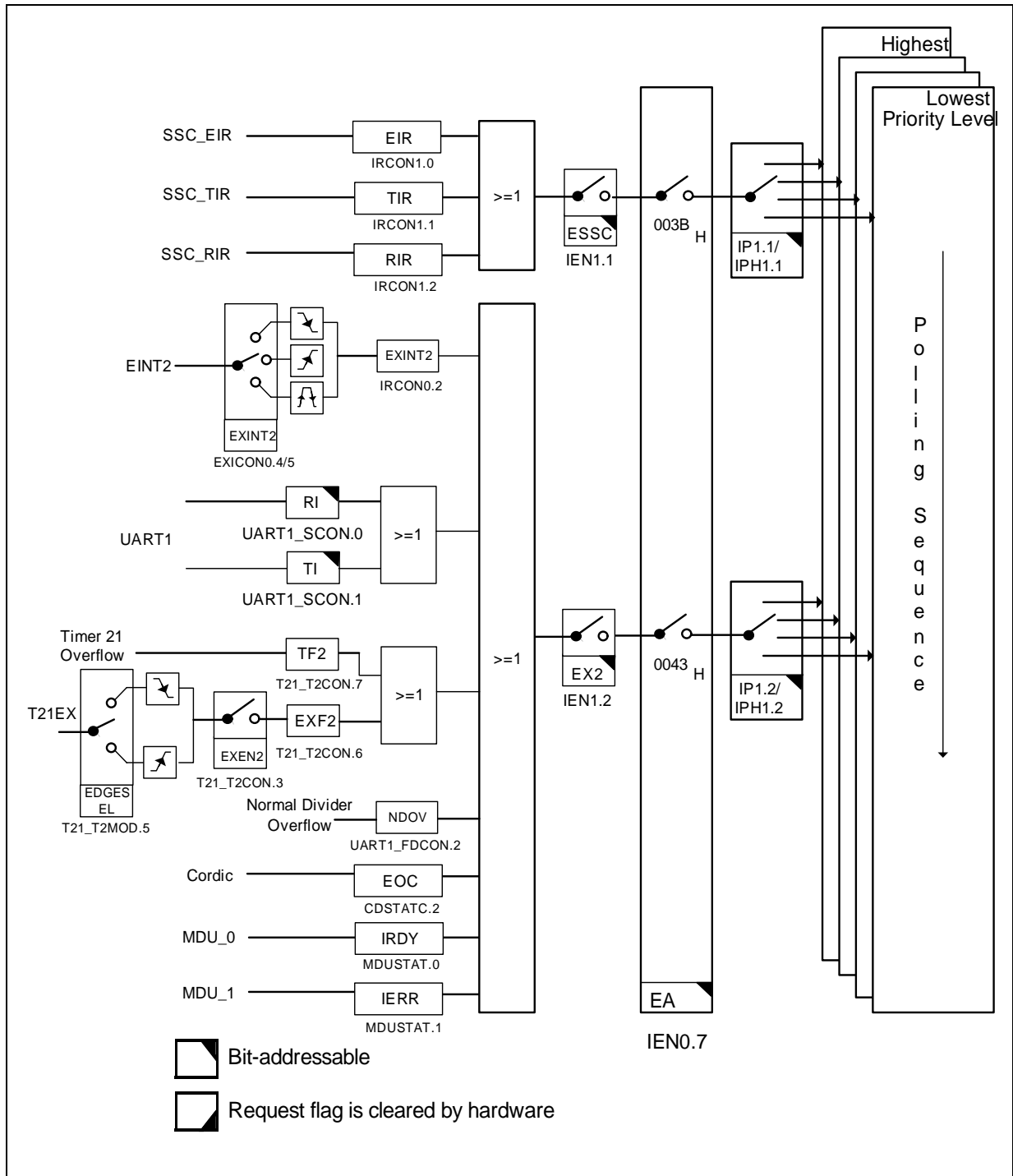

Figure 15 Interrupt Request Sources (Part 3)

Functional Description

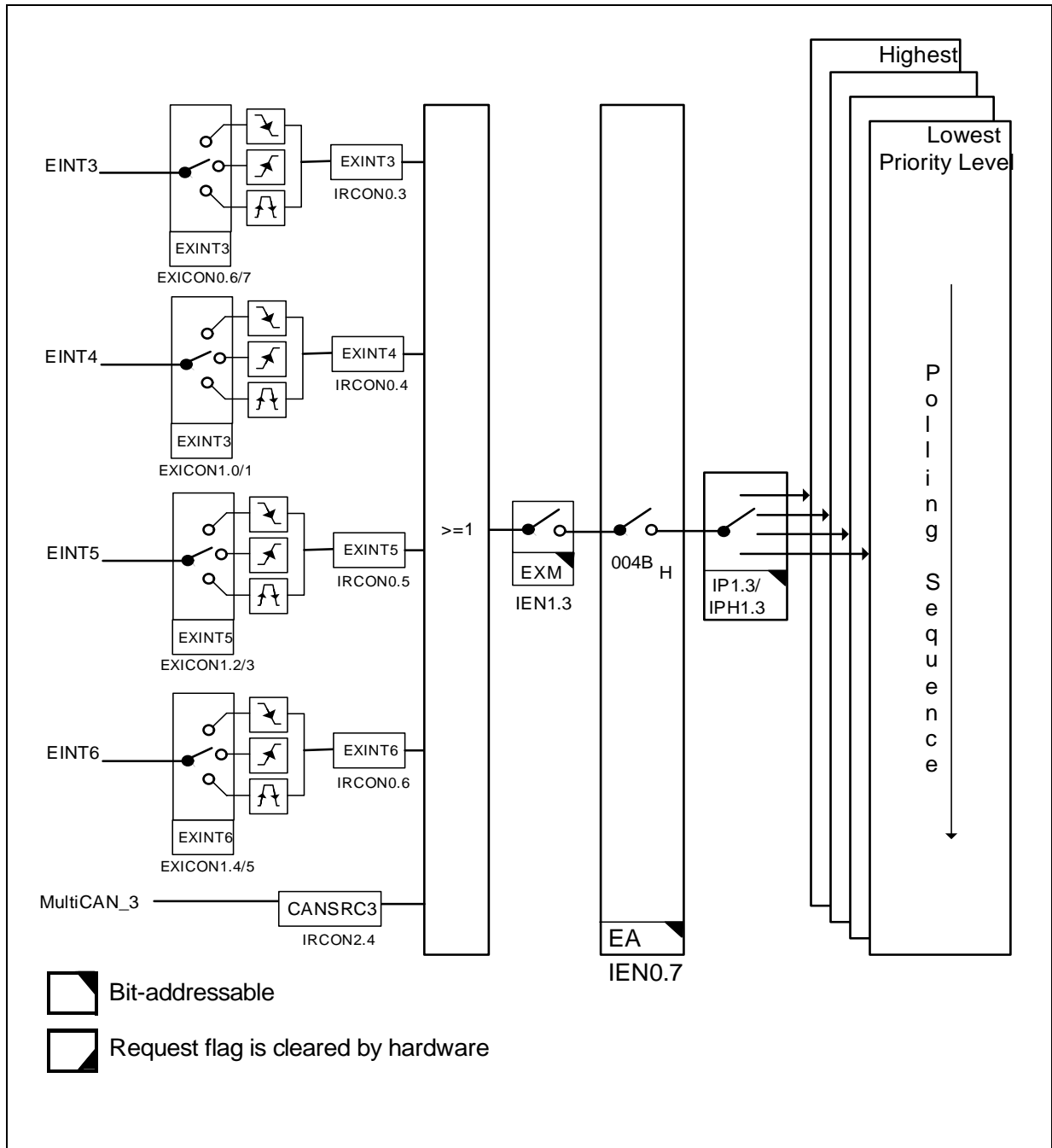

Figure 16 Interrupt Request Sources (Part 4)

Functional Description

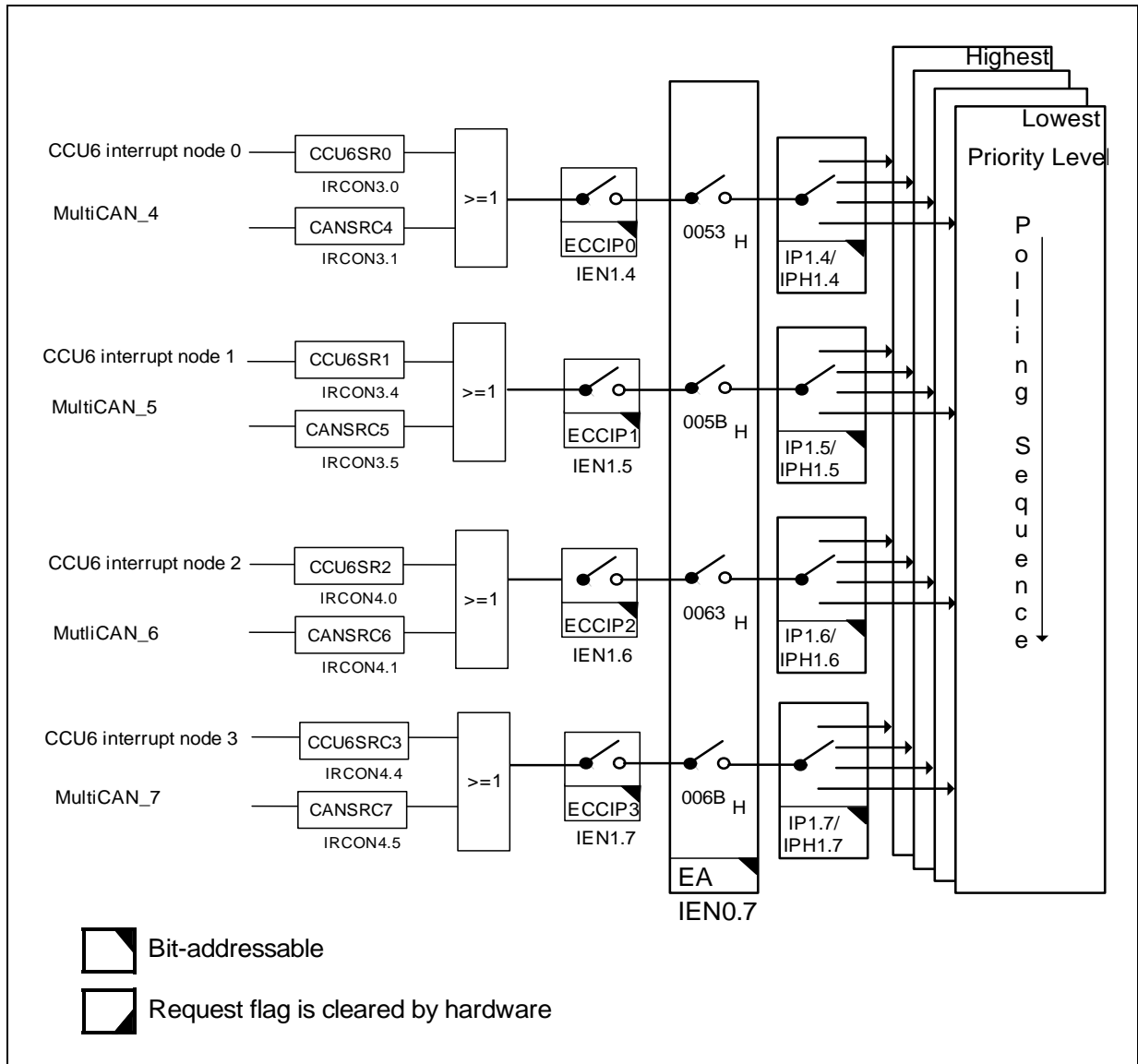

Figure 17 Interrupt Request Sources (Part 5)

3.4.2 Interrupt Source and Vector

Each interrupt event source has an associated interrupt vector address for the interrupt node it belongs to. This vector is accessed to service the corresponding interrupt node request. The interrupt service of each interrupt source can be individually enabled or disabled via an enable bit. The assignment of the SAA-XC886 interrupt sources to the interrupt vector address and the corresponding interrupt node enable bits are summarized in [Table 19](#).

Table 19 Interrupt Vector Addresses

Interrupt Source	Vector Address	Assignment for SAA-XC886	Enable Bit	SFR
NMI	0073 _H	Watchdog Timer NMI	NMIWDT	NMICON
		PLL NMI	NMIPLL	
		Flash NMI	NMIFLASH	
		VDDC Prewarning NMI	NMIVDD	
		VDDP Prewarning NMI	NMIVDDP	
		Flash ECC NMI	NMIECC	
XINTR0	0003 _H	External Interrupt 0	EX0	IEN0
XINTR1	000B _H	Timer 0	ET0	
XINTR2	0013 _H	External Interrupt 1	EX1	
XINTR3	001B _H	Timer 1	ET1	
XINTR4	0023 _H	UART	ES	
XINTR5	002B _H	T2	ET2	
		UART Fractional Divider (Normal Divider Overflow)		
		MultiCAN Node 0		
		LIN		

Functional Description
Table 19 Interrupt Vector Addresses (cont'd)

Interrupt Source	Vector Address	Assignment for SAA-XC886	Enable Bit	SFR
XINTR6	0033 _H	MultiCAN Nodes 1 and 2	EADC	IEN1
		ADC[1:0]		
XINTR7	003B _H	SSC	ESSC	
XINTR8	0043 _H	External Interrupt 2	EX2	
		T21		
		CORDIC		
		UART1		
		UART1 Fractional Divider (Normal Divider Overflow)		
		MDU[1:0]		
XINTR9	004B _H	External Interrupt 3	EXM	
		External Interrupt 4		
		External Interrupt 5		
		External Interrupt 6		
		MultiCAN Node 3		
XINTR10	0053 _H	CCU6 INP0	ECCIP0	
		MultiCAN Node 4		
XINTR11	005B _H	CCU6 INP1	ECCIP1	
		MultiCAN Node 5		
XINTR12	0063 _H	CCU6 INP2	ECCIP2	
		MultiCAN Node 6		
XINTR13	006B _H	CCU6 INP3	ECCIP3	
		MultiCAN Node 7		

3.4.3 Interrupt Priority

An interrupt that is currently being serviced can only be interrupted by a higher-priority interrupt, but not by another interrupt of the same or lower priority. Hence, an interrupt of the highest priority cannot be interrupted by any other interrupt request.

If two or more requests of different priority levels are received simultaneously, the request of the highest priority is serviced first. If requests of the same priority are received simultaneously, then an internal polling sequence determines which request is serviced first. Thus, within each priority level, there is a second priority structure determined by the polling sequence shown in [Table 20](#).

Table 20 Priority Structure within Interrupt Level

Source	Level
Non-Maskable Interrupt (NMI)	(highest)
External Interrupt 0	1
Timer 0 Interrupt	2
External Interrupt 1	3
Timer 1 Interrupt	4
UART Interrupt	5
Timer 2, UART Normal Divider Overflow, MultiCAN, LIN Interrupt	6
ADC, MultiCAN Interrupt	7
SSC Interrupt	8
External Interrupt 2, Timer 21, UART1, UART1 Normal Divider Overflow, MDU, CORDIC Interrupt	9
External Interrupt [6:3], MultiCAN Interrupt	10
CCU6 Interrupt Node Pointer 0, MultiCAN interrupt	11
CCU6 Interrupt Node Pointer 1, MultiCAN Interrupt	12
CCU6 Interrupt Node Pointer 2, MultiCAN Interrupt	13
CCU6 Interrupt Node Pointer 3, MultiCAN Interrupt	14

3.5 Parallel Ports

The SAA-XC886 has 34 port pins organized into five parallel ports, Port 0 (P0) to Port 4 (P4). Each pin has a pair of internal pull-up and pull-down devices that can be individually enabled or disabled. Ports P0, P1, P3 and P4 are bidirectional and can be used as general purpose input/output (GPIO) or to perform alternate input/output functions for the on-chip peripherals. When configured as an output, the open drain mode can be selected. Port P2 is an input-only port, providing general purpose input functions, alternate input functions for the on-chip peripherals, and also analog inputs for the Analog-to-Digital Converter (ADC).

Bidirectional Port Features

- Configurable pin direction
- Configurable pull-up/pull-down devices
- Configurable open drain mode
- Transfer of data through digital inputs and outputs (general purpose I/O)
- Alternate input/output for on-chip peripherals

Input Port Features

- Configurable input driver
- Configurable pull-up/pull-down devices
- Receive of data through digital input (general purpose input)
- Alternate input for on-chip peripherals
- Analog input for ADC module

Figure 18 shows the structure of a bidirectional port pin.

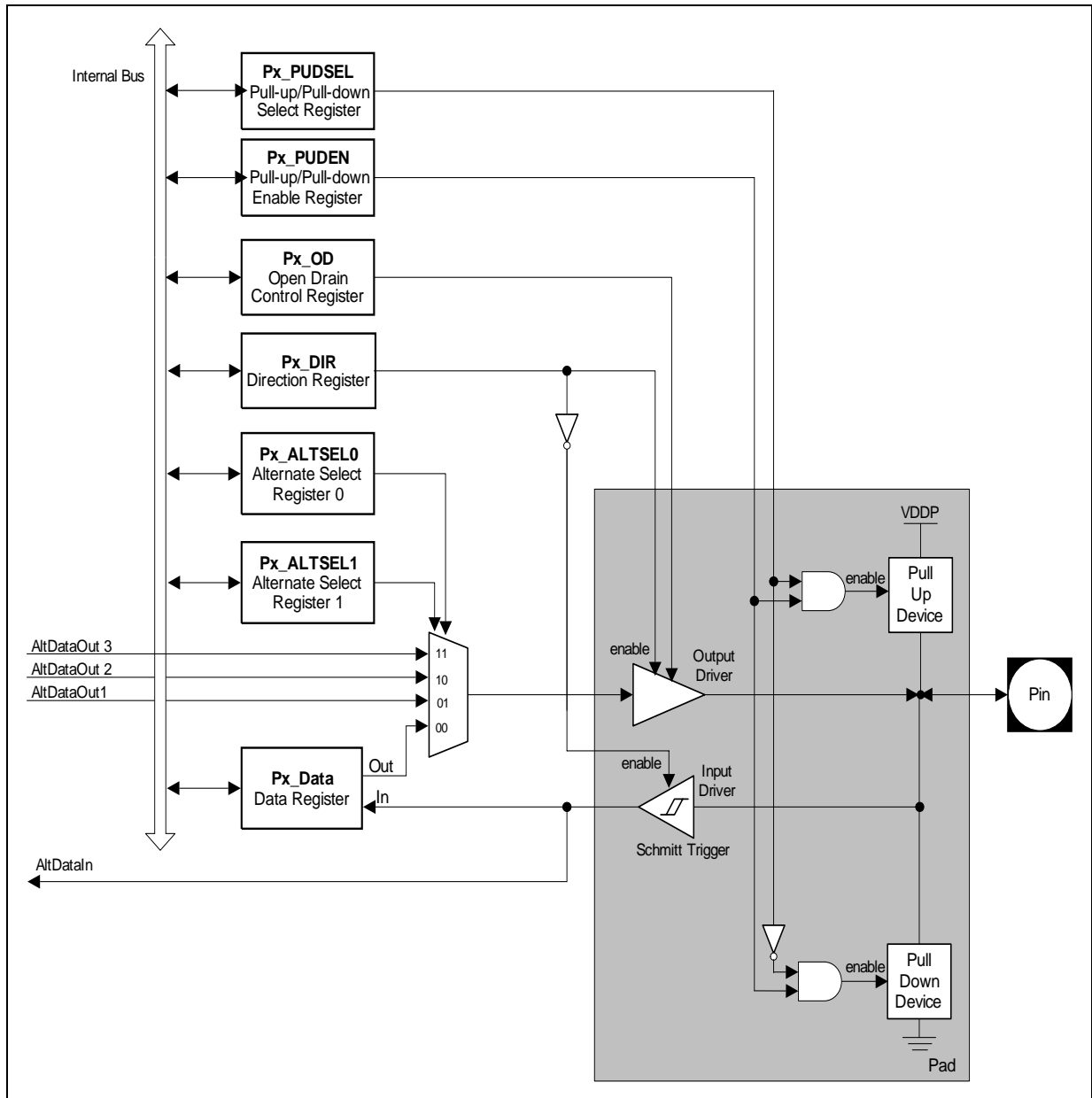

Figure 18 General Structure of Bidirectional Port

Figure 19 shows the structure of an input-only port pin.

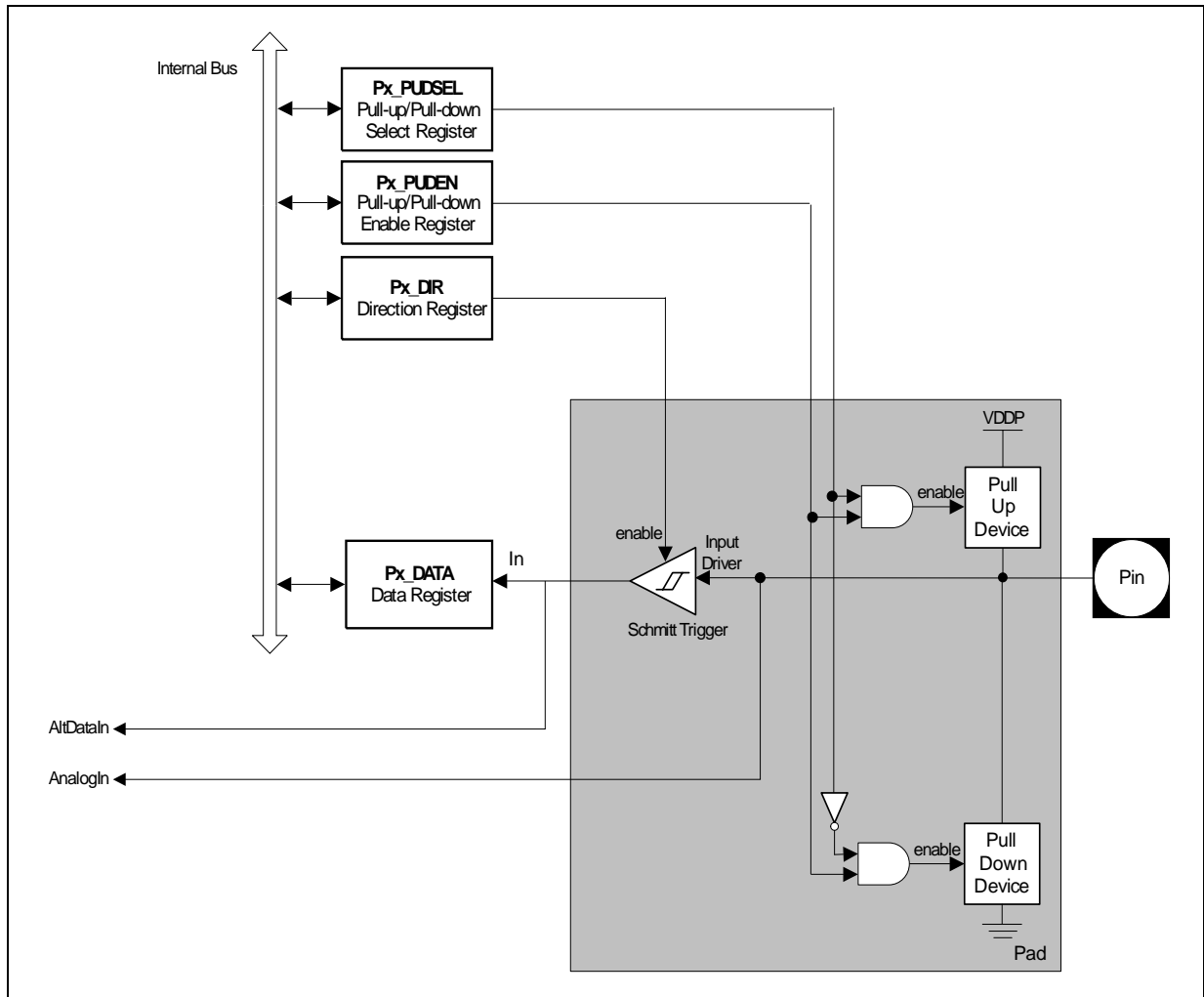

Figure 19 General Structure of Input Port

3.6 Power Supply System with Embedded Voltage Regulator

The SAA-XC886 microcontroller requires two different levels of power supply:

- 5.0 V for the Embedded Voltage Regulator (EVR) and Ports
- 2.5 V for the core, memory, on-chip oscillator, and peripherals

Figure 20 shows the SAA-XC886 power supply system. A power supply of 5.0 V must be provided from the external power supply pin. The 2.5 V power supply for the logic is generated by the EVR. The EVR helps to reduce the power consumption of the whole chip and the complexity of the application board design.

The EVR consists of a main voltage regulator and a low power voltage regulator. In active mode, both voltage regulators are enabled. In power-down mode, the main voltage regulator is switched off, while the low power voltage regulator continues to function and provide power supply to the system with low power consumption.

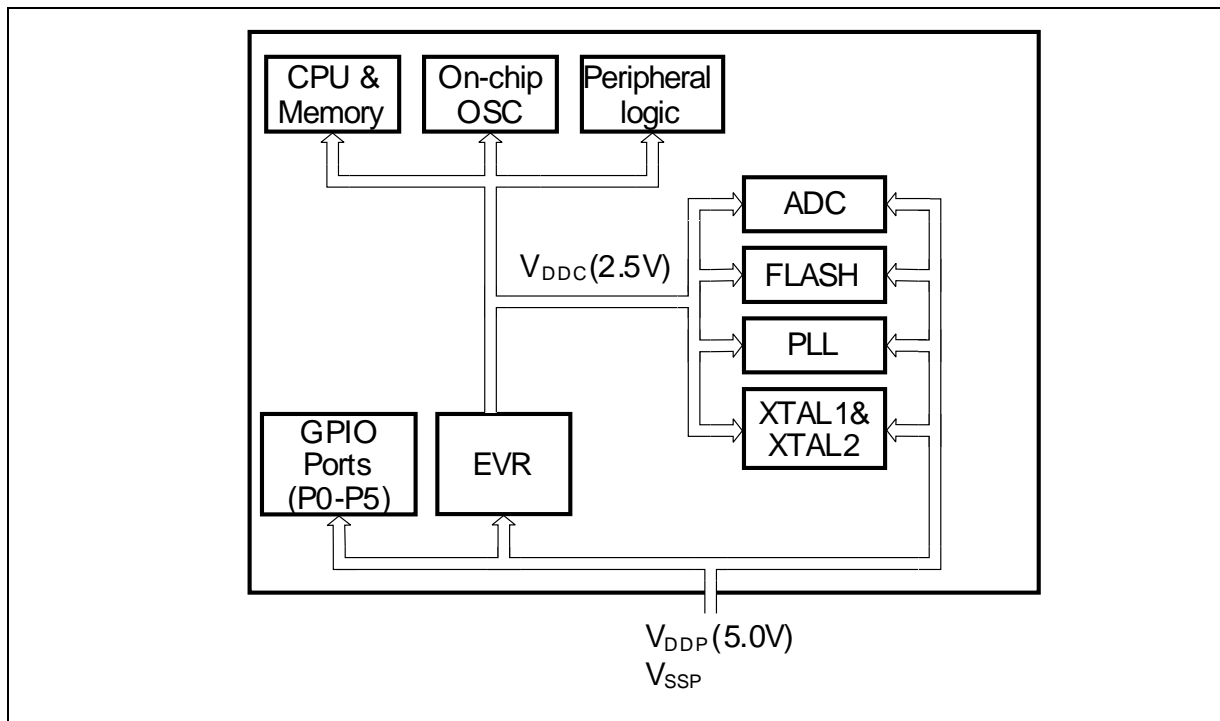

Figure 20 SAA-XC886 Power Supply System

EVR Features

- Input voltage (V_{DDP}): 5.0 V
- Output voltage (V_{DDC}): 2.5 V \pm 7.5%
- Low power voltage regulator provided in power-down mode
- V_{DDC} and V_{DDP} prewarning detection
- V_{DDC} brownout detection

3.7 Reset Control

The SAA-XC886 has five types of reset: power-on reset, hardware reset, watchdog timer reset, power-down wake-up reset, and brownout reset.

When the SAA-XC886 is first powered up, the status of certain pins (see [Table 22](#)) must be defined to ensure proper start operation of the device. At the end of a reset sequence, the sampled values are latched to select the desired boot option, which cannot be modified until the next power-on reset or hardware reset. This guarantees stable conditions during the normal operation of the device.

In order to power up the system properly, the external reset pin $\overline{\text{RESET}}$ must be asserted until V_{DDC} reaches $0.9 \cdot V_{\text{DDC}}$. The delay of external reset can be realized by an external capacitor at RESET pin. This capacitor value must be selected so that V_{RESET} reaches 0.4 V, but not before V_{DDC} reaches $0.9 \cdot V_{\text{DDC}}$.

A typical application example is shown in [Figure 21](#). The V_{DDP} capacitor value is 100 nF while the V_{DDC} capacitor value is 220 nF. The capacitor connected to $\overline{\text{RESET}}$ pin is 100 nF.

Typically, the time taken for V_{DDC} to reach $0.9 \cdot V_{\text{DDC}}$ is less than $50 \mu\text{s}$ once V_{DDP} reaches 2.3V. Hence, based on the condition that 10% to 90% V_{DDP} (slew rate) is less than $500 \mu\text{s}$, the $\overline{\text{RESET}}$ pin should be held low for $500 \mu\text{s}$ typically. See [Figure 22](#).

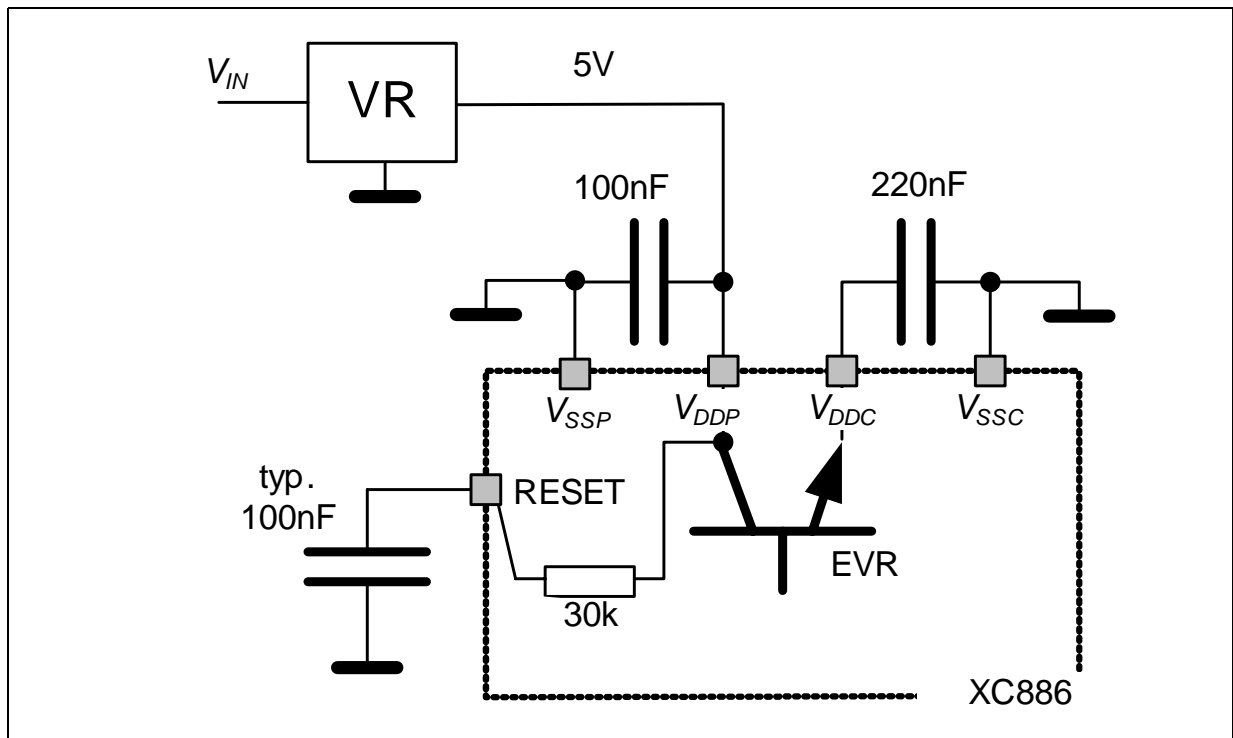

Figure 21 Reset Circuitry

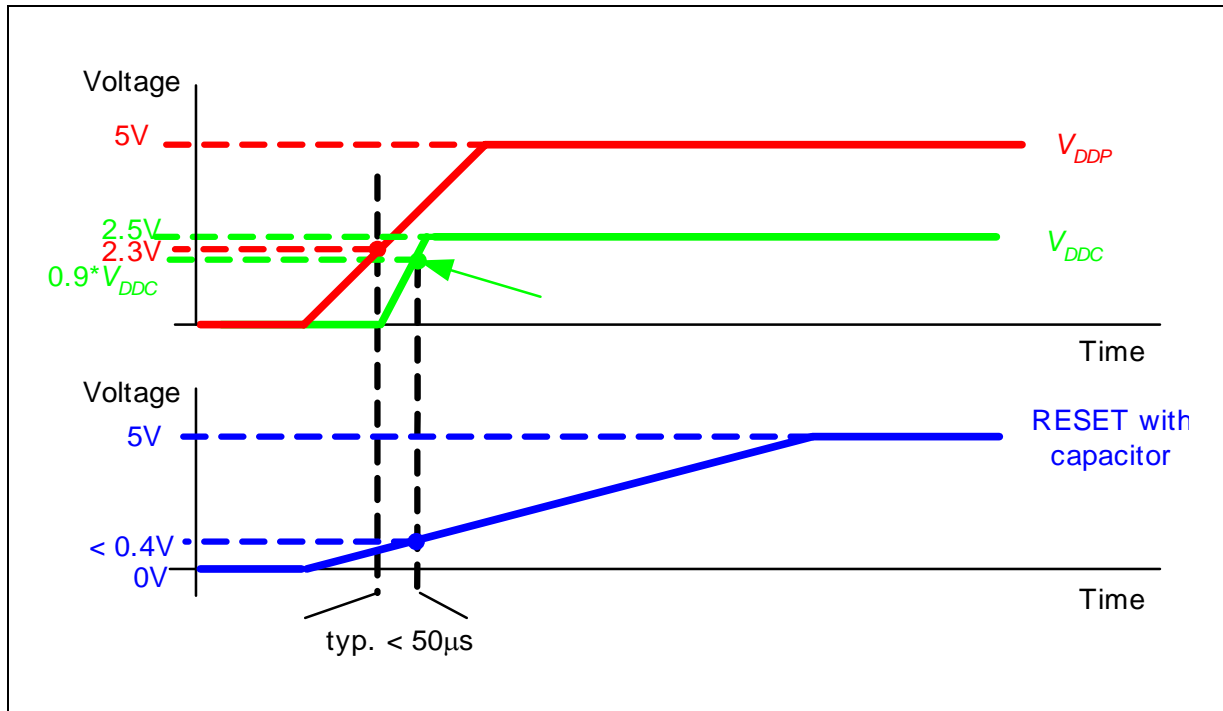

Figure 22 V_{DDP} , V_{DDC} and V_{RESET} during Power-on Reset

The second type of reset in SAA-XC886 is the hardware reset. This reset function can be used during normal operation or when the chip is in power-down mode. A reset input pin \overline{RESET} is provided for the hardware reset.

The Watchdog Timer (WDT) module is also capable of resetting the device if it detects a malfunction in the system.

Another type of reset that needs to be detected is a reset while the device is in power-down mode (wake-up reset). While the contents of the static RAM are undefined after a power-on reset, they are well defined after a wake-up reset from power-down mode.

3.7.1 Module Reset Behavior

Table 21 lists the functions of the SAA-XC886 and the various reset types that affect these functions. The symbol “■” signifies that the particular function is reset to its default state.

Table 21 Effect of Reset on Device Functions

Module/ Function	Wake-Up Reset	Watchdog Reset	Hardware Reset	Power-On Reset	Brownout Reset
CPU Core	■	■	■	■	■
Peripherals	■	■	■	■	■
On-Chip Static RAM	Not affected, Reliable	Not affected, Reliable	Not affected, Reliable	Affected, un- reliable	Affected, un- reliable
Oscillator, PLL	■	Not affected	■	■	■
Port Pins	■	■	■	■	■
EVR	The voltage regulator is switched on	Not affected	■	■	■
FLASH	■	■	■	■	■
NMI	Disabled	Disabled	■	■	■

3.7.2 Booting Scheme

When the SAA-XC886 is reset, it must identify the type of configuration with which to start the different modes once the reset sequence is complete. Thus, boot configuration information that is required for activation of special modes and conditions needs to be applied by the external world through input pins. After power-on reset or hardware reset, the pins MBC, TMS and P0.0 collectively select the different boot options. **Table 22** shows the available boot options in the SAA-XC886.

Table 22 SAA-XC886 Boot Selection

MBC	TMS	P0.0	Type of Mode	PC Start Value
1	0	X	User Mode ¹⁾ ; on-chip OSC/PLL non-bypassed	0000 _H
0	0	X	BSL Mode; on-chip OSC/PLL non-bypassed ²⁾	0000 _H
0	1	0	OCDS Mode; on-chip OSC/PLL non-bypassed	0000 _H
1	1	0	User (JTAG) Mode ³⁾ ; on-chip OSC/PLL non-bypassed (normal)	0000 _H

Functional Description

- 1) BSL mode is automatically entered if no valid password is installed and data at memory address 0000H equals zero.
- 2) OSC is bypassed in MultiCAN BSL mode
- 3) Normal user mode with standard JTAG (TCK,TDI,TDO) pins for hot-attach purpose.

Note: The boot options are valid only with the default set of UART and JTAG pins.

3.8 Clock Generation Unit

The Clock Generation Unit (CGU) allows great flexibility in the clock generation for the SAA-XC886. The power consumption is indirectly proportional to the frequency, whereas the performance of the microcontroller is directly proportional to the frequency. During user program execution, the frequency can be programmed for an optimal ratio between performance and power consumption. Therefore the power consumption can be adapted to the actual application state.

Features

- Phase-Locked Loop (PLL) for multiplying clock source by different factors
- PLL Base Mode
- Prescaler Mode
- PLL Mode
- Power-down mode support

The CGU consists of an oscillator circuit and a PLL. In the SAA-XC886, the oscillator can be from either of these two sources: the on-chip oscillator (9.6 MHz) or the external oscillator (4 MHz to 12 MHz). The term “oscillator” is used to refer to both on-chip oscillator and external oscillator, unless otherwise stated. After the reset, the on-chip oscillator will be used by default. The external oscillator can be selected via software. In addition, the PLL provides a fail-safe logic to perform oscillator run and loss-of-lock detection. This allows emergency routines to be executed for system recovery or to perform system shut down.

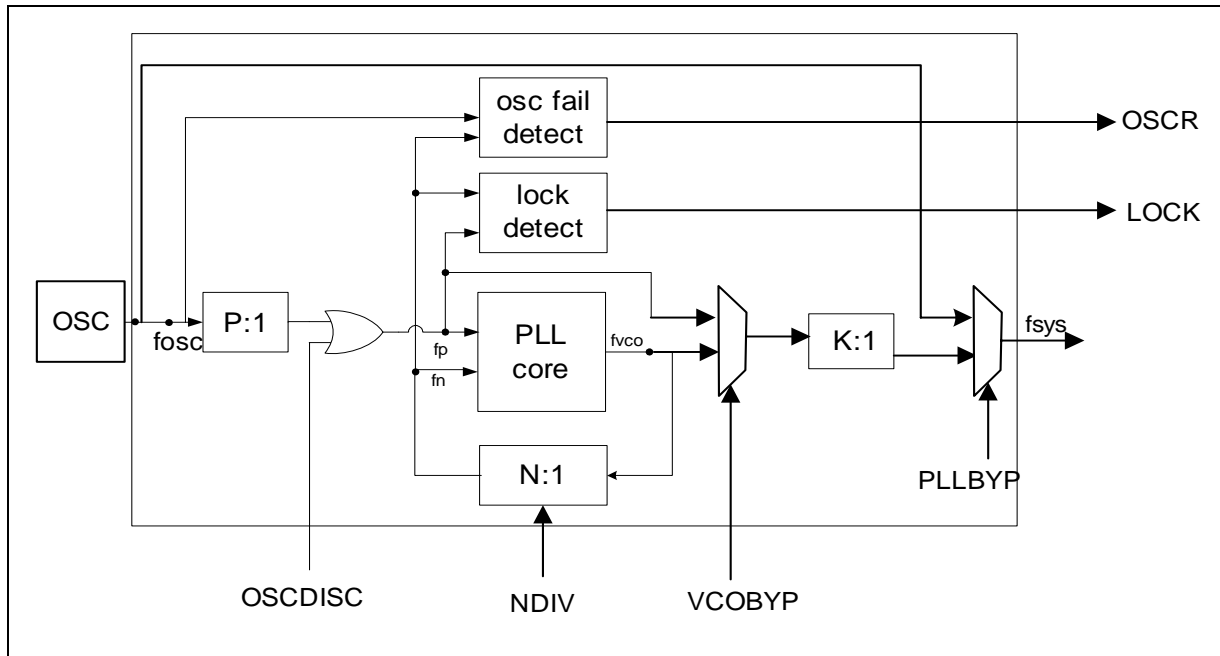

Figure 23 CGU Block Diagram

PLL Base Mode

When the oscillator is disconnected from the PLL, the system clock is derived from the VCO base (free running) frequency clock ([Table 24](#)) divided by the K factor.

$$f_{SYS} = f_{VCObase} \times \frac{1}{K} \tag{3.1}$$

Prescaler Mode (VCO Bypass Operation)

In VCO bypass operation, the system clock is derived from the oscillator clock, divided by the P and K factors.

$$f_{SYS} = f_{OSC} \times \frac{1}{P \times K} \tag{3.2}$$

Functional Description
PLL Mode

The system clock is derived from the oscillator clock, multiplied by the N factor, and divided by the P and K factors. Both VCO bypass and PLL bypass must be inactive for this PLL mode. The PLL mode is used during normal system operation.

$$f_{\text{SYS}} = f_{\text{OSC}} \times \frac{N}{P \times K}$$

(3.3)

System Frequency Selection

For the SAA-XC886, the value of P is fixed to 1. In order to obtain the required f_{sys} , the value of N and K can be selected by bits NDIV and KDIV respectively for different oscillator inputs. The output frequency must always be configured for 96 MHz. **Table 23** provides examples on how $f_{\text{sys}} = 96$ MHz can be obtained for the different oscillator sources.

Table 23 System frequency ($f_{\text{sys}} = 96$ MHz)

Oscillator	Fosc	N	P	K	Fsys
On-chip	9.6 MHz	20	1	2	96 MHz
External	8 MHz	24	1	2	96 MHz
	6 MHz	32	1	2	96 MHz
	4 MHz	48	1	2	96 MHz

Table 24 shows the VCO range for the SAA-XC886.

Table 24 VCO Range

f_{VCOmin}	f_{VCOmax}	$f_{VCOFREEmin}$	$f_{VCOFREEmax}$	Unit
150	200	20	80	MHz
100	150	10	80	MHz

3.8.1 Recommended External Oscillator Circuits

The oscillator circuit, a Pierce oscillator, is designed to work with both, an external crystal oscillator or an external stable clock source. It basically consists of an inverting amplifier and a feedback element with XTAL1 as input, and XTAL2 as output.

When using a crystal, a proper external oscillator circuitry must be connected to both pins, XTAL1 and XTAL2. The crystal frequency can be within the range of 4 MHz to 12 MHz. Additionally, it is necessary to have two load capacitances C_{X1} and C_{X2} , and depending on the crystal type, a series resistor R_{X2} , to limit the current. A test resistor R_Q may be temporarily inserted to measure the oscillation allowance (negative resistance) of the oscillator circuitry. R_Q values are typically specified by the crystal vendor. The C_{X1} and C_{X2} values shown in **Figure 24** can be used as starting points for the negative resistance evaluation and for non-productive systems. The exact values and related operating range are dependent on the crystal frequency and have to be determined and optimized together with the crystal vendor using the negative resistance method. Oscillation measurement with the final target system is strongly recommended to verify the input amplitude at XTAL1 and to determine the actual oscillation allowance (margin negative resistance) for the oscillator-crystal system.

When using an external clock signal, the signal must be connected to XTAL1. XTAL2 is left open (unconnected).

The oscillator can also be used in combination with a ceramic resonator. The final circuitry must also be verified by the resonator vendor. **Figure 24** shows the recommended external oscillator circuitries for both operating modes, external crystal mode and external input clock mode.

Functional Description

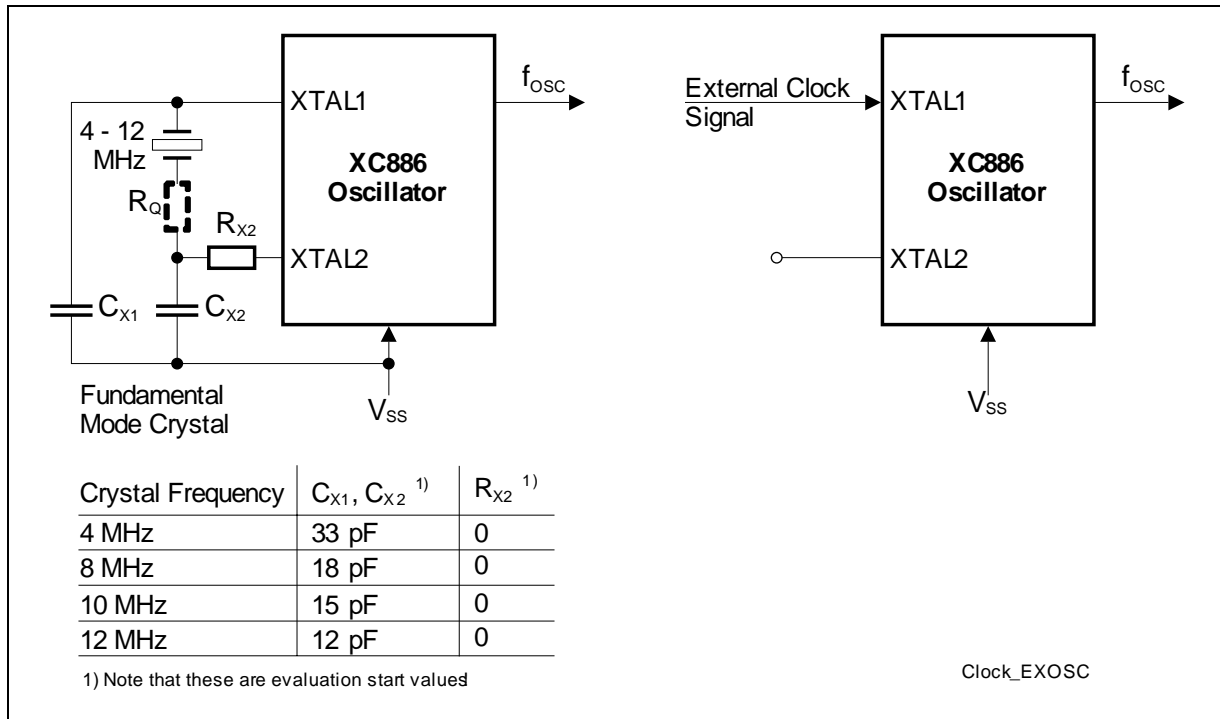

Figure 24 External Oscillator Circuitry

Note: For crystal operation, it is strongly recommended to measure the negative resistance in the final target system (layout) to determine the optimum parameters for the oscillator operation. Please refer to the minimum and maximum values of the negative resistance specified by the crystal supplier.

3.8.2 Clock Management

The CGU generates all clock signals required within the microcontroller from a single clock, f_{sys} . During normal system operation, the typical frequencies of the different modules are as follow:

- CPU clock: CCLK, SCLK = 24 MHz
- Fast clock (used by MultiCAN): FCLK = 24 or 48 MHz
- Peripheral clock: PCLK = 24 MHz
- Flash Interface clock: CCLK2 = 48 MHz and CCLK = 24 MHz

In addition, different clock frequencies can be output to pin CLKOUT (P0.0 or P0.7). The clock output frequency, which is derived from the clock output divider (bit COREL), can further be divided by 2 using toggle latch (bit TLEN is set to 1). The resulting output frequency has a 50% duty cycle. **Figure 25** shows the clock distribution of the SAA-XC886.

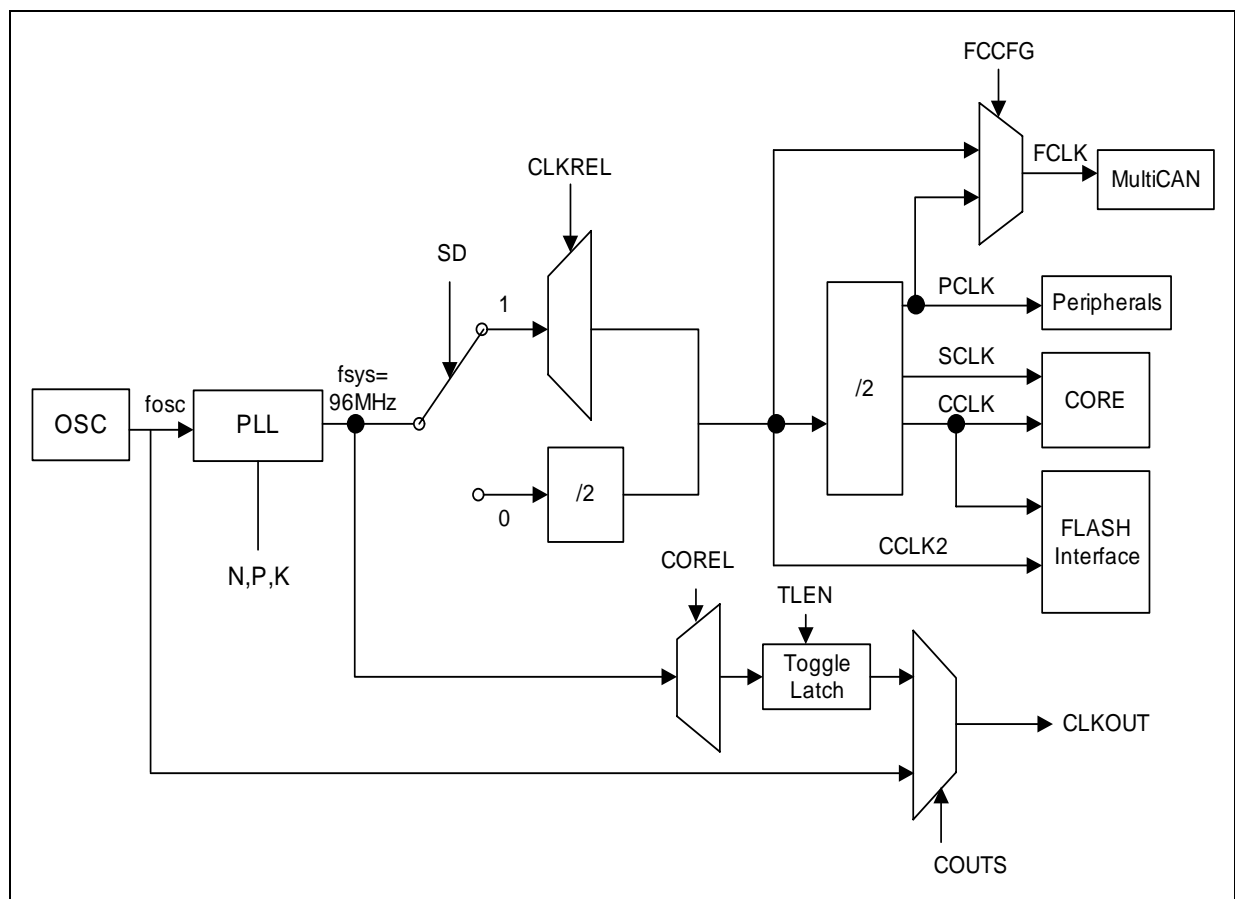

Figure 25 Clock Generation from f_{sys}

Functional Description

For power saving purposes, the clocks may be disabled or slowed down according to [Table 25](#).

Table 25 System frequency ($f_{\text{sys}} = 96 \text{ MHz}$)

Power Saving Mode	Action
Idle	Clock to the CPU is disabled.
Slow-down	Clocks to the CPU and all the peripherals are divided by a common programmable factor defined by bit field CMCON.CLKREL.
Power-down	Oscillator and PLL are switched off.

3.9 Power Saving Modes

The power saving modes of the SAA-XC886 provide flexible power consumption through a combination of techniques, including:

- Stopping the CPU clock
- Stopping the clocks of individual system components
- Reducing clock speed of some peripheral components
- Power-down of the entire system with fast restart capability

After a reset, the active mode (normal operating mode) is selected by default (see [Figure 26](#)) and the system runs in the main system clock frequency. From active mode, different power saving modes can be selected by software. They are:

- Idle mode
- Slow-down mode
- Power-down mode

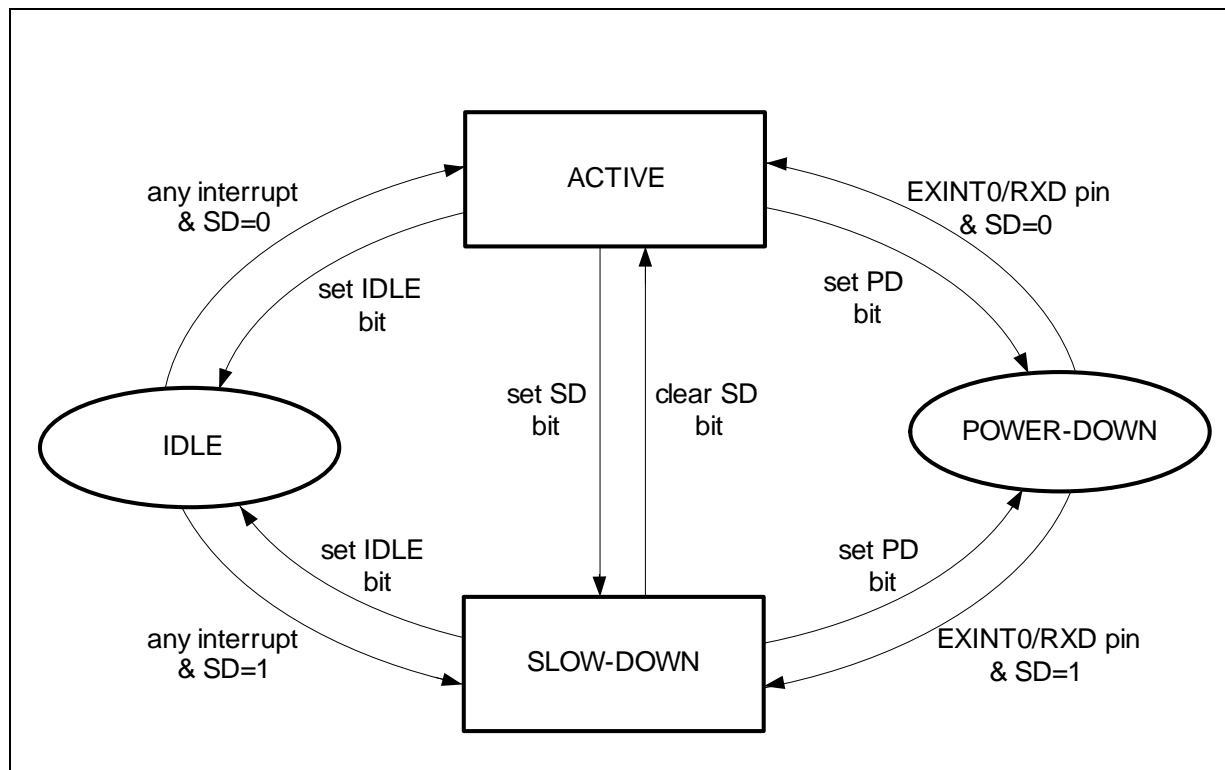

Figure 26 Transition between Power Saving Modes

Functional Description

3.10 Watchdog Timer

The Watchdog Timer (WDT) provides a highly reliable and secure way to detect and recover from software or hardware failures. The WDT is reset at a regular interval that is predefined by the user. The CPU must service the WDT within this interval to prevent the WDT from causing an SAA-XC886 system reset. Hence, routine service of the WDT confirms that the system is functioning properly. This ensures that an accidental malfunction of the SAA-XC886 will be aborted in a user-specified time period.

In debug mode, the WDT is default suspended and stops counting. Therefore, there is no need to refresh the WDT during debugging.

Features

- 16-bit Watchdog Timer
- Programmable reload value for upper 8 bits of timer
- Programmable window boundary
- Selectable input frequency of $f_{PCLK}/2$ or $f_{PCLK}/128$
- Time-out detection with NMI generation and reset prewarning activation (after which a system reset will be performed)

The WDT is a 16-bit timer incremented by a count rate of $f_{PCLK}/2$ or $f_{PCLK}/128$. This 16-bit timer is realized as two concatenated 8-bit timers. The upper 8 bits of the WDT can be preset to a user-programmable value via a watchdog service access in order to modify the watchdog expire time period. The lower 8 bits are reset on each service access.

Figure 27 shows the block diagram of the WDT unit.

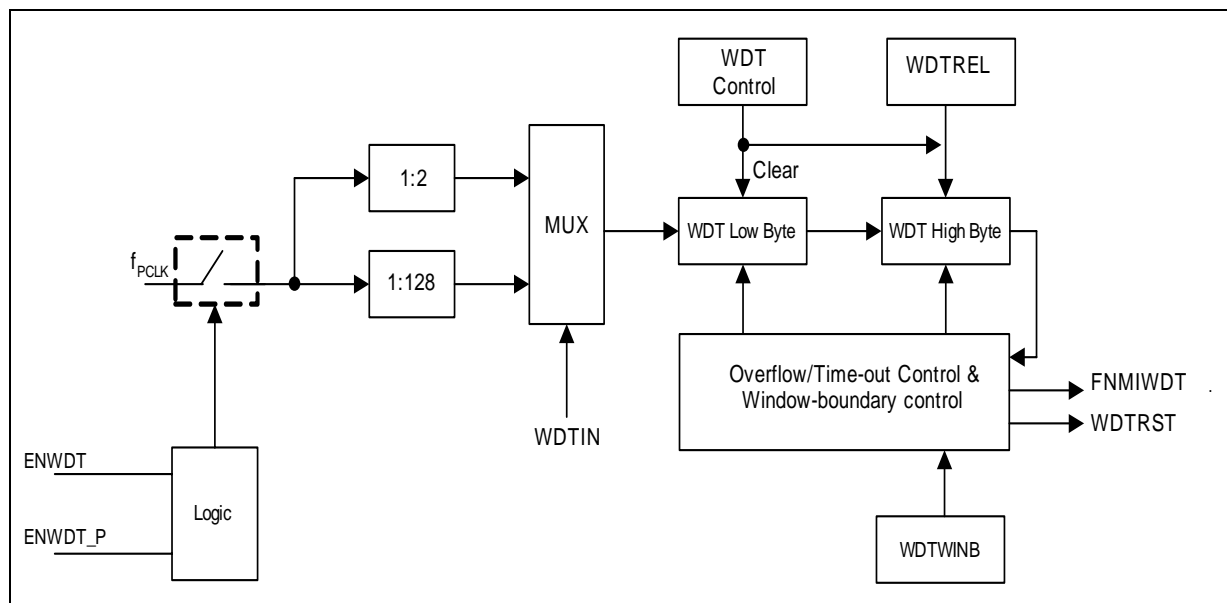

Figure 27 WDT Block Diagram

Functional Description

If the WDT is not serviced before the timer overflow, a system malfunction is assumed. As a result, the WDT NMI is triggered (assert FNMIWDT) and the reset prewarning is entered. The prewarning period lasts for 30_H count, after which the system is reset (assert WDTRST).

The WDT has a “programmable window boundary” which disallows any refresh during the WDT’s count-up. A refresh during this window boundary constitutes an invalid access to the WDT, causing the reset prewarning to be entered but without triggering the WDT NMI. The system will still be reset after the prewarning period is over. The window boundary is from 0000_H to the value obtained from the concatenation of WDTWINB and 00_H.

After being serviced, the WDT continues counting up from the value (<WDTREL> * 2⁸). The time period for an overflow of the WDT is programmable in two ways:

- The input frequency to the WDT can be selected to be either $f_{PCLK}/2$ or $f_{PCLK}/128$
- The reload value WDTREL for the high byte of WDT can be programmed in register WDTREL

The period, P_{WDT} , between servicing the WDT and the next overflow can be determined by the following formula:

$$P_{WDT} = \frac{2^{(1 + WDTIN \times 6)} \times (2^{16} - WDTREL \times 2^8)}{f_{PCLK}} \tag{3.4}$$

If the Window-Boundary Refresh feature of the WDT is enabled, the period P_{WDT} between servicing the WDT and the next overflow is shortened if WDTWINB is greater than WDTREL, see **Figure 28**. This period can be calculated using the same formula by replacing WDTREL with WDTWINB. For this feature to be useful, WDTWINB cannot be smaller than WDTREL.

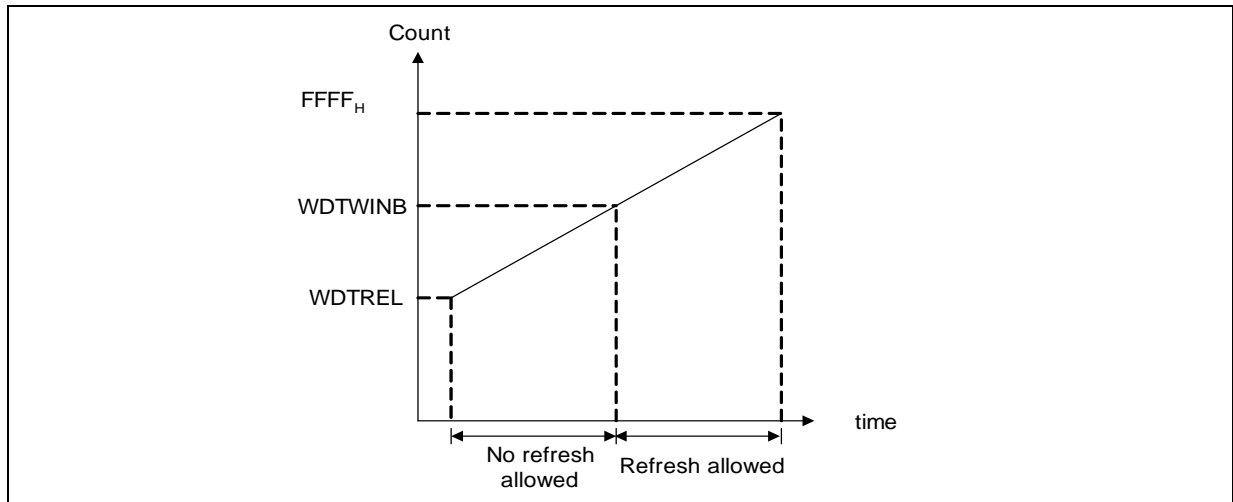

Figure 28 WDT Timing Diagram

Table 26 lists the possible watchdog time ranges that can be achieved using a certain module clock. Some numbers are rounded to 3 significant digits.

Table 26 Watchdog Time Ranges

Reload value In WDTREL	Prescaler for f_{PCLK}	
	2 (WDTIN = 0)	128 (WDTIN = 1)
	24 MHz	24 MHz
FF _H	21.3 μ s	1.37 ms
7F _H	2.75 ms	176 ms
00 _H	5.46 ms	350 ms

3.11 Multiplication/Division Unit

The Multiplication/Division Unit (MDU) provides fast 16-bit multiplication, 16-bit and 32-bit division as well as shift and normalize features. It has been integrated to support the SAA-XC886 Core in real-time control applications, which require fast mathematical computations.

Features

- Fast signed/unsigned 16-bit multiplication
- Fast signed/unsigned 32-bit divide by 16-bit and 16-bit divide by 16-bit operations
- 32-bit unsigned normalize operation
- 32-bit arithmetic/logical shift operations

Table 27 specifies the number of clock cycles used for calculation in various operations.

Table 27 MDU Operation Characteristics

Operation	Result	Remainder	No. of Clock Cycles used for calculation
Signed 32-bit/16-bit	32-bit	16-bit	33
Signed 16-bit/16bit	16-bit	16-bit	17
Signed 16-bit x 16-bit	32-bit	-	16
Unsigned 32-bit/16-bit	32-bit	16-bit	32
Unsigned 16-bit/16-bit	16-bit	16-bit	16
Unsigned 16-bit x 16-bit	32-bit	-	16
32-bit normalize	-	-	No. of shifts + 1 (Max. 32)
32-bit shift L/R	-	-	No. of shifts + 1 (Max. 32)

3.12 CORDIC Coprocessor

The CORDIC Coprocessor provides CPU with hardware support for the solving of circular (trigonometric), linear (multiply-add, divide-add) and hyperbolic functions.

Features

- Modes of operation
 - Supports all CORDIC operating modes for solving circular (trigonometric), linear (multiply-add, divide-add) and hyperbolic functions
 - Integrated look-up tables (LUTs) for all operating modes
- Circular vectoring mode: Extended support for values of initial X and Y data up to full range of $[-2^{15}, (2^{15}-1)]$ for solving angle and magnitude
- Circular rotation mode: Extended support for values of initial Z data up to full range of $[-2^{15}, (2^{15}-1)]$, representing angles in the range $[-\pi, ((2^{15}-1)/2^{15})\pi]$ for solving trigonometry
- Implementation-dependent operational frequency of up to 80 MHz
- Gated clock input to support disabling of module
- 16-bit accessible data width
 - 24-bit kernel data width plus 2 overflow bits for X and Y each
 - 20-bit kernel data width plus 1 overflow bit for Z
 - With KEEP bit to retain the last value in the kernel register for a new calculation
- 16 iterations per calculation: Approximately 41 clock-cycles or less, from set of start (ST) bit to set of end-of-calculation flag, excluding time taken for write and read access of data bytes.
- Twos complement data processing
 - Only exception: X result data with user selectable option for unsigned result
- X and Y data generally accepted as integer or rational number; X and Y must be of the same data form
- Entries of LUTs are 20-bit signed integers
 - Entries of atan and atanh LUTs are integer representations (S19) of angles with the scaling such that $[-2^{15}, (2^{15}-1)]$ represents the range $[-\pi, ((2^{15}-1)/2^{15})\pi]$
 - Accessible Z result data for circular and hyperbolic functions is integer in data form of S15
- Emulated LUT for linear function
 - Data form is 1 integer bit and 15-bit fractional part (1.15)
 - Accessible Z result data for linear function is rational number with fixed data form of S4.11 (signed 4Q16)
- Truncation Error
 - The result of a CORDIC calculation may return an approximation due to truncation of LSBs
 - Good accuracy of the CORDIC calculated result data, especially in circular mode
- Interrupt
 - On completion of a calculation

- Interrupt enabling and corresponding flag

3.13 UART and UART1

The SAA-XC886 provides two Universal Asynchronous Receiver/Transmitter (UART and UART1) modules for full-duplex asynchronous reception/transmission. Both are also receive-buffered, i.e., they can commence reception of a second byte before a previously received byte has been read from the receive register. However, if the first byte still has not been read by the time reception of the second byte is complete, one of the bytes will be lost.

Features

- Full-duplex asynchronous modes
 - 8-bit or 9-bit data frames, LSB first
 - Fixed or variable baud rate
- Receive buffered
- Multiprocessor communication
- Interrupt generation on the completion of a data transmission or reception

The UART modules can operate in the four modes shown in [Table 28](#).

Table 28 **UART Modes**

Operating Mode	Baud Rate
Mode 0: 8-bit shift register	$f_{PCLK}/2$
Mode 1: 8-bit shift UART	Variable
Mode 2: 9-bit shift UART	$f_{PCLK}/32$ or $f_{PCLK}/64$ ¹⁾
Mode 3: 9-bit shift UART	Variable

1) For UART1 module, the baud rate is fixed at $f_{PCLK}/64$.

There are several ways to generate the baud rate clock for the serial port, depending on the mode in which it is operating. In mode 0, the baud rate for the transfer is fixed at $f_{PCLK}/2$. In mode 2, the baud rate is generated internally based on the UART input clock and can be configured to either $f_{PCLK}/32$ or $f_{PCLK}/64$. For UART1 module, only $f_{PCLK}/64$ is available. The variable baud rate is set by the underflow rate on the dedicated baud-rate generator. For UART module, the variable baud rate alternatively can be set by the overflow rate on Timer 1.

3.13.1 Baud-Rate Generator

Both UART modules have their own dedicated baud-rate generator, which is based on a programmable 8-bit reload value, and includes divider stages (i.e., prescaler and

Functional Description

fractional divider) for generating a wide range of baud rates based on its input clock f_{PCLK} , see [Figure 29](#).

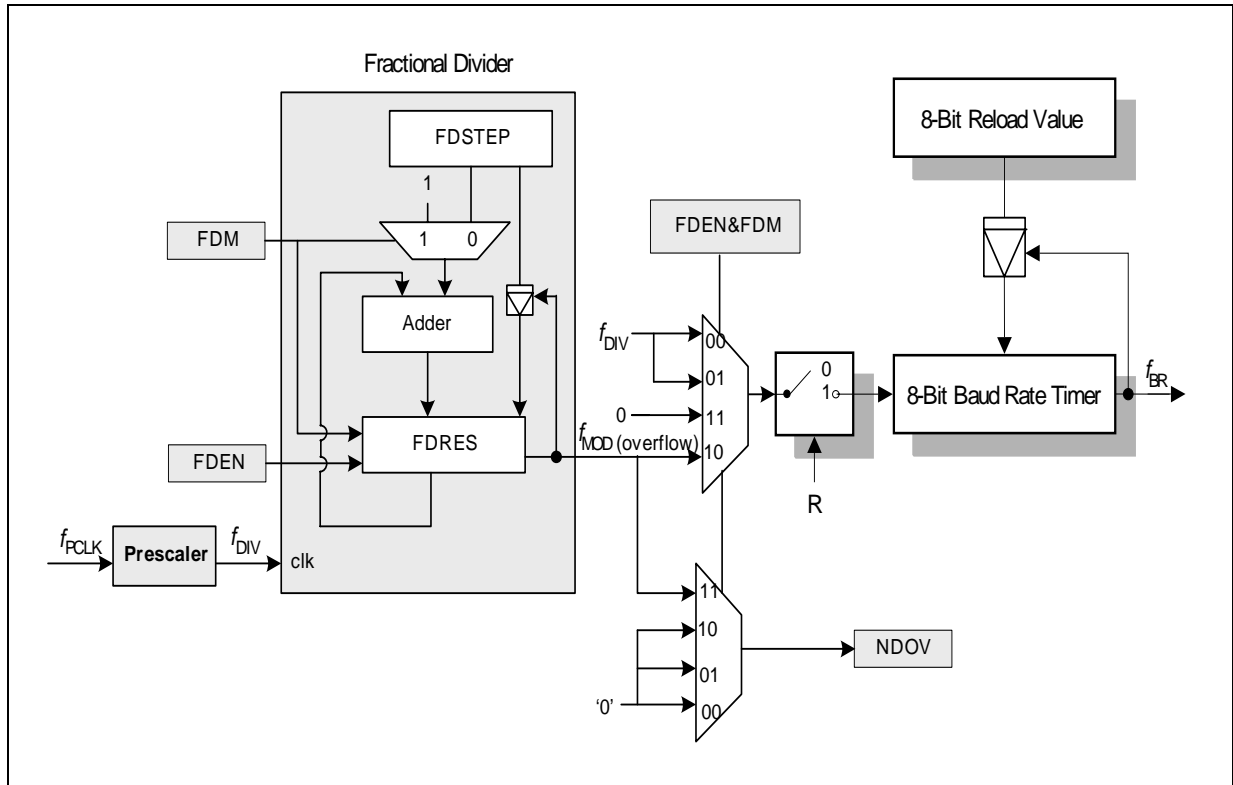

Figure 29 Baud-rate Generator Circuitry

The baud rate timer is a count-down timer and is clocked by either the output of the fractional divider (f_{MOD}) if the fractional divider is enabled ($FDEN = 1$), or the output of the prescaler (f_{DIV}) if the fractional divider is disabled ($FDEN = 0$). For baud rate generation, the fractional divider must be configured to fractional divider mode ($FDM = 0$). This allows the baud rate control run bit $BCON.R$ to be used to start or stop the baud rate timer. At each timer underflow, the timer is reloaded with the 8-bit reload value in register BG and one clock pulse is generated for the serial channel.

Enabling the fractional divider in normal divider mode ($FDEN = 1$ and $FDM = 1$) stops the baud rate timer and nullifies the effect of bit $BCON.R$. See [Section 3.14](#).

The baud rate (f_{BR}) value is dependent on the following parameters:

- Input clock f_{PCLK}
- Prescaling factor (2^{BRPRE}) defined by bit field $BRPRE$ in register $BCON$
- Fractional divider ($STEP/256$) defined by register $FDSTEP$ (to be considered only if fractional divider is enabled and operating in fractional divider mode)
- 8-bit reload value (BR_VALUE) for the baud rate timer defined by register BG

Functional Description

The following formulas calculate the final baud rate without and with the fractional divider respectively:

$$\text{baud rate} = \frac{f_{\text{PCLK}}}{16 \times 2^{\text{BRPRE}} \times (\text{BR_VALUE} + 1)} \quad \text{where } 2^{\text{BRPRE}} \times (\text{BR_VALUE} + 1) > 1$$

(3.5)

$$\text{baud rate} = \frac{f_{\text{PCLK}}}{16 \times 2^{\text{BRPRE}} \times (\text{BR_VALUE} + 1)} \times \frac{\text{STEP}}{256}$$

(3.6)

The maximum baud rate that can be generated is limited to $f_{\text{PCLK}}/32$. Hence, for a module clock of 24 MHz, the maximum achievable baud rate is 0.75 MBaud.

Standard LIN protocol can support a maximum baud rate of 20 kHz, the baud rate accuracy is not critical and the fractional divider can be disabled. Only the prescaler is used for auto baud rate calculation. For LIN fast mode, which supports the baud rate of 20 kHz to 115.2 kHz, the higher baud rates require the use of the fractional divider for greater accuracy.

Table 29 lists the various commonly used baud rates with their corresponding parameter settings and deviation errors. The fractional divider is disabled and a module clock of 24 MHz is used.

Table 29 Typical Baud rates for UART with Fractional Divider disabled

Baud rate	Prescaling Factor (2BRPRE)	Reload Value (BR_VALUE + 1)	Deviation Error
19.2 kBaud	1 (BRPRE=000 _B)	78 (4E _H)	0.17 %
9600 Baud	1 (BRPRE=000 _B)	156 (9C _H)	0.17 %
4800 Baud	2 (BRPRE=001 _B)	156 (9C _H)	0.17 %
2400 Baud	4 (BRPRE=010 _B)	156 (9C _H)	0.17 %

The fractional divider allows baud rates of higher accuracy (lower deviation error) to be generated. **Table 30** lists the resulting deviation errors from generating a baud rate of 115.2 kHz, using different module clock frequencies. The fractional divider is enabled (fractional divider mode) and the corresponding parameter settings are shown.

Table 30 Deviation Error for UART with Fractional Divider enabled

f_{PCLK}	Prescaling Factor (2BRPRE)	Reload Value (BR_VALUE + 1)	STEP	Deviation Error
24 MHz	1	10 (A_H)	197 ($C5_H$)	+0.20 %
12 MHz	1	6 (6_H)	236 (EC_H)	+0.03 %
8 MHz	1	4 (4_H)	236 (EC_H)	+0.03 %
6 MHz	1	3 (3_H)	236 (EC_H)	+0.03 %

3.13.2 Baud Rate Generation using Timer 1

In UART modes 1 and 3 of UART module, Timer 1 can be used for generating the variable baud rates. In theory, this timer could be used in any of its modes. But in practice, it should be set into auto-reload mode (Timer 1 mode 2), with its high byte set to the appropriate value for the required baud rate. The baud rate is determined by the Timer 1 overflow rate and the value of SMOD as follows:

$$\text{Mode 1, 3 baud rate} = \frac{2^{\text{SMOD}} \times f_{PCLK}}{32 \times 2 \times (256 - \text{TH1})} \quad (3.7)$$

3.14 Normal Divider Mode (8-bit Auto-reload Timer)

Setting bit FDM in register FDCON to 1 configures the fractional divider to normal divider mode, while at the same time disables baud rate generation (see [Figure 29](#)). Once the fractional divider is enabled (FDEN = 1), it functions as an 8-bit auto-reload timer (with no relation to baud rate generation) and counts up from the reload value with each input clock pulse. Bit field RESULT in register FDRES represents the timer value, while bit field STEP in register FDSTEP defines the reload value. At each timer overflow, an overflow flag (FDCON.NDOV) will be set and an interrupt request generated. This gives an output clock f_{MOD} that is 1/n of the input clock f_{DIV} , where n is defined by 256 - STEP. The output frequency in normal divider mode is derived as follows:

$$f_{MOD} = f_{DIV} \times \frac{1}{256 - \text{STEP}} \quad (3.8)$$

3.15 LIN Protocol

The UART module can be used to support the Local Interconnect Network (LIN) protocol for both master and slave operations. The LIN baud rate detection feature, which consists of the hardware logic for Break and Synch Byte detection, provides the capability to detect the baud rate within LIN protocol using Timer 2. This allows the UART to be synchronized to the LIN baud rate for data transmission and reception.

Note: The LIN baud rate detection feature is available for use only with UART. To use UART1 for LIN communication, software has to be implemented to detect the Break and Synch Byte.

LIN is a holistic communication concept for local interconnected networks in vehicles. The communication is based on the SCI (UART) data format, a single-master/multiple-slave concept, a clock synchronization for nodes without stabilized time base. An attractive feature of LIN is self-synchronization of the slave nodes without a crystal or ceramic resonator, which significantly reduces the cost of hardware platform. Hence, the baud rate must be calculated and returned with every message frame.

The structure of a LIN frame is shown in **Figure 30**. The frame consists of the:

- Header, which comprises a Break (13-bit time low), Synch Byte (55_H), and ID field
- Response time
- Data bytes (according to UART protocol)
- Checksum

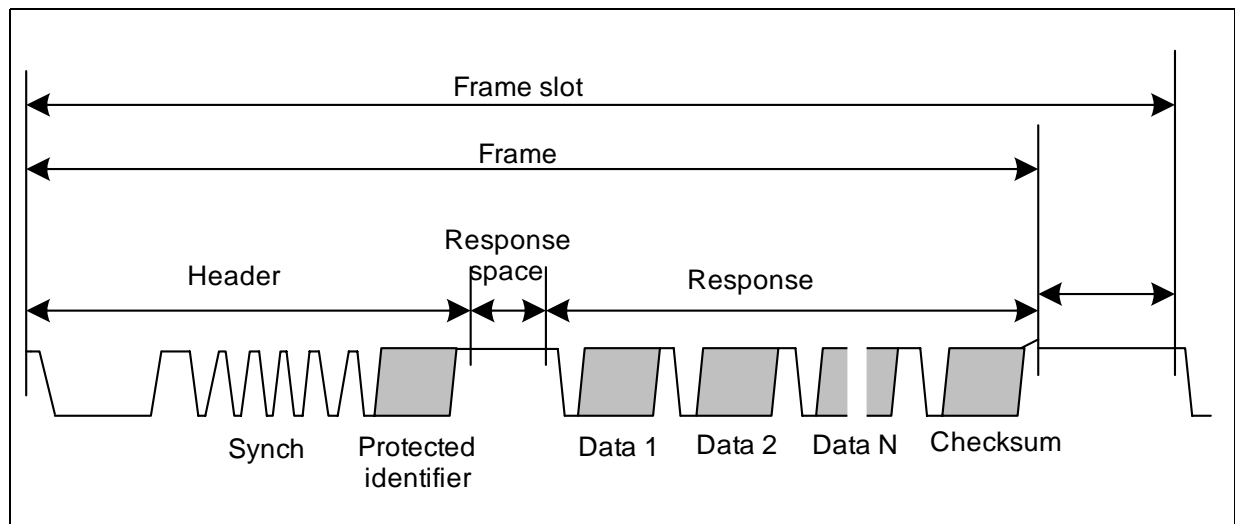

Figure 30 Structure of LIN Frame

3.15.1 LIN Header Transmission

LIN header transmission is only applicable in master mode. In the LIN communication, a master task decides when and which frame is to be transferred on the bus. It also identifies a slave task to provide the data transported by each frame. The information needed for the handshaking between the master and slave tasks is provided by the master task through the header portion of the frame.

The header consists of a break and synch pattern followed by an identifier. Among these three fields, only the break pattern cannot be transmitted as a normal 8-bit UART data. The break must contain a dominant value of 13 bits or more to ensure proper synchronization of slave nodes.

In the LIN communication, a slave task is required to be synchronized at the beginning of the protected identifier field of frame. For this purpose, every frame starts with a sequence consisting of a break field followed by a synch byte field. This sequence is unique and provides enough information for any slave task to detect the beginning of a new frame and be synchronized at the start of the identifier field.

Upon entering LIN communication, a connection is established and the transfer speed (baud rate) of the serial communication partner (host) is automatically synchronized in the following steps:

STEP 1: Initialize interface for reception and timer for baud rate measurement

STEP 2: Wait for an incoming LIN frame from host

STEP 3: Synchronize the baud rate to the host

STEP 4: Enter for Master Request Frame or for Slave Response Frame

*Note: Re-synchronization and setup of baud rate are always done for **every** Master Request Header or Slave Response Header LIN frame.*

3.16 High-Speed Synchronous Serial Interface

The High-Speed Synchronous Serial Interface (SSC) supports full-duplex and half-duplex synchronous communication. The serial clock signal can be generated by the SSC internally (master mode), using its own 16-bit baud-rate generator, or can be received from an external master (slave mode). Data width, shift direction, clock polarity and phase are programmable. This allows communication with SPI-compatible devices or devices using other synchronous serial interfaces.

Features

- Master and slave mode operation
 - Full-duplex or half-duplex operation
- Transmit and receive buffered
- Flexible data format
 - Programmable number of data bits: 2 to 8 bits
 - Programmable shift direction: LSB or MSB shift first
 - Programmable clock polarity: idle low or high state for the shift clock
 - Programmable clock/data phase: data shift with leading or trailing edge of the shift clock
- Variable baud rate
- Compatible with Serial Peripheral Interface (SPI)
- Interrupt generation
 - On a transmitter empty condition
 - On a receiver full condition
 - On an error condition (receive, phase, baud rate, transmit error)

Data is transmitted or received on lines TXD and RXD, which are normally connected to the pins MTSR (Master Transmit/Slave Receive) and MRST (Master Receive/Slave Transmit). The clock signal is output via line MS_CLK (Master Serial Shift Clock) or input via line SS_CLK (Slave Serial Shift Clock). Both lines are normally connected to the pin SCLK. Transmission and reception of data are double-buffered.

Figure 31 shows the block diagram of the SSC.

Functional Description

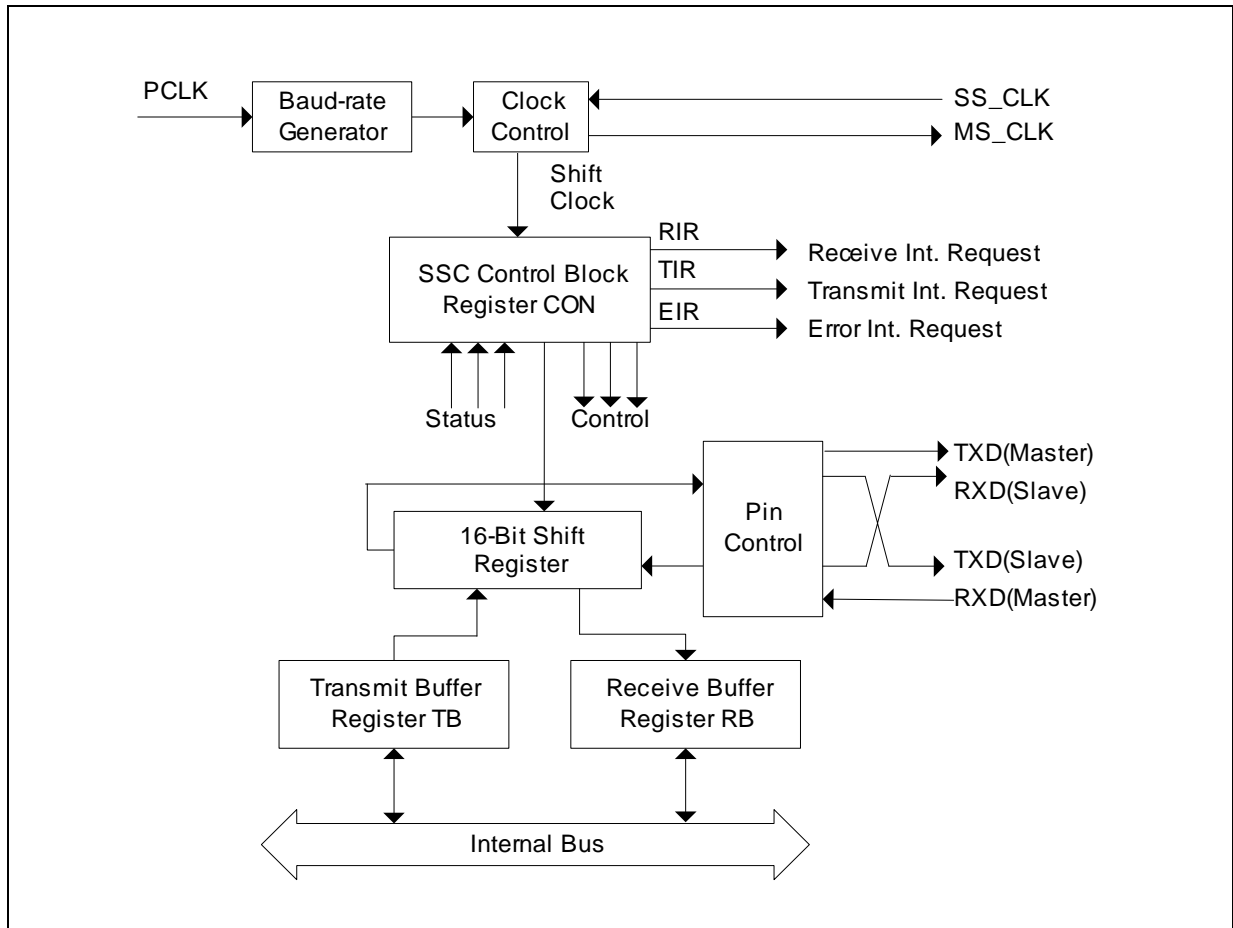

Figure 31 SSC Block Diagram

3.17 Timer 0 and Timer 1

Timer 0 and Timer 1 can function as both timers or counters. When functioning as a timer, Timer 0 and Timer 1 are incremented every machine cycle, i.e. every 2 input clocks (or 2 PCLKs). When functioning as a counter, Timer 0 and Timer 1 are incremented in response to a 1-to-0 transition (falling edge) at their respective external input pins, T0 or T1.

Timer 0 and 1 are fully compatible and can be configured in four different operating modes for use in a variety of applications, see [Table 31](#). In modes 0, 1 and 2, the two timers operate independently, but in mode 3, their functions are specialized.

Table 31 Timer 0 and Timer 1 Modes

Mode	Operation
0	13-bit timer The timer is essentially an 8-bit counter with a divide-by-32 prescaler. This mode is included solely for compatibility with Intel 8048 devices.
1	16-bit timer The timer registers, TLx and THx, are concatenated to form a 16-bit counter.
2	8-bit timer with auto-reload The timer register TLx is reloaded with a user-defined 8-bit value in THx upon overflow.
3	Timer 0 operates as two 8-bit timers The timer registers, TL0 and TH0, operate as two separate 8-bit counters. Timer 1 is halted and retains its count even if enabled.

3.18 Timer 2 and Timer 21

Timer 2 and Timer 21 are 16-bit general purpose timers (THL2) that are fully compatible and have two modes of operation, a 16-bit auto-reload mode and a 16-bit one channel capture mode, see [Table 32](#). As a timer, the timers count with an input clock of PCLK/12 (if prescaler is disabled). As a counter, they count 1-to-0 transitions on pin T2. In the counter mode, the maximum resolution for the count is PCLK/24 (if prescaler is disabled).

Table 32 Timer 2 Modes

Mode	Description
Auto-reload	Up/Down Count Disabled <ul style="list-style-type: none"> • Count up only • Start counting from 16-bit reload value, overflow at FFFF_H • Reload event configurable for trigger by overflow condition only, or by negative/positive edge at input pin T2EX as well • Programmable reload value in register RC2 • Interrupt is generated with reload event
	Up/Down Count Enabled <ul style="list-style-type: none"> • Count up or down, direction determined by level at input pin T2EX • No interrupt is generated • Count up <ul style="list-style-type: none"> – Start counting from 16-bit reload value, overflow at FFFF_H – Reload event triggered by overflow condition – Programmable reload value in register RC2 • Count down <ul style="list-style-type: none"> – Start counting from FFFF_H, underflow at value defined in register RC2 – Reload event triggered by underflow condition – Reload value fixed at FFFF_H
Channel capture	<ul style="list-style-type: none"> • Count up only • Start counting from 0000_H, overflow at FFFF_H • Reload event triggered by overflow condition • Reload value fixed at 0000_H • Capture event triggered by falling/rising edge at pin T2EX • Captured timer value stored in register RC2 • Interrupt is generated with reload or capture event

3.19 Capture/Compare Unit 6

The Capture/Compare Unit 6 (CCU6) provides two independent timers (T12, T13), which can be used for Pulse Width Modulation (PWM) generation, especially for AC-motor control. The CCU6 also supports special control modes for block commutation and multi-phase machines.

The timer T12 can function in capture and/or compare mode for its three channels. The timer T13 can work in compare mode only.

The multi-channel control unit generates output patterns, which can be modulated by T12 and/or T13. The modulation sources can be selected and combined for the signal modulation.

Timer T12 Features

- Three capture/compare channels, each channel can be used either as a capture or as a compare channel
- Supports generation of a three-phase PWM (six outputs, individual signals for highside and lowside switches)
- 16-bit resolution, maximum count frequency = peripheral clock frequency
- Dead-time control for each channel to avoid short-circuits in the power stage
- Concurrent update of the required T12/13 registers
- Generation of center-aligned and edge-aligned PWM
- Supports single-shot mode
- Supports many interrupt request sources
- Hysteresis-like control mode

Timer T13 Features

- One independent compare channel with one output
- 16-bit resolution, maximum count frequency = peripheral clock frequency
- Can be synchronized to T12
- Interrupt generation at period-match and compare-match
- Supports single-shot mode

Additional Features

- Implements block commutation for Brushless DC-drives
- Position detection via Hall-sensor pattern
- Automatic rotational speed measurement for block commutation
- Integrated error handling
- Fast emergency stop without CPU load via external signal ($\overline{\text{CTRAP}}$)
- Control modes for multi-channel AC-drives
- Output levels can be selected and adapted to the power stage

The block diagram of the CCU6 module is shown in [Figure 32](#).

Functional Description

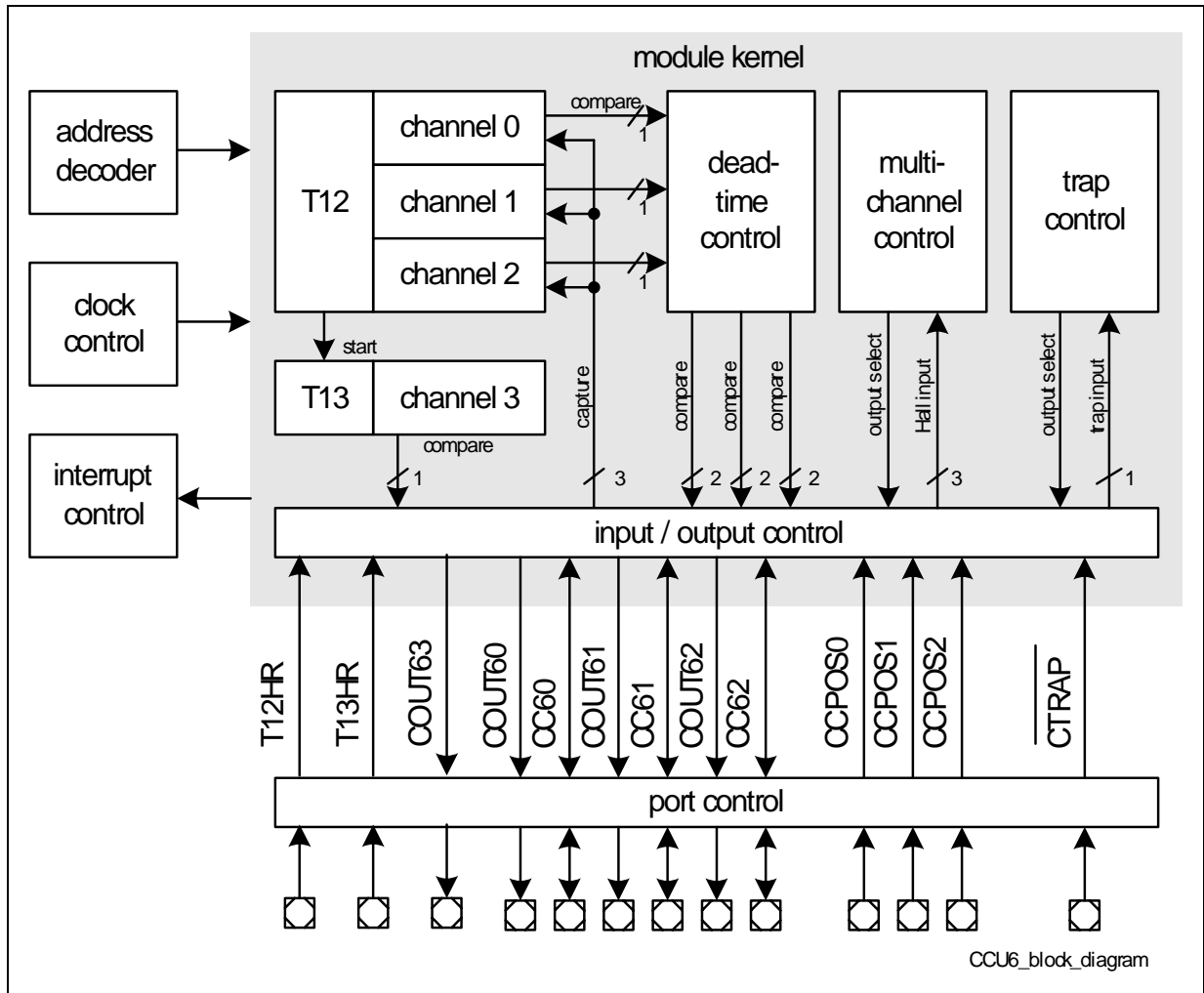

Figure 32 CCU6 Block Diagram

Functional Description

3.20 Controller Area Network (MultiCAN)

The MultiCAN module contains two Full-CAN nodes operating independently or exchanging data and remote frames via a gateway function. Transmission and reception of CAN frames is handled in accordance to CAN specification V2.0 B active. Each CAN node can receive and transmit standard frames with 11-bit identifiers as well as extended frames with 29-bit identifiers.

Both CAN nodes share a common set of message objects, where each message object may be individually allocated to one of the CAN nodes. Besides serving as a storage container for incoming and outgoing frames, message objects may be combined to build gateways between the CAN nodes or to setup a FIFO buffer.

The message objects are organized in double chained lists, where each CAN node has it's own list of message objects. A CAN node stores frames only into message objects that are allocated to the list of the CAN node. It only transmits messages from objects of this list. A powerful, command driven list controller performs all list operations.

The bit timings for the CAN nodes are derived from the peripheral clock (f_{CAN}) and are programmable up to a data rate of 1 MBaud. A pair of receive and transmit pins connects each CAN node to a bus transceiver.

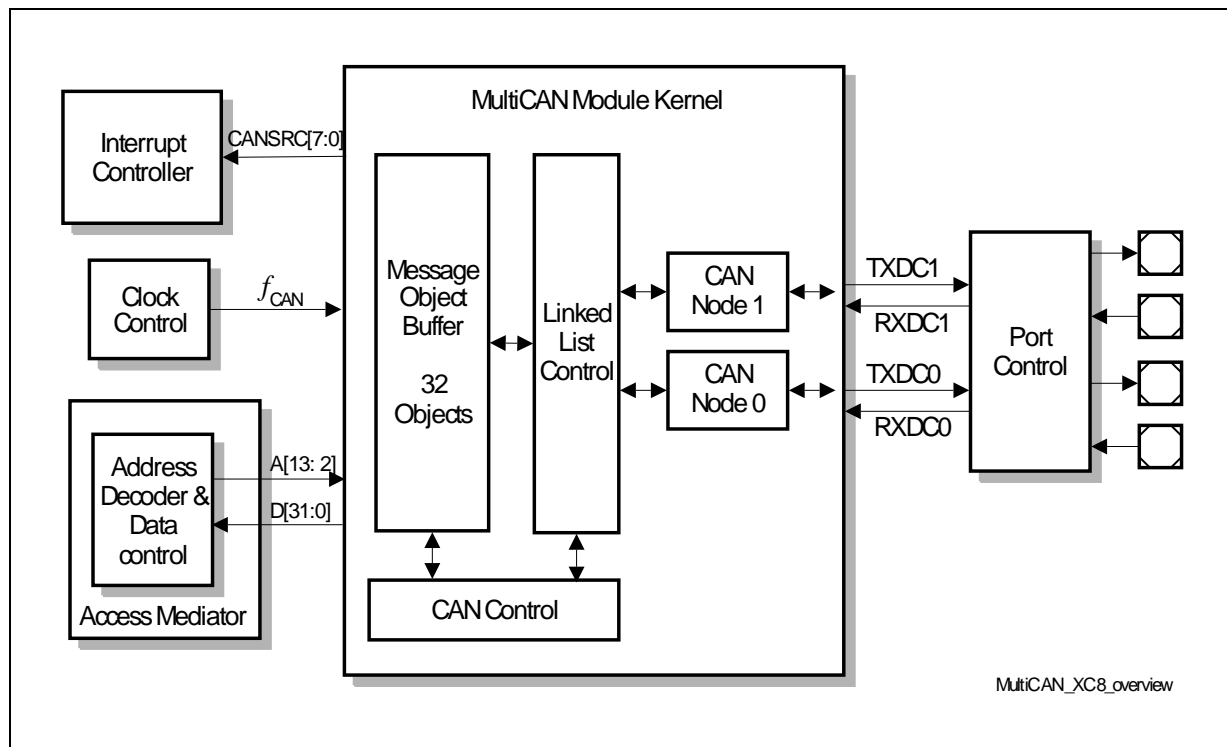

Figure 33 Overview of the MultiCAN

Features

- Compliant to ISO 11898.

Functional Description

- CAN functionality according to CAN specification V2.0 B active.
- Dedicated control registers are provided for each CAN node.
- A data transfer rate up to 1 MBaud is supported.
- Flexible and powerful message transfer control and error handling capabilities are implemented.
- Advanced CAN bus bit timing analysis and baud rate detection can be performed for each CAN node via the frame counter.
- Full-CAN functionality: A set of 32 message objects can be individually
 - allocated (assigned) to any CAN node
 - configured as transmit or receive object
 - setup to handle frames with 11-bit or 29-bit identifier
 - counted or assigned a timestamp via a frame counter
 - configured to remote monitoring mode
- Advanced Acceptance Filtering:
 - Each message object provides an individual acceptance mask to filter incoming frames.
 - A message object can be configured to accept only standard or only extended frames or to accept both standard and extended frames.
 - Message objects can be grouped into 4 priority classes.
 - The selection of the message to be transmitted first can be performed on the basis of frame identifier, IDE bit and RTR bit according to CAN arbitration rules.
- Advanced Message Object Functionality:
 - Message Objects can be combined to build FIFO message buffers of arbitrary size, which is only limited by the total number of message objects.
 - Message objects can be linked to form a gateway to automatically transfer frames between 2 different CAN buses. A single gateway can link any two CAN nodes. An arbitrary number of gateways may be defined.
- Advanced Data Management:
 - The Message objects are organized in double chained lists.
 - List reorganizations may be performed any time, even during full operation of the CAN nodes.
 - A powerful, command driven list controller manages the organization of the list structure and ensures consistency of the list.
 - Message FIFOs are based on the list structure and can easily be scaled in size during CAN operation.
 - Static Allocation Commands offer compatibility with TwinCAN applications, which are not list based.
- Advanced Interrupt Handling:
 - Up to 8 interrupt output lines are available. Most interrupt requests can be individually routed to one of the 8 interrupt output lines.
 - Message postprocessing notifications can be flexibly aggregated into a dedicated register field of 64 notification bits.

3.21 Analog-to-Digital Converter

The SAA-XC886 includes a high-performance 10-bit Analog-to-Digital Converter (ADC) with eight multiplexed analog input channels. The ADC uses a successive approximation technique to convert the analog voltage levels from up to eight different sources. The analog input channels of the ADC are available at Port 2.

Features

- Successive approximation
- 8-bit or 10-bit resolution (TUE of ± 1 LSB and ± 2 LSB, respectively)
- Eight analog channels
- Four independent result registers
- Result data protection for slow CPU access (wait-for-read mode)
- Single conversion mode
- Autoscan functionality
- Limit checking for conversion results
- Data reduction filter (accumulation of up to 2 conversion results)
- Two independent conversion request sources with programmable priority
- Selectable conversion request trigger
- Flexible interrupt generation with configurable service nodes
- Programmable sample time
- Programmable clock divider
- Cancel/restart feature for running conversions
- Integrated sample and hold circuitry
- Compensation of offset errors
- Low power modes

3.21.1 ADC Clocking Scheme

A common module clock f_{ADC} generates the various clock signals used by the analog and digital parts of the ADC module:

- f_{ADCA} is input clock for the analog part.
- f_{ADCI} is internal clock for the analog part (defines the time base for conversion length and the sample time). This clock is generated internally in the analog part, based on the input clock f_{ADCA} to generate a correct duty cycle for the analog components.
- f_{ADCD} is input clock for the digital part.

The internal clock for the analog part f_{ADCI} is limited to a maximum frequency of 10 MHz. Therefore, the ADC clock prescaler must be programmed to a value that ensures f_{ADCI} does not exceed 10 MHz. The prescaler ratio is selected by bit field CTC in register

Functional Description

GLOBCTR. A prescaling ratio of 32 can be selected when the maximum performance of the ADC is not required.

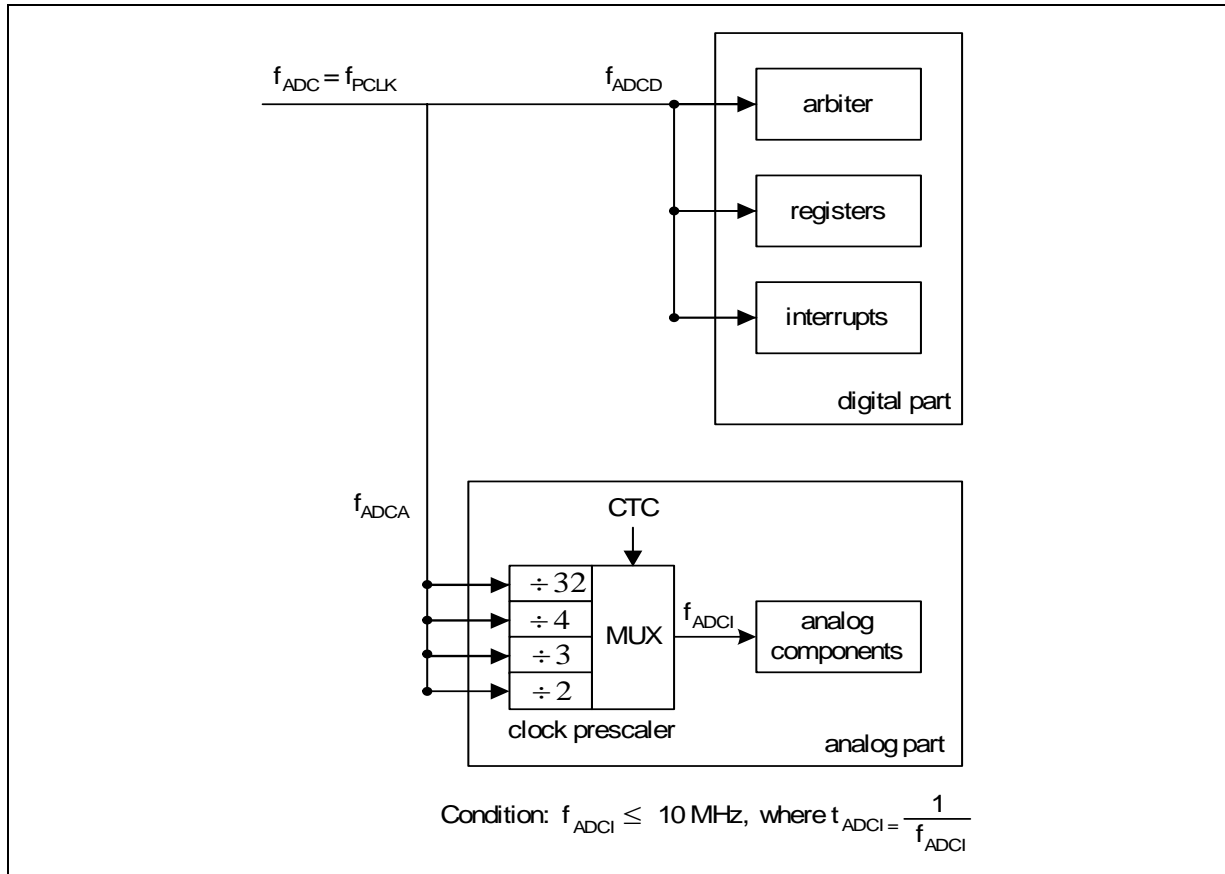

Figure 34 ADC Clocking Scheme

For module clock $f_{ADC} = 24 \text{ MHz}$, the analog clock f_{ADCL} frequency can be selected as shown in Table 33.

Table 33 f_{ADCL} Frequency Selection

Module Clock f_{ADC}	CTC	Prescaling Ratio	Analog Clock f_{ADCL}
24 MHz	00 _B	÷ 2	12 MHz (N.A)
	01 _B	÷ 3	8 MHz
	10 _B	÷ 4	6 MHz
	11 _B (default)	÷ 32	750 kHz

As f_{ADCL} cannot exceed 10 MHz, bit field CTC should not be set to 00_B when f_{ADC} is 24 MHz. During slow-down mode where f_{ADC} may be reduced to 12 MHz, 6 MHz etc., CTC can be set to 00_B as long as the divided analog clock f_{ADCL} does not exceed 10 MHz.

Functional Description

However, it is important to note that the conversion error could increase due to loss of charges on the capacitors, if f_{ADC} becomes too low during slow-down mode.

3.21.2 ADC Conversion Sequence

The analog-to-digital conversion procedure consists of the following phases:

- Synchronization phase (t_{SYN})
- Sample phase (t_S)
- Conversion phase
- Write result phase (t_{WR})

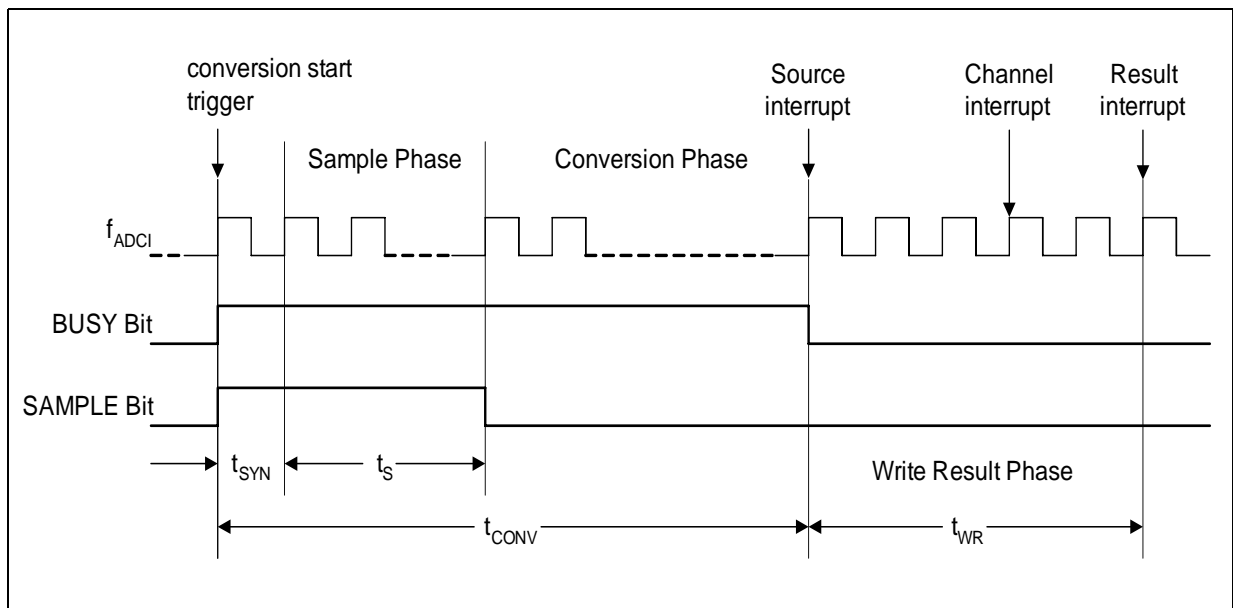

Figure 35 ADC Conversion Timing

3.22 On-Chip Debug Support

The On-Chip Debug Support (OCDS) provides the basic functionality required for the software development and debugging of XC800-based systems.

The OCDS design is based on these principles:

- Use the built-in debug functionality of the XC800 Core
- Add a minimum of hardware overhead
- Provide support for most of the operations by a Monitor Program
- Use standard interfaces to communicate with the Host (a Debugger)

Features

- Set breakpoints on instruction address and on address range within the Program Memory
- Set breakpoints on internal RAM address range
- Support unlimited software breakpoints in Flash/RAM code region
- Process external breaks via JTAG and upon activating a dedicated pin
- Step through the program code

The OCDS functional blocks are shown in [Figure 36](#). The Monitor Mode Control (MMC) block at the center of OCDS system brings together control signals and supports the overall functionality. The MMC communicates with the XC800 Core, primarily via the Debug Interface, and also receives reset and clock signals.

After processing memory address and control signals from the core, the MMC provides proper access to the dedicated extra-memories: a Monitor ROM (holding the code) and a Monitor RAM (for work-data and Monitor-stack).

The OCDS system¹⁾ is accessed through the JTAG¹⁾, which is an interface dedicated exclusively for testing and debugging activities and is not normally used in an application. The dedicated MBC pin is used for external configuration and debugging control.

Note: All the debug functionality described here can normally be used only after SAA-XC886 has been started in OCDS mode.

1) The pins of the JTAG port can be assigned to either the primary port (Port 0) or either of the secondary ports (Ports 1 and 2/Port 5).

User must set the JTAG pins (TCK and TDI) as input during connection with the OCDS system.

Functional Description

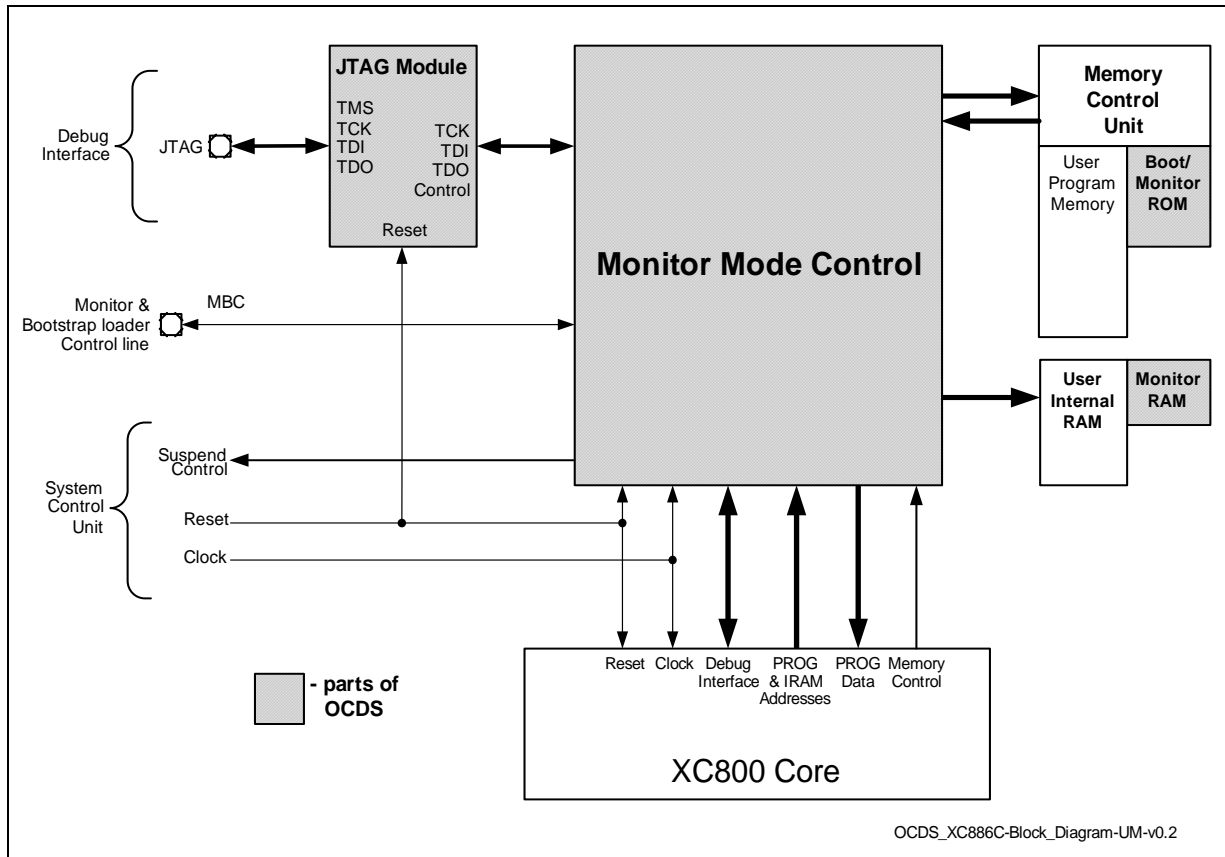

Figure 36 OCDS Block Diagram

3.22.1 JTAG ID Register

This is a read-only register located inside the JTAG module, and is used to recognize the device(s) connected to the JTAG interface. Its content is shifted out when INSTRUCTION register contains the IDCODE command (opcode 04_H), and the same is also true immediately after reset.

The JTAG ID register contents for the SAA-XC886 Flash devices are given in [Table 34](#).

Table 34 JTAG ID Summary

Device Type	Device Name	JTAG ID
Flash	SAA-XC886*-8FF	1012 0083 _H
	SAA-XC886*-6FF	1012 5083 _H

Note: The asterisk (*) above denotes all possible device configurations.

3.23 Chip Identification Number

The SAA-XC886 identity (ID) register is located at Page 1 of address B3_H. The value of ID register is 09_H. However, for easy identification of product variants, the Chip Identification Number, which is a unique number assigned to each product variant, is available. The differentiation is based on the product, variant type and device step information.

Two methods are provided to read a device's chip identification number:

- In-application subroutine, GET_CHIP_INFO
- Bootstrap loader (BSL) mode A

Table 35 lists the chip identification numbers of available SAA-XC886 device variants.

Table 35 Chip Identification Number

Product Variant	Chip Identification Number		
	AB-Step	AB-Step	AC-Step
XC886CLM-8FFA 5V	-	09900102 _H	0B900102 _H
XC886LM-8FFA 5V	-	09900122 _H	0B900122 _H
XC886CLM-6FFA 5V	-	09951502 _H	0B951502 _H
XC886LM-6FFA 5V	-	09951522 _H	0B951522 _H
XC886CM-8FFA 5V	-	09980102 _H	0B980102 _H
XC886C-8FFA 5V	-	09980142 _H	0B980142 _H
XC886-8FFA 5V	-	09980162 _H	0B980162 _H
XC886CM-6FFA 5V	-	099D1502 _H	0B9D1502 _H
XC886C-6FFA 5V	-	099D1542 _H	0B9D1542 _H
XC886-6FFA 5V	-	099D1562 _H	0B9D1562 _H

4 Electrical Parameters

Chapter 4 provides the characteristics of the electrical parameters which are implementation-specific for the SAA-XC886.

4.1 General Parameters

The general parameters are described here to aid the users in interpreting the parameters mainly in **Section 4.2** and **Section 4.3**.

4.1.1 Parameter Interpretation

The parameters listed in this section represent partly the characteristics of the SAA-XC886 and partly its requirements on the system. To aid interpreting the parameters easily when evaluating them for a design, they are indicated by the abbreviations in the "Symbol" column:

- **CC**
These parameters indicate **C**ontroller **C**haracteristics, which are distinctive features of the SAA-XC886 and must be regarded for a system design.
- **SR**
These parameters indicate **S**ystem **R**equirements, which must be provided by the microcontroller system in which the SAA-XC886 is designed in.

4.1.2 Absolute Maximum Rating

Maximum ratings are the extreme limits to which the SAA-XC886 can be subjected to without permanent damage.

Table 36 Absolute Maximum Rating Parameters

Parameter	Symbol	Limit Values		Unit	Notes
		min.	max.		
Ambient temperature	T_A	-40	140	°C	under bias
Storage temperature	T_{ST}	-65	150	°C	¹⁾
Junction temperature	T_J	-40	150	°C	under bias ¹⁾
Voltage on power supply pin with respect to V_{SS}	V_{DDP}	-0.5	6	V	¹⁾
Voltage on any pin with respect to V_{SS}	V_{IN}	-0.5	$V_{DDP} + 0.5$ or max. 6	V	whichever is lower ¹⁾
Input current on any pin during overload condition	I_{IN}	-10	10	mA	¹⁾
Absolute sum of all input currents during overload condition	$\Sigma I_{IN} $	–	50	mA	¹⁾

¹⁾ Not subjected to production test, verified by design/characterization.

Note: Stresses above those listed under “Absolute Maximum Ratings” may cause permanent damage to the device. This is a stress rating only and functional operation of the device at these or any other conditions above those indicated in the operational sections of this specification is not implied. Exposure to absolute maximum rating conditions for extended periods may affect device reliability. During absolute maximum rating overload conditions ($V_{IN} > V_{DDP}$ or $V_{IN} < V_{SS}$) the voltage on V_{DDP} pin with respect to ground (V_{SS}) must not exceed the values defined by the absolute maximum ratings.

4.1.3 Operating Conditions

The following operating conditions must not be exceeded in order to ensure correct operation of the SAA-XC886. All parameters mentioned in the following table refer to these operating conditions, unless otherwise noted.

Table 37 Operating Condition Parameters

Parameter	Symbol	Limit Values		Unit	Notes/ Conditions
		min.	max.		
Digital power supply voltage	V_{DDP}	4.5	5.5	V	5V Device
Digital ground voltage	V_{SS}	0		V	
Digital core supply voltage	V_{DDC}	2.3	2.7	V	
System Clock Frequency ¹⁾	f_{SYS}	88.8	103.2	MHz	
Ambient temperature	T_A	-40	140	°C	SAA-XC886...

1) f_{SYS} is the PLL output clock. During normal operating mode, CPU clock is $f_{SYS} / 4$. Please refer to [Figure 25](#) for detailed description.

4.2 DC Parameters

The electrical characteristics of the DC Parameters are detailed in this section.

4.2.1 Input/Output Characteristics

Table 38 provides the characteristics of the input/output pins of the SAA-XC886.

Table 38 Input/Output Characteristics (Operating Conditions apply)

Parameter	Symbol		Limit Values		Unit	Test Conditions
			min.	max.		
$V_{DDP} = 5\text{ V Range}$						
Output low voltage	V_{OL}	CC	–	1.0	V	$I_{OL} = 15\text{ mA}$
			–	1.0	V	$I_{OL} = 5\text{ mA}$, current into all pins > 60 mA
			–	0.4	V	$I_{OL} = 5\text{ mA}$, current into all pins $\leq 60\text{ mA}$
Output high voltage	V_{OH}	CC	$V_{DDP} - 1.0$	–	V	$I_{OH} = -15\text{ mA}$
			$V_{DDP} - 1.0$	–	V	$I_{OH} = -5\text{ mA}$, current from all pins > 60 mA
			$V_{DDP} - 0.4$	–	V	$I_{OH} = -5\text{ mA}$, current from all pins $\leq 60\text{ mA}$
Input low voltage on port pins (all except P0.0 & P0.1)	V_{ILP}	SR	–	$0.3 \times V_{DDP}$	V	CMOS Mode
Input low voltage on P0.0 & P0.1	V_{ILP0}	SR	-0.2	$0.3 \times V_{DDP}$	V	CMOS Mode
Input low voltage on $\overline{\text{RESET}}$ pin	V_{ILR}	SR	–	$0.3 \times V_{DDP}$	V	CMOS Mode
Input low voltage on TMS pin	V_{ILT}	SR	–	$0.3 \times V_{DDP}$	V	CMOS Mode
Input high voltage on port pins (all except P0.0 & P0.1)	V_{IHP}	SR	$0.7 \times V_{DDP}$	–	V	CMOS Mode
Input high voltage on P0.0 & P0.1	V_{IHP0}	SR	$0.7 \times V_{DDP}$	V_{DDP}	V	CMOS Mode

Electrical Parameters
Table 38 Input/Output Characteristics (Operating Conditions apply) (cont'd)

Parameter	Symbol		Limit Values		Unit	Test Conditions
			min.	max.		
Input high voltage on RESET pin	V_{IHR}	SR	$0.7 \times V_{DDP}$	–	V	CMOS Mode
Input high voltage on TMS pin	V_{IHT}	SR	$0.75 \times V_{DDP}$	–	V	CMOS Mode
Input Hysteresis on port pins	$HYSP$	CC	$0.07 \times V_{DDP}$	–	V	CMOS Mode ¹⁾
Input Hysteresis on XTAL1	$HYSX$	CC	$0.07 \times V_{DDC}$	–	V	1)
Input low voltage at XTAL1	V_{ILX}	SR	$V_{SS} - 0.5$	$0.3 \times V_{DDC}$	V	
Input high voltage at XTAL1	V_{IHX}	SR	$0.7 \times V_{DDC}$	$V_{DDC} + 0.5$	V	
Pull-up current	I_{PU}	SR	–	-10	μA	$V_{IHP,min}$
			-150	–	μA	$V_{ILP,max}$
Pull-down current	I_{PD}	SR	–	10	μA	$V_{ILP,max}$
			150	–	μA	$V_{IHP,min}$
Input leakage current	I_{OZ1}	CC	-2	2	μA	$0 < V_{IN} < V_{DDP}$, $T_A \leq 140^\circ C$ ²⁾
Input current at XTAL1	I_{ILX}	CC	-10	10	μA	
Overload current on any pin	I_{OV}	SR	-5	5	mA	3)
Absolute sum of overload currents	$\Sigma I_{OV} $	SR	–	25	mA	3)
Voltage on any pin during V_{DDP} power off	V_{PO}	SR	–	0.3	V	4)
Maximum current per pin (excluding V_{DDP} and V_{SS})	I_M	SR SR	–	15	mA	
Maximum current for all pins (excluding V_{DDP} and V_{SS})	$\Sigma I_M $	SR	–	90	mA	

Electrical Parameters
Table 38 Input/Output Characteristics (Operating Conditions apply) (cont'd)

Parameter	Symbol	Limit Values		Unit	Test Conditions
		min.	max.		
Maximum current into V_{DDP}	I_{MVDDP} SR	–	120	mA	³⁾
Maximum current out of V_{SS}	I_{MVSS} SR	–	120	mA	³⁾

- 1) Not subjected to production test, verified by design/characterization. Hysteresis is implemented to avoid meta stable states and switching due to internal ground bounce. It cannot be guaranteed that it suppresses switching due to external system noise.
- 2) An additional error current (I_{INJ}) will flow if an overload current flows through an adjacent pin. TMS pin and $\overline{\text{RESET}}$ pin have internal pull devices and are not included in the input leakage current characteristic.
- 3) Not subjected to production test, verified by design/characterization.
- 4) Not subjected to production test, verified by design/characterization. However, for applications with strict low power-down current requirements, it is mandatory that no active voltage source is supplied at any GPIO pin when V_{DDP} is powered off.

4.2.2 Supply Threshold Characteristics

Table 39 provides the characteristics of the supply threshold in the SAA-XC886.

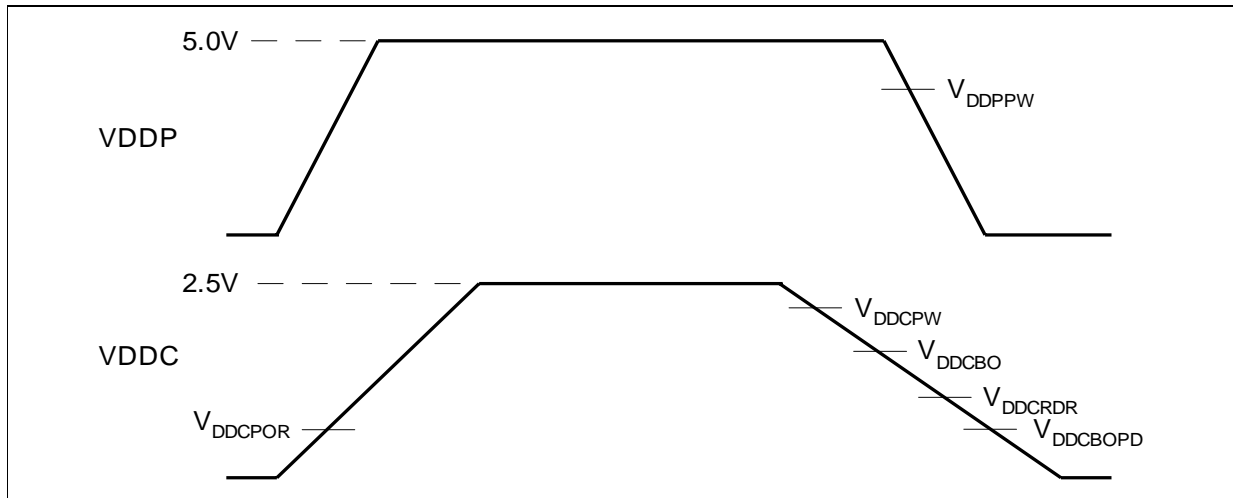

Figure 37 Supply Threshold Parameters

Table 39 Supply Threshold Parameters (Operating Conditions apply)

Parameters	Symbol		Limit Values			Unit
			min.	typ.	max.	
V_{DDC} prewarning voltage ¹⁾	V_{DDCPW}	CC	2.2	2.3	2.4	V
V_{DDC} brownout voltage in active mode ¹⁾	V_{DDCBO}	CC	2.0	2.1	2.2	V
RAM data retention voltage	V_{DDCRDR}	CC	0.9	1.0	1.1	V
V_{DDC} brownout voltage in power-down mode ²⁾	$V_{DDCBOPD}$	CC	1.3	1.5	1.7	V
V_{DDP} prewarning voltage ³⁾	V_{DDPPW}	CC	3.4	4.0	4.6	V
Power-on reset voltage ²⁾⁴⁾	V_{DDCPOR}	CC	1.3	1.5	1.7	V

1) Detection is disabled in power-down mode.

2) Detection is enabled in both active and power-down mode.

3) Detection is enabled for external power supply of 5.0V.

4) The reset of EVR is extended by 300 μ s typically after the VDDC reaches the power-on reset voltage.

4.2.3 ADC Characteristics

The values in the table below are given for an analog power supply between 4.5 V to 5.5 V. All ground pins (V_{SS}) must be externally connected to one single star point in the system. The voltage difference between the ground pins must not exceed 200mV.

Table 40 ADC Characteristics (Operating Conditions apply; $V_{DDP} = 5V$ Range)

Parameter	Symbol		Limit Values			Unit	Test Conditions/ Remarks
			min.	typ .	max.		
Analog reference voltage	V_{AREF}	SR	$V_{AGND} + 1$	V_{DDP}	$V_{DDP} + 0.05$	V	¹⁾
Analog reference ground	V_{AGND}	SR	$V_{SS} - 0.05$	V_{SS}	$V_{AREF} - 1$	V	¹⁾
Analog input voltage range	V_{AIN}	SR	V_{AGND}	–	V_{AREF}	V	
ADC clocks	f_{ADC}		–	24	25.8	MHz	module clock ¹⁾
	f_{ADCI}		–	–	10	MHz	internal analog clock ¹⁾ See Figure 34
Sample time	t_S	CC	$(2 + INPCR0.STC) \times t_{ADCI}$			μs	¹⁾
Conversion time	t_C	CC	See Section 4.2.3.1			μs	¹⁾
Total unadjusted error	TUE	CC	–	–	1	LSB	8-bit conversion ²⁾
			–	–	2	LSB	10-bit conversion ²⁾
Differential Nonlinearity	$ EA_{DNL} $	CC	–	1	–	LSB	10-bit conversion ¹⁾
Integral Nonlinearity	$ EA_{INL} $	CC	–	1	–	LSB	10-bit conversion ¹⁾
Offset	$ EA_{OFF} $	CC	–	1	–	LSB	10-bit conversion ¹⁾
Gain	$ EA_{GAIN} $	CC	–	1	–	LSB	10-bit conversion ¹⁾
Overload current coupling factor for analog inputs	K_{OVA}	CC	–	–	1.0×10^{-4}	–	$I_{OV} > 0^{1)3)}$
			–	–	1.5×10^{-3}	–	$I_{OV} < 0^{1)3)}$
Overload current coupling factor for digital I/O pins	K_{OVD}	CC	–	–	5.0×10^{-3}	–	$I_{OV} > 0^{1)3)}$
			–	–	1.0×10^{-2}	–	$I_{OV} < 0^{1)3)}$

Electrical Parameters
Table 40 ADC Characteristics (Operating Conditions apply; $V_{DDP} = 5V$ Range)

Parameter	Symbol	Limit Values			Unit	Test Conditions/ Remarks
		min.	typ.	max.		
Switched capacitance at the reference voltage input	C_{AREFSW} CC	–	10	20	pF	1)4)
Switched capacitance at the analog voltage inputs	C_{AINSW} CC	–	5	7	pF	1)5)
Input resistance of the reference input	R_{AREF} CC	–	1	2	k Ω	1)
Input resistance of the selected analog channel	R_{AIN} CC	–	1	1.5	k Ω	1)

- 1) Not subjected to production test, verified by design/characterization
- 2) TUE is tested at $V_{AREF} = 5.0 V$, $V_{AGND} = 0 V$, $V_{DDP} = 5.0 V$.
- 3) An overload current (I_{OV}) through a pin injects a certain error current (I_{INJ}) into the adjacent pins. This error current adds to the respective pin's leakage current (I_{OZ}). The amount of error current depends on the overload current and is defined by the overload coupling factor K_{OV} . The polarity of the injected error current is inverse compared to the polarity of the overload current that produces it. The total current through a pin is $|I_{TOT}| = |I_{OZ1}| + (|I_{OV}| \times K_{OV})$. The additional error current may distort the input voltage on analog inputs.
- 4) This represents an equivalent switched capacitance. This capacitance is not switched to the reference voltage at once. Instead of this, smaller capacitances are successively switched to the reference voltage.
- 5) The sampling capacity of the conversion C-Network is pre-charged to $V_{AREF}/2$ before connecting the input to the C-Network. Because of the parasitic elements, the voltage measured at ANx is lower than $V_{AREF}/2$.

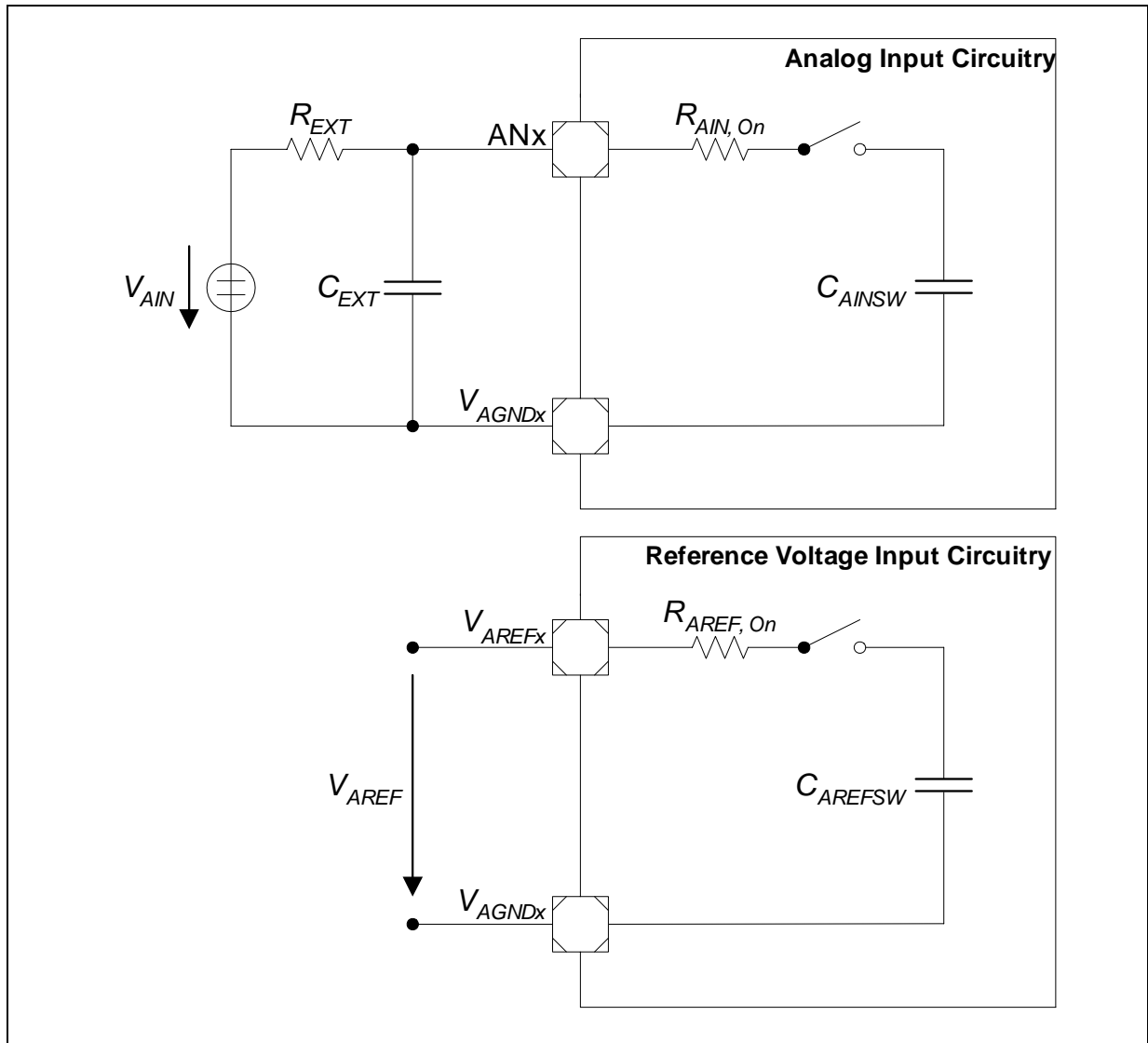

Figure 38 ADC Input Circuits

4.2.3.1 ADC Conversion Timing

Conversion time, $t_C = t_{ADC} \times (1 + r \times (3 + n + \text{STC}))$, where

$r = \text{CTC} + 2$ for $\text{CTC} = 00_{\text{B}}$, 01_{B} or 10_{B} ,

$r = 32$ for $\text{CTC} = 11_{\text{B}}$,

$\text{CTC} = \text{Conversion Time Control (GLOBCTR.CTC)}$,

$\text{STC} = \text{Sample Time Control (INPCR0.STC)}$,

$n = 8$ or 10 (for 8-bit and 10-bit conversion respectively),

$t_{ADC} = 1 / f_{ADC}$

4.2.4 Power Supply Current

Table 41 and **Table 42** provide the characteristics of the power supply current in the SAA-XC886.

**Table 41 Power Supply Current Parameters (Operating Conditions apply;
 $V_{DDP} = 5V$ range)**

Parameter	Symbol	Limit Values		Unit	Test Condition
		typ. ¹⁾	max. ²⁾		
$V_{DDP} = 5V$ Range					
Active Mode	I_{DDP}	26.9	31.9	mA	³⁾
Idle Mode	I_{DDP}	20.3	24.4	mA	⁴⁾
Active Mode with slow-down enabled	I_{DDP}	13.7	17.0	mA	⁵⁾
Idle Mode with slow-down enabled	I_{DDP}	11.4	14.2	mA	⁶⁾

1) The typical I_{DDP} values are periodically measured at $T_A = +25\text{ °C}$ and $V_{DDP} = 5.0\text{ V}$.

2) The maximum I_{DDP} values are measured under worst case conditions ($T_A = +140\text{ °C}$ and $V_{DDP} = 5.5\text{ V}$).

3) I_{DDP} (active mode) is measured with: CPU clock and input clock to all peripherals running at 24 MHz (set by on-chip oscillator of 9.6 MHz and NDIV in PLL_CON to 1001_B), $\overline{\text{RESET}} = V_{DDP}$, no load on ports.

4) I_{DDP} (idle mode) is measured with: CPU clock disabled, watchdog timer disabled, input clock to all peripherals enabled and running at 24 MHz, $\overline{\text{RESET}} = V_{DDP}$, no load on ports.

5) I_{DDP} (active mode with slow-down mode) is measured with: CPU clock and input clock to all peripherals running at 8 MHz by setting CLKREL in CMCON to 0110_B, $\overline{\text{RESET}} = V_{DDP}$, no load on ports.

6) I_{DDP} (idle mode with slow-down mode) is measured with: CPU clock disabled, watchdog timer disabled, input clock to all peripherals enabled and running at 8 MHz by setting CLKREL in CMCON to 0110_B, $\overline{\text{RESET}} = V_{DDP}$, no load on ports.

Electrical Parameters
Table 42 Power Down Current (Operating Conditions apply; $V_{DDP} = 5V$ range)

Parameter	Symbol	Limit Values		Unit	Test Condition
		typ. ¹⁾	max. ²⁾		
$V_{DDP} = 5V$ Range					
Power-Down Mode	I_{PDP}	1	10	μA	$T_A = + 25\text{ }^\circ C^{3)4)}$
		-	30	μA	$T_A = + 85\text{ }^\circ C^{4)5)}$

1) The typical I_{PDP} values are measured at $V_{DDP} = 5.0\text{ V}$.

2) The maximum I_{PDP} values are measured at $V_{DDP} = 5.5\text{ V}$.

3) I_{PDP} has a maximum value of $400\text{ }\mu A$ at $T_A = + 140\text{ }^\circ C$.

4) I_{PDP} is measured with: $\overline{RESET} = V_{DDP}$, $V_{AGND} = V_{SS}$, $RXD/INT0 = V_{DDP}$; rest of the ports are programmed to be input with either internal pull devices enabled or driven externally to ensure no floating inputs.

5) Not subjected to production test, verified by design/characterization.

4.3 AC Parameters

The electrical characteristics of the AC Parameters are detailed in this section.

4.3.1 Testing Waveforms

The testing waveforms for rise/fall time, output delay and output high impedance are shown in **Figure 39**, **Figure 40** and **Figure 41**.

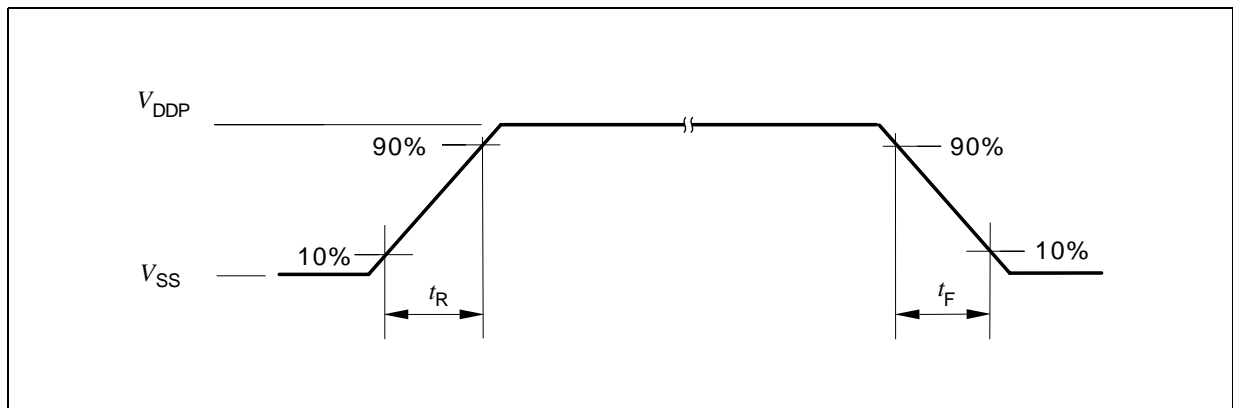

Figure 39 Rise/Fall Time Parameters

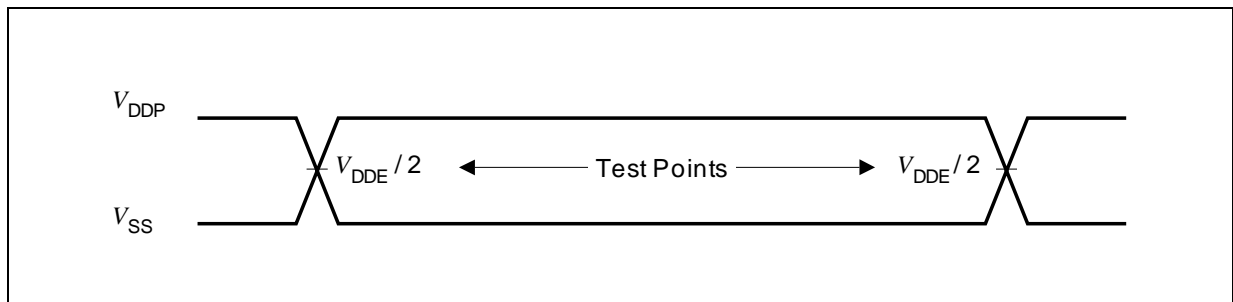

Figure 40 Testing Waveform, Output Delay

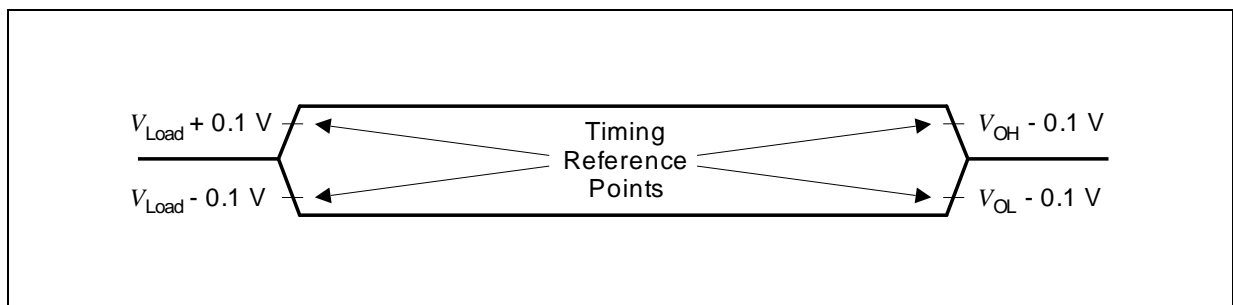

Figure 41 Testing Waveform, Output High Impedance

4.3.2 Output Rise/Fall Times

Table 43 provides the characteristics of the output rise/fall times in the SAA-XC886.

Table 43 Output Rise/Fall Times Parameters (Operating Conditions apply)

Parameter	Symbol	Limit Values		Unit	Test Conditions
		min.	max.		
$V_{DDP} = 5V$ Range					
Rise/fall times	t_R, t_F	–	10	ns	20 pF. ¹⁾²⁾³⁾

- 1) Rise/Fall time measurements are taken with 10% - 90% of pad supply.
- 2) Not all parameters are 100% tested, but are verified by design/characterization and test correlation.
- 3) Additional rise/fall time valid for $C_L = 20pF - 100pF @ 0.125 ns/pF$.

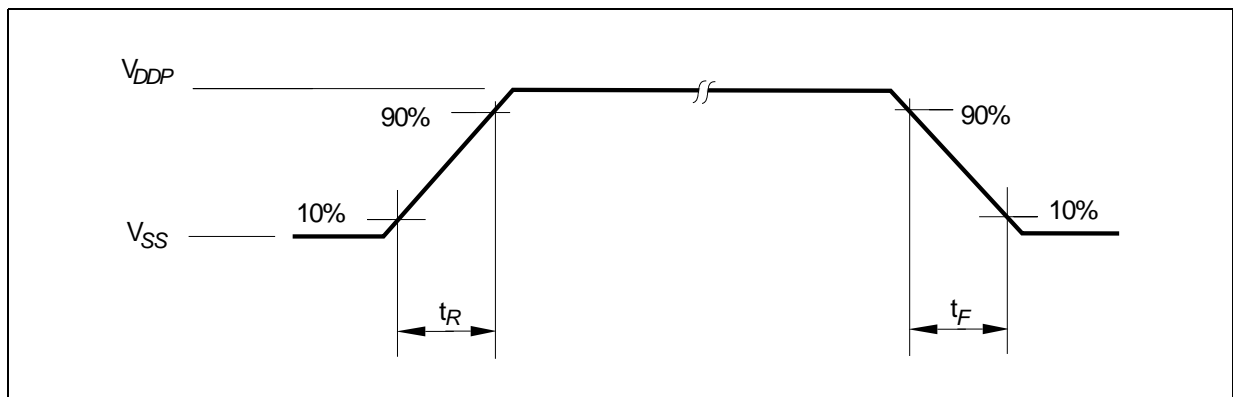

Figure 42 Rise/Fall Times Parameters

4.3.3 Power-on Reset and PLL Timing

Table 47 provides the characteristics of the power-on reset and PLL timing in the SAA-XC886.

Table 44 Power-On Reset and PLL Timing (Operating Conditions apply)

Parameter	Symbol		Limit Values			Unit	Test Conditions
			min.	typ.	max.		
Pad operating voltage	V_{PAD}	CC	2.3	–	–	V	1)
On-Chip Oscillator start-up time	t_{OSCST}	CC	–	–	500	ns	1)
Flash initialization time	t_{FINIT}	CC	–	160	–	μ s	1)
RESET hold time	t_{RST}	SR	–	500	–	μ s	V_{DDP} rise time (10% – 90%) \leq 500 μ s ¹⁾²⁾
PLL lock-in in time	t_{LOCK}	CC	–	–	200	μ s	1)
PLL accumulated jitter	D_P		–	–	0.7	ns	1)3)

1) Not all parameters are 100% tested, but are verified by design/characterization and test correlation.

2) RESET signal has to be active (low) until V_{DDC} has reached 90% of its maximum value (typ. 2.5 V).

3) PLL lock at 96 MHz using a 4 MHz external oscillator. The PLL Divider settings are K = 2, N = 48 and P = 1.

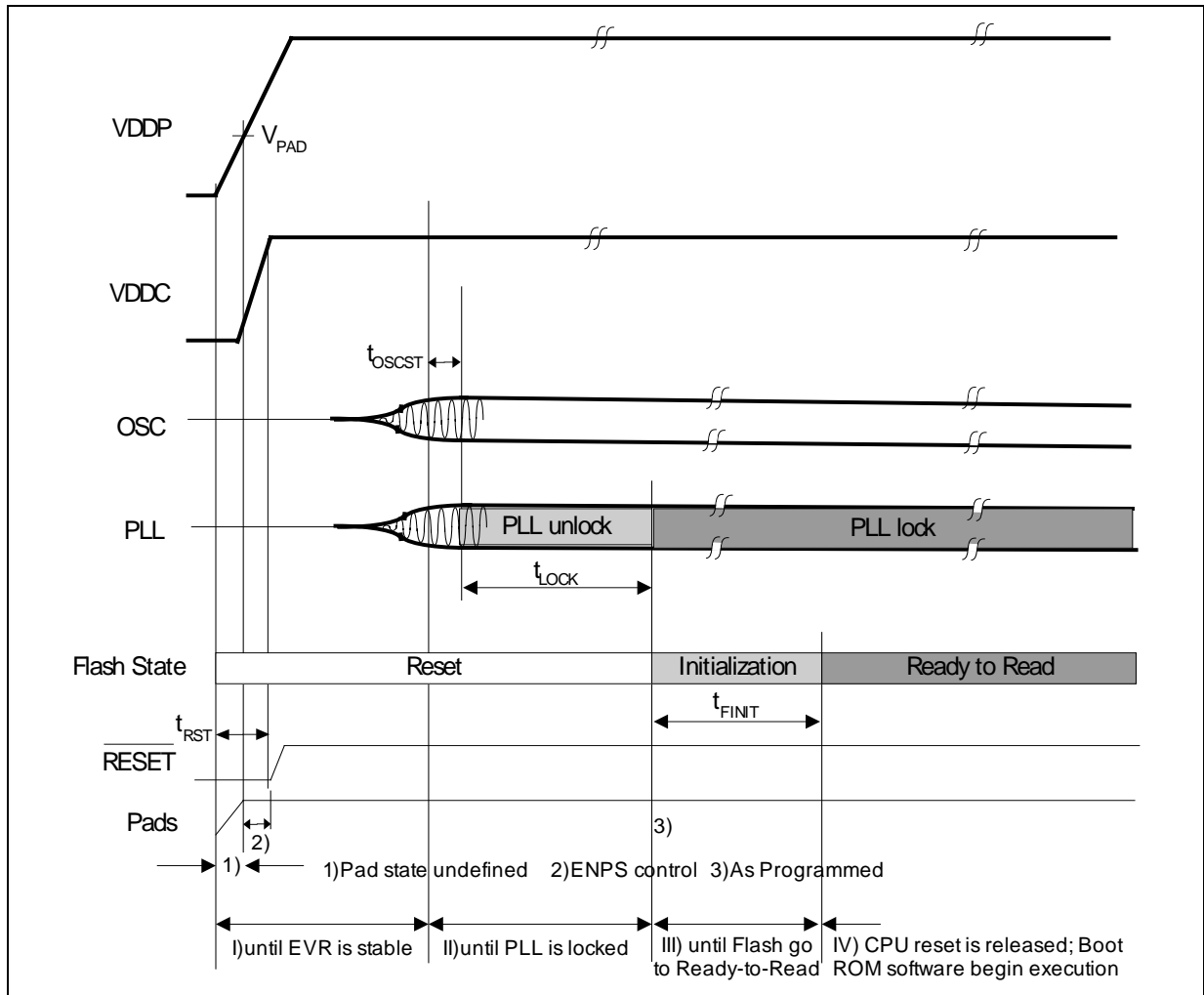

Figure 43 Power-on Reset Timing

4.3.4 On-Chip Oscillator Characteristics

Table 45 provides the characteristics of the on-chip oscillator in the SAA-XC886.

Table 45 On-chip Oscillator Characteristics (Operating Conditions apply)

Parameter	Symbol	Limit Values	Unit			Test Conditions
			min.	typ.	max.	
Nominal frequency	f_{NOM} CC	9.36	9.6	9.84	MHz	under nominal conditions ¹⁾
Long term frequency deviation	Δf_{LT} CC	0	–	6.0	%	with respect to f_{NOM} , over lifetime and temperature (125°C to 140°C), for one given device after trimming
		-5.0	–	5.0	%	with respect to f_{NOM} , over lifetime and temperature (-10°C to 125°C), for one given device after trimming
		-6.0	–	0	%	with respect to f_{NOM} , over lifetime and temperature (-40°C to -10°C), for one given device after trimming
Short term frequency deviation	Δf_{ST} CC	-1.0	–	1.0	%	within one LIN message (<10 ms 100 ms)

1) Nominal condition: $V_{\text{DDC}} = 2.5 \text{ V}$, $T_{\text{A}} = +25^\circ\text{C}$.

4.3.5 External Clock Drive XTAL1

Table 46 shows the parameters that define the external clock supply for SAA-XC886. These timing parameters are based on the direct XTAL1 drive of clock input signals. They are not applicable if an external crystal or ceramic resonator is considered.

Table 46 External Clock Drive Characteristics (Operating Conditions apply)

Parameter	Symbol	SR	Limit Values		Unit	Test Conditions
			Min.	Max.		
Oscillator period	t_{osc}	SR	83.3	250	ns	1)2)
High time	t_1	SR	25	-	ns	2)3)
Low time	t_2	SR	25	-	ns	2)3)
Rise time	t_3	SR	-	20	ns	2)3)
Fall time	t_4	SR	-	20	ns	2)3)

- 1) The clock input signals with 45-55% duty cycle are used.
- 2) Not all parameters are 100% tested, but are verified by design/characterization and test correlation.
- 3) The clock input signal must reach the defined levels V_{ILX} and V_{IHx} .

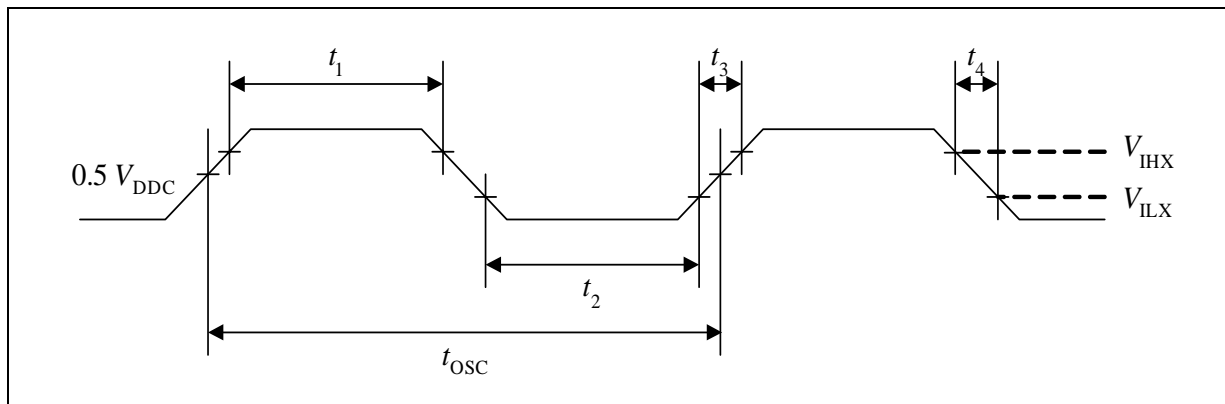

Figure 44 External Clock Drive XTAL1

4.3.6 JTAG Timing

Table 47 provides the characteristics of the JTAG timing in the SAA-XC886.

Table 47 TCK Clock Timing (Operating Conditions apply; CL = 50 pF)

Parameter	Symbol	Limits	Unit	Test Conditions	
					min
TCK clock period	t_{TCK} SR	50	-	ns	1)
TCK high time	t_1 SR	20	-	ns	1)
TCK low time	t_2 SR	20	-	ns	1)
TCK clock rise time	t_3 SR	-	4	ns	1)
TCK clock fall time	t_4 SR	-	4	ns	1)

1) Not all parameters are 100% tested, but are verified by design/characterization and test correlation.

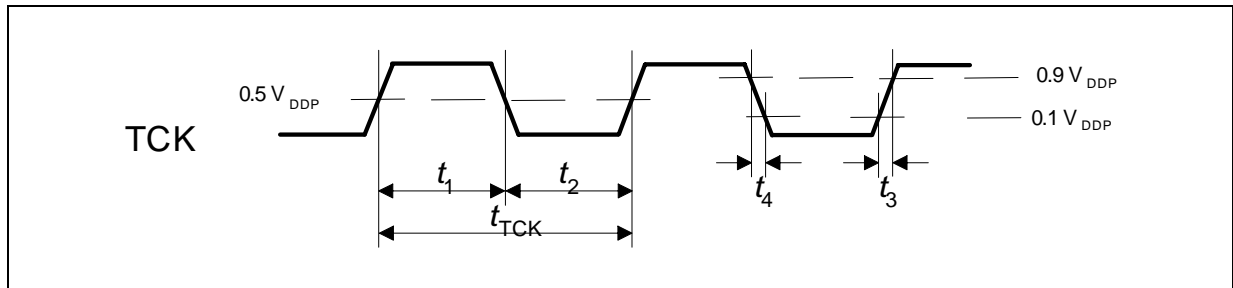





Figure 45 TCK Clock Timing

Table 48 JTAG Timing (Operating Conditions apply; CL = 50 pF)

Parameter	Symbol	Limits	Unit	Test Conditions	
					min
TMS setup to TCK 	t_1 SR	8	-	ns	1)
TMS hold to TCK 	t_2 SR	24	-	ns	1)
TDI setup to TCK 	t_1 SR	11	-	ns	1)
TDI hold to TCK 	t_2 SR	24	-	ns	1)
TDO valid output from TCK	t_3 CC	-	27	ns	1)

Electrical Parameters

Table 48 JTAG Timing (Operating Conditions apply; CL = 50 pF) (cont'd)

Parameter	Symbol	Limits		Unit	Test Conditions
		min	max		
TDO high impedance to valid output from TCK	t_4 CC	-	35	ns	1)
TDO valid output to high impedance from TCK	t_5 CC	-	27	ns	1)

1) Not all parameters are 100% tested, but are verified by design/characterization and test correlation.

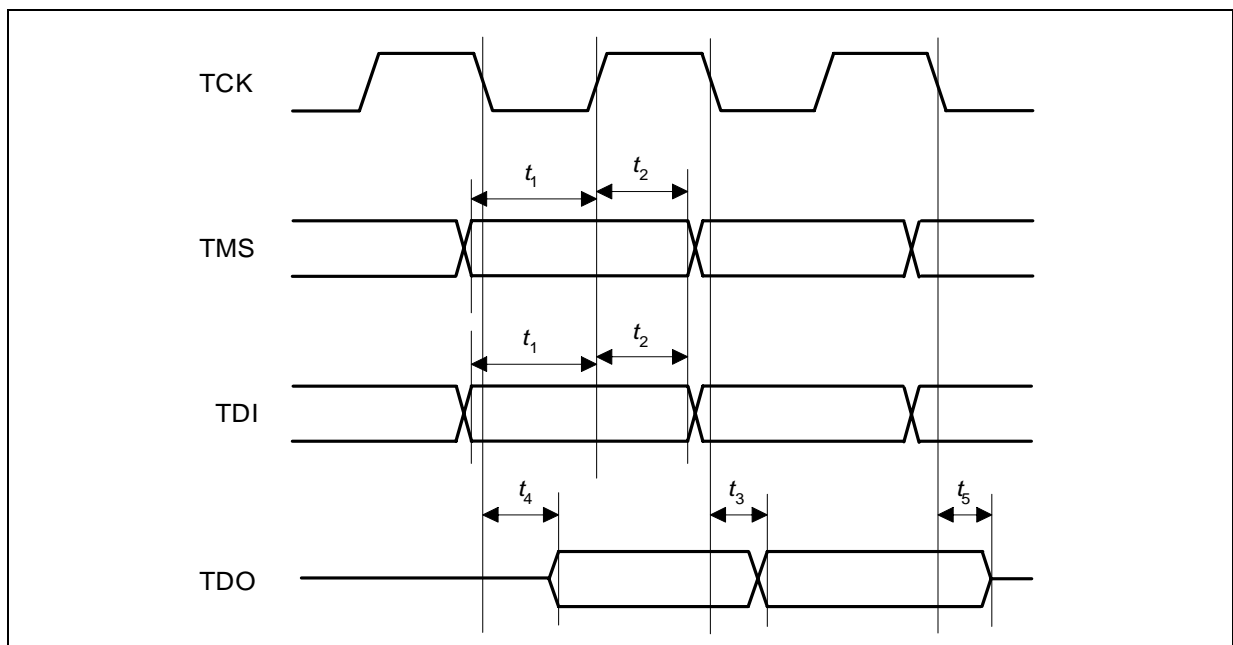

Figure 46 JTAG Timing

4.3.7 SSC Master Mode Timing

Table 49 provides the characteristics of the SSC timing in the SAA-XC886.

Table 49 SSC Master Mode Timing (Operating Conditions apply; CL = 50 pF)

Parameter	Symbol	CC	Limit Values		Unit	Test Conditions
			min.	max.		
SCLK clock period	t_0	CC	$2 \cdot T_{SSC}$	–	ns	1)2)
MSTR delay from SCLK	t_1	CC	0	8	ns	2)
MRST setup to SCLK	t_2	SR	24	–	ns	2)
MRST hold from SCLK	t_3	SR	0	–	ns	2)

- 1) $T_{SSCmin} = T_{CPU} = 1/f_{CPU}$. When $f_{CPU} = 24$ MHz, $t_0 = 83.3$ ns. T_{CPU} is the CPU clock period.
- 2) Not all parameters are 100% tested, but are verified by design/characterization and test correlation.

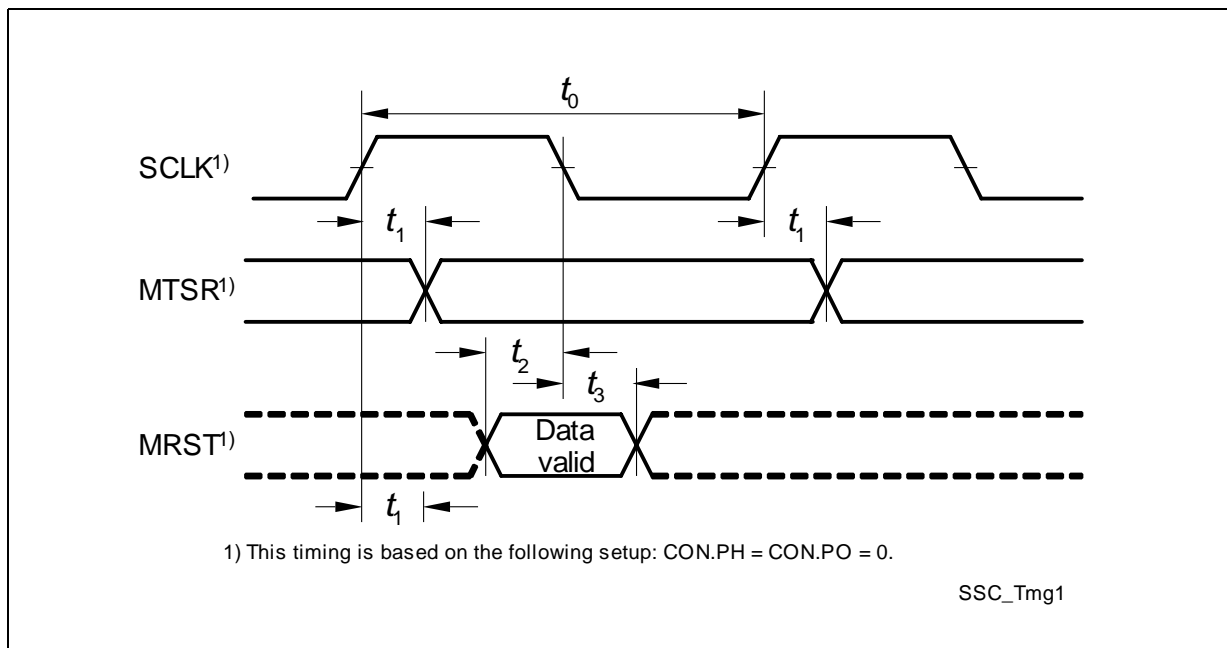

Figure 47 SSC Master Mode Timing

5 Package and Quality Declaration

Chapter 5 provides the information of the SAA-XC886 package and reliability section.

5.1 Package Parameters

Table 50 provides the thermal characteristics of the package used in SAA-XC886.

Table 50 Thermal Characteristics of the Packages

Parameter	Symbol		Limit Values		Unit	Notes
			Min.	Max.		
PG-TQFP-48						
Thermal resistance junction case	R_{TJC}	CC	-	11.6	K/W	1)2)
Thermal resistance junction lead	R_{TJL}	CC	-	33.2	K/W	1)2)

1) The thermal resistances between the case and the ambient (R_{TCA}), the lead and the ambient (R_{TLA}) are to be combined with the thermal resistances between the junction and the case (R_{TJC}), the junction and the lead (R_{TJL}) given above, in order to calculate the total thermal resistance between the junction and the ambient (R_{TJA}). The thermal resistances between the case and the ambient (R_{TCA}), the lead and the ambient (R_{TLA}) depend on the external system (PCB, case) characteristics, and are under user responsibility.

The junction temperature can be calculated using the following equation: $T_J = T_A + R_{TJA} \times P_D$, where the R_{TJA} is the total thermal resistance between the junction and the ambient. This total junction ambient resistance R_{TJA} can be obtained from the upper four partial thermal resistances, by

- a) simply adding only the two thermal resistances (junction lead and lead ambient), or
- b) by taking all four resistances into account, depending on the precision needed.

2) Not all parameters are 100% tested, but are verified by design/characterization and test correlation.

5.2 Package Outline

Figure 48 shows the package outlines of the SAA-XC886.

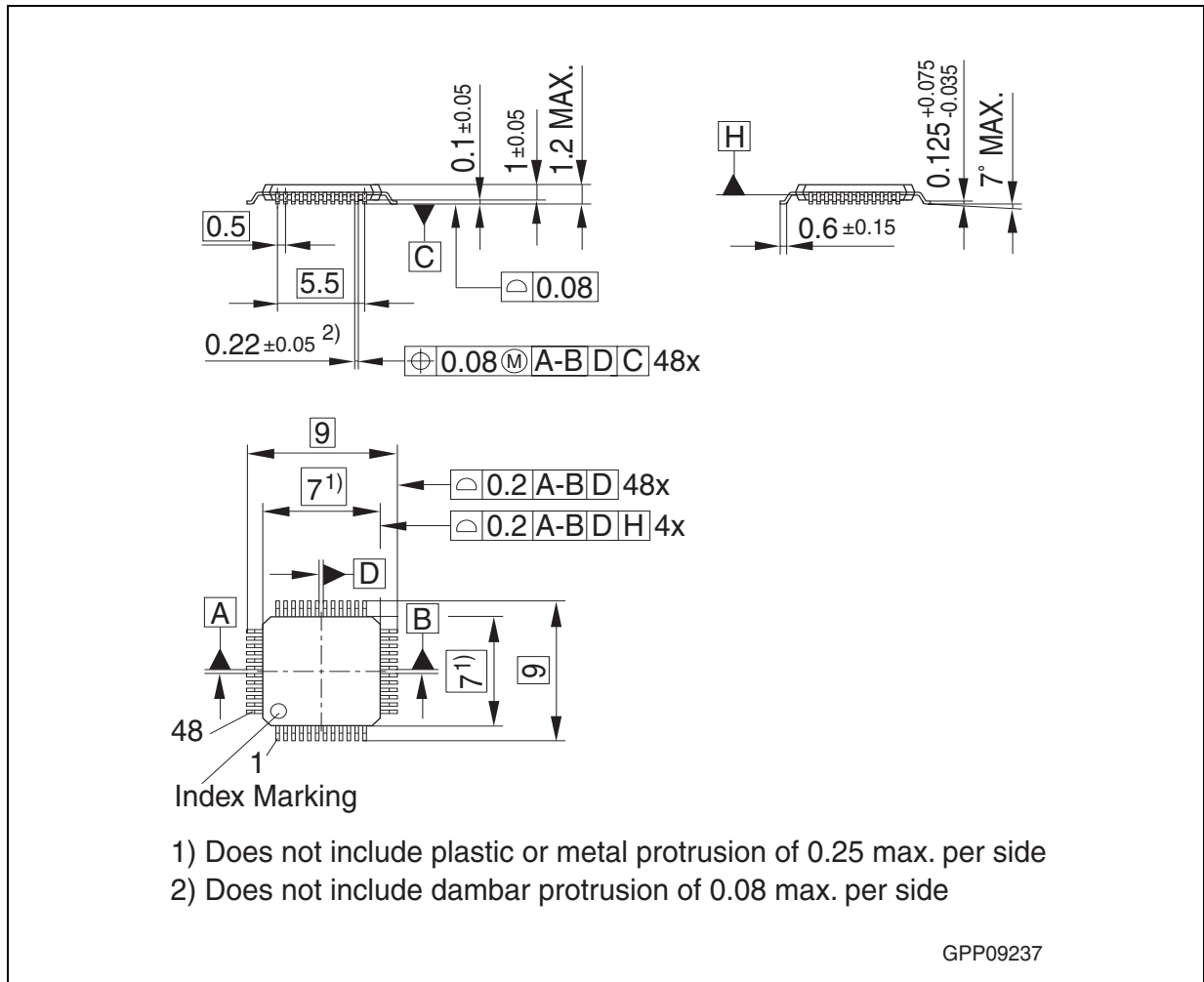

Figure 48 PG-TQFP-48 Package Outline

5.3 Quality Declaration

Table 51 shows the characteristics of the quality parameters in the SAA-XC886.

Table 51 Quality Parameters

Parameter	Symbol	Limit Values			Unit	Notes
		Min.	Typ.	Max.		
Operation Lifetime when the device is used at the four stated T_A ¹⁾	t_{OP}	-	-	1500	hours	$T_A = 140^\circ\text{C}^{2)}$
		-	-	2000	hours	$T_A = 125^\circ\text{C}^{2)}$
		-	-	10000	hours	$T_A = 85^\circ\text{C}^{2)}$
		-	-	1500	hours	$T_A = -40^\circ\text{C}^{2)}$
Operation Lifetime when the device is used at the two stated T_A ¹⁾	t_{OP2}	-	-	18000	hours	$T_A = 108^\circ\text{C}^{2)}$
		-	-	130000	hours	$T_A = 27^\circ\text{C}^{2)}$
Weighted Average Temperature ³⁾	T_{WA}	-	106	-	°C	For 15000 hours ²⁾
ESD susceptibility according to Human Body Model (HBM) for all pins	V_{HBM}	-	-	2000	V	Conforming to EIA/JESD22-A114-B ²⁾
ESD susceptibility according to Charged Device Model (CDM) pins	V_{CDM}	-	-	750	V	Conforming to JESD22-C101-C ²⁾

1) This lifetime refers only to the time when the device is powered-on.

2) Not all parameters are 100% tested, but are verified by design/characterization and test correlation.

3) This parameter is derived based on the Arrhenius model.

www.infineon.com

Published by Infineon Technologies AG