

### Analog Peripherals

#### Two 16-Bit ADCs

- $\pm 1.5$  LSB INL; guaranteed no missing codes
- Programmable throughput up to 1 Msps (each ADC)
- Configurable as two single-ended or one differential ADC
- DMA to XRAM or external memory interface
- Data-dependent windowed interrupt generator

#### 10-Bit ADC

- Programmable throughput up to 200 ksps
- 8 external inputs
- Built-in temperature sensor ( $\pm 3$  °C)

#### Two 12-Bit DACs

- Can synchronize outputs to timers for jitter-free waveform generation

#### Three Comparators

#### Internal Voltage Reference

#### Precision $V_{DD}$ Monitor/Brown-out Detector

#### On-Chip JTAG Debug & Boundary Scan

- On-chip debug circuitry facilitates full speed, non-intrusive in-system debug (no emulator required)
- Provides breakpoints, single stepping, watchpoints, stack monitor
- Inspect/modify memory and registers
- Superior performance to emulation systems using ICE-chips, target pods, and sockets
- IEEE1149.1 compliant boundary scan

#### Supply Voltage: 2.7 to 3.6 V

- Typical operating current: 10 mA at 25 MHz
- Multiple power saving sleep and shutdown modes

### High-Speed 8051 $\mu$ C Core

- Pipelined instruction architecture; executes 70% of instructions in 1 or 2 system clocks
- Up to 25 MIPS throughput with 25 MHz system clock
- Expanded interrupt handler

### Memory

- 4352 bytes data RAM
- 64 kB Flash; in-system programmable in 1024-byte sectors (1024 bytes are reserved)
- External parallel data memory interface

### CAN Bus 2.0B

- 32 message objects
- "Mailbox" implementation only interrupts CPU when needed

### Digital Peripherals

- 24 port I/O; all are 5 V tolerant
- Hardware SMBus™ (I2C™ compatible), SPI™, and two UART serial ports available concurrently
- Programmable 16-bit counter array with 6 capture/compare modules
- 5 general-purpose 16-bit counter/timers
- Dedicated watchdog timer; bidirectional reset
- Real-time clock mode using timers or PCA

### Clock Sources

- Internal programmable 2% oscillator: up to 24.5 MHz
- External oscillator: Crystal, RC, C, or Clock

### 64-Pin TQFP

- Temperature Range:  $-40$  to  $+85$  °C

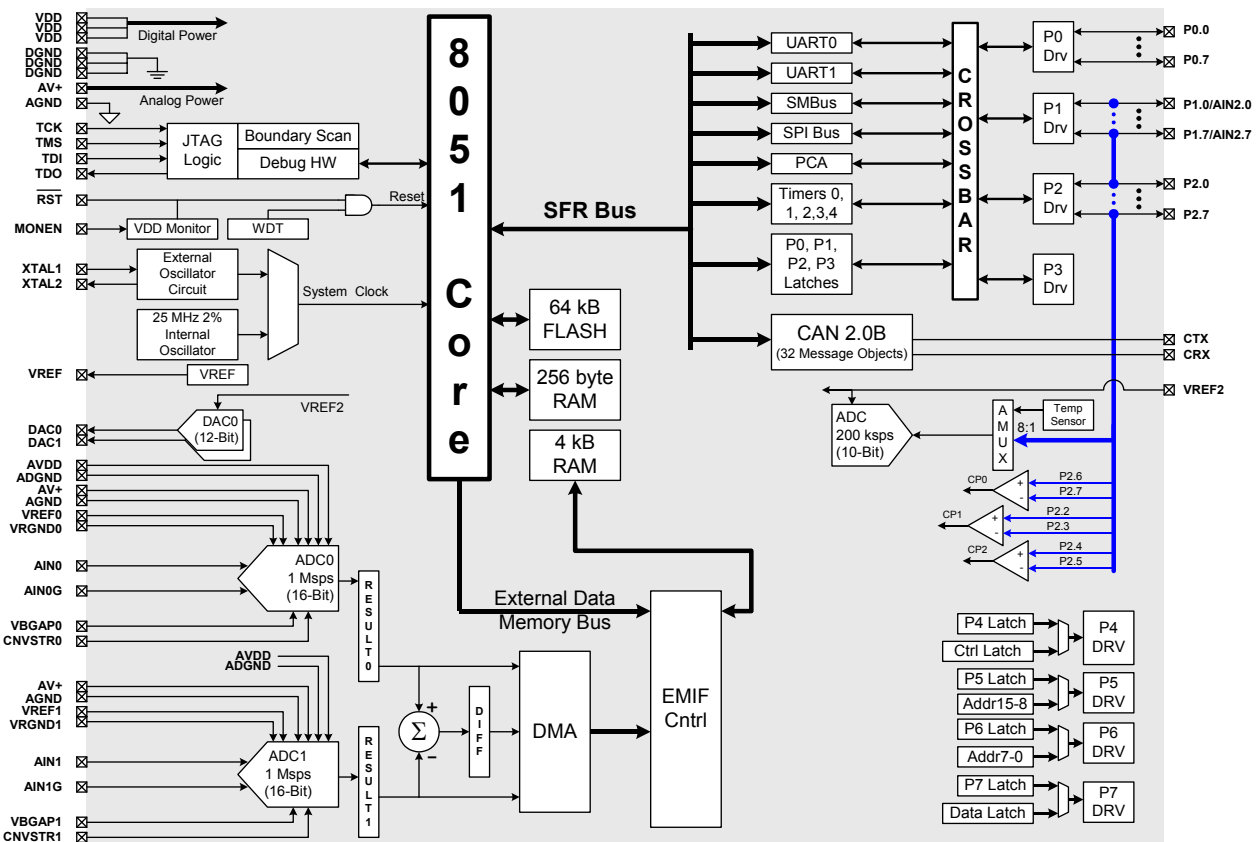

### Selected Electrical Specifications

( $T_A = -40$  to  $+85$  °C,  $V_{DD} = 2.7$  V unless otherwise specified)

PARAMETER	CONDITIONS	MIN	TYP	MAX	UNITS
<b>GLOBAL CHARACTERISTICS</b>					
Supply Voltage		2.7		3.6	V
Supply Current (CPU active)	Clock = 25 MHz		18		mA
	Clock = 1 MHz		0.7		mA
	Clock = 32 kHz; $V_{DD}$ Monitor Enabled		20		$\mu$ A
Supply Current (shutdown)	Oscillator not running; $V_{DD}$ Monitor Disabled		0.1		$\mu$ A
Clock Frequency Range		DC		25	MHz
<b>16-BIT A/D CONVERTERS</b>					
Resolution			16		bits
Integral Nonlinearity	Single-ended Mode		$\pm 1.5$	$\pm 4$	LSB
	Differential Mode		$\pm 1$	$\pm 2$	LSB
Differential Nonlinearity	Guaranteed Monotonic		$\pm 0.5$	$\pm 1$	LSB
Signal-to-Noise Plus Distortion	$F_{in} = 10$ kHz, Single-ended		86		dB
	$F_{in} = 10$ kHz, Differential		89		dB
Total Harmonic Distortion	$F_{in} = 10$ kHz, Single-ended		96		dB
	$F_{in} = 10$ kHz, Differential		103		dB
Spurious-Free Dynamic Range	$F_{in} = 10$ kHz, Single-ended		97		dB
	$F_{in} = 10$ kHz, Differential		104		dB
Throughput Rate				1	Msp/s
Input Voltage Range	Single-ended (AINn–AINnG)	0		$V_{REF}$	V
	Differential (AIN0–AIN1)	$-V_{REF}$		$V_{REF}$	V
Power Supply Current (each ADC)	Operating Mode, 1 Msp/s (AVDD + AV+)		5.5		mA
	Shutdown Mode		1		$\mu$ A
<b>D/A CONVERTERS</b>					
Resolution			12		LSB
Differential Nonlinearity				$\pm 1$	LSB
Output Settling Time			10		$\mu$ s

### Package Information

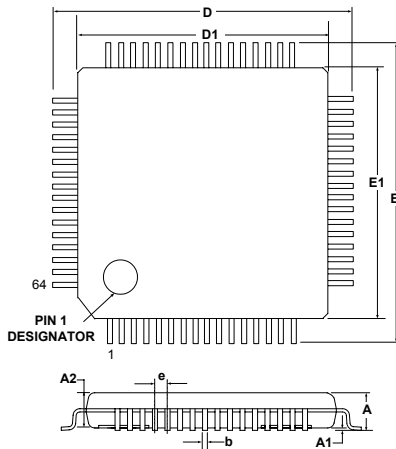

	MIN (mm)	NOM (mm)	MAX (mm)
A	-	-	1.20
A1	0.05	-	0.15
A2	0.95	-	1.05
b	0.17	0.22	0.27
D	-	12.00	-
D1	-	10.00	-
e	-	0.50	-
E	-	12.00	-
E1	-	10.00	-

### C8051F060DK Development Kit

