

Analog Peripherals

8-Bit ADC

- ± 1 LSB INL; no missing codes
- Programmable throughput up to 500 ksps
- Up to 8 external inputs; programmable as single-ended or differential
- Programmable amplifier gain: 4, 2, 1, 0.5
- V_{REF} from external pin or V_{DD}
- Internal or external start of conversion sources
- Data-dependent windowed interrupt generator
- Built-in temperature sensor (± 3 °C)

Comparator

- Programmable hysteresis and response time
- Configurable to generate interrupts or reset
- Low current (0.4 μ A)

POR/Brown-Out Detector

On-Chip Debug

- On-chip debug circuitry facilitates full speed, non-intrusive in-system debug (no emulator required)
- Provides breakpoints, single stepping, watchpoints
- Inspect/modify memory, registers, and stack
- Superior performance to emulation systems using ICE-chips, target pods, and sockets

Supply Voltage: 2.7 to 3.6 V

- Typical operating current: 5.8 mA at 25 MHz
11 μ A at 32 kHz
- Typical stop mode current: <0.1 μ A

Temperature Range: -40 to +85 °C

High-Speed 8051 μ C Core

- Pipelined instruction architecture; executes 70% of instructions in 1 or 2 system clocks
- Up to 25 MIPS throughput with 25 MHz clock
- Expanded interrupt handler

Memory

- 256 bytes data RAM
- 8 kB Flash; in-system programmable in 512 byte sectors (512 bytes are reserved)

Digital Peripherals

- 8 port I/O; all are 5 V tolerant
- Enhanced Hardware SMBus™ (I2C™ compatible) and UART serial ports
- Programmable 16-bit counter/timer array with three capture/compare modules, WDT
- 3 general-purpose 16-bit counter/timers
- Dedicated watchdog timer; bidirectional reset
- Real-time clock mode using PCA or timer and external clock source

Clock Sources

- Internal oscillator: 20 MHz nominal
- External oscillator: Crystal, RC, C, or Clock (1 or 2 Pin Modes)
- Can switch between clock sources on-the-fly

Package

- 11-pin QFN
- 14-pin SOIC

Ordering Part Numbers

- Lead-free package: C8051F302-GM (QFN)
- Lead-free package: C8051F302-GS (SOIC)

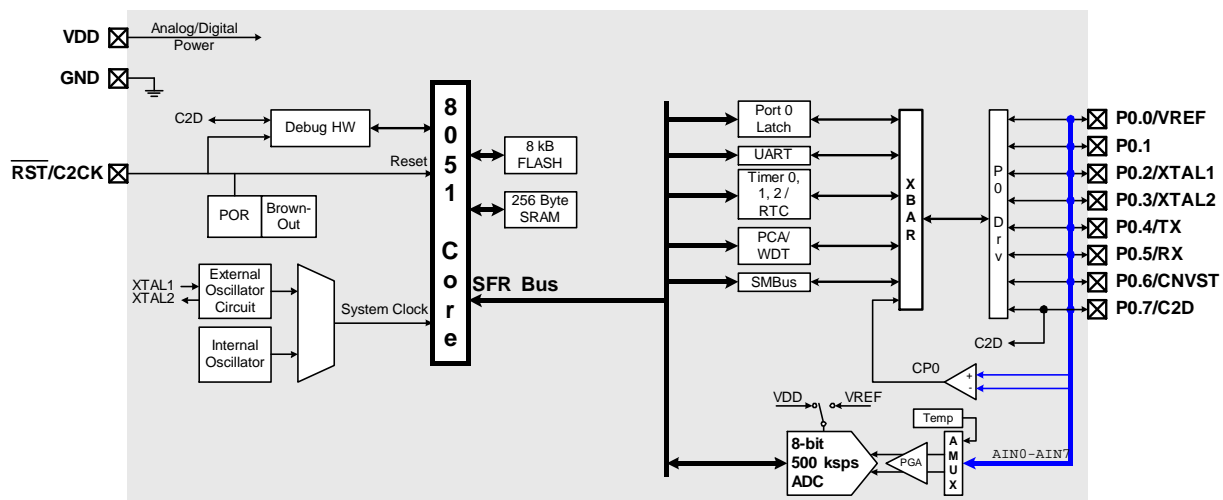

Selected Electrical Specifications

($T_A = -40$ to $+85$ °C, $V_{DD} = 2.7$ V unless otherwise specified)

PARAMETER	CONDITIONS	MIN	TYP	MAX	UNITS
GLOBAL CHARACTERISTICS					
Supply Voltage		2.7		3.6	V
Supply Current with CPU active	Clock = 25 MHz		5.8		mA
	Clock = 1 MHz		0.34		mA
	Clock = 32 kHz; V_{DD} Monitor Disabled		11		μ A
Supply Current (shutdown)	Oscillator off; V_{DD} Monitor Enabled		10		μ A
	Oscillator off; V_{DD} Monitor Disabled		<0.1		μ A
CPU & DIGITAL I/O PORTS					
Clock Frequency Range		DC		25	MHz
Port Output High Voltage	$I_{OH} = -3$ mA, Port I/O push-pull	V_{DD}			V
Port Output Low Voltage	$I_{OL} = 8.5$ mA	V_{DD}		0.6	V
Input High Voltage		$0.7 \times V_{DD}$			V
Input Low Voltage				$0.3 \times V_{DD}$	V
INTERNAL OSCILLATOR					
Frequency		15.0	20.0	25.0	MHz
A/D CONVERTER					
Resolution			8		bits
Integral Nonlinearity			$\pm\frac{1}{2}$	± 1	LSB
Differential Nonlinearity	Guaranteed Monotonic		$\pm\frac{1}{2}$	± 1	LSB
Signal-to-Noise Plus Distortion		49			dB
Throughput Rate				500	ksps
Input Voltage Range		0		V_{REF}	V
COMPARATOR					
Response Time Mode0	$(CP+) - (CP-) = 100$ mV		0.1		μ s
Current Consumption Mode0			7.6		μ A
Response Time Mode1	$(CP+) - (CP-) = 100$ mV		0.18		μ s
Current Consumption Mode1			3.2		μ A
Response Time Mode2	$(CP+) - (CP-) = 100$ mV		0.32		μ s
Current Consumption Mode2			1.3		μ A
Response Time Mode3	$(CP+) - (CP-) = 100$ mV		1		μ s
Current Consumption Mode3			0.4		μ A

Package Information

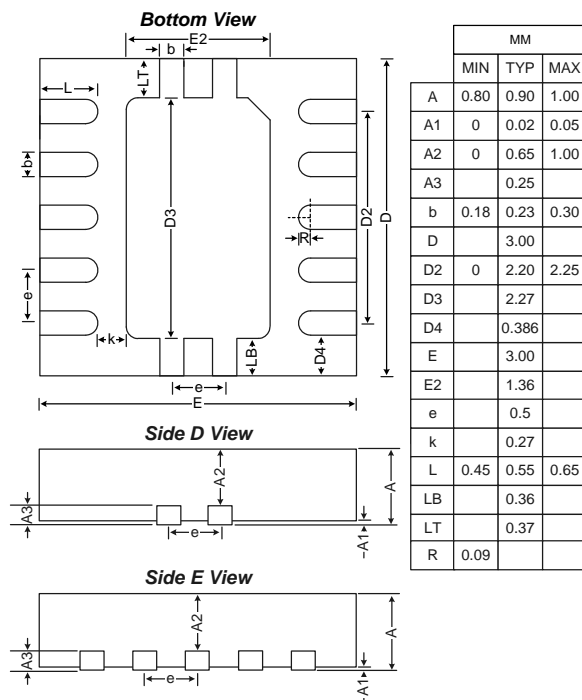

C8051F300DK Development Kit

