

Analog Peripherals

10-Bit ADC

- ± 1 LSB INL; no missing codes
- Programmable throughput up to 100 ksp/s
- 8 external inputs; programmable as single-ended or differential
- Data-dependent windowed interrupt generator
- Built-in temperature sensor (± 3 °C)

Two Comparators

- 16 programmable hysteresis values
- Configurable to generate interrupts or reset

Internal Voltage Reference

V_{DD} Monitor/Brown-out Detector

On-Chip JTAG Debug & Boundary Scan

- On-chip debug circuitry facilitates full speed, non-intrusive in-system debug (no emulator required)
- Provides breakpoints, single stepping, watchpoints, stack monitor
- Inspect/modify memory and registers
- Superior performance to emulation systems using ICE-chips, target pods, and sockets
- IEEE1149.1 compliant boundary scan

High-Speed 8051 μ C Core

- Pipelined instruction architecture; executes 70% of instructions in 1 or 2 system clocks
- Up to 25 MIPS throughput with 25 MHz system clock
- Expanded interrupt handler

Memory

- 1280 bytes data RAM
- 16 kB Flash; in system programmable in 512-byte sectors (512 bytes are reserved)

Digital Peripherals

- 16 port I/O; all are 5 V tolerant
- Hardware SMBus™ (I2C™ compatible), SPI™, and UART serial ports available concurrently
- Programmable 16-bit counter/timer array with five capture/compare modules
- 4 general-purpose 16-bit counter/timers
- Dedicated watchdog timer; bidirectional reset

Clock Sources

- Internal programmable oscillator: 2–16 MHz
- External oscillator: Crystal, RC, C, or Clock
- Can switch between clock sources on-the-fly

Supply Voltage: 2.8 to 3.6 V

- Typical operating current: 12.5 mA at 25 MHz
- Multiple power saving sleep and shutdown modes

48-Pin TQFP

Temperature Range: -40 to $+85$ °C

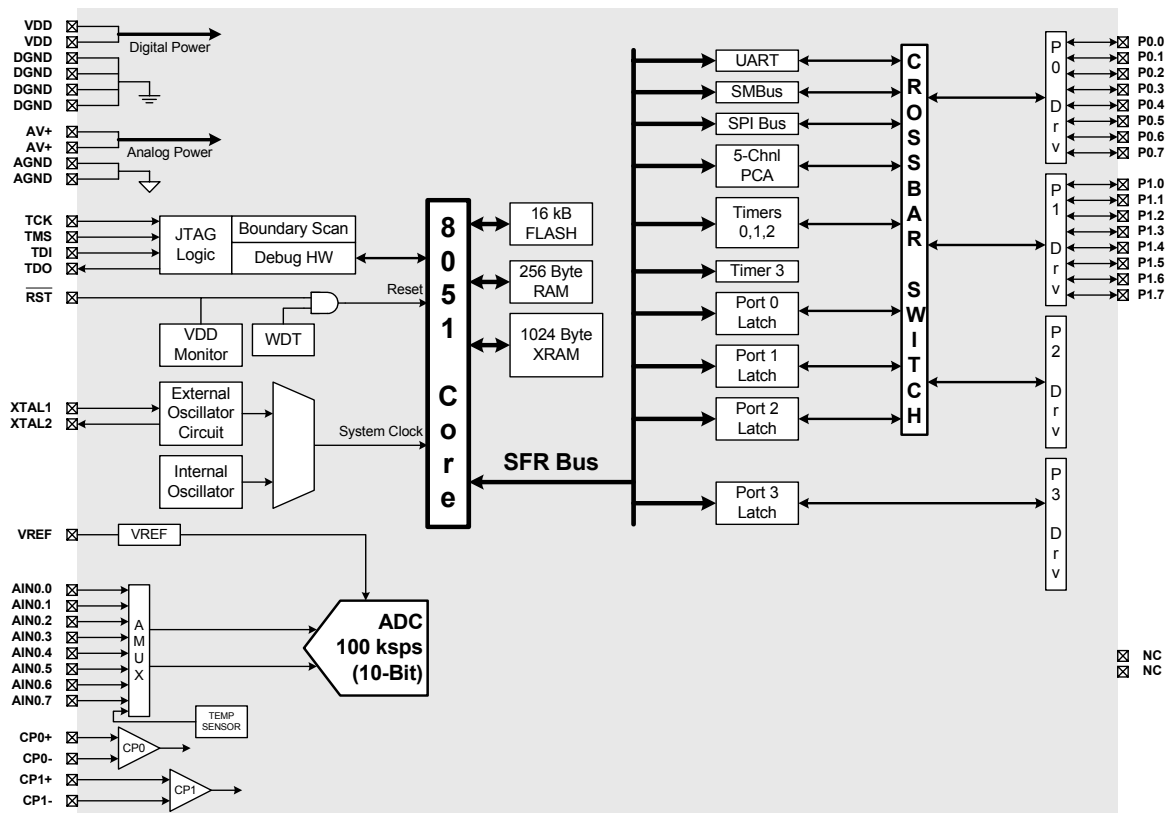

Selected Electrical Specifications

($T_A = -40$ to $+85$ °C, $V_{DD} = 2.8$ V unless otherwise specified)

PARAMETER	CONDITIONS	MIN	TYP	MAX	UNITS
GLOBAL CHARACTERISTICS					
Supply Voltage		2.8		3.6	V
Supply Current (CPU active)	Clock = 25 MHz Clock = 1 MHz Clock = 32 kHz		12.5 0.5 20		mA mA μA
Supply Current (shutdown)	Oscillator not running		10		μA
Clock Frequency Range		DC		25	MHz
A/D CONVERTER					
Resolution			10		bits
Integral Nonlinearity			±½	±1	LSB
Differential Nonlinearity	Guaranteed Monotonic		±½	±1	LSB
Signal-to-Noise Plus Distortion		59	61		dB
Throughput Rate				100	ksps
Input Voltage Range		0		V_{REF}	V
COMPARATORS					
Supply Current	(each comparator)		1.5		μA
Response Time	(CP+) – (CP-) = 100 mV		4		μs

Package Information

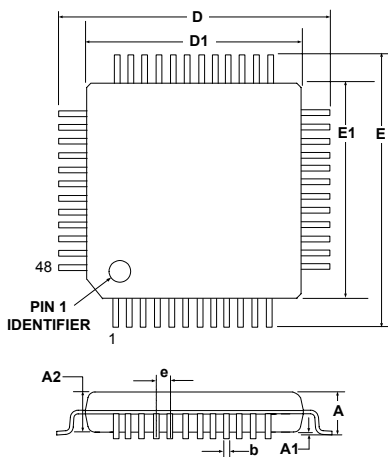

	MIN (mm)	NOM (mm)	MAX (mm)
A	-	-	1.20
A1	0.05	-	0.15
A2	0.95	1.00	1.05
b	0.17	0.22	0.27
D	-	9.00	-
D1	-	7.00	-
e	-	0.50	-
E	-	9.00	-
E1	-	7.00	-

C8051F005DK Development Kit

