

Product Brief

MPC555PB/D
Rev. 3, 2/2003

MPC555 Product Brief

This document provides an overview of the MPC555 microcontroller, including a block diagram showing the major modular components and sections that list the major features. The MPC555 member of the Freescale MPC500 RISC Microcontroller family.

Table 1. MPC555 Features

Device	Flash	Code Compression
MPC555	448 Kbytes	Code compression not supported

1 Introduction

The MPC555 device offers the following features:

- PowerPC™ core with floating-point unit
- 26 Kbytes fast RAM and 6 Kbytes TPU microcode RAM
- 448 Kbytes Flash EEPROM with 5-V programming
- 5-V I/O system
- Serial system: queued serial multi-channel module (QSMCM), dual CAN 2.0B controller modules (TouCAN™)
- 50-channel timer system: dual time processor units (TPU3), modular I/O system (MIOS1)
- 32 analog inputs: dual queued analog-to-digital converters (QADC64)
- Submicron HCMOS (CDR1) technology
- 272-pin plastic ball grid array (PBGA) packaging
- 40-MHz operation, -40 °C to 125 °C with dual supply (3.3 V, 5 V) (-55 °C to 125 °C for the suffix A device)
- 32-bit architecture (PowerPC ISA architecture compliant)
- Core performance measured at 52.7-Kbyte Dhrystones (v2.1) @ 40 MHz
- Fully static, low power operation
- Integrated double-precision floating-point unit
- Precise exception model

Block Diagram

- Extensive system development support
 - On-chip watchpoints and breakpoints
 - Program flow tracking
 - BDM on-chip emulation development interface

1.1 Block Diagram

Figure 1 is a block diagram of the MPC555.

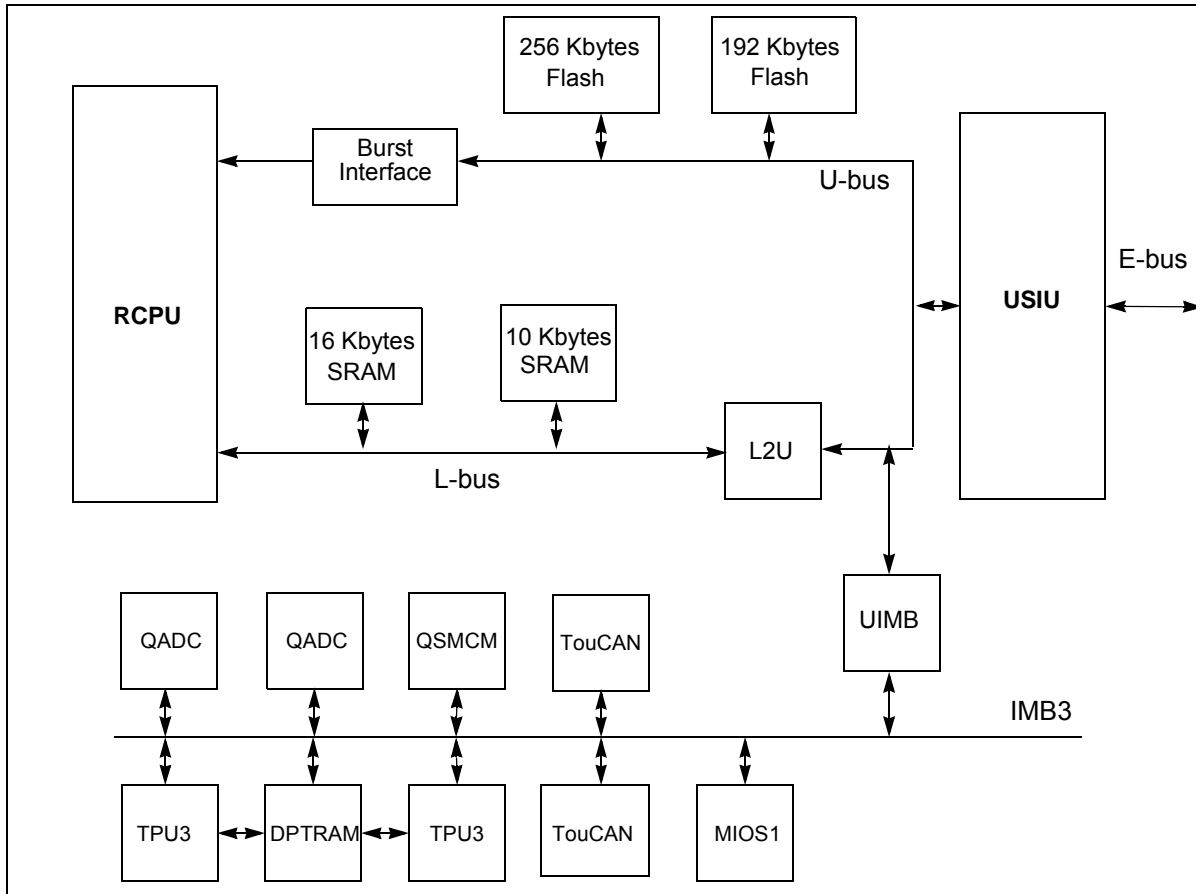

Figure 1. MPC555 Block Diagram

1.2 Key Features

The MPC555 key features are explained in the following sections.

1.2.1 Four-Bank Memory Controller

- Works with SRAM, EPROM, Flash EEPROM, and other peripherals
- Byte write enables
- 32-bit address decodes with bit masks

1.2.2 U-Bus System Interface Unit (USIU)

- Clock synthesizer
- Power management
- Reset controller
- MPC555 decremter and time base
- Real-time clock register
- Periodic interrupt timer
- Hardware bus monitor and software watchdog timer
- Interrupt controller that supports up to eight external and eight internal interrupts
- IEEE 1149.1 JTAG test access port
- External bus interface
 - 24 address pins, 32 data pins
 - Supports multiple master designs
 - Four-beat transfer bursts, two-clock minimum bus transactions
 - Supports 5V inputs, provides 3.3-V outputs

1.2.3 Flexible Memory Protection Unit

- Four instruction regions and four data regions
- 4-Kbyte to 16-Mbyte region size support
- Default attributes available in one global entry
- Attribute support for speculative accesses

1.2.4 448-Kbyte Flash EEPROM Memory

- One 256-Kbyte and one 192-Kbyte module
- Page read mode
- Block (32-Kbyte) erasable
- External 4.75-V to 5.25-V program and erase power supply

1.2.5 26-Kbytes of Static RAM

- One 16-Kbyte and one 10-Kbyte module
- Fast (one-clock) access
- Keep-alive power
- Soft defect detection (SDD)

1.2.6 General-Purpose I/O Support

- Address (24) and data (32) pins can be used for general-purpose I/O in single-chip mode
- Nine general-purpose I/O pins in MIOS1 unit
- Many peripheral pins can be used for general-purpose I/O when not used for primary function
- 5-V tolerant inputs/outputs

1.2.7 Two Time Processor Units (TPU3)

- Each TPU3 module provides these features:
 - A dedicated micro-engine operates independently of the RCPU
 - 16 independent programmable channels and pins
 - Each channel has an event register consisting of a 16-bit capture register, a 16-bit compare register and a 16-bit comparator
 - Nine pre-programmed timer functions are available
 - Any channel can perform any time function
 - Each timer function can be assigned to more than one channel
 - Two timer count registers with programmable prescalers
 - Each channel can be synchronized to one or both counters
 - Selectable channel priority levels
 - 5-V tolerant inputs/outputs
- 6-Kbyte dual port TPU RAM (DPTRAM) is shared by the two TPU3 modules for TPU microcode

1.2.8 18-Channel Modular I/O System (MIOS1)

- Ten double action submodules (DASM)
- Eight dedicated PWM sub-modules (PWMSM)
- Two 16-bit modulus counter submodules (MCSM)
- Two parallel port I/O submodules (PIOSM)
- 5-V tolerant inputs/outputs

1.2.9 Two Queued Analog-to-Digital Converter Modules (QADC64)

Each QADC provides:

- Up to 16 analog input channels, using internal multiplexing
- Up to 41 total input channels, using internal and external multiplexing
- 10-bit A/D converter with internal sample/hold
- Typical conversion time of 10 μ s (100,000 samples per second)
- Two conversion command queues of variable length
- Automated queue modes initiated by:
 - External edge trigger/level gate
 - Software command
- 64 result registers
- Output data that is right- or left-justified, signed or unsigned
- 5-V reference and range

1.2.10 Two CAN 2.0B Controller Modules (TouCAN)

Each TouCAN provides these features:

- Full implementation of CAN protocol specification, version 2.0A and 2.0B
- Each module has 16 receive/transmit message buffers of 0 to 8 bytes data length
- Global mask register for message buffers 0 to 13
- Independent mask registers for message buffers 14 and 15
- Programmable transmit-first scheme: lowest ID or lowest buffer number
- 16-bit free-running timer for message time-stamping
- Low power sleep mode with programmable wake-up on bus activity
- Programmable I/O modes
- Maskable interrupts
- Independent of the transmission medium (external transceiver is assumed)
- Open network architecture
- Multimaster concept
- High immunity to EMI
- Short latency time for high-priority messages
- Low power sleep mode with programmable wakeup on bus activity

1.2.11 Queued Serial Multi-Channel Module (QSMCM)

- Queued serial peripheral interface (QSPI)
 - Provides full-duplex communication port for peripheral expansion or interprocessor communication
 - Up to 32 preprogrammed transfers, reducing overhead
 - 160-byte queue buffer
 - Programmable transfer length: from 8 to 16 bits, inclusive
 - Synchronous interface with baud rate of up to system clock divided by 4
 - Four programmable peripheral-select pins support up to 16 devices
 - Wrap-around mode allows continuous sampling for efficient interfacing to serial peripherals (e.g., – serial A/D converters, I/O latches, etc.)
- Two serial communications interfaces (SCI). Each SCI offers these features:
 - UART mode provides NRZ format and half-or full-duplex interface
 - 16 register receive buffer and 16 register transmit buffer (SCI1 only)
 - Advanced error detection and optional parity generation and detection
 - Word length programmable as 8 or 9 bits
 - Separate transmitter and receiver enable bits and double buffering of data
 - Wakeup functions allow the CPU to run uninterrupted until either a true idle line is detected or a new address byte is received
 - External source clock for baud generation
 - Multiplexing of transmit data pins with discrete outputs and receive data pins with discrete inputs, allowing realization of a low-speed serial protocol

2 MPC555 Address Map

The internal memory map is shown in Figure 2.

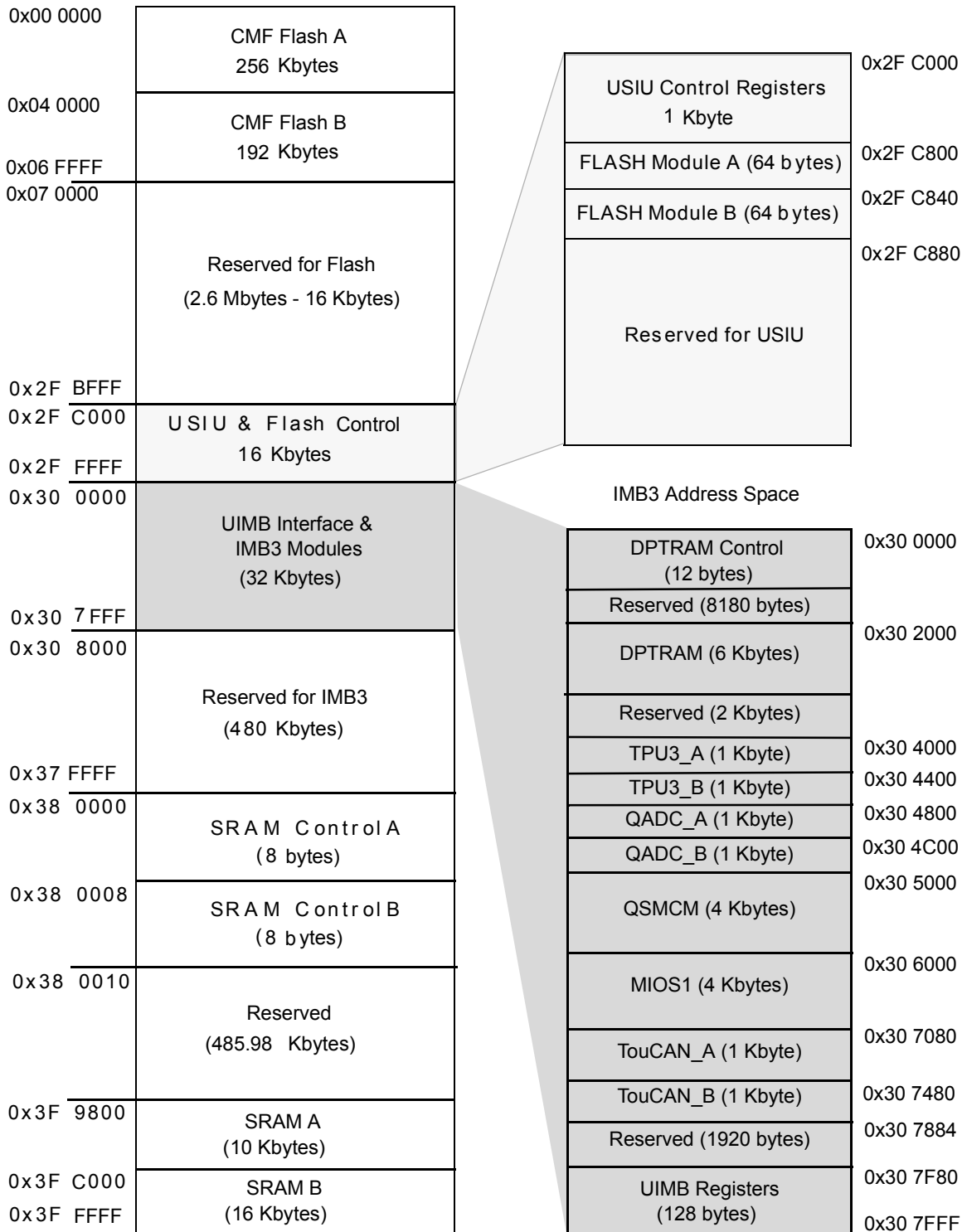

Figure 2. MPC555 Internal Memory Map

4 Supporting Documentation List

This list contains references to currently available and planned documentation.

- *MPC555 User's Manual* (MPC555UM/AD)
- *RCPURM Reference Manual* (RCPURM/AD)
- *Board Strategies for Ensuring Optimum Frequency Synthesizer Performance* (AN1282/D)
- *Using the MIOS on the MPC555 Evaluation Board* (AN1778/D)
- *Exception Table Relocation and Multi-Processor Address Mapping in the Embedded MPC5XX Family* (AN1821/D)
- *Non-Volatile Memory Technology Overview* (AN1837/D)
- *Designing Expansion Boards for the Freescale EVB555/ETAS ES200* (AN2001/D)
- *MPC555 Interrupts* (AN2109/D)
- *EMC Guidelines for MPC500-Based Automotive Powertrain Systems* (AN2127/D)
- Nexus Standard Specification (non-Freescale document)
- Nexus Web Site: <http://www.nexus5001.org/>
- IEEE 1149.1 Specification (non-Freescale document)

5 Revision History

Table 2. Revision History

Revision Number	Substantive Changes	Date of Release
2	Existing Document.	September 2001
2.1	Added temperature range for suffix A device.	11 December 2002
3	Updated template and formats.	11 February 2003

THIS PAGE INTENTIONALLY LEFT BLANK

THIS PAGE INTENTIONALLY LEFT BLANK

THIS PAGE INTENTIONALLY LEFT BLANK

MPC555PB/D

**For More Information On This Product,
Go to: www.freescale.com**