

Analog Peripherals

10-Bit ADC

- ± 1 LSB INL; guaranteed monotonic
- Programmable throughput up to 100 ksp/s
- 13 external inputs; programmable as single-ended or differential
- Programmable amplifier gain: 16, 8, 4, 2, 1, 0.5
- Data-dependent windowed interrupt generator
- Built-in temperature sensor (± 3 °C)

High-Voltage Differential Amplifier

- 60 V common mode input range
- Offset adjust from -60 to +60 V
- 16 gain settings from 0.05 to 16

8-Bit DAC

- Programmable throughput up to 500 ksp/s
- 8 external inputs; programmable as single-ended or differential
- Programmable amplifier gain: 4, 2, 1, 0.5

Two 12-Bit DACs

Three Comparators

Internal Voltage Reference

Precision V_{DD} Monitor/Brown-out Detector

On-Chip JTAG Debug & Boundary Scan

- On-chip debug circuitry facilitates full speed, non-intrusive in-system debug (no emulator required)
- Provides breakpoints, single stepping, watchpoints, stack monitor, program trace memory
- Inspect/modify memory and registers
- Superior performance to emulation systems using ICE-chips, target pods, and sockets
- IEEE1149.1 compliant boundary scan

High-Speed 8051 μ C Core

- Pipelined instruction architecture; executes 70% of instructions in 1 or 2 system clocks
- Up to 25 MIPS throughput with 25 MHz system clock
- Expanded interrupt handler

Memory

- 4352 bytes data RAM
- 64 kB Flash; in-system programmable in 512-byte sectors (512 bytes are reserved)
- External parallel data memory interface

CAN Bus 2.0B

- 32 message objects
- "Mailbox" implementation only interrupts CPU when needed

Digital Peripherals

- 32 port I/O; all are 5 V tolerant
- Hardware SMBus™ (I2C™ compatible), SPI™, and two UART serial ports available concurrently
- Programmable 16-bit counter array with 6 capture/compare modules
- 5 general-purpose 16-bit counter/timers
- Dedicated watchdog timer; bidirectional reset
- Real-time clock mode using timer 3 or PCA

Clock Sources

- Internal programmable 2% oscillator: up to 25 MHz
- External oscillator: Crystal, RC, C, or Clock

Supply Voltage: 2.7 to 3.6 V

- Typical operating current: 10 mA at 25 MHz
- Multiple power saving sleep and shutdown mode

64-Pin TQFP

- Temperature Range: -40 to +85 °C

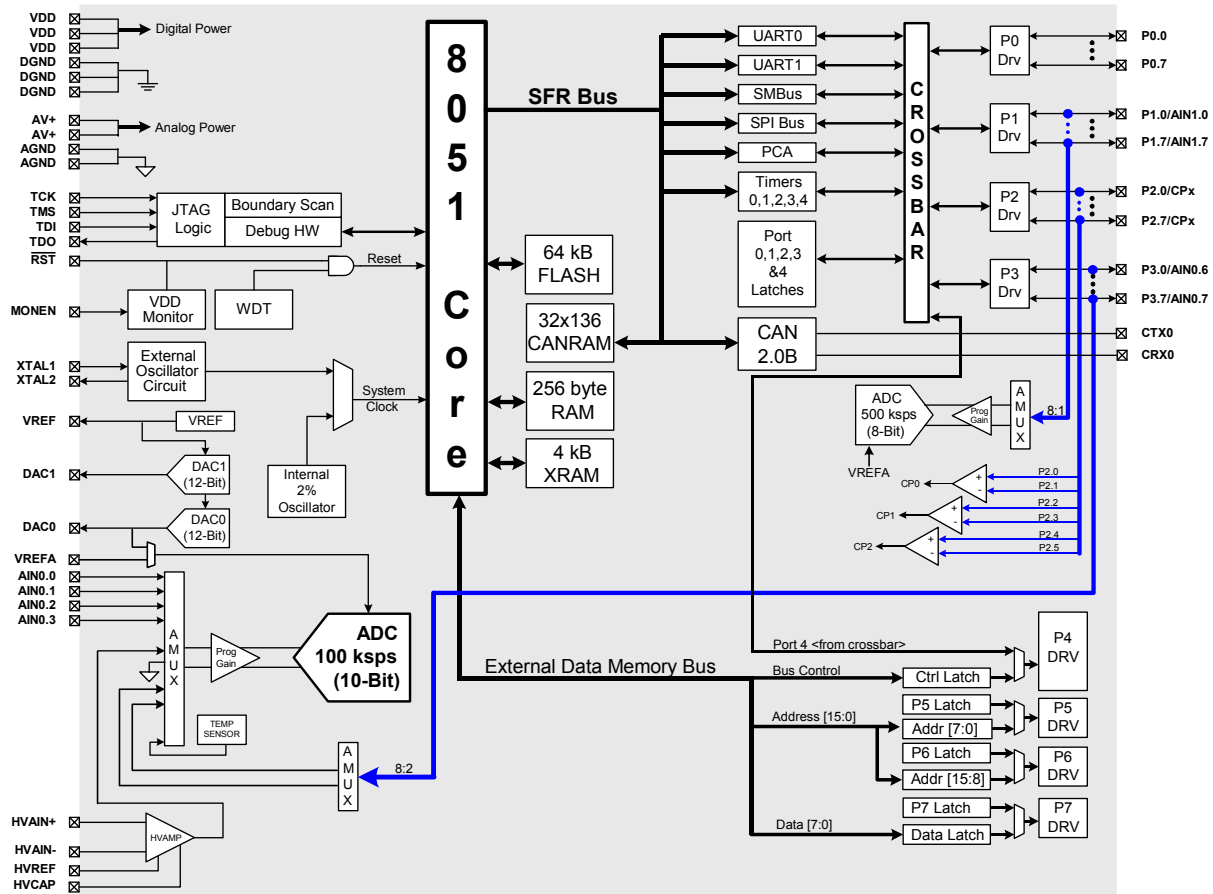

Selected Electrical Specifications

($T_A = -40$ to $+85$ °C, $V_{DD} = 2.7$ V unless otherwise specified)

PARAMETER	CONDITIONS	MIN	TYP	MAX	UNITS
GLOBAL CHARACTERISTICS					
Supply Voltage		2.7		3.6	V
Supply Current (CPU active)	Clock = 25 MHz		10		mA
	Clock = 1 MHz		0.5		mA
	Clock = 32 kHz; V_{DD} Monitor Enabled		20		μ A
Supply Current (shutdown)	Oscillator not running; V_{DD} Monitor Disabled		0.1		μ A
Clock Frequency Range		DC		25	MHz
A/D CONVERTER					
Resolution			10		bits
Integral Nonlinearity				± 1	LSB
Differential Nonlinearity	Guaranteed Monotonic			± 1	LSB
Signal-to-Noise Plus Distortion		59			dB
Throughput Rate				100	ksps
Input Voltage Range		0		V_{REF}	V
D/A CONVERTERS					
Resolution			12		LSB
Differential Nonlinearity				± 1	LSB
Output Settling Time			10		μ s
COMPARATORS					
Supply Current	(each Comparator)		1.5		μ A
Response Time	$ CP+ - CP- = 100$ mV		4		μ s

Package Information

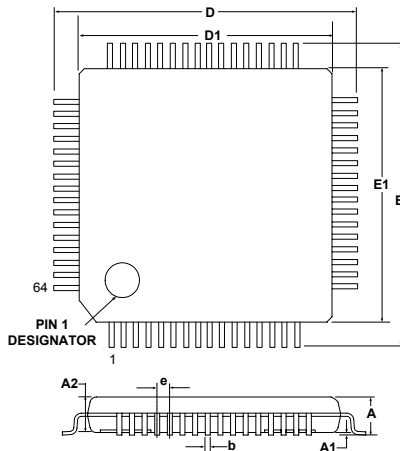

	MIN (mm)	NOM (mm)	MAX (mm)
A	-	-	1.20
A1	0.05	-	0.15
A2	0.95	-	1.05
b	0.17	0.22	0.27
D	-	12.00	-
D1	-	10.00	-
e	-	0.50	-
E	-	12.00	-
E1	-	10.00	-

C8051F040DK Development Kit

