

Analog Peripherals

12-bit ADC

- ± 1 LSB INL; no missing codes
- Programmable Throughput up to 200 ksp
- Up to 24 External Inputs; programmable as single-ended or differential
- Data Dependent Windowed Interrupt Generator
- Built-in Temperature Sensor (± 3 °C)
- Internal Voltage Reference—1.5 V, 2.2 V (programmable)

Two 12-Bit Current Mode DACs

Two Comparators

- Programmable hysteresis values and response time
- Configurable to generate interrupts or reset

POR/Brown-out Detector

On-Chip Debug

- On-chip debug circuitry facilitates full speed, non-intrusive in-system debug (no emulator required)
- Provides breakpoints, single stepping, watchpoints
- Inspect/modify memory, registers, and stack
- Superior performance to emulation systems using ICE-chips, target pods, and sockets

Supply Voltage: 2.0–5.25 V

- Built-in LDO regulator: 2.1 V or 2.5 V

smaRTClock™

- Battery switchover circuit
- Back-up power supply
- Oscillator failure detect
- Operates down to 1 V

High-Speed 8051 CPU

- Pipelined instruction architecture; executes 70% of instructions in 1 or 2 system clocks
- Up to 50 MIPS throughput with 50 MHz system clock
- Expanded interrupt handler

Memory

- 2304 bytes data RAM
- 16 kB, 32 kB Flash; in-system programmable in 512-Byte Sectors; Full Read/Write/Erase Functionality at 2.25 V_{DD}
- 64 bytes battery-backed RAM

Digital Peripherals

- 24 port I/O; up to 5.25 V tolerance
- Hardware SMBus™ (I2C™ compatible), SPI™, and UART serial ports available concurrently
- 16-bit programmable counter array with six capture/compare modules, WDT
- 4 general-purpose 16-bit counter/timers

Clock Sources

- Internal Oscillators: 24.5 MHz, 2% Accuracy Supports UART Operation; Clock Multiplier up to 50 MHz
- External Oscillator: Crystal, RC, C, or Clock (1 or 2 pin modes)
- External smaRTClock Oscillator: 32 kHz Crystal or self resonant oscillator
- Fast wake up from suspend mode in $< 1 \mu\text{s}$
- Can switch between clock sources on-the-fly

Available in 28-Pin QFN and 32-Pin LQFP

Temperature Range: -40 to $+85$ °C

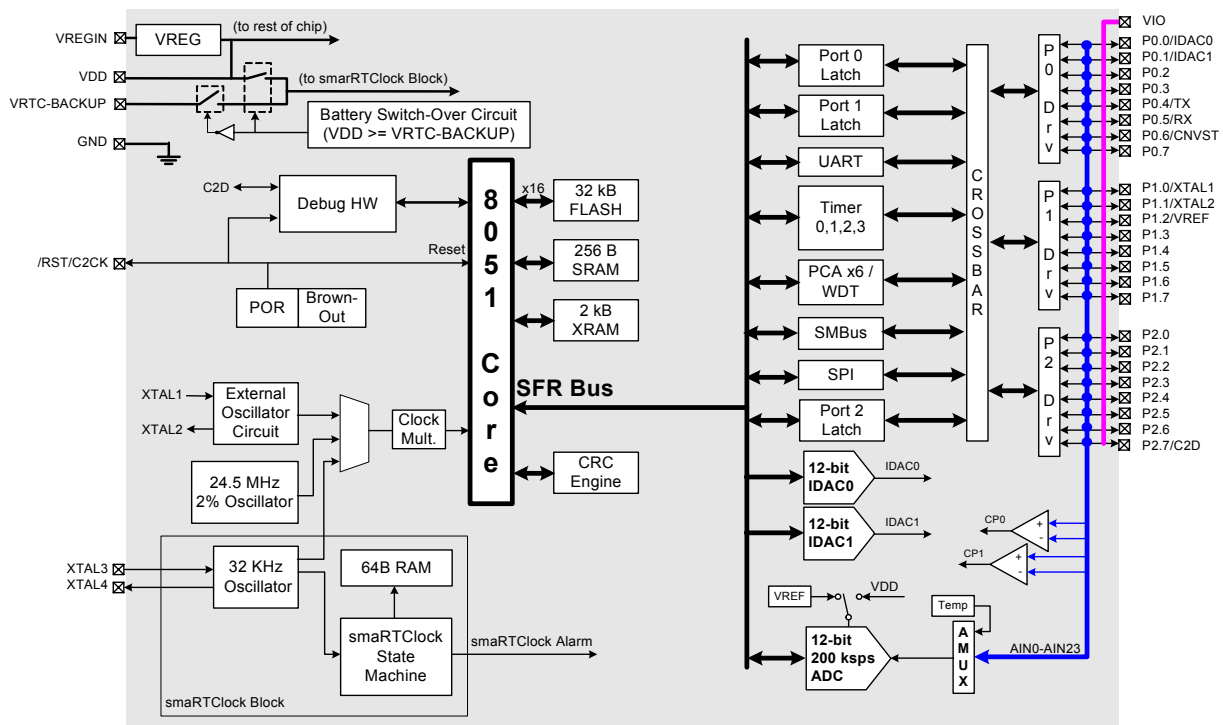

Selected Electrical Specifications

($T_A = -40$ to $+85$ C°, $V_{DD} = 2.0$ V unless otherwise specified)

Parameter	Conditions	Min	Typ	Max	Units
Global Characteristics					
Supply Input Voltage (V_{REGIN})	Output Current = 1 mA	2.15	—	5.25	V
Core Supply Voltage (V_{DD})		2.0	—	2.75	V
I/O Supply Voltage (V_{IO})	$V_{IO} \leq V_{REGIN}$	2.0	—	5.25	V
Supply Voltage (V_{RTC_BACKUP})		1.0	—	5.25	V
Supply Current with CPU active	$V_{DD} = 2.0$ V Clock = 32 kHz Clock = 1 MHz Clock = 50 MHz	—	13 0.3 9.5	—	μ A mA mA
Supply Current (shutdown)	Chip off; smaRTClock off Chip off; smaRTClock running $V_{BAT} = 1.0$ V Chip off; smaRTClock running $V_{DD} = 1.8$ V	—	<0.1 0.6 0.8	—	μ A μ A μ A
Clock Frequency Range		DC	—	50	MHz
Internal Oscillator					
Frequency		24	24.5	25	MHz
D/A Converter					
Resolution			12		bits
Differential Nonlinearity	Guaranteed Monotonic	—	—	± 1	LSB
Settling Time		—	5	—	μ s
A/D Converters					
Resolution			12		bits
Integral Nonlinearity		—	—	± 1	LSB
Differential Nonlinearity	Guaranteed Monotonic	—	—	± 1	LSB
Signal-to-Noise Plus Distortion		64	—	—	dB
Throughput Rate		—	—	200	ksps

Package Information

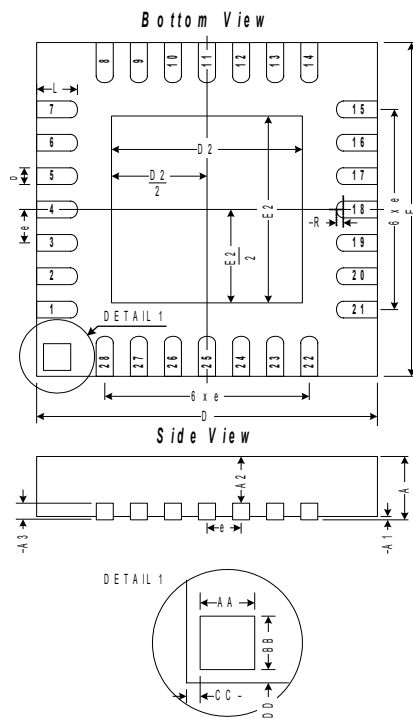

C8051F41xDK Development Kit

