

### Analog Peripherals

#### Comparator

- Programmable hysteresis and response time
- Configurable to generate interrupts or reset
- Low current (0.4  $\mu$ A)

#### POR/Brown-Out Detector

#### On-Chip Debug

- On-chip debug circuitry facilitates full speed, non-intrusive in-system debug (no emulator required)
- Provides breakpoints, single stepping, watchpoints
- Inspect/modify memory, registers, and stack
- Superior performance to emulation systems using ICE-chips, target pods, and sockets

#### Supply Voltage: 2.7 to 3.6 V

- Typical operating current: 5.8 mA at 25 MHz  
11  $\mu$ A at 32 kHz
- Typical stop mode current: <0.1  $\mu$ A

#### Temperature Range: -40 to +85 °C

### High-Speed 8051 $\mu$ C Core

- Pipelined Instruction architecture; executes 70% of instructions in 1 or 2 system clocks
- Up to 25 MIPS throughput with 25 MHz clock
- Expanded interrupt handler

### Memory

- 256 bytes data RAM
- 2 kB Flash; in-system programmable in 512 byte sectors (512 bytes are reserved)

### Digital Peripherals

- 8 port I/O; all are 5 V tolerant
- Enhanced Hardware SMBus™ (I2C™ compatible) and UART serial ports
- Programmable 16-bit counter/timer array with three capture/compare modules, WDT
- 3 general-purpose 16-bit counter/timers
- Dedicated watchdog timer; bidirectional reset
- Real-time clock mode using PCA or timer and external clock source

### Clock Sources

- Internal oscillator: 20 MHz nominal
- External oscillator: Crystal, RC, C, or Clock (1 or 2 pin modes)
- Can switch between clock sources on-the-fly

### Package

- 11-pin QFN
- 14-pin SOIC

### Ordering Part Numbers

- Lead-free package: C8051F305-GM (QFN)
- Lead-free package: C8051F305-GS (SOIC)

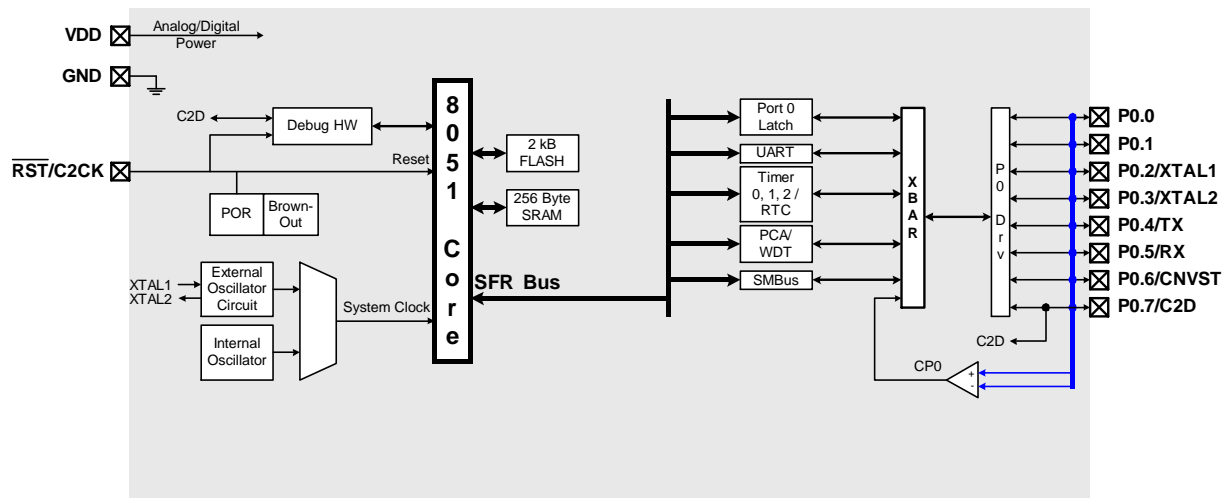

## Selected Electrical Specifications

( $T_A = -40$  to  $+85$  °C,  $V_{DD} = 2.7$  V unless otherwise specified)

PARAMETER	CONDITIONS	MIN	TYP	MAX	UNITS
<b>GLOBAL CHARACTERISTICS</b>					
Supply Voltage		2.7		3.6	V
Supply Current with CPU active	Clock = 25 MHz		5.8		mA
	Clock = 1 MHz		0.34		mA
	Clock = 32 kHz; $V_{DD}$ Monitor Disabled		11		$\mu$ A
Supply Current (shutdown)	Oscillator off; $V_{DD}$ Monitor Enabled		10		$\mu$ A
	Oscillator off; $V_{DD}$ Monitor Disabled		<0.1		$\mu$ A
Clock Frequency Range		DC		25	MHz
<b>INTERNAL OSCILLATOR</b>					
Frequency		15.0	20.0	25.0	MHz
<b>COMPARATOR</b>					
Response Time Mode0	(CP+) – (CP-) = 100 mV		0.1		$\mu$ s
Current Consumption Mode0			7.6		$\mu$ A
Response Time Mode1	(CP+) – (CP-) = 100 mV		0.18		$\mu$ s
Current Consumption Mode1			3.2		$\mu$ A
Response Time Mode2	(CP+) – (CP-) = 100 mV		0.32		$\mu$ s
Current Consumption Mode2			1.3		$\mu$ A
Response Time Mode3	(CP+) – (CP-) = 100 mV		1		$\mu$ s
Current Consumption Mode3			0.4		$\mu$ A

## Package Information

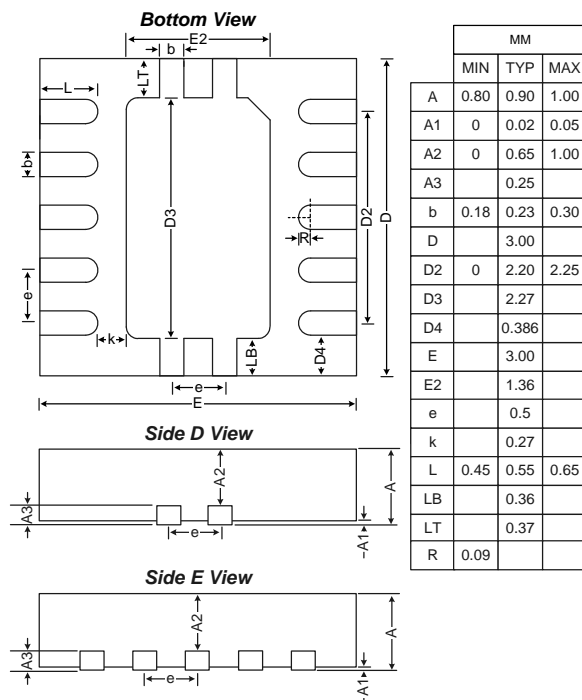

## C8051F300DK Development Kit

