



120 MHz, 32-bit
Microcontrollers with
Cortex-M3™ core,
LPC1700 series

Cortex-M3 based microcontrollers with Ethernet, USB, CAN and 12-bit ADC

The LPC1700 series of low power cost-effective Cortex-M3 microcontrollers feature best-in-class peripheral support such as Ethernet, USB 2.0 Host/OTG/Device, and CAN 2.0B. Operating at speeds up to 120 MHz, they have up to 512 KB of FLASH, up to 64 KB of SRAM, 12-bit A/D and 10-bit D/A converters as well as an internal RC oscillator.

Key Features

- ▶ ARM Cortex-M3 core
 - Up to 120 MHz operation
 - Nested Vectored Interrupt Controller for fast deterministic interrupts
 - Wakeup Interrupt Controller allows automatic wake from any priority interrupt
 - Memory Protection Unit
 - Four reduced power modes: Sleep, Deep-sleep, Power-down and Deep power-down
- ▶ Memories
 - Up to 512 KB Flash memory
 - Up to 64 KB SRAM
- ▶ Serial Peripherals
 - 10/100 Ethernet MAC
 - USB 2.0 full-speed device/Host/ OTG controller with on-chip PHY
 - Four UARTs with fractional baud rate generation, RS-485. modem control I/O, and IrDA
 - Two CAN 2.0B controllers
 - Three SSP/SPI controllers
 - Three I²C-bus interfaces with one supporting fast mode plus (1 Mbit/s data rates)
 - I²S interface for digital audio
- ▶ Analog Peripherals
 - 12-bit Analog-to-Digital Converter with eight channels
 - 10-bit Digital-to-Analog Converter
- ▶ Other Peripherals
 - Real-Time Clock operating at < 1 uA
 - Eight channel General Purpose DMA controller
 - Up to 70 General Purpose I/O
 - Motor control PWM and Quadrature Encoder Interface to support three-phase motors
 - Four 32-bit general purpose timers/counters
 - 4 MHz internal RC oscillator trimmed to 1 % accuracy

The NXP LPC1700 series uses a low power, cost effective Cortex-M3 core that operates at up to 120 MHz. Each device has up to 512 KB of Flash and up to 64 KB of SRAM. The LPC1700 series features a multi-layer AHB bus that allows high-bandwidth peripherals such as Ethernet and USB to run simultaneously, without impacting performance.



The LPC176x devices are available in an LQFP100 package while the LPC175x MCUs are offered in an LQFP80 package. The LPC1700 series is pin compatible with the popular NXP LPC2300 series of ARM7 microcontrollers, allowing designers to compare the M3 and ARM7 cores in the same

socket and simply choose the microcontroller that is best for their application. With its wide array of peripherals and high performance, the LPC1700 is ideal for e-Metering, lighting, industrial networking, alarm systems, white goods and motor control applications.

Selector Guide

Part Number	Max Clock (MHz)	Flash (KB)	SRAM (KB)	Ethernet	USB	CAN	I ² S	ADC	DAC	I ² C	I/O Pins	Package
LPC1769	120	512	64	Y	Device/Host/OTG	2	Y	8	Y	3	70	LQFP100
LPC1768	100	512	64	Y	Device/Host/OTG	2	Y	8	Y	3	70	LQFP100
LPC1767	100	512	64	Y	None	0	Y	8	Y	3	70	LQFP100
LPC1766	100	256	64	Y	Device/Host/OTG	2	Y	8	Y	3	70	LQFP100
LPC1765	100	256	64	N	Device/Host/OTG	2	Y	8	Y	3	70	LQFP100
LPC1764	100	128	32	Y	Device	2	N	8	N	3	70	LQFP100
LPC1759	120	512	64	N	Device/Host/OTG	2	Y	6	Y	2	52	LQFP80
LPC1758	100	512	64	Y	Device/Host/OTG	2	Y	6	Y	2	52	LQFP80
LPC1756	100	256	32	N	Device/Host/OTG	2	Y	6	Y	2	52	LQFP80
LPC1754	100	128	32	N	Device/Host/OTG	1	N	6	Y	2	52	LQFP80
LPC1752	100	64	16	N	Device	1	N	6	N	2	52	LQFP80
LPC1751	100	32	8	N	Device	1	N	6	N	2	52	LQFP80

Third-Party Development Tools

The following featured development tools will support the NXP LPC1700 series:

- ▶ Evaluation Boards
 - Embedded Artists
 - Hitex LPC17xx-Stick
 - mbed LPC1768 board
 - IAR KSDK-LPC17xx
 - Keil MCB17xx
- ▶ IDEs
 - Hitex HiTOP IDE
 - IAR Embedded Workbench for ARM (EWARM)
 - Keil µVision3
 - CodeRed Eclipse-based Red Suite
 - NXP LPCXpresso
- ▶ JTAG debuggers
 - All debuggers supporting Cortex-M3™

LPC1700 Block Diagram

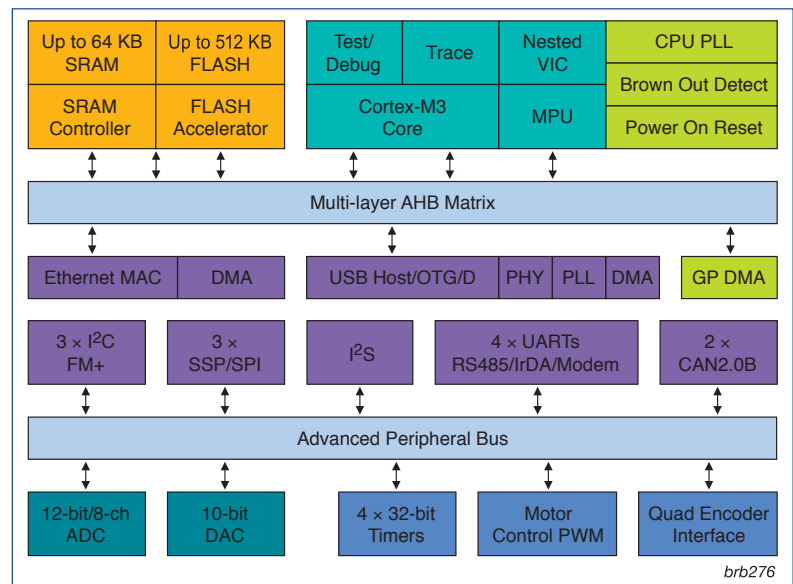

For more information on our development tools please visit www.nxp.com/microcontrollers