

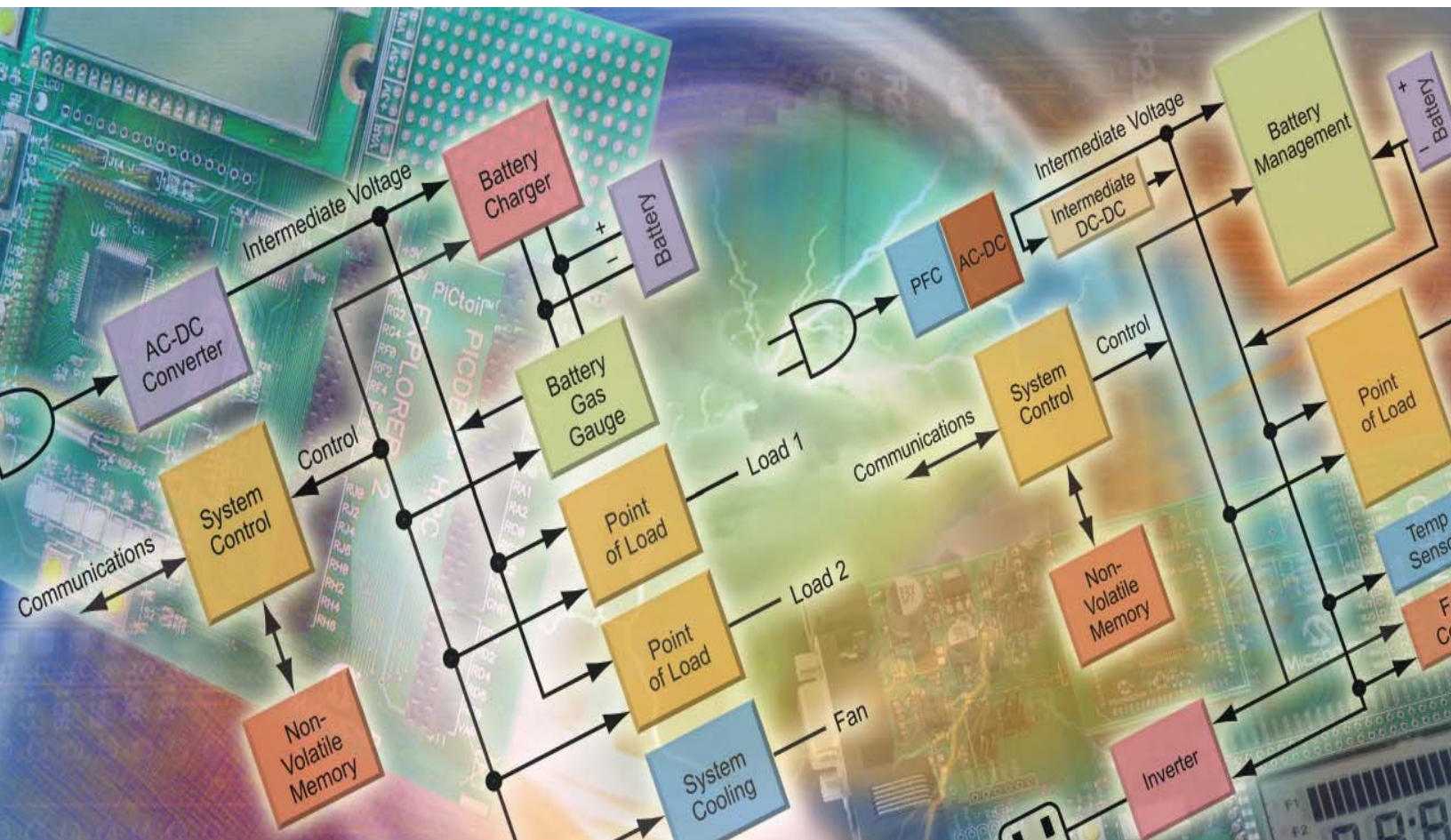

## Intelligent Power Supply Design Solutions



# Discover Microchip's Comprehensive Intelligent Power Supply Solutions

*Today, power supply designers must create power conversion products that offer greater efficiency, higher power density, higher reliability, advanced communications and advanced control features. And as always these products need to be developed and marketed quickly and at lower costs. Microchip offers a comprehensive set of Intelligent Power Supply solutions enabling designers to meet these challenges.*

## What is an Intelligent Power Supply?

Traditional power supply designs use analog ICs with fixed functionality to provide regulated power. The intelligent power supply integrates a microcontroller (MCU) or digital signal controller (DSC) for a fully programmable and flexible solution. Below are some examples of Intelligent Power Supply functions:

- Digital On/Off control for low standby power
- Power supply sequencing and hot-swap control
- Programmable soft-start profile
- Power supply history logging and fault management
- Output voltage margining
- Current fold back control
- Load sharing and balancing
- Regulation reference adjustment
- Compensation network control and adjustment
- Full digital control of power control loop
- Communications
- AC RMS voltage measurement
- Power factor correction

Example Intelligent Power Supply applications include the following:

- AC-to-DC Converters
- DC-to-DC Converters
- Uninterruptible Power Supply (UPS)
- Renewable Power/Pure Sine Wave Inverters
- Battery Chargers
- HID, LED and Fluorescent Light Ballasts

## Why Intelligent Power Conversion?

Using digital control to implement power conversion functions, developers can realize many benefits for their designs and businesses. These are enabled by the ability to perform the power conversion control via reprogrammable software and the performance and features of the MCU and DSC solutions from Microchip.

**Intelligent power conversion lowers the system component count.** Valuable board space can be made available for magnetics and power components. Power supply control, regulation, and protection functions can be incorporated into the same device. Auxiliary functions, such as fan control and data logging, are easily integrated.

**Intelligent power conversion allows configuration for different applications.** With intelligent power conversion, the power supply becomes a platform solution for many different applications. The power supply can easily be reprogrammed to support different output voltage levels, operating limits and control inputs. This reduces inventory overhead and the support required for multiple platforms.

**Intelligent power conversion increases system efficiency.** A power supply without intelligence must be optimized for one operating point. A change in the operating load usually means a drop in efficiency level. An intelligent power supply design can adapt to load changes using many methods. These include a change of the power supply switching frequency and changes in the analog control loop configuration. Intelligent power supplies can monitor internal temperatures and supply power to cooling fans only when needed. Intelligent power supplies with a digital control loop can change the control loop behavior dynamically to provide the optimal system response for the load conditions.

**Intelligent power conversion lowers standby power consumption.** Intelligence can be added to a power supply design that consumes only milliwatts or microwatts from the AC input. Electronic control inputs can be monitored while the bias supplies for the application are turned off.

## How Can Microchip Help?

Along with a local and global non-commissioned sales force, Microchip provides these products and resources for power conversion applications:

- 8-, 16- and 32-bit microcontrollers and 16-bit digital signal controllers
- MOSFET gate drivers
- Analog and interface products (temperature sensors, digital potentiometers and op amps)
- Serial EEPROM memory products
- Power conversion development tools, reference designs, algorithms and software
- Power conversion training and technical support

# Whole Product Solution

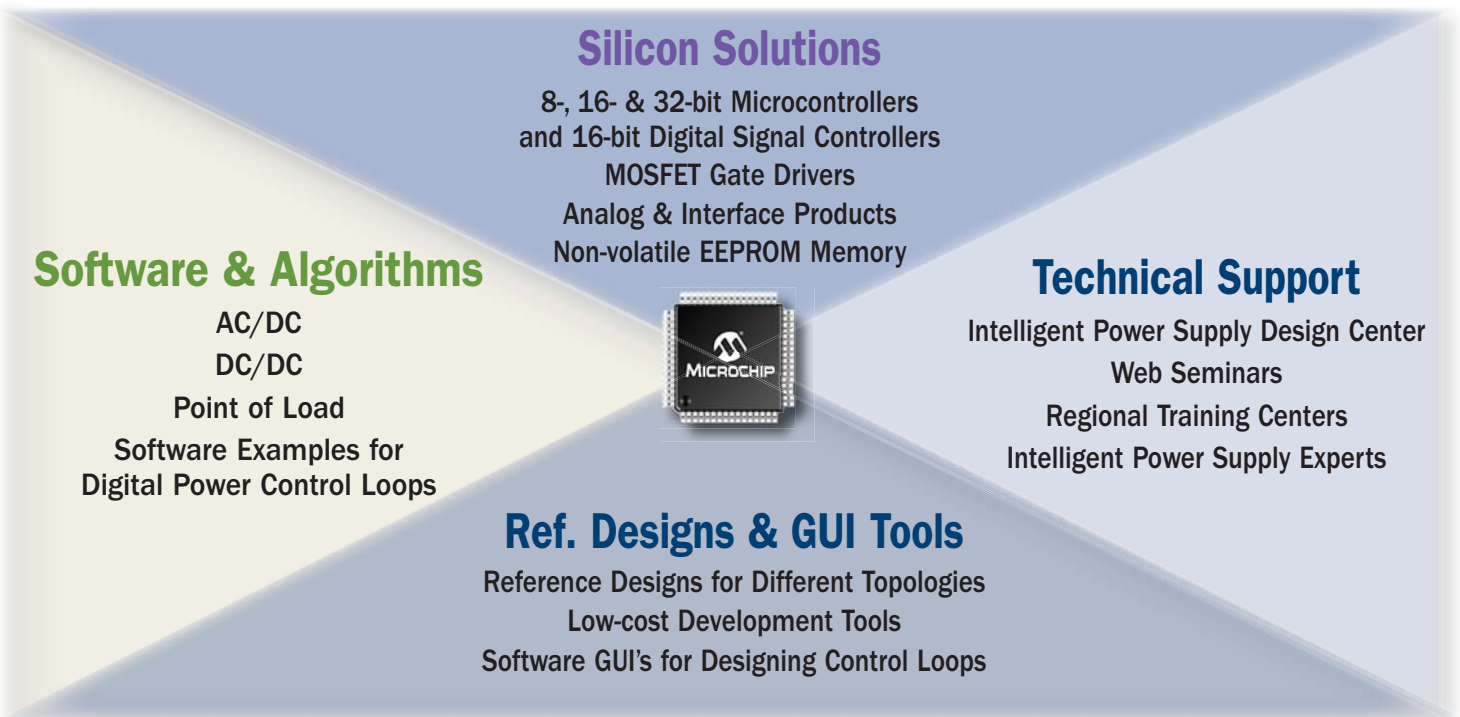

## Power Supply Design Integration Levels

Microchip delivers everything a power conversion design engineer needs: low-risk product development, lower total system cost, faster time to market, outstanding technical support and dependable delivery and quality.

An Intelligent Power Supply does not need to be complex or expensive. With MCUs and DSCs from 6 to 100 pins, Microchip has an appropriate device solution for every application. Many simple tasks can be implemented with a low-cost MCU that contains basic peripherals. For more demanding applications, many of our MCUs and DSCs have innovative on-chip peripherals designed specifically for power conversion. These peripherals include fast PWM modules with special operating modes and high-speed Analog-to-Digital Converters (ADCs) for fast acquisition of power supply information.

Description	Technical Functions	Recommended Devices
<b>Level 1: On/Off Control</b>	<ul style="list-style-type: none"> <li>– Low-power standby</li> <li>– Programmable soft start</li> <li>– Power up sequencing</li> <li>– Primary/secondary communication bridge</li> </ul>	PIC10F PIC12F
<b>Level 2: Proportional Control</b>	<ul style="list-style-type: none"> <li>– Output voltage margining</li> <li>– Load sharing and balancing</li> <li>– History logging</li> <li>– Primary/secondary communication bridge</li> </ul>	PIC12F PIC16F PIC18F PIC24F
<b>Level 3: Topology Control</b>	<ul style="list-style-type: none"> <li>– Optimize control loop for load changes</li> <li>– Enable common platform for multiple applications</li> <li>– Operational flexibility for different power levels</li> </ul>	PIC16HV785 MCP1631 High-Speed PWM Controller PIC18F
<b>Level 4: Full Digital Control</b>	<ul style="list-style-type: none"> <li>– Dynamic control loop adjustment</li> <li>– Predictive control loop algorithms</li> <li>– Operational flexibility for different power levels</li> </ul>	dsPIC30F dsPIC33F

# Power Supply Design Integration Levels

## Level 1 Integration: On/Off Control

At Level 1, electronic intelligence augments a standard analog design. The intelligence provides limited On/Off control functions such as start-up sequencing, automatic shutdown and watchdog fault detection functions. More sophisticated solutions can provide logging functions for later failure analysis, remote communication and customized thermal control algorithms. With Level 1 intelligence, a designer can ensure that the power supply has a deterministic response to system fault events. Solutions at this level benefit from Microchip's Baseline and Mid-Range MCUs and analog products.

Now it's easy to make your existing analog power supply intelligent without major hardware modifications and few software changes. Microchip's PIC10F and PIC12F 8-bit low pin count and small package microcontrollers with built-in peripherals, such as ADC, PWM and GPIOs, can make the existing analog power supplies intelligent by controlling the output sequencing and monitoring of input/output voltage, current and temperature.

## Simple Control and Monitoring

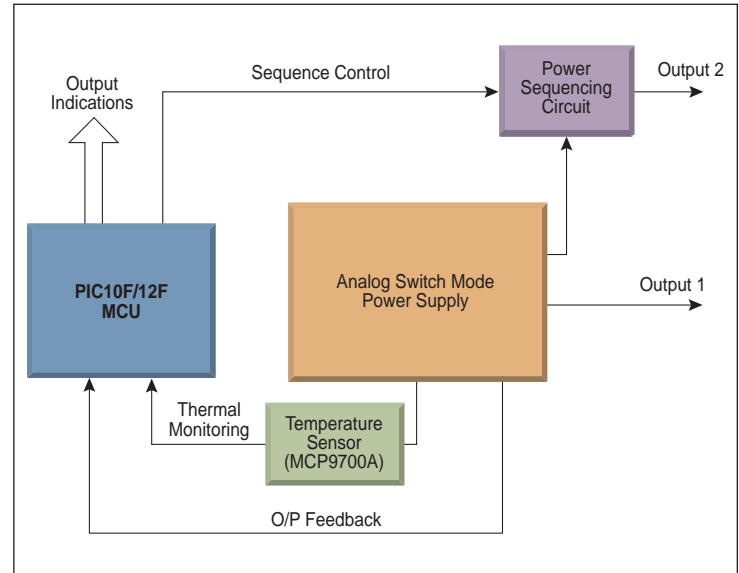

## Level 2 Integration: Proportional Control

This integration level adds additional digital control to the standard analog design. In addition to Level 1 control features, it is possible to control output voltage, voltage limits, current limits and thermal limits. At this level, most of the operating parameters of the analog power supply can be digitally controlled and monitored. Different

## Digital Monitoring to Analog Power Supply

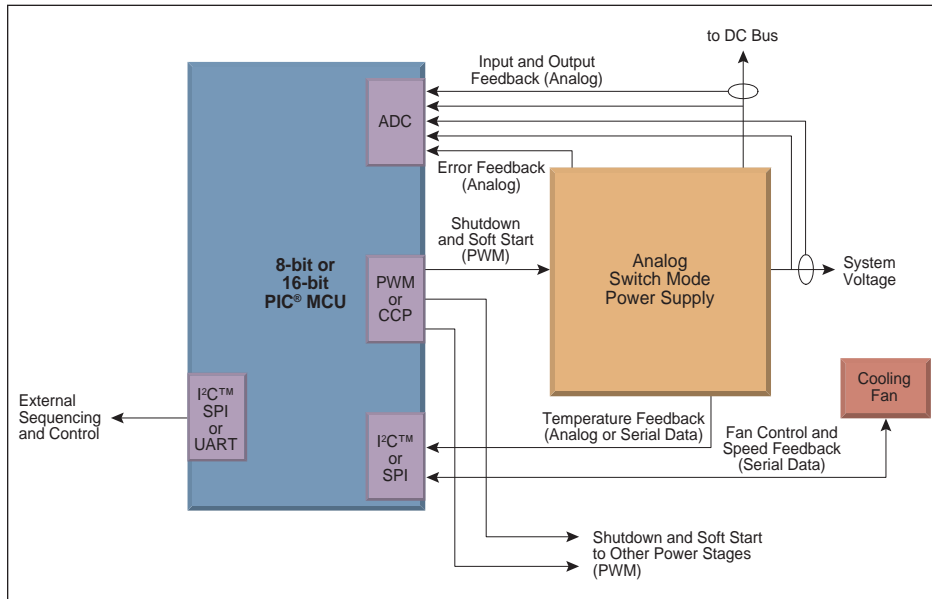

soft-start profiles and current limits can be programmed to suit the application. The output voltage can be fine-tuned to provide coordination between multiple power supplies in a system. Depending on the system I/O requirements, 8-bit solutions in the PIC12, PIC16 or PIC18 device families can provide the ideal solution. In larger systems, the 16-bit PIC24 device family can provide more communication peripherals.

A Level 2 control system has much greater integration with the power supply and allows greater power supply environment monitoring. An ADC is used to monitor the power supply inputs and outputs. On-chip comparators can also be employed to ensure fast response to system

events or faults. A PWM peripheral provides direct control of the analog PWM circuitry of the power unit. The PWM control can be used to gate the analog power supply under power-up conditions to provide soft-start. The MCU can monitor the power supply input current during the soft-start to ensure that components are not over-stressed. Serial communication peripherals allow coordination from a host device, control and monitoring of cooling fans, and monitoring of temperature sensors.

# Power Supply Design Integration Levels

## Level 3 Integration: Topology Control

This level permits the standard analog design to be reconfigured in addition to Level 1 and Level 2 features. Changing the analog loop configuration and swapping between two different analog control loop filters can be achieved. For example, a power supply can change from a PWM control loop to a hysteretic control loop at light

### PIC16HV785 Boost LED Driver Application

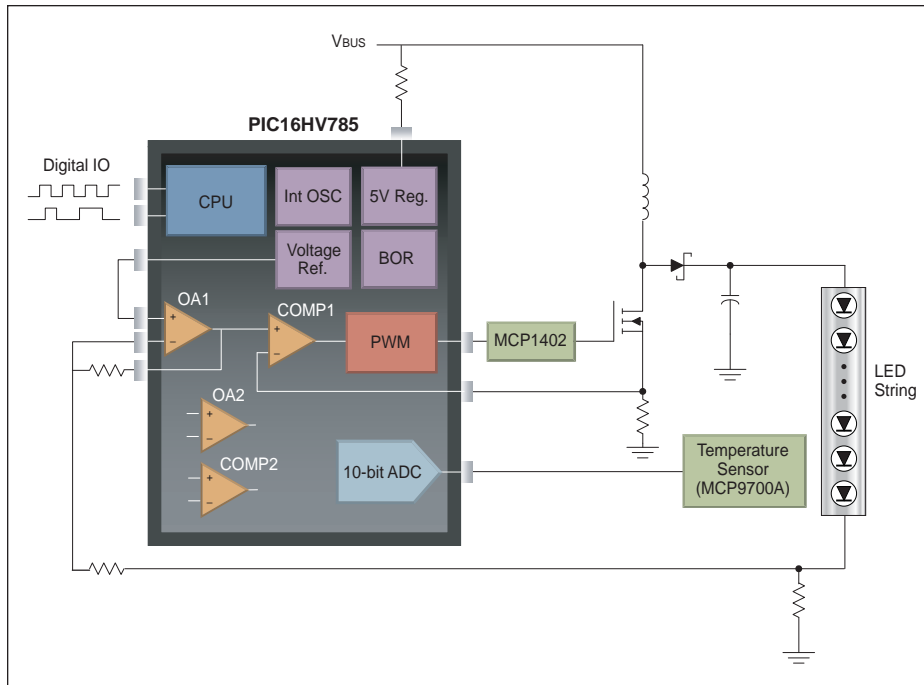

loads. This change would allow a continuous inductor current design to operate in discontinuous conduction mode, increasing system efficiency. Switching frequency adjustment can also be used to minimize losses. Microchip's entire range of MCUs and DSCs can assist in Level 3 control applications. In particular, mixed-signal solutions such as the PIC16F785 integrate an MCU with analog peripherals and are well-suited for topology control. In addition, the MCP1630 and MCP1631 PWM controllers are designed for MCU power controller applications.

The PIC16HV785 can be used in a Level 3 application due to the on-chip analog peripherals. The device has two analog PWM modules that can control power stages. Two error amplifiers and two high-speed comparators can be connected

to the PWM modules in many ways through digital configuration. All pins associated with the error amplifiers and comparators are available externally so any type of analog control loop can be created. Twelve ADC inputs are available to monitor power supply operating parameters.

### MCP1631HV Block Diagram

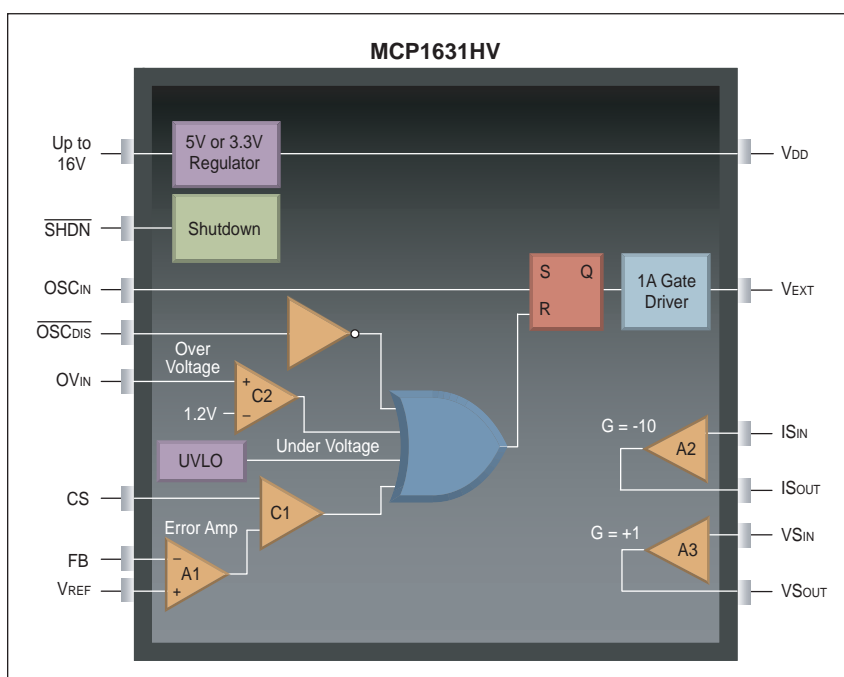

The MCP1631 high-speed PWM controller can be used as a building block for intelligent power supplies. The MCP1631 supplies the necessary analog peripherals, including the error amplifier, comparator and a high current output driver. The voltage reference and switching clock are supplied externally from an MCU. The MCU can set the switching frequency of the power stage, limit the maximum duty cycle and adjust the phase of the switching clock with respect to other power stages. The rich feature set of the MCP1631 device makes it a good fit for Level 2 and Level 3 intelligent power applications.

# Power Supply Design Integration Levels

## Moving to a Higher Level: Level 4 Full Digital Control

Full digital control replaces the standard analog control loop design and also provides the power management functions of Levels 1-3 integration. The power supply regulation function is directly controlled by the digital circuits on the processor and the software running on the processor. The full digital solution allows the designer to employ techniques that are not possible with the analog solution, including proprietary digital compensation algorithms and non-linear control techniques. The full digital solution enables a customized response to power input change or load change events, which can lower system cost and increase system efficiency.

Microchip's 16-bit dsPIC® DSCs enable the Level 4 solution. Feedback from the power supply is obtained using high-speed ADCs. The power supply is controlled using specialized high-speed PWM peripherals. The PWM module can directly drive all popular power supply topologies and the CPU core allows digital compensation algorithms to be executed quickly.

## PFC with Advanced Digital Control

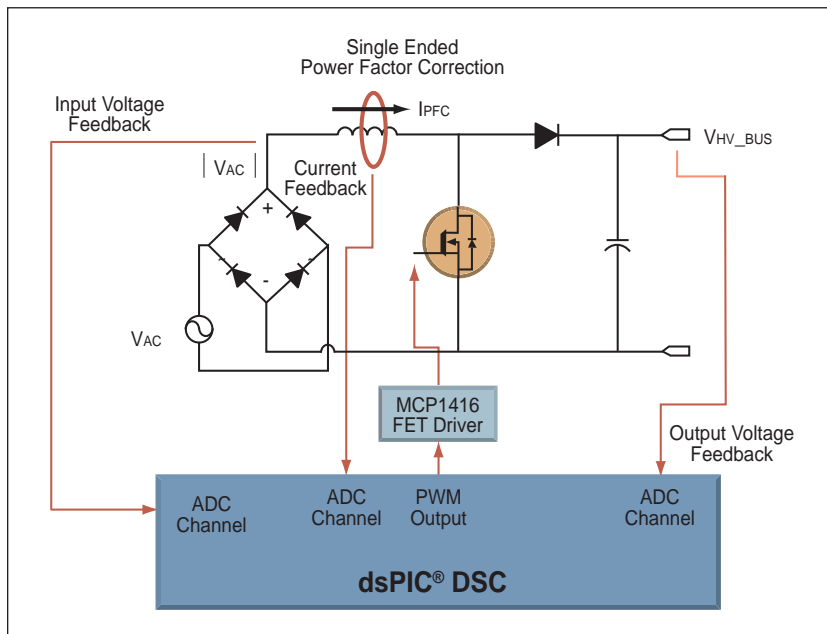

Power Factor Correction (PFC) is essential in higher wattage power supplies to reduce harmonic content, system losses and radiated emissions. In this example the dsPIC DSC simplifies the implementation of a Boost-PFC algorithm using Average Current Mode Control. The PWM command is calculated digitally by computing the product of rectified input voltage, the output of the voltage error compensator and the output of the voltage Feed-Forward Compensator. The digital PFC function uses few DSC resources, leaving plenty of additional capability to perform the rest of the primary side control.

# Power Supply Design Integration Levels

The features of the dsPIC DSC devices enable full digital control of applications such as this AC-DC converter. The high-speed PWM module with multiple advanced operating modes helps implement various advanced conversion stages such as PFC, phase shift zero voltage transition converter with full-bridge conversion and synchronous rectification and multi-phase buck converters. Our high-speed ADC conversions can be triggered at precise times in relation to the PWM signal supporting fast control loops. The high-performance CPU enables implementing advanced PID digital control loops and compensators in software.

## AC-DC Conversion with Complete Digital Control

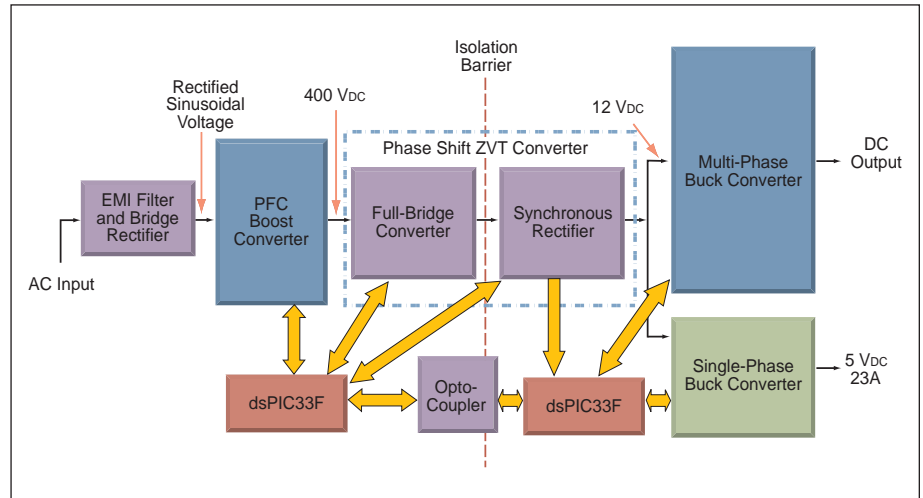

## Phase-Shifted Full-Bridge DC-DC Converter

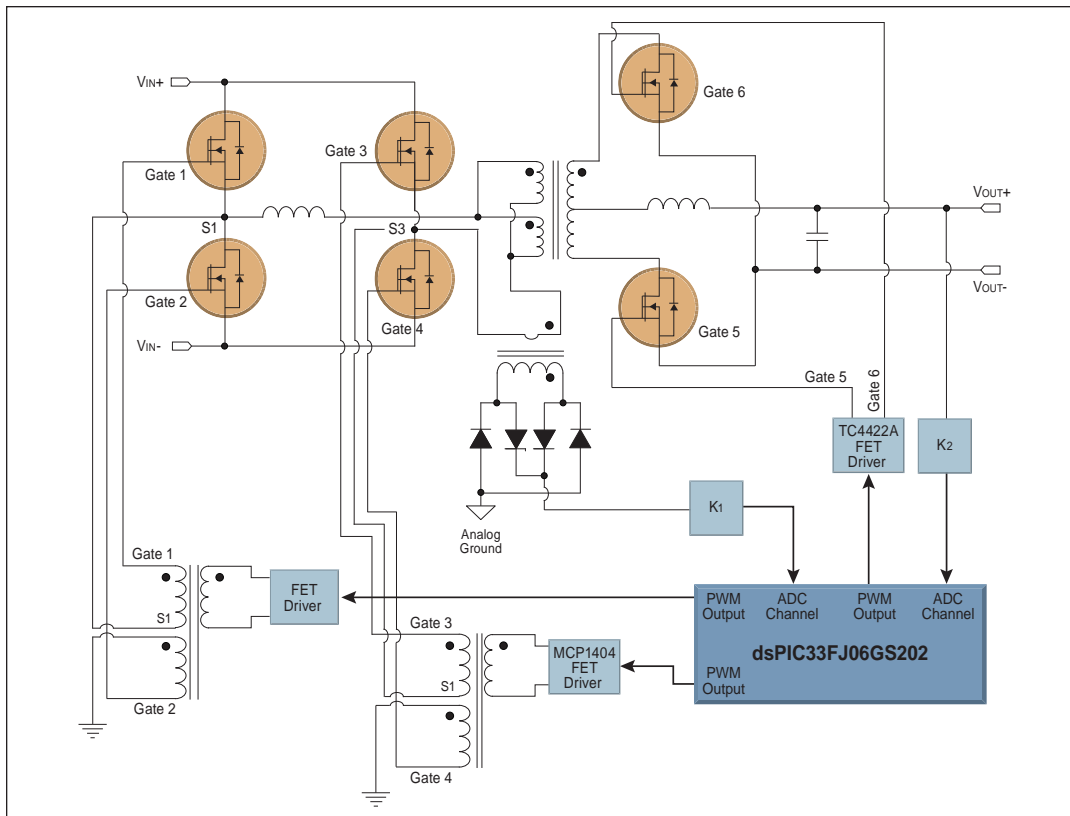

The dsPIC33FJXXGS DSC family in power efficient and highly integrated DC-DC converters dynamically controls different power stages. High-speed ADC, PWM and comparators work together without using much CPU bandwidth. Faster digital control loops and compensators can be executed using a high-performance DSP engine. Advanced features such as dynamic load response, protections, sequencing, remote control and communications can also be implemented.

# Which MCU or DSC Should You Choose?

## Microchip Provides Many 8-bit Devices That Can Be Used In Power Supply Applications

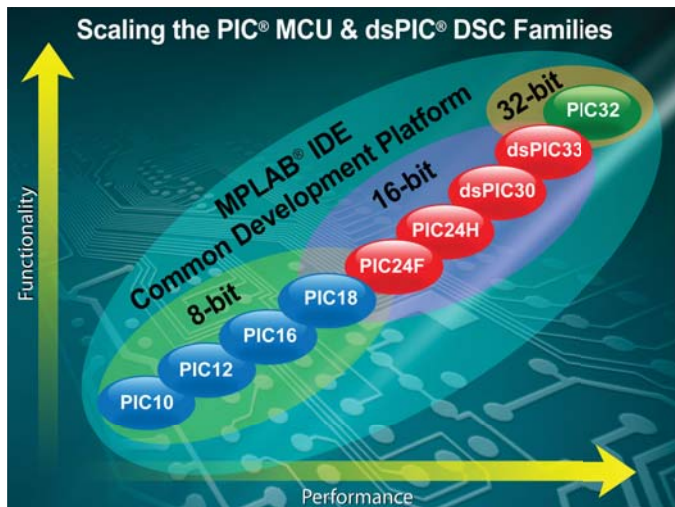

Microchip makes many families of 8-, 16- and 32-bit MCU and 16-bit DSC solutions that can be used in various intelligent power applications, enabling a designer to support the level of digital integration and performance required for the application.

### PIC10F Microcontroller Product Family

The 6-pin PIC10F family allows digital features to be integrated into any power supply design with a cost structure that makes them nearly disposable. The on-chip ADC, comparator and timer peripherals can be used to augment analog power supply designs, providing On/Off control, soft-start, power sequencing or monitoring features to the application. Only simple programming skills are required to create the software. The PIC10F features include:

- 2x3 DFN or 6-pin SOT-23 package
- Internal oscillator
- Comparator
- Internal 8-bit ADC

### PIC12F and PIC16F Microcontroller Product Families

The PIC12F devices are available in small 8-pin packages, while PIC16F variants are offered in 14-pin through 64-pin packages. These device families are suitable for proportion control (Level 2 integration). Some variants in the PIC16F family have one or more enhanced capture compare PWM (ECCP) modules that can be used to generate references for analog control loops. Built-in ADCs can be used to monitor input/output voltage and current and temperature. Comparators can be employed to monitor fault inputs. Communication peripherals like UART, SPI and I<sup>2</sup>C™ can be used for remote monitoring and control. Key features of these microcontroller families are:

- Up to 5 MIPS of operation
- One or more ECCP modules
- Comparator with input multiplexer
- 8-bit or 10-bit ADC
- Internal RC Oscillator
- Internal 5V Shunt Regulator
- Communication interfaces: USART, SPI, I<sup>2</sup>C

### PIC18F Microcontroller Product Family

The PIC18F product family also has an 8-bit CPU and offers extended performance over the PIC16F device family. The PIC18F device family can operate at speeds up to 16 MIPS and has a hardware multiplier for faster calculation of control algorithms. There are variants in the PIC18F family with specialized PWM, ECCP modules. The PIC18F family devices are good matches for configuration or topology control (Level 3). An internal 10- or 12-bit ADC with fast sampling rate can be used to monitor feedback parameters and can monitor in/out voltage and currents. Communication peripherals like UART, SPI and I<sup>2</sup>C can be used to implement remote monitoring and controlling features.

- Up to 16 MIPS execution speed with H/W multiplier
- Up to 10 CCP/ECCP modules
- 10- or 12-bit ADC (with up to 200 ksp/s sample rate on PIC18F)
- Up to 3 internal comparators
- Internal 5V Shunt Regulator
- Communication interfaces: EUSART, SPI, I<sup>2</sup>C, CAN, Ethernet and USB



# 16-bit Solutions for Intelligent Power Supply Designs

## PIC24F Microcontroller Family

The PIC24F product family is Microchip's entry level 16-bit microcontroller, providing a path from the PIC18F to extended performance, program memory and RAM. The PIC24F can operate at speeds up to 16 MIPS and has a hardware multiplier for fast calculation of control algorithms. The PIC24F family offers devices with multiple UART, SPI and I<sup>2</sup>C serial communication channels for remote monitoring or control. The PIC24F devices also include multiple Input Capture and Output Compare/PWM, comparators and a high-speed 10-bit ADC.

One key feature of the low pin count PIC24F is Peripheral Pin Select (PPS). PPS allows the designer to minimize the cost of the design by selecting the lowest pin count device needed to meet the needs of the system.

- Up to 16 MIPS execution speed with H/W multiplier
- 4 UART, 3 SPI and 3 I<sup>2</sup>C
- 9 Input Capture and 9 Output Compare/PWM
- 10-bit ADC with up to 500 ksp/s sample rate
- 3 internal comparators
- Integrated USB OTG and embedded host

## 16-bit Product Family with Advanced Peripherals for Digital Power Control

Implementing advanced software digital control loops for power applications requires a high-performance DSP engine along with specialized peripherals. The high-performance CPU and rich peripherals of the dsPIC DSC devices enable solutions that do not require much in the way of external support chips. In addition to the space and cost-saving benefits found in the dsPIC DSC solutions, special features enable advanced power conversion.

The DSP engine can perform single-cycle MAC with data saturation, zero overhead looping and barrel shifting required to support fast control loop execution. These devices include peripherals specifically designed for power conversion. Peripherals such as a high-speed PWM, ADC and analog comparators can be tied together using an internal configurable control fabric that enables them to interact directly with one another, resulting in stunning performance gains in digital power applications.

### dsPIC® SMPS and Digital Power Conversion and dsPIC® Motor Control and Power Conversion Family

- Large family of code- and pin-compatible Flash devices
- Up to 40 MIPS 16-bit CPU with compiler-efficient architecture
- Built-in DSP engine enables high-speed and precision digital power control loops
- Single supply voltage rails eliminate extra voltage regulator circuits
- Precision high-speed internal oscillator eliminates external crystal
- Comprehensive system integration features

### Advanced On-chip Intelligent Power Peripherals

Microchip's 16-bit dsPIC DSCs provide on-chip peripherals specifically designed for high-performance, intelligent power supplies:

- Power Supply PWM Module (High-speed PWM Module)
  - Up to 1 nanosecond resolution
  - Highly configurable supporting all common topologies
  - High resolution at high PWM frequencies
  - Trigger events from PWM to ADC
- High-speed Analog-to-Digital Converter (ADC)
  - 10-bit/12-bit resolution
  - Up to 4 Msps
  - Sophisticated triggering capabilities
- High-speed analog comparator
  - Up to four analog comparators
  - Up to four integrated 10-bit DAC references
  - Outputs can directly trigger PWM and ADC events
- Additional channels of 16-bit timers, input capture, output compare and standard PWM
- Communication interfaces include UART, SPI, I<sup>2</sup>C, CAN

# Product Tables

## dsPIC33F SMPS and Digital Power Conversion Family

Device	Pins	Flash KB	RAM Bytes	Timer 16-bit	DMA # Ch	Input Capture	Output Compare/Standard PWM	PS PWM	QEI	ADC 10-bit 2/4 Msps	10-bit DAC O/P	Analog Comparators	UART	SPI	IC™	ECAN	JTAG	Package Code
dsPIC33FJ06GS101	18	6	256	2	-	-	1	4	-	6 ch, 3 S&H	-	-	1	1	1	-	N	SO
dsPIC33FJ06GS102	28	6	256	2	-	-	1	4	-	6 ch, 3 S&H	-	-	1	1	1	-	Y	SO, MM, SP
dsPIC33FJ06GS202	28	6	1K	2	-	1	1	4	-	6 ch, 3 S&H	1	2	1	1	1	-	Y	SO, MM, SP
dsPIC33FJ16GS402	28	16	2K	3	-	2	2	6	-	8 ch, 4 S&H	-	-	1	1	1	-	Y	SO, MM, SP
dsPIC33FJ16GS404	44	16	2K	3	-	2	2	6	-	8 ch, 4 S&H	-	-	1	1	1	-	Y	ML, PT
dsPIC33FJ16GS502	28	16	2K	3	-	2	2	8	-	8 ch, 6 S&H*	1	4	1	1	1	-	Y	SO, MM, SP
dsPIC33FJ16GS504	44	16	2K	3	-	2	2	8	-	12 ch, 6 S&H*	1	4	1	1	1	-	Y	ML, PT
dsPIC33FJ32GS406	64	32	4K	4	-	4	4	12	1	1 ADC, 16 Ch, 5 S&H	-	-	2	2	2	-	Y	PT, MR
dsPIC33FJ64GS406	64	64	8K	4	-	4	4	12	1	1 ADC, 16 Ch, 5 S&H	-	-	2	2	2	-	Y	PT, MR
dsPIC33FJ32GS606	64	32	4K	4	-	4	4	12	2	2 ADC, 16 Ch, 6 S&H*	1	4	2	2	2	-	Y	PT, MR
dsPIC33FJ64GS606	64	64	9K	4	4	4	4	12	2	2 ADC, 16 Ch, 6 S&H*	1	4	2	2	2	1	Y	PT, MR
dsPIC33FJ32GS608	80	32	4K	4	-	4	4	16	2	2 ADC, 18 Ch, 6 S&H*	1	4	2	2	2	-	Y	PT
dsPIC33FJ64GS608	80	64	9K	4	4	4	4	16	2	2 ADC, 18 Ch, 6 S&H*	1	4	2	2	2	1	Y	PT
dsPIC33FJ32GS610	100	32	4K	4	-	4	4	18	2	2 ADC, 24 Ch, 6S&H*	1	4	2	2	2	-	Y	PT, PF
dsPIC33FJ64GS610	100	64	9K	4	4	4	4	18	2	2 ADC, 24 Ch, 6S&H*	1	4	2	2	2	1	Y	PT, PF

\*4 Msps devices

## dsPIC30F SMPS and Digital Power Conversion Family

Device	Pins	Flash Memory Kbytes	RAM Bytes	Timer 16-bit	Input Capture	Output Compare/Standard PWM	PS PWM	ADC 10-bit 2 Msps	Analog Comparator	UART	SPI	IC™	Package Code
dsPIC30F	28-44	6-12	256-512	2-3	0-1	1-2	4-8 ch	6-12 ch	2-4	1	1	1	SO, MM, SP, PT, ML

## dsPIC30F and dsPIC33F Motor Control and Power Conversion Family

Device	Pins	Flash Memory Kbytes	RAM Bytes	EEPROM Bytes	DMA # Ch	Timer 16-bit	Input Capture	Output Compare/Standard PWM	Motor Control PWM	Quadrature Encoder	ADC 10-/12-bit 1.1/.5 Msps	16-bit DAC	Analog Comp.	PMP	RTCC	UART	SPI	IC™	CAN
dsPIC30F	28-80	12-144	512-8192	1024-4096	-	3-5	4-8	2-8	6-8 ch	Yes	6-16 ch	-	-	-	-	1-2	1-2	1	0-2
dsPIC33F	20-100	12-256	1K-30K	-	0-8	3-9	4-8	2-8	6-8 ch	Yes	1-2 ADC, 4-24 ch	0-2	0-2	0-1	0-1	1-2	1-2	1-2	0-2

## 16-bit PIC24F Microcontrollers for Intelligent Power Supply Solutions

Device	Pins	Flash Memory Kbytes	RAM Kbytes	Timers	Input Capture	Output Compare/PWM	ADC 10-bit	Analog Comparator	UART	SPI	IC™	USB OTB
PIC24FJ64GA004	28-44	16-64	4-8	5	5	5	13	2	2	2	2	-
PIC24FJ64GB004	28-44	32-64	8	5	5	5	13	3	2	2	2	1
PIC24FJ256GB110	64-100	64-256	16	5	9	9	16	3	4	3	3	1

## 8-bit PIC10F, PIC12F and PIC16F Microcontrollers

Device	Pins	Flash Memory Kbytes	Self Read/Self Write	RAM Bytes	EE Bytes	Timer 8/16-bit	Comparator	PWM	ADC	UART	SPI	IC™
PIC10F206	6	0.75	-	24	-	1/0	1	-	-	-	-	-
PIC10F222	6	0.75	-	23	-	1/0	-	-	2 ch x 8-bit	-	-	-
PIC12F(HV)615*	8	1.75	-	64	-	2/1	1	1 x Half Bridge	4 ch x 10-bit	-	-	-
PIC12F617	8	3.5	Yes	128	-	2/1	1	1 x Half Bridge	4 ch x 10-bit	-	-	-
PIC16F(HV)616*	14	3.5	-	128	-	2/1	2	1 x Full Bridge	8 ch x 10-bit	-	-	-
PIC16F(LF)1827	18	7	Yes	384	256	4/1	2	1 x Full Bridge, 1 x Half Bridge, 2 x PWM	12 ch x 10-bit	1	2	2
PIC16F(HV)785*	20	3.5	-	128	256	2/1	2	1 x PWM	12 ch x 10-bit	-	-	-
PIC16F(LF)193X**	28/40/44	28	Yes	1024	256	4/1	2	2 x Full Bridge, 1 x Half Bridge, 2 x PWM	14 ch x 10-bit	1	1	1

\*Internal shunt regulator for high voltage V<sub>DD</sub> support.

\*\*Has LCD segment driver; this row shows the superset products features.

# Product Tables

## 8-bit PIC18F Microcontrollers

Device	Pins	Flash Memory Kbytes	RAM Kbytes	Timer 8/16-bit	CCP/ECCP	ADC	Comparator	UART	MSSP	USB	LCD Segments
PIC18FXXK22	20-80	8-128	0.2-4	6/5	7/3	10-bit & 12-bit options	3	2	2	-	-
PIC18FXXK90	20-80	8-128	0.2-4	6/5	7/3	10-bit & 12-bit options	3	2	2	-	192
PIC18FXXK20	28-44	16-64	0.5-4	1/3	1/1	11 ch, 10-bit	2	1	1	-	-
PIC18FXXJ5X	28-80	32-128	4	4/4	7/3	13 ch, 10-bit & 12-bit options	3	2	2	1	-
PIC18FXXJ9X	64-80	8-128	1-4	1/3	2/0	12 ch, 10-bit & 12-bit options	2	2	1	-	192

## Analog Portfolio for Power Applications

Product Line	Example Devices	Description
LDOs	MCP1700/2/3, MCP1790/1, MCP1824/5/6/7, MCP1801/2/4, TC1301/2	Input voltage up to 30V. Output currents up to 1500 mA
Charge Pumps	MCP125X, TC766X	TC7660 20 mA, TC1252 adjustable and fixed, regulated, 120 mA
Switching Regulators	TC1303, MCP1603, MCP165X, MCP1640	Switcher/LDO combo, Buck regulator, Boost regulator
MOSFET Drivers	MCP140X, MCP141X, MCP14628, MCP14700	Low-side and Low-side/High-side drivers
Temperature Sensors	MCP9800/4, MCP9509, MCP9700	I <sup>2</sup> C™, Logic or voltage out. ±1°C accuracy nom.
Operational Amplifiers	MCP602X, MCP629X	RR I/O, Low Current/Low Voltage, 10 MHz and down
PWM Controllers	MCP1630, MCP1631	1 MHz, V and I modes, built-in driver

## Serial EEPROMs

Microchip serial EEPROMs provide industry-leading field reliability, E/W endurance, wide operating temperature range, versatile and tiny packaging options, short leadtimes and fast availability for all volumes in all business cycles. Broad offerings are available from 128-bit to 1 Mbit in all popular buses plus the UNI/O® single wire bus.

Density	Max Speed	SOIC SN	SOT-23 OT/TT	TSSOP ST	TDFN MNY/MC	PDIP P	MSOP MS	SOIJ SM	DFN MF	SC70 LT	T092 TO	Wafer W/S/WF	WLCSP CS
		5x6	3x3	3x6.5	2x3	8x9.5	3x5	5x8	5x6	2x2	Die	Die	
<b>I<sup>2</sup>C™ Bus 1.7V-5.5V</b>													
128bit-2K	400 KHz	X	5	X	X	X	X			5		X	
4K-32K	400 KHz	X	5	X	X	X	X					X	X
64K	1 MHz	X	5	X	X	X	X	X				X	X
128K	1 MHz	X		X	X	X	X	X	X			X	X
256K	1 MHz	X		X		X	X	X	X			X	X
512K	1 MHz	X		X		X		X	X			X	X
1 Mbit	1 MHz	X				X		X					
<b>Microwire Bus 1.8V-5.5V</b>													
1K-16K	3 MHz	X	6	X	X	X	X					X	
<b>SPI Bus 1.8V-5.5V</b>													
1K-4K	10 MHz	X	6	X	X	X	X					X	
8K-64K	10 MHz	X		X	X	X	X					X	
128K, 256K	10 MHz	X		X		X		X	X			X	
512K	20 MHz	X		14		X		X	X			X	
1 Mbit	20 MHz					X		X	X			X	
<b>UNI/O® Single-Wire Bus 1.8V-5.5V</b>													
1K-16K	100 KHz	X	3		X	X	X				X	X	X

# Intelligent Power Development Systems: Accelerate Your Development

Microchip offers a number of development boards and advanced development tools which provide an easy and economical way to evaluate intelligent power supply solutions. Included with the development boards are software, documentation and hands-on exercises that allow users to quickly begin designing intelligent power solutions.

## MCP1630 Dual Synchronous Buck Regulator Board (MCP1630RD-DDBK1)



The MCP1630 Dual Synchronous Buck Regulator demo board is a dual output programmable power supply capable of 20A per output. Both outputs switch at 500 kHz 180° out of phase while powered from a +12V input source. Additional features include programmable output voltage, power good output indication, sequencing, overcurrent and overtemperature.

## MCP1630 Automotive Input Triple Output Converter Demo Board (MCP1630DM-DDBK4)



The MCP1630 Automotive Input Triple Output Converter Demo Board demonstrates Microchip's high-speed PWM used for automotive applications. When specified with a microcontroller, the MCP1630 will control the power system duty cycle to provide three regulated output voltages of 3.3V at 1.2A, 1.2V at 600 mA and 4.7V at 150 mA. The PIC12F683 microcontroller is used to provide the reference voltage, On/Off of converter using push button SW1 and oscillator pulses at switching frequency of 250 kHz. The MCP1630 generates a duty cycle based on various external inputs. External signals include the input oscillator pulses, reference voltage from the PIC12F683 MCU and the feedback voltage.

## dsPICDEM™ SMPS Buck Development Board (DM300023)



This development board provides an easy and economical way to evaluate the dsPIC30F202X/1010 SMPS and digital power conversion family of components for buck converter operation in synchronous or asynchronous modes and transient response for dynamic output load. The board includes a socketed dsPIC30F2020 device connected to power devices and circuitry for controlling dual independent low-power DC-to-DC synchronous buck converter circuits. In addition, it supports debug and serial communication circuitry for designs using potentiometers to simulate application features such as voltage trip, remote voltage sense, voltage tracking and current sharing.

## 16-bit 28-pin Starter Board (DM300027)



This low-cost, 16-bit, 28-pin starter development board supports 28-pin SDIP dsPIC30F, dsPIC33F and PIC24 devices with 3.3/5V operation.

This board is an ideal prototyping tool to help validate key design requirements using these MCUs and DSCs. This board features UART Communication via a USB bridge, MPLAB® ICD 3 In-Circuit Debugger, PICKIT™ 3 Starter Kit support. Headers are available to access all device I/O pins.

## Explorer 16 Development Board (DM240001)



The Explorer 16 is a low-cost, efficient development board to evaluate the features and performance of Microchip's 16-bit PIC24F and PIC24H MCU, dsPIC33

DSC and 32-bit PIC32MX families. Interface with the MPLAB® ICD 3 In-Circuit Debugger or MPLAB REAL ICE™ In-Circuit Emulator to speed evaluation and prototyping of application circuitry. This board features an alphanumeric display and Microchip's TC1047A high accuracy analog output temperature sensor. The board supports plug-in-modules for 28-, 44- and 100-pin dsPIC DSC devices. A PICtail™ Plus connector on the board allows for easy system expansion.

## Buck/Boost Converter PICtail™ Plus Card (AC164133)



A low-cost development platform for dsPIC33F "GS" SMPS devices, the buck/boost converter PICtail Plus card has two buck stage outputs and one boost stage output. The buck/boost converter operates from an input supply of +9V to +15V DC. Various performance measures like digital control loop performance of power conversion, dynamic load performance, multi-phase buck and synchronous buck converter operation, parallel operation of two buck converters and multiple output control with a single dsPIC device can be evaluated for dsPIC33F "GS" SMPS solutions. This board can be used with either the Explorer 16 board or the 16-bit 28-pin starter board and the dsPIC33F SMPS and digital power conversion devices.

# Advanced Development Tools and Reference Designs

## Digital Pure Sine Wave Uninterruptible Power Supply (UPS) Reference Design



The Digital Pure Sine Wave Uninterruptible Power Supply (UPS) Reference Design is based on the dsPIC33F “GS” series of digital-power Digital Signal Controllers (DSCs).

This reference design demonstrates how digital-power techniques when applied to UPS applications enable easy modifications through software, the use of smaller magnetics, intelligent battery charging, higher efficiency, compact designs, reduction in audible and electrical noise via a purer sine-wave output, USB communication and low-cost overall bill-of-materials.

## Digital Power Interleaved PFC Reference Design



This reference design provides an easy method to evaluate the power, and features of SMPS dsPIC® Digital Signal Controllers for an Interleaved Power Factor Correction application.

The Interleaved PFC reference design unit works with universal input voltage range and produces a single high voltage DC output up to 350W of power.

## AC/DC Reference Design



This board is a full-featured 300W (5V/23A and 3.3V/69A) power supply utilizing PFC and implementing one dsPIC SMPS device for the primary controller and one for the secondary

controller. The board also has a universal AC input with active power factor correction followed by two stages of DC/DC power conversion. The first stage converts the high-voltage DC to a 12V DC bus via a zero voltage transition full-bridge converter incorporating secondary side synchronous rectification.

Contact your local Microchip sales representative to arrange a demonstration of the AC/DC reference design.

## Quarter Brick DC/DC Converter Reference Design



Microchip’s quarter brick DC/DC converter uses a single dsPIC33F “GS” digital power digital signal controller (DSC) to control a phase shifted full bridge (PSFB) topology.

Using digital control techniques the dsPIC DSC enables efficiencies as high as 94%. The reference design works with standard telecom inputs of 36-76V DC and outputs 12V DC at 200W of power while conforming to the industry standard quarter brick size.

## DC/DC LLC Resonant Converter Reference Design



Using a single dsPIC33F “GS” digital signal controller (DSC) to control an LLC resonant topology, the DC/DC LLC resonant converter reference design achieves up to 95% efficiency

while providing high voltage isolation. Full digital control by the dsPIC enables Zero Voltage Switching on the half bridge and Zero Current Switching on the synchronous rectifier, which in turn enables the design’s high efficiency. The reference design takes 350-420V DC in and converts it to 12V at 200W output power, while maintaining 4 kV of input to output isolation.

## Digital LED Lighting Development Kit



The Digital LED Lighting Development Kit showcases the benefits of a digitally controlled LED lighting system. A single dsPIC33 “GS” DSC

is able to control a buck or boost power stage to power LED strings and at the same time implement advanced communication. The kit includes a baseboard with a dsPIC33 “GS” DSC and two power stage daughter cards, a buck and a boost. Each daughter card can power either the on-board LED strings or connect to external LED strings. The dsPIC DSC’s digital control enables both intelligent dimming and DMX512 communication to be done using a single controller chip.

## Grid Connected Solar Micro Inverter Reference Design



This reference design uses a single dsPIC33F “GS” digital power DSC to showcase a fully digital grid connected micro inverter system. The

board works with any 220 Watt solar panel between 25 and 55V DC and Microchip offers two versions to connect to either an 110V or 220V grid. The dsPIC33F digitally controls the power conversion stages, maximum power point tracking, grid fault detection and grid synchronization through software, enabling greater efficiency and simpler board design.

**Additional information for all reference designs is available at: [www.microchip.com/smcs](http://www.microchip.com/smcs).**

# Intelligent Power Supply Training and Resources

## Making Your Power Applications Intelligent The Easy Way!

Log on to [www.microchip.com/webseminars](http://www.microchip.com/webseminars) for FREE web seminars on Intelligent Power Supply designs.

Web Seminar Title	Language	Duration
Quarter Brick Phase Shifted Full Bridge DCDC Converter	English	20 min
LLC Resonant Converter Reference Design Using the dsPIC® DSC	English	20 min
Microchip's Grid Connected Solar Microinverter Reference Design	English	14 min
Controlling High Brightness LEDs using the dsPIC® DSC	English	12 min
Control System Design for Power Converters	English	21 min
Switch Mode Power Supply Topologies – the Forward Converter	English	26 min
SMPS Topologies – The Buck Converter	English	24 min
Switch Mode Power Supplies (SMPS) Part 1	Japanese	23 min
Introduction to Switch Mode Power Supplies (SMPS)	English	25 min
SMPS Components and Their Effects on System Design	English	31 min
SMPS Buck Converter Design Example	English	12 min
Introduction to SMPS Control Techniques	English	22 min
Advanced SMPS Topics	English	20 min
Introduction to the dsPIC® SMPS (Part 1)	English	20 min
Introduction to the dsPIC® SMPS (Part 2)	English	25 min
Building a dsPIC® DSC SMPS System	English	10 min
Designing Intelligent Power Supplies	English	30 min
Developing Intelligent Power Systems Using the MCP1630 High-speed PWM	English	20 min
Lithium-Ion Battery Charging: Techniques and Trade-offs	English	20 min
Offline UPS Reference Design Using the dsPIC® DSC	English	30 min

## Want to Learn From an Expert?

Log on to [www.microchip.com/RTC](http://www.microchip.com/RTC) and sign up for a formal hands-on session taught by Microchip experts. You can learn the theories and put them into practice. Additional classes are available covering various topics such as device architecture, peripheral configuration and device programming, C language, development tools, analog products and their usage.

## Need Design Assistance?

Visit [www.microchip.com/partners](http://www.microchip.com/partners) for a directory of third-party consultants and designers that can help with your intelligent power solutions design

# Intelligent Power Supply Training and Resources

## Intelligent Power Solution Application Notes/User Manuals/Software

Intelligent Power Solution Application	Document	Description
AC-DC	AN701	Switch Mode Battery Eliminator Based on a PIC16C72A
	AN954	Transformerless Power Supplies: Resistive and Capacitive
	AN1106	Power Factor Correction in Power Conversion Applications Using dsPIC® DSCs
	AN1278	Digital Power IPFC Reference Design
	DS70320	SMPS AC/DC Reference Design User's Guide
DC-DC and POL	AN216	DC/DC Converter Controller Using a PIC Microcontroller
	AN874	Buck Configuration High-Power LED Driver
	AN1025	Converting a 5.0V Supply Rail to a Regulated 3.0V
	AN1086	Switching Power Supply Design with the PIC16F785
	AN1335	Phase Shifted Full Bridge Quarter Brick DC/DC Converter Reference Design
	AN1336	LLC Resonant Converter Reference Design
	DS70181	dsPICDEM™ SMPS Buck Development Board User's Guide
	DS70336	Buck/Boost Converter PICTail™ Plus Daughter Board User's Guide
	TB053	Generating High Voltage Using the PIC16C781/782
	TB081	Soft-Start Controller for Switching Power Supplies
TB085	A Simple Circuit for Driving Microcontroller Friendly PWM Generators	
Battery Management	AN626	Lead Acid Battery Charger using the PIC14C000
	AN667	Smart Battery Charger with SMBus Interface
	AN947	Power Management in Portable Applications: Charging Lithium-Ion/Lithium-Polymer Batteries
	AN960	New Components and Design Methods Bring Intelligence to Battery Charger Applications
	AN1012	PIC16HV785: Programmable Lithium and Nickel Battery Charger
	AN1015	PIC16HV785: Programmable Lead Acid Battery Charger
Solar Inverter	AN1338	Solar Micro Inverter Reference Design
General	AN538	Using PWM to Generate Analog Output
	AN1035	Designing with HV Microcontrollers
	AN1114	Switch Mode Power Supply (SMPS) Topologies (Part I)
	AN1207	Switch Mode Power Supply (SMPS) Topologies (Part II)
	AN1279	Offline UPS Reference Design Using the dsPIC DSC
	DS01146	Compiled Tips 'N Tricks Booklet
	DS21913	Power Solutions Design Guide
	DS01036F	Lighting Applications Design Guide
	CEXXXX	Code examples for various peripheral and digital power control loops and techniques

### Getting Started

The Microchip web site ([www.microchip.com](http://www.microchip.com)) provides a wealth of information that can help you get started with your intelligent power design.

### Development Tools

Visit [www.microchip.com/tools](http://www.microchip.com/tools) to learn more about all of Microchip's software and hardware development tools.

### Intelligent Power Supply Design Center

If you would like more information about any of the solutions presented here, please visit the Microchip Intelligent Power Supply Design Center ([www.microchip.com/power](http://www.microchip.com/power)) for further details. The Design Center contains links to application notes, web seminars, user manuals and software referenced in this brochure.

## Support

Microchip is committed to supporting its customers in developing products faster and more efficiently. We maintain a worldwide network of field applications engineers and technical support ready to provide product and system assistance. In addition, the following service areas are available at [www.microchip.com](http://www.microchip.com):

- **Support** link provides a way to get questions answered fast: <http://support.microchip.com>
- **Sample** link offers evaluation samples of any Microchip device: <http://sample.microchip.com>
- **Forum** link provides access to knowledge base and peer help: <http://forum.microchip.com>
- **Buy** link provides locations of Microchip Sales Channel Partners: [www.microchip.com/sales](http://www.microchip.com/sales)

## Sales Office Listing

### AMERICAS

#### Atlanta

Tel: 678-957-9614

#### Boston

Tel: 774-760-0087

#### Chicago

Tel: 630-285-0071

#### Cleveland

Tel: 216-447-0464

#### Dallas

Tel: 972-818-7423

#### Detroit

Tel: 248-538-2250

#### Kokomo

Tel: 765-864-8360

#### Los Angeles

Tel: 949-462-9523

#### Santa Clara

Tel: 408-961-6444

#### Toronto

Mississauga, Ontario

Tel: 905-673-0699

### EUROPE

#### Austria - Wels

Tel: 43-7242-2244-39

#### Denmark - Copenhagen

Tel: 45-4450-2828

#### France - Paris

Tel: 33-1-69-53-63-20

#### Germany - Munich

Tel: 49-89-627-144-0

#### Italy - Milan

Tel: 39-0331-742611

#### Netherlands - Drunen

Tel: 31-416-690399

#### Spain - Madrid

Tel: 34-91-708-08-90

#### UK - Wokingham

Tel: 44-118-921-5869

## Training

If additional training interests you, then Microchip can help. We continue to expand our technical training options, offering a growing list of courses and in-depth curriculum locally, as well as significant online resources – whenever you want to use them.

- Regional Training Centers: [www.microchip.com/rtc](http://www.microchip.com/rtc)
- MASTERS Conferences: [www.microchip.com/masters](http://www.microchip.com/masters)
- Worldwide Seminars: [www.microchip.com/seminars](http://www.microchip.com/seminars)
- eLearning: [www.microchip.com/webseminars](http://www.microchip.com/webseminars)
- Resources from our Distribution and Third Party Partners [www.microchip.com/training](http://www.microchip.com/training)

### ASIA/PACIFIC

#### Australia - Sydney

Tel: 61-2-9868-6733

#### China - Beijing

Tel: 86-10-8528-2100

#### China - Chengdu

Tel: 86-28-8665-5511

#### China - Chongqing

Tel: 86-23-8980-9588

#### China - Hong Kong SAR

Tel: 852-2401-1200

#### China - Nanjing

Tel: 86-25-8473-2460

#### China - Qingdao

Tel: 86-532-8502-7355

#### China - Shanghai

Tel: 86-21-5407-5533

#### China - Shenyang

Tel: 86-24-2334-2829

#### China - Shenzhen

Tel: 86-755-8203-2660

#### China - Wuhan

Tel: 86-27-5980-5300

#### China - Xiamen

Tel: 86-592-2388138

#### China - Xian

Tel: 86-29-8833-7252

#### China - Zhuhai

Tel: 86-756-3210040

### ASIA/PACIFIC

#### India - Bangalore

Tel: 91-80-3090-4444

#### India - New Delhi

Tel: 91-11-4160-8631

#### India - Pune

Tel: 91-20-2566-1512

#### Japan - Yokohama

Tel: 81-45-471- 6166

#### Korea - Daegu

Tel: 82-53-744-4301

#### Korea - Seoul

Tel: 82-2-554-7200

#### Malaysia - Kuala Lumpur

Tel: 60-3-6201-9857

#### Malaysia - Penang

Tel: 60-4-227-8870

#### Philippines - Manila

Tel: 63-2-634-9065

#### Singapore

Tel: 65-6334-8870

#### Taiwan - Hsin Chu

Tel: 886-3-6578-300

#### Taiwan - Kaohsiung

Tel: 886-7-213-7830

#### Taiwan - Taipei

Tel: 886-2-2500-6610

#### Thailand - Bangkok

Tel: 66-2-694-1351

9/1/10

Microcontrollers • Digital Signal Controllers • Analog • Memory • Wireless

Information subject to change. The Microchip name and logo, the Microchip logo, dsPIC, MPLAB, PIC and UNI/O are registered trademarks and dsPICDEM, PICkit, PICtail and REAL ICE are trademarks of Microchip Technology Incorporated in the U.S.A. and other countries. All other trademarks mentioned herein are property of their respective companies. © 2010, Microchip Technology Incorporated. All Rights Reserved. Printed in the U.S.A. 11/10

DS01240D



**MICROCHIP**  
[www.microchip.com](http://www.microchip.com)

Microchip Technology Inc.  
2355 W. Chandler Blvd.  
Chandler, AZ 85224-6199