

高周波巻線チップインダクタ

WOUND CHIP INDUCTORS

FOR HIGH FREQUENCY

LB SERIES H TYPE



OPERATING TEMP. -25~+85°C

リフロー/REFLOW

特長 FEATURES

- ・実装上の特性を重視した形状。
- ・巻線タイプのため、High Qで自己共振周波数が高い。

- ・ Dimension attaches much importance to characteristics of mount case.
- ・ The product has excellent Q and SRF because, wound chip inductor.

用途 APPLICATIONS

- ・携帯電話や無線LAN等の高周波機器

- ・ Portable telephones and wireless LAN.

形名表記法 ORDERING CODE

1

形式	
LBH	高周波巻線チップインダクタ

3

包装	
B	単品
T	テーピング

4

公称インダクタンス[μ H]	
例	
3N9	0.0039
10N	0.01
R10	0.1

※N=小数点

5

インダクタンス許容差	
J	$\pm 5\%$
D	$\pm 0.5nH$

2

外径寸法 (mm)	
1608(0603)	1.6×0.8

6

当社管理記号	
△△△	標準品

△=スペース



1

Type	
LBH	Wound chip inductors for high frequency

3

Packaging	
B	Bulk
T	Tape & Reel

4

Nominal Inductance[μ H]	
example	
3N9	0.0039
10N	0.01
R10	0.1

*N=decimal point

5

Inductance Tolerances	
J	$\pm 5\%$
D	$\pm 0.5nH$

2

External Dimensions (mm)	
1608(0603)	1.6×0.8

6

Internal code	
△△△	Standard Products

△=Blank space

外形寸法 EXTERNAL DIMENSIONS

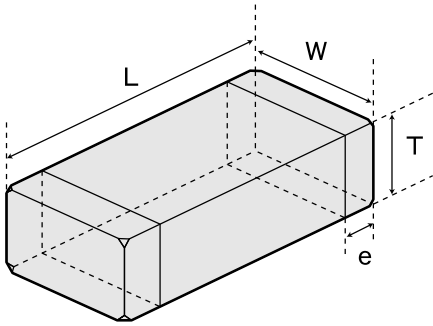

Type	L	W	T
LBH1608	1.6±0.1 (0.063±0.004)	0.8±0.1 (0.031±0.004)	0.8±0.1 (0.031±0.004)

Unit : mm(inch)

概略バリエーション AVAILABLE INDUCTANCE RANGE

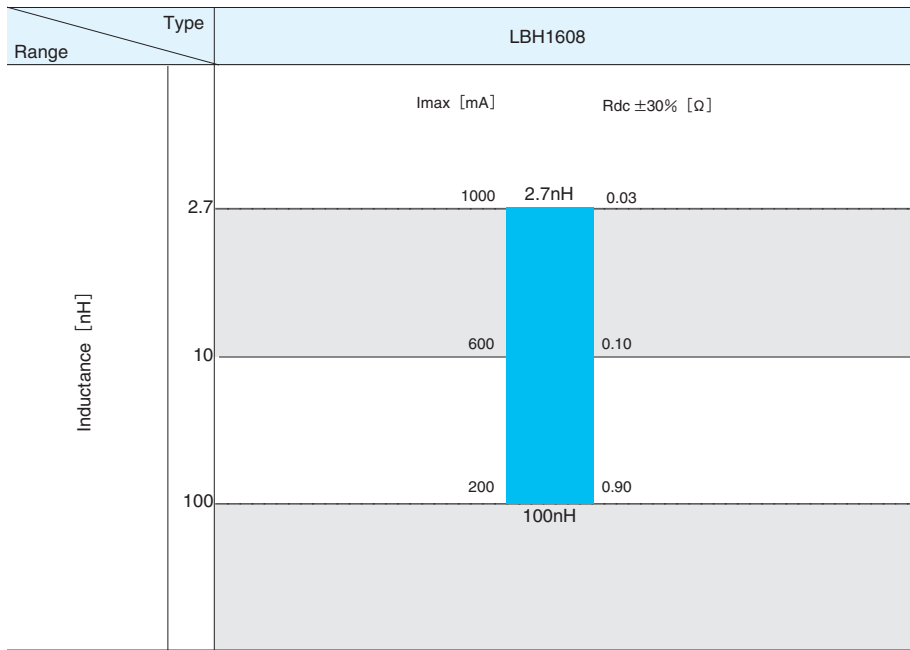

代 表 値 Examples	Inductance	Imax [mA]	Rdc ±30% [Ω]
	2.7nH	1000	0.03
	10nH	600	0.10
	100nH	200	0.90

セクションガイド
Selection Guide



etc

アイテム一覧
Part Numbers



特性図
Electrical Characteristics



梱包
Packaging



信頼性
Reliability Data



使用上の注意
Precautions



LBH1608 TYPE

形名 Ordering code	公称 インダクタンス Inductance [nH]	インダクタンス 許容差 Inductance Tolerance	Q min. (at 100MHz)	Q typ. 測定周波数[GHz]			自己共振 周波数 Self-resonant frequency [GHz] min.	直流抵抗 DC Resistance [Ω] ±30%	定格電流 Rated current [mA] max.	測定 周波数 Measuring frequency [MHz]
				0.8	1.5	2.0				
LBH1608□2N7D	2.7	±0.5nH	13	37	61	68	8.0	0.030	1000	100
LBH1608□3N3D	3.3		14	38	61	68	8.0	0.035	850	
LBH1608□3N9D	3.9		51	62	67	8.0	0.040	800		
LBH1608□4N7D	4.7		52	73	71	7.0	0.045	800		
LBH1608□5N6D	5.6		50	75	72	6.5	0.050	750		
LBH1608□6N8D	6.8		51	71	70	6.4	0.055	700		
LBH1608□8N2D	8.2	±5%	15	52	72	70	5.5	0.080	700	
LBH1608□10NJ	10			47	70	68	5.0	0.100	600	
LBH1608□12NJ	12			48	69	66	4.5	0.110	600	
LBH1608□15NJ	15			48	68	65	4.0	0.130	550	
LBH1608□18NJ	18		54	72	64	3.6	0.140	500		
LBH1608□22NJ	22		14	52	70	55	3.3	0.170	450	
LBH1608□27NJ	27			51	62	46	3.0	0.250	400	
LBH1608□33NJ	33			52	61	44	2.7	0.300	400	
LBH1608□39NJ	39			50	62	40	2.5	0.400	350	
LBH1608□47NJ	47			52	60	38	2.3	0.600	350	
LBH1608□56NJ	56			53	60	30	2.2	0.650	300	
LBH1608□68NJ	68		14	38	38	21	1.8	0.750	300	
LBH1608□82NJ	82			41	30	—	1.7	0.800	250	
LBH1608□R10J	100			32	18	—	1.7	0.900	200	

・注：形名の□には包装記号が入ります。 □ Please specify the packaging code.(T : Tape&Reel, B : Bulk)

特性図 ELECTRICAL CHARACTERISTICS

Q-周波数特性 Q-Characteristics (Measured by HP8720B)

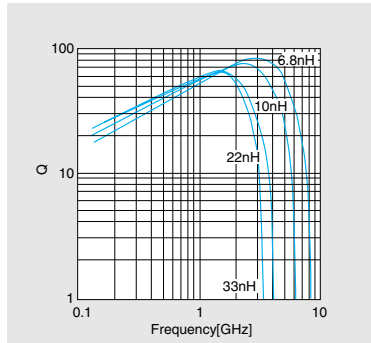

インピーダンス周波数特性 Impedance-vs-Frequency characteristics (Measured by HP8720B)

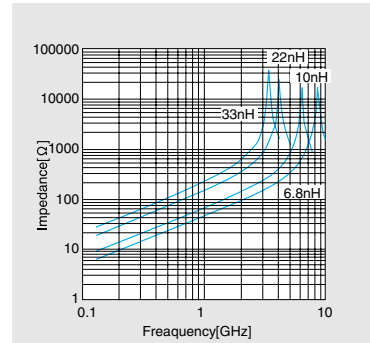

インダクタンス周波数特性 Inductance-vs-Frequency characteristics (Measured by HP8720B)

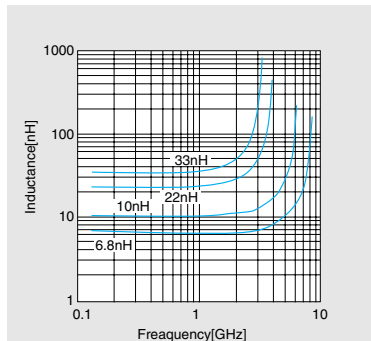

①標準数量 Standard Quantity

形式 Type	標準数量 Standard Quantity [pcs]	
	袋づめ Bulk / Bag	テーピング Tape&Reel
LB2518 / LBC2518	2000	2000
LB2016	2000	2000
LB2012	3000	3000
LBH1608 / LB1608	4000	4000

②テーピング材質 Tape material

エンボステープ Embossed tape
紙テープ(LBH1608) Card board carrier tape(LBH1608)

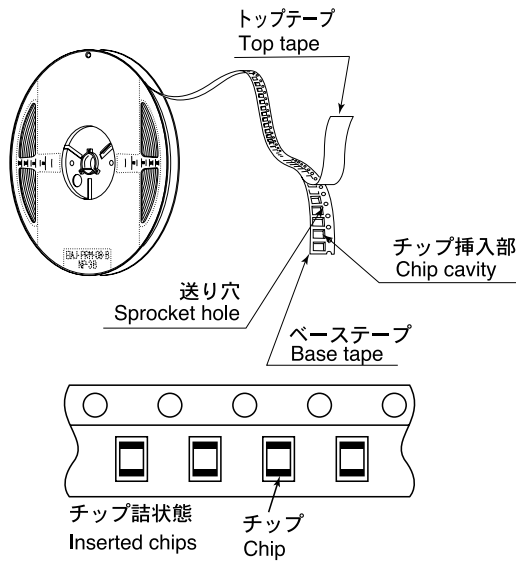

③テーピング寸法 Taping Dimensions

エンボステープ (8mm幅) Embossed Tape (0.315 inches wide)
紙テープ (8mm幅) Paper tape (0.315 inches wide)

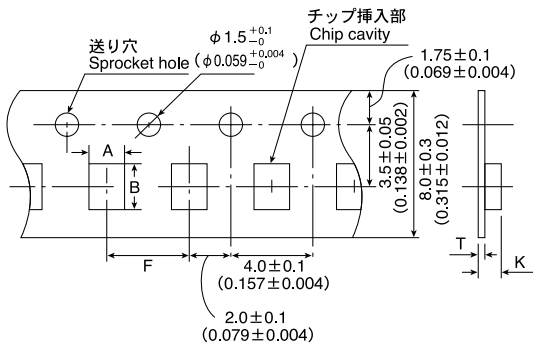

形式 Type	チップ挿入部 Chip Cavity		挿入ピッチ Insertion Pitch	テープ厚み Tape Thickness	
	A	B	F	K	T
LB2518	2.15±0.1	2.7±0.1	4.0±0.1	2.1	0.3
LBC2518	(0.085±0.004)	(0.107±0.004)	(0.157±0.004)	(0.083)	(0.012)
LB2016	1.9±0.1	2.2±0.1	4.0±0.1	2.15	0.3
	(0.075±0.004)	(0.087±0.004)	(0.157±0.004)	(0.085)	(0.012)
LB2012	1.5±0.2	2.3±0.2	4.0±0.1	2.0	0.3
	(0.059±0.008)	(0.091±0.008)	(0.157±0.004)	(0.079)	(0.012)
LBH1608	1.0±0.2	1.8±0.2	4.0±0.1	1.1max	1.1max
LB1608	(0.059±0.008)	(0.091±0.008)	(0.157±0.004)	(0.079)	(0.012)

Unit: mm (inch)

④リーダー部/空部 Leader and Blank Portion

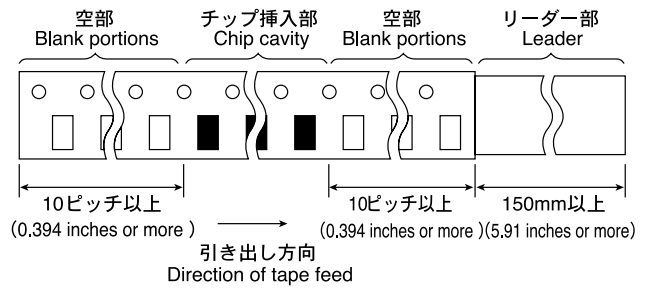

⑤リール寸法 Reel Size

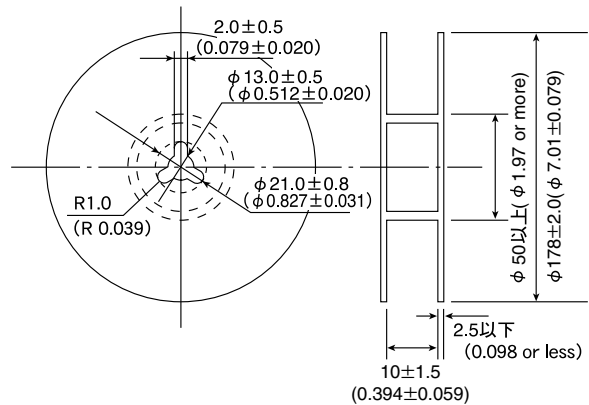

⑥トップテープ強度 Top Tape Strength

トップテープのはがし力は、下図矢印方向にて0.2~0.7Nとなります。
The top tape requires a peel-off force of 0.2 to 0.7N in the direction of the arrow as illustrated below.

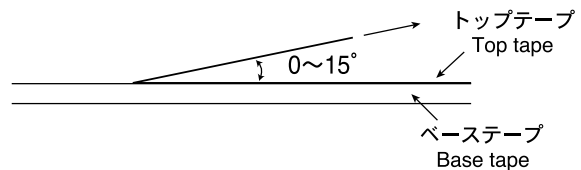

Item	Specified Value											Test Methods and Remarks	
	LER012 LER015	LEM2520	LEMC2520	LEMF2520	LEMC3225	LEMF3225	LB2518	LB2016	LB2012	LB1608	LBC2518		LBH1608
1. Operating temperature Range	-25~+85°C	-40~+85°C					-25~+85°C						
2. Storage	-40~+85°C					-25~+85°C							
3. Rated Voltage	Within the specified tolerance											<p>The maximum DC value having inductance decrease within 10% and temperature increases within 20°C by the application of DC bias.</p> <p>LBH1608 · LEM Series 5N6~R10: The maximum DC value having temperature increases within 20°C by the application of DC bias.</p>	
4. Inductance	Within the specified tolerance											<p>LER · LEM Series 5N6~R10 : Measuring equipment : Impedance analyzer (HP4291A or its equivalent) Measuring frequency : Specified frequency LER · LEM Series R12~221 : Measuring equipment : LCR Meter (HP4285A+42851A or its equivalent) Measuring frequency : Specified frequency</p> <p>LB · LBC Series : Measuring equipment : LCR Meter (HP4285A or its equivalent)</p> <p>LBH1608 Series : Measuring equipment : Impedance analyzer (HP4291A or its equivalent)</p>	
5. Q	Within the specified tolerance										<p>12~18 (at 100MHz) min</p> <p>LER · LEM Series 5N6~R10 : Measuring equipment : Impedance analyzer (HP4291A or its equivalent) Measuring frequency : Specified frequency LER · LEM Series R12~221 : Measuring equipment : LCR Meter (HP4285A+42851A or its equivalent) Measuring frequency : Specified frequency</p> <p>LB · LBC Series : Measuring equipment : LCR Meter (HP4285A or its equivalent)</p> <p>LBH1608 Series : Measuring equipment : Impedance analyzer (HP4291A or its equivalent)</p>		
6. DC Resistance	Within the specified tolerance											<p>LER · LEM · LB · LBC · LBH Series : Measuring equipment : low ohmmeter (A&D AD5812 or its equivalent)</p>	

Item	Specified Value											Test Methods and Remarks												
	LER012 LER015	LEM2520	LEMC2520	LEMF2520	LEMC3225	LEMF3225	LB2518	LB2016	LB2012	LB1608	LBC2518		LBH1608											
7. Self-Resonant Frequency	Within the specified tolerance											LER · LEM Series 5N6~R10 : Measuring equipment : Network analyzer (HP8720B or its equivalent) LER · LEM Series (Exclude LEM2520) R12~ : Measuring equipment : Impedance analyzer (HP4291A or its equivalent) LEM2520 : Measuring equipment : Network analyzer (Anritsu MS620J or its equivalent) LB · LBC Series : Measuring equipment : Impedance analyzer (HP4291A or its equivalent) LBH1608 Series : Measuring equipment : Network analyzer (HP8720B or its equivalent)												
8. Temperature Characteristic	$\Delta L/L \rightarrow$ Within $\pm 5\%$		$\Delta L/L \rightarrow$ Within $\pm 10\%$	$\Delta L/L \rightarrow$ Within $\pm 5\%$	$\Delta L/L \rightarrow$ Within $\pm 15\%$			$\Delta L/L \rightarrow$ Within $\pm 15\%$			$\Delta L/L \rightarrow$ Within $\pm 5\%$ * $\Delta L/L \rightarrow$ Within $\pm 0.5nH$ under 8.2nH	Change of maximum inductance deviation in step 1—5 * Exclude CM03MS series <table border="1"> <thead> <tr> <th>Step</th> <th>Temperature (°C)</th> </tr> </thead> <tbody> <tr> <td>1</td> <td>20</td> </tr> <tr> <td>2</td> <td>-25</td> </tr> <tr> <td>3</td> <td>20 (Reference temperature)</td> </tr> <tr> <td>4</td> <td>+85 (Maximum operating temperature)</td> </tr> <tr> <td>5</td> <td>20</td> </tr> </tbody> </table>	Step	Temperature (°C)	1	20	2	-25	3	20 (Reference temperature)	4	+85 (Maximum operating temperature)	5	20
Step	Temperature (°C)																							
1	20																							
2	-25																							
3	20 (Reference temperature)																							
4	+85 (Maximum operating temperature)																							
5	20																							
9. Resistance to Flexure of Substrate	No breakdown or damage											Warp: 2mm (LER012, LER015, LBC, LB) : 3mm (LEM2520, LEMC2520, LEMF2520, LEMC3225, LEMF3225) Test substrate: Printed board According to JIS C0051 												
10. Body Strength	No breakdown or damage											LER012 · LER015 Applied force : 15N Duration : 5sec. LB · LBC · LBH LEM2520 · LEMC2520 · LEMF2520 · LEMC3225 · LEMF3225 Applied force : 10N Duration : 10sec. LB1608 Applied force : 5N Duration : 10sec.												
11. Self Resonant Frequency	$\Delta L/L \rightarrow$ Within -10%											Measure inductance with application of rated current using LCR metre to compare it with the initial value. (* Excluding 5N6~R10)												

Item	Specified Value											Test Methods and Remarks
	LER012 LER015	LEM2520	LEMC2520	LEMF2520	LEMC3225	LEMF3225	LB2518	LB2016	LB2012	LB1608	LBC2518	
12. Adhesion of terminal electrode	Shall not come off PC board.	No detachment of electrode					Shall not come off PC board.					LER012 · LER015 Applied force : 15N Duration : 5 sec. Test substrate : Printed board LB · LBC · LBH LEM2520 · LEMC2520 · LEMF2520 · LEMC3225 · LEMF3225 Applied force : 10N to X and Y directions Duration : 5 sec. Test substrate : Printed board
13. Resistance to vibration	$\Delta L/L \rightarrow$ Within $\pm 5\%$ Q → R12~1R0 : 25min. 1R2~3R3 : 20min. $\Delta L/L \rightarrow$ Within $\pm 5\%$ Q → R12~100 : 30min. 120~220 : 20min.	$\Delta L/L \rightarrow$ Within $\pm 5\%$ No significant abnormality in appearance.				$\Delta L/L \rightarrow$ Within $\pm 10\%$ No significant abnormality in appearance.						LER · LEM · LB · LBC : According to JIS C5102 clause 8.2. Vibration type : A Directions : 2 hrs each in X, Y and Z directions. Total : 6 hrs Frequency range : 10 to 55 to 10 Hz (1min.) Amplitude : 1.5mm Mounting method : Soldering onto printed board (* Excluding 5N6-R10 LE Series) Recovery : At least 1 hr of recovery under the standard condition after the test, followed by the measurement within 2 hrs.

Item	Specified Value											Test Methods and Remarks
	LER012 LER015	LEM2520	LEMC2520	LEMF2520	LEMC3225	LEMF3225	LB2518	LB2016	LB2012	LB1608	LBC2518	
14.Drop test	No significant abnormality in appearance.	△L/L→Within±5% No significant abnormality in appearance.			△L/L→ Within±10% No significant abnormality in appearance.							LER・LEM : LER012・LER015 Drop test Impact material : concreta or vinyl tile Height : 1m Total number of drops : 10 times LEM2520・LEMC2520・LEMF2520・ LEMC3225・LEMF3225 Acceleration : 980m/sec ² Duration : 6msec Number of times : 6 sides × 3 times Mounting method : Soldering onto printed board (* Excluding 10N~R10) Recovery : At least 1 hr of recovery under the standard condition after the
15.Solderability	At least 90% of electrode											test, followed by the measurement within 2 hrs. LER・LEM : Solder temperature : 230±5°C Duration : 2±0.5sec. (LER012・LER015) 5±0.5sec. (LEM2520・ LEMC2520・LEMF2520・ LEMC3225・LEMF3225) Flux : Methanol solution with 25% of colophony LB・LBH : Solder temperature : 230±5°C Duration : 5±0.5sec Flux : Methanol solution with 25% of colophony

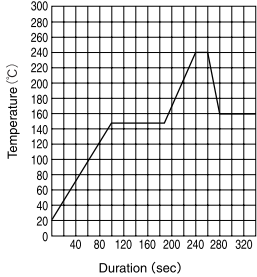
Item	Specified Value											Test Methods and Remarks
	LER012 LER015	LEM2520	LEMC2520	LEMF2520	LEMC3225	LEMF3225	LB2518	LB2016	LB2012	LB1608	LBC2518	
16. Resistance to soldering heat	No significant abnormality in appearance											Conduct following wave soldering twice. (LER012)  <p>Solder temperature : 260±5°C Duration : 5±0.5sec. Twice (LER015) 10±1sec. Once (LEM2520 · LEMC2520 · LEMF2520 · LEMC3225 · LEMF3225)</p> <p>LB · LBH : 3 times of reflow oven at 220 ± 5°C for 40sec. with peak temperature at 235± 5°C for 5sec.</p>
17. Resistance to solvent	No significant abnormality in appearance.											Solvent temperature : Room temperature Type of solvent : Chlorocarbon type (LEM2520 · LEMC2520 · LEMC3225) Isopropyl alcohol (LEMF2520 · LEMF3225 · LB · LBC) Cleaning conditions : Output : 20mW/cm ³ Frequency : 28kHz Duration : 1 min Conduct ultrasonic cleaning. (LEM2520 · LEMC 2520 · LEMC3225) 90s. Immersion and cleaning. (LEMF2520 · LEMF 3225 · LB · LBC)

Item	Specified Value											Test Methods and Remarks													
	LER012 LER015	LEM2520	LEMC2520	LEMF2520	LEMC3225	LEMF3225	LB2518	LB2016	LB2012	LB1608	LBC2518		LBH1608												
18. Resisittance to solvent	Δ/L/L→ Within±10% Q→ 5N6~18N : 10min. 22N~R10 : 15min. R12~1R0 : 20min. 25min. 1R2~3R3 : 30min. 20min. Δ/L/L→ Within±10% Q→ 10N~18N : 10min. 22N~R10 : 15min. R12~100 : 30min. 120~220 : 20min.	Δ/L/L→ Within±10% Q→ 10N : 10min. 12N~33N : 15min. 39N~R10 : 20min. R12~4R7 : 30min. 5R6~330 : 25min. 390~820 : 20min. 101 : 15min.	Δ/L/L→Within±10%									Δ/L/L→ Within±5% ※Δ/L/L→ within±0.5nH under 8.2 n H Δ/Q/Q→ within±20% ※Δ/Q/Q →within ±5 under 8.2 n H	Conditions for 1 cycle <table border="1"> <thead> <tr> <th>Step</th> <th>Temperature(C)①</th> <th>Temperature(C)②</th> <th>Duration(min)</th> </tr> </thead> <tbody> <tr> <td>1</td> <td>-25</td> <td>-40</td> <td>30</td> </tr> <tr> <td>2</td> <td>+85</td> <td>+85</td> <td>30</td> </tr> </tbody> </table> Temperature ① for : LER012 · LER015 Temperature ② for : LEM2520 · LEMC2520 · LEMF2520 · LEMC3225 · LEMF3225 Number of cycle : 100 cycle Recovery : At least 1 hr of recovery the standard condition after the removal from test chamber, followed by measurement within 2 hrs. LB · LBC · LBH : -40~+85°C, miaintain times 30min. ,100 cycle Recovery : At least 1 hr of recovery under the standard condition after the test, followed by the measurement within 2 hrs.	Step	Temperature(C)①	Temperature(C)②	Duration(min)	1	-25	-40	30	2	+85	+85	30
	Step	Temperature(C)①	Temperature(C)②	Duration(min)																					
1	-25	-40	30																						
2	+85	+85	30																						
19. Damp heat	Δ/L/L→ Within±10% Q→ 5R6~18N : 10min. 22N~R10 : 15min. R12~1R0 : 20min. 25min. 1R2~3R3 : 30min. 20min. Δ/L/L→ Within±10% Q→ 10N~18N : 10min. 22N~R10 : 15min. R12~100 : 30min. 120~220 : 20min.	Δ/L/L→ Within±10% Q→ 10N : 10min. 12N~33N : 15min. 39N~R10 : 20min. R12~4R7 : 30min. 5R6~330 : 25min. 390~820 : 20min. 101 : 15min.	Δ/L/L→Within±10%									Δ/L/L→ Within±5% ※Δ/L/L→ within±0.5nH under 8.2 n H Δ/Q/Q→ Within±20% ※Δ/Q/Q →within ±5 under 8.2 n H	Temperature : 60±2°C Humidity : 90~95%RH Duration : 1000 hrs Recovery : At least 1 hr of recovery the standard condition after the removal from test chamber, followed by measurement within 2 hrs.												

Item	Specified Value											Test Methods and Remarks	
	LER012 LER015	LEM2520	LEMC2520	LEMF2520	LEMC3225	LEMF3225	LB2518	LB2016	LB2012	LB1608	LBC2518		LBH1608
20.Loading under damp heat	ΔLL→ Within±10% Q→ R12~1R0 : 25min. 1R2~3R3 : 20min. ΔLL→ Within±10% Q→ R12~100 : 30min. 120~220 : 20min.	ΔLL→ Within±10% Q→ R12~4R7 : 30min. 5R6~330 : 25min. 390~820 : 20min. 101 : 15min.	ΔL/L→Within±10%									ΔLL→ Within±5% ※ΔLL→ within ±0.5nH under 8.2 n H △Q/Q→ Within±20% ※△QQ →within ±0.5 under 8.2 n H	LER · LEM · LB · LBC : Temperature : 60±2°C (Excluding nH range) Humidity : 90~95%RH Duration : 1000 hrs Applied current : Rated current Recovery : At least 1 hr of recovery the standard condition after the removal from test chamber, followed by measurement within 2 hrs.
21.Hihr temperature life test	ΔLL→ Within±10% Q→ 5R6~18N : 10min. 22N~R10 : 15min. 15min. R12~1R0 : 25min. 1R2~3R3 : 20min. ΔLL→ Within±10% Q→ 10N~18N : 10min. 22N~R10 : 15min. R12~100 : 30min. 120~220 : 20min.	ΔLL→ Within±10% Q→ 10N : 10min. 12N~33N : 15min. 39N~R10 : 20min. R12~4R7 : 30min. 5R6~330 : 25min. 390~820 : 20min. 101 : 15min.	ΔL/L→Within±10%									LER · LEM : Temperature : 85±2°C Duration : 1000 hrs Recovery : At least 1 hr of recovery the standard condition after the removal from test chamber, followed by measurement within 2 hrs.	
22.Loading at high temperature	ΔLL→ Within±10% Q→ R12~1R0 : 25min. 1R2~3R3 : 20min. ΔLL→ Within±10% Q→ R12~100 : 30min. 120~220 : 20min.		ΔL/L→Within±10%									ΔLL→ Within±5% ※ΔLL→ within±0.5nH under 8.2 n H △Q/Q→ Within±20% ※△QQ →within ±0.5 under 8.2 n H	LER · LB · LBC : Temperature : 85±2°C (Excluding nH range) Duration : 1000 hrs Applied current : Rated current Recovery : At least 1 hr of recovery the standard condition after the removal from test chamber, followed by measurement within 2 hrs.

Item	Specified Value											Test Methods and Remarks	
	LER012 LER015	LEM2520	LEMC2520	LEMF2520	LEMC3225	LEMF3225	LB2518	LB2016	LB2012	LB1608	LBC2518		LBH1608
23.Low temperature life test	ΔL/L→ Within±10% Q→ 5R6~18N : 10min. 22N~R10 : 15min. R12~1R0 : 20min. 25min. 1R2~3R3 : 30min. 20min. ΔL/L→ ±10%以内 Q→ 10N~18N : 10min. 22N~R10 : 15min. R12~100 : 30min. 120~220 : 20min.	ΔL/L→ Within±10% Q→ 10N : 10min. 12N~33N : 15min. 39N~R10 : 20min. R12~4R7 : 30min. 5R6~330 : 25min. 390~820 : 20min. 101 : 15min.	ΔL/L→Within±10%									ΔL/L→ Within±5% ※ΔL/L→ within±0.5nH 8.2 n H ΔQ/Q→ Within±20% ※ΔQQ →within ±5 under 8.2 n H	LER · LEM · LB · LBC · LBH Temperature : -40±2°C Duration : 1000 hrs Recovery : At least 1 hr of recovery the standard condition after the removal from test chamber, followed by measurement within 2 hrs.
24.Standard condition	"Standard condition" referred to herein defined as follows : 5 to 35°C of temperature, 45 to 85% relative humidity, and 86 to 106kPa of air pressure. When there are questions concerning measurement results : In order to provide correlation data, the test shall be conducted under condition of 20±2°C of temperature, 45 to 85% to 106kPa of air pressure. Unless otherwise specified all the test are conducted under the "standard condition"					Standard test condition : Unless otherwise specified, Temperature 20±15°C of temperature, 65±20% of relative humidity. When there are question concerning measurement result : In order to provide correlation date, the test shall be condition of 20±2°C of temperature, 65±5% relative humidity. Inductance is in accordance with our measured value.							

PRECAUTIONS

LER Type, LEM Type, LB Type

Stages	Precautions	Technical considerations
1.Circuit Design	<p>Operating environment,</p> <p>1.The products described in this specification are intended for use in general electronic equipment,(office supply equipment, telecommunications systems, measuring equipment, and household equipment). They are not intended for use in mission-critical equipment or systems requiring special quality and high reliability (traffic systems, safety equipment, aerospace systems, nuclear control systems and medical equipment including life-support systems,) where product failure might result in loss of life, injury or damage. For such uses, contact TAIYO YUDEN Sales Department in advance.</p>	
2.PCB Design	<p>Land pattern design</p> <p>1.Please contact any of our offices for a land pattern, and refer to a recommended land pattern of specifications.</p>	
3.Considerations for automatic placement	<p>Adjustment of mounting machine</p> <p>1.Excessive impact load should not be imposed on the products when mounting onto the PC boards.</p> <p>2.Mounting and soldering conditions should be checked beforehand.</p>	<p>1. When installing products, care should be taken not to apply distortion stress as it may deform the products.</p>
4.Soldering	<p>Wave soldering</p> <p>1.Please refer to the specifications in the catalog for a wave soldering.</p> <p>Reflow soldering</p> <p>1.Please contact any of our offices for a reflow soldering, and refer to the recommended condition specified.</p> <p>2.LER012 Type, LB Type</p> <p>Reflow soldering only.</p> <p>Lead free soldering</p> <p>1.When using products with lead free soldering, we request to use them after confirming of adhesion, temperature of resistance to soldering heat, etc. sufficiently.</p> <p>Recommended conditions for using a soldering iron</p> <p>Put the soldering iron on the land-pattern.</p> <p>Soldering iron's temperature - Below 350 °C</p> <p>Duration - 3 seconds or less</p> <p>The soldering iron should not directly touch the inductor.</p>	<p>1.If products are used beyond the range of the recommended conditions, heat stresses may deform the products, and consequently degrade the reliability of the products.</p>
5.Cleaning	<p>Cleaning conditions</p> <p>LB Type</p> <p>1.Washing by supersonic waves shall be avoided.</p>	<p>LB Type</p> <p>1.If washing by supersonic waves, supersonic waves may cause broken products.</p>
6.Handling	<p>Handling</p> <p>1.Keep the inductors away from all magnets and magnetic objects.</p> <p>Breakaway PC boards (splitting along perforations)</p> <p>1.When splitting the PC board after mounting inductors, care should be taken not to give any stresses of deflection or twisting to the board.</p> <p>2.Board separation should not be done manually, but by using the appropriate devices.</p> <p>Mechanical considerations</p> <p>1.Please do not give the inductors any excessive mechanical shocks.</p>	<p>1.There is a case that a characteristic varies with magnetic influence.</p> <p>1.Planning pattern configurations and the position of products should be carefully performed to minimize stress.</p> <p>1.There is a case to be damaged by a mechanical shock.</p>
7.Storage conditions	<p>Storage</p> <p>1.To maintain the solderability of terminal electrodes and to keep the packing material in good condition, temperature and humidity in the storage area should be controlled.</p> <p>• Recommended conditions</p> <p>Ambient temperature 0~40°C</p> <p>Humidity Below 70% RH</p> <p>The ambient temperature must be kept below 30°C Even under ideal storage conditions, solderability of products electrodes may decrease as time passes. For this reason, LE type inductors should be used within one year from the time of delivery.</p> <p>LER type, LB type</p> <p> Please should be used within 6 months from the time of delivery.</p> <p>LE type</p> <p> In case of storage over 6 months, solderability shall be checked before actual usage.</p>	<p>1. Under a high temperature and humidity environment, problems such as reduced solderability caused by oxidation of terminal electrodes and deterioration of taping/packaging materials may take place.</p>