

SIDE VIEW

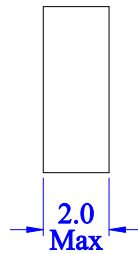

RECOMMENDED PCB LAYOUT

2 PAD LAYOUT

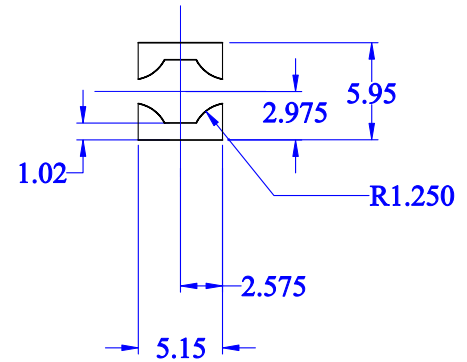

BOTTOM VIEW

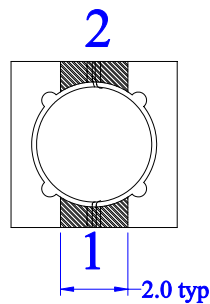

SCHEMATIC

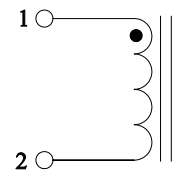

- Notes:
- 1) All Dimensions are in millimeters unless otherwise specified.
  - 2) All soldering surfaces to be coplanar within 0.10 millimeters.
  - 3) See Page 4 for Letter Designation Table
  - 4) PCB tolerances are +/- 0.2 unless stated otherwise.
  - 5) Part Marking: Line 1---3 Digit Marking-- (1st digit: Indicates inductance value per letter designation table on page 4); (2nd digit: Bi-weekly production date code); (3rd digit: Last digit of year produced) O (Indicates Size)
  - 6) RoHS Compliant

Cooper Electronic Technologies  
1225 Broken Sound Pkwy NW Suite F Boca Raton, FL 33487

Shielded Drum Core (SD20C) SMT Inductor Line  
2.0 mm height  
Mechanical Specifications

Size	Drawing Number:	SD20C-R Inductor Line
A	Revision Level:	B Sheet 3 of 29

## CUSTOMER INFORMATION

### 2.0mm Shielded Drum Core (SD20C) Family Table

Part Number	Rated Inductance (µH)	OCL nominal +/-20% (µH)	Part Marking Designator	<u>I<sub>RMS</sub> Amperes</u> for approximately a ΔT of 40°C. above 85°C ambient	<u>I<sub>SAT</sub> Amperes Peak</u> for approximately 30% rolloff (@ 20°C).	DCR (Ω) typ. @ 20°C.
SD20C-R47	0.47	0.490	A	3.59	4.00	0.0200
SD20C-1R2	1.20	1.21	B	3.07	2.55	0.0275
SD20C-1R5	1.50	1.69	C	2.88	2.15	0.0312
SD20C-2R2	2.20	2.25	D	2.45	1.87	0.0429
SD20C-3R3	3.30	3.61	E	2.17	1.47	0.0547
SD20C-4R7	4.70	4.41	F	2.05	1.33	0.0612
SD20C-6R2	6.20	6.25	G	1.89	1.12	0.0720
SD20C-8R2	8.20	8.41	H	1.61	0.966	0.1000
SD20C-100	10.0	9.61	J	1.53	0.903	0.1100
SD20C-150	15.0	15.21	K	1.25	0.718	0.1655
SD20C-220	22.0	22.09	L	1.12	0.596	0.2053
SD20C-330	33.0	32.49	M	0.913	0.491	0.3100
SD20C-470	47.0	47.61	N	0.745	0.406	0.4650
SD20C-680	68.0	68.89	O	0.610	0.337	0.6947
SD20C-820	82.0	82.81	P	0.576	0.308	0.7785
SD20C-101	100	98.01	Q	0.495	0.283	1.06
SD20C-151	150	151.3	R	0.435	0.228	1.37
SD20C-221	220	222.0	S	0.356	0.188	2.04
SD20C-331	330	327.6	T	0.294	0.155	2.99
SD20C-471	470	470.9	U	0.263	0.129	3.74
SD20C-681	680	681.2	V	0.216	0.107	5.56
SD20C-821	820	823.7	W	0.204	0.098	6.22
SD20C-102	1000	1004.9	X	0.172	0.088	8.73

**Electrical Requirement Notes:** 1) Test Parameters: 100KHz, 0.25Vrms      2) DCR @ 20°C

**Part number definition:**  
 First 4 characters = Product code and size.  
 Last 3 characters = Inductance in µH. R=decimal point.  
 If no R is present third character = # of zeros.

(1) Units supplied in tape and reel packaging. 13" reels 2900 parts per reel. Meets EIA-481 standard

<b>Cooper Electronic Technologies</b> 1225 Broken Sound Pkwy NW Suite F Boca Raton, FL 33487		
<b>Shielded Drum Core, (SD20C) SMT Inductor Line</b> <i>2.0 mm height.</i> Electrical Specifications		
SIZE A	Drawing Number: Revision Level: B	<b>SD20C-R Inductor Line</b> Sheet 4 of 29

Option Code (Suffix)	Description
-R	RoHS Compliant Version