

Power Choke Coil for Automotive application

- Series: **PCC-M0754M (MC)**
PCC-M0854M (MC)
PCC-M0850M (MC)
PCC-M1054M (MC)
PCC-M1050M (MC)

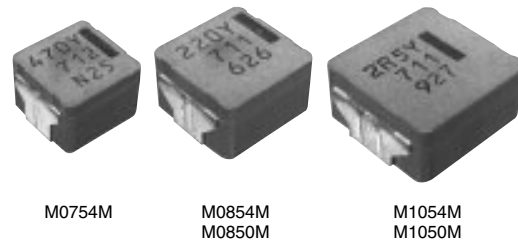

Realize high heat resistance and high reliability with metal composite core(MC)

Industrial Property : patents 21 (Registered 2/Pending 19)

■ Features

- High heat resistance : Operation up to 150 °C
- High-reliability : High vibration resistance due to newly developed integral construction and severe reliability condition of automotive application is covered
- High bias current : Excellent inductance stability by using ferrous alloy magnetic material(Fig.1)
- Temp. stability : Excellent inductance stability in wide temp. range (Fig.1)
- Low buzz noise : New metal composite core technology
- High efficiency : Low R_{DC} of winding and low eddy-current loss of the core

● Fig.1 Inductance v.s. DC current, Temp.
 ETQP5M470YFM(reference)

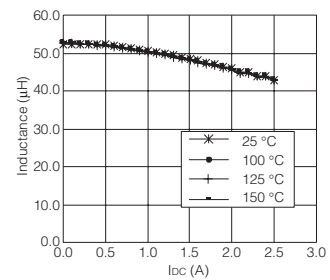

■ Recommended Applications

- Noise filter for various drive circuitry requiring high temp. operation and peak current handling capability
- DC-DC converters

■ Standard Packing Quantity

- 500 pcs./Reel

■ Explanation of Part Numbers

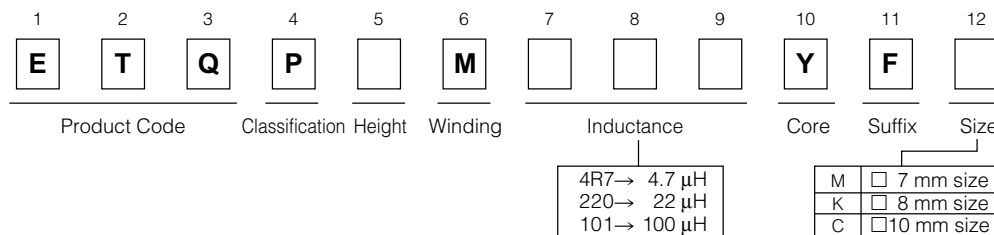

■ Temperature rating

Operating temperature range		Tc : -40 °C to +150 °C(Including self-temperature rise)
Storage condition	After PWB mounting	
	Before PWB mounting	Ta : -5 °C to +35 °C 85%RH max.

Design and specifications are each subject to change without notice. Ask factory for the current technical specifications before purchase and/or use. Should a safety concern arise regarding this product, please be sure to contact us immediately.

1. PCC-M0754M Series (ETQP5M□□□YFM)

■ Standard Parts

Series	Part No.	Inductance *1		Rated current	Reference current	DC resistance	
		L0 (μH)	Tolerance (%)	ΔT=15K*2 (A)	ΔT=40K*3 (A)	Typ. (mΩ)	Tolerance (%)
PCC-M0754M [7.5×7.0×5.4(mm)]	ETQP5M4R7YFM	4.7	±20	2.8	4.5	20.4	±10
	ETQP5M220YFM	22.7	±20	1.3	2.2	92	±10
	ETQP5M330YFM	34	±20	1.1	1.9	120	±10
	ETQP5M470YFM	48	±20	1.0	1.6	156	±10

(*1) Inductance is measured at 100 kHz.

(*2) Rated current defines actual value of DC current which is case temperature rise becomes 15 K.

(*3) Reference current defines actual value of DC current which is case temperature rise becomes 40 K.

■ Performance Characteristics (Reference)

● Inductance vs DC Current

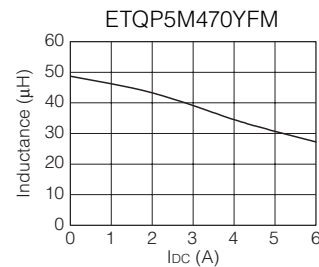
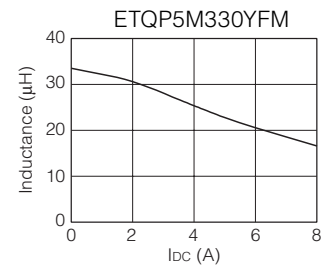
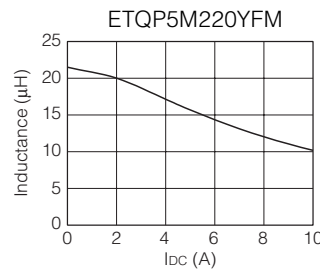
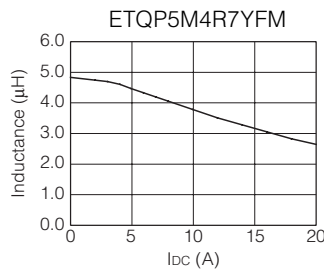

● Case Temperature vs DC Current*

PWB condition A : FR4, single layer PWB, t=1.6mm *our specification

PWB condition B : FR4, four layer PWB, t=1.6mm

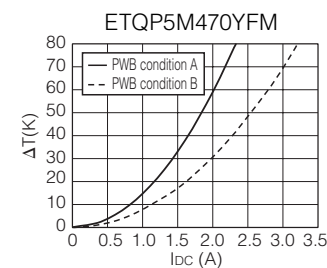
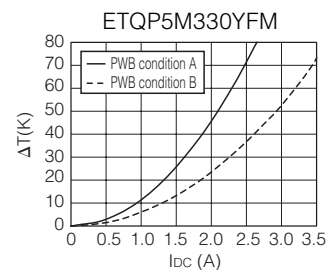
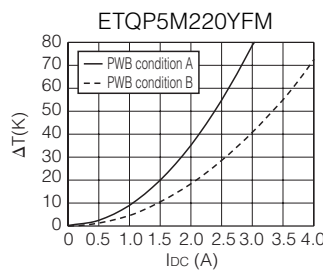
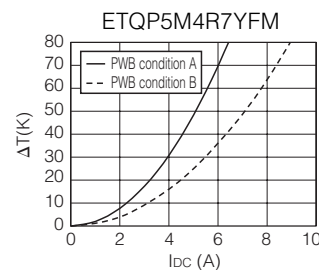

* Our temperature rise is specified with measurement of single layer PWB(condition A). Please refer to temperature rise curve V.S. current for the rated current (ΔT=15K) and Reference value (ΔT=40K). and when four layer PWB (condition B) is used, temperature rise is different from single layer PWB(condition A). Even we specify the rated current at our condition, the actual temperature rise of PCC may have different result due to thermal dissipation condition. We recommend customers to measure PCC temperature rise at application to confirm it.

Design and specifications are each subject to change without notice. Ask factory for the current technical specifications before purchase and/or use. Should a safety concern arise regarding this product, please be sure to contact us immediately.

00 Sep. 2010

2. PCC-M0854M/PCC-M0850M Series (ETQP5M□□□YFK/ETQP5M□□□YGK)

■ Standard Parts

Series	Part No.	Inductance *1		Rated current	Reference current	DC resistance	
		L0 (μH)	Tolerance (%)	ΔT=15K*2 (A)	ΔT=40K*3 (A)	Typ. (mΩ)	Tolerance (%)
PCC-M0854M [8.5×8.0×5.4(mm)]	ETQP5M2R5YFK	2.45	±20	4.5	7.5	7.6	±10
	ETQP5M220YFK	22	±20	1.6	2.6	63	±10
	ETQP5M470YFK	48	±20	1.1	1.8	125	±10
PCC-M0850M [8.5×8.0×5.0(mm)]	ETQP5M101YGK	100	±20	0.74	1.2	302	±10

(*1) Inductance is measured at 100 kHz.

(*2) Rated current defines actual value of DC current which is case temperature rise becomes 15 K.

(*3) Reference current defines actual value of DC current which is case temperature rise becomes 40 K.

■ Performance Characteristics (Reference)

● Inductance vs DC Current

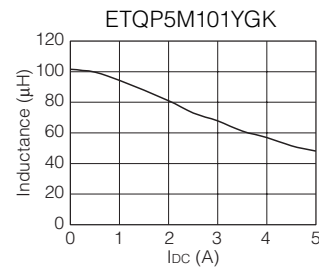
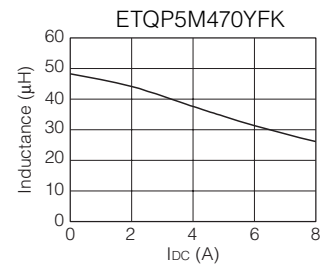
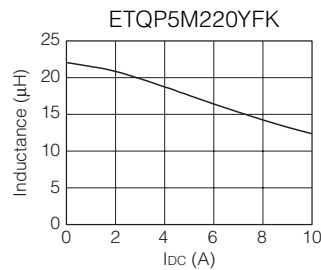
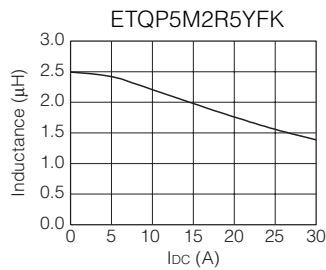

● Case Temperature vs DC Current*

PWB condition A : FR4, single layer PWB, t=1.6mm *our specification

PWB condition B : FR4, four layer PWB, t=1.6mm

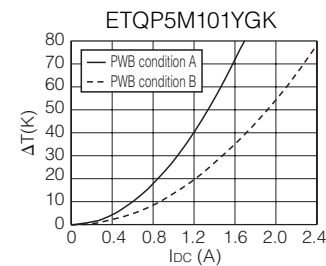
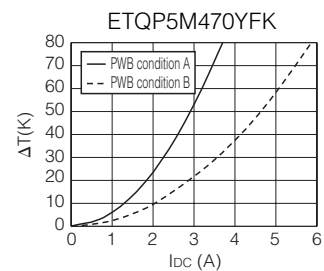
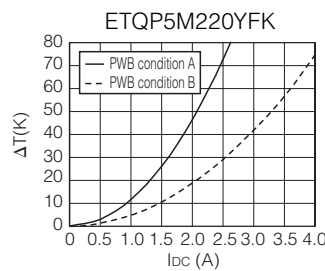
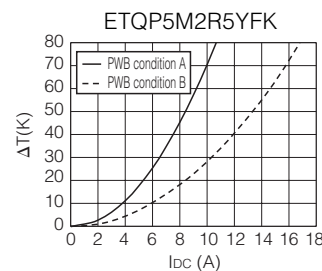

* Our temperature rise is specified with measurement of single layer PWB(condition A). Please refer to temperature rise curve V.S. current for the rated current (ΔT=15K) and Reference value (ΔT=40K). and when four layer PWB (condition B) is used, temperature rise is different from single layer PWB(condition A). Even we specify the rated current at our condition, the actual temperature rise of PCC may have different result due to thermal dissipation condition. We recommend customers to measure PCC temperature rise at application to confirm it.

Design and specifications are each subject to change without notice. Ask factory for the current technical specifications before purchase and/or use. Should a safety concern arise regarding this product, please be sure to contact us immediately.

00 Sep. 2010

3. PCC-M1054M/PCC-M1050M Series (ETQP5M□□□YFC/ETQP5M□□□YGC)

■ Standard Parts

Series	Part No.	Inductance *1		Rated current	Reference current	DC resistance	
		L0 (μH)	Tolerance (%)	ΔT=15K*2 (A)	ΔT=40K*3 (A)	Typ. (mΩ)	Tolerance (%)
PCC-M1054M [10.5×10.5×5.4(mm)]	ETQP5M2R5YFC	2.5	±20	6.0	10	5.3	±10
	ETQP5M3R3YFC	3.3	±20	5.1	8.6	7.1	±10
	ETQP5M4R7YFC	4.7	±20	4.4	7.2	10.2	±10
	ETQP5M100YFC	10	±20	2.9	4.7	23.8	±10
	ETQP5M220YFC	21.5	±20	2.1	3.4	45	±10
PCC-M1050M [10.5×10.5×5.0(mm)]	ETQP5M101YGC	97	±20	1.0	1.6	208	±10

(*1) Inductance is measured at 100 kHz.

(*2) Rated current defines actual value of DC current which is case temperature rise becomes 15 K.

(*3) Reference current defines actual value of DC current which is case temperature rise becomes 40 K.

■ Performance Characteristics (Reference)

● Inductance vs DC Current

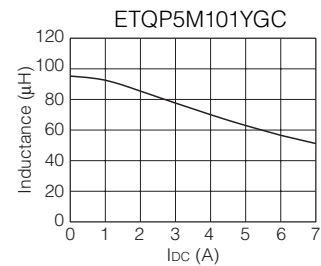
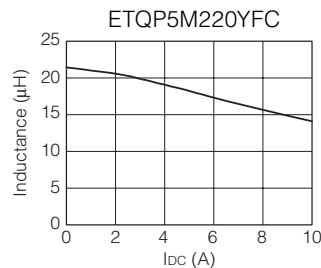
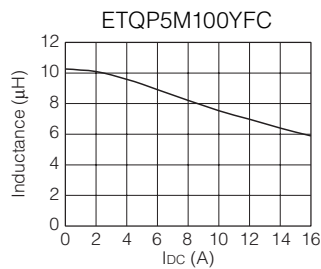
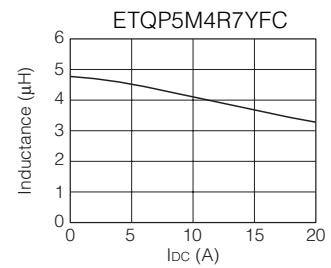
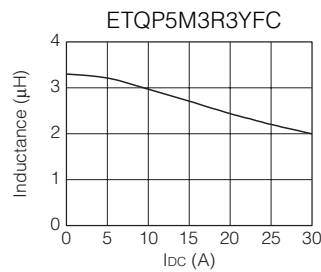
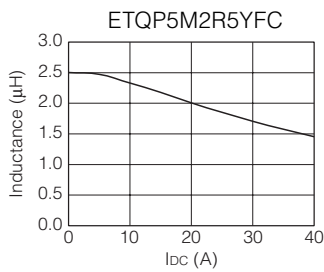

● Case Temperature vs DC Current*

PWB condition A : FR4, single layer PWB, t=1.6mm *our specification
 PWB condition B : FR4, four layer PWB, t=1.6mm

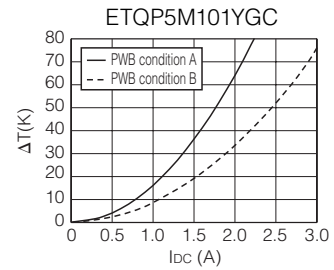
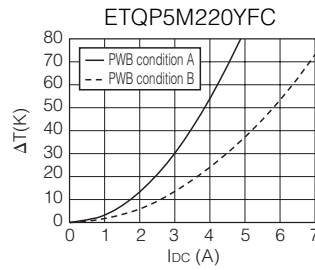
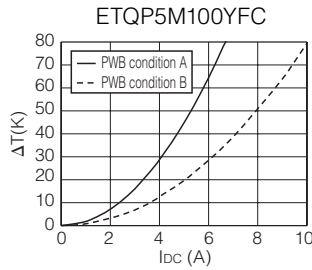
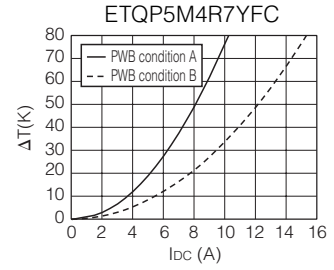
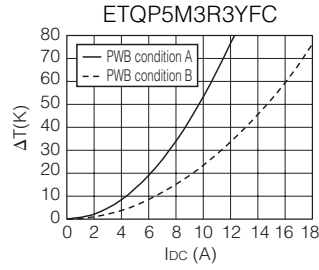
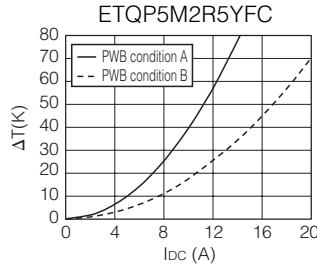

* Our temperature rise is specified with measurement of single layer PWB(condition A). Please refer to temperature rise curve V.S. current for the rated current (ΔT=15K) and Reference value (ΔT=40K). and when four layer PWB (condition B) is used, temperature rise is different from single layer PWB(condition A). Even we specify the rated current at our condition, the actual temperature rise of PCC may have different result due to thermal dissipation condition. We recommend customers to measure PCC temperature rise at application to confirm it.

- Dimensions in mm (not to scale)
Dimensional tolerance unless noted : ± 0.5

PCC-M0754M Series (ETQP5M□□□YFM)

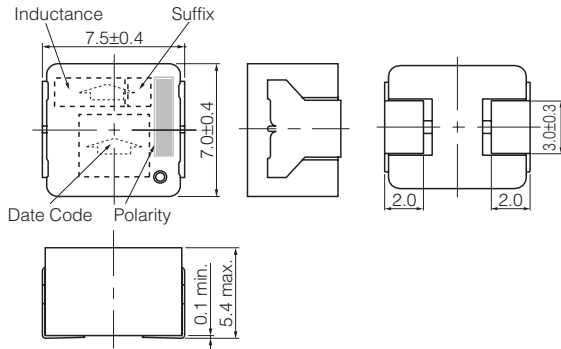

PCC-M0854M Series PCC-M0850M Series (ETQP5M□□□YFK/YGK)

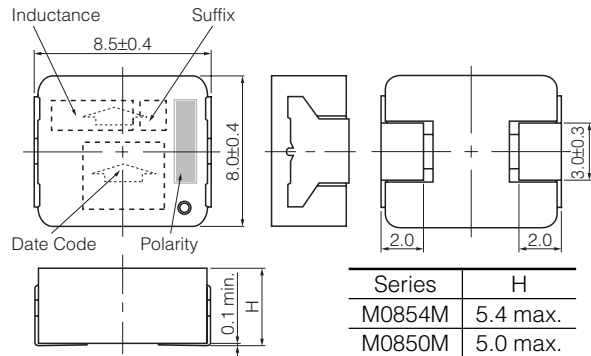

PCC-M1054M Series PCC-M1050M Series (ETQP5M□□□YFC/YGC)

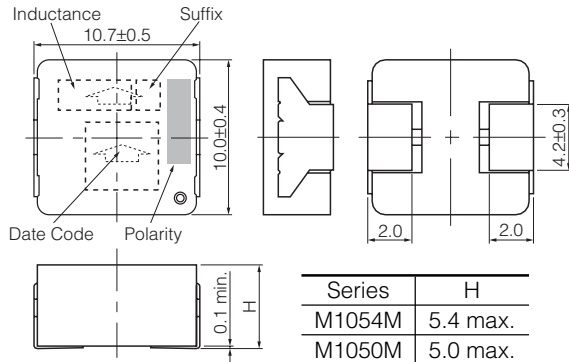

- Recommended Land Pattern in mm (not to scale)
Dimensional tolerance unless noted : ± 0.5

PCC-M0754M Series (ETQP5M□□□YFM)

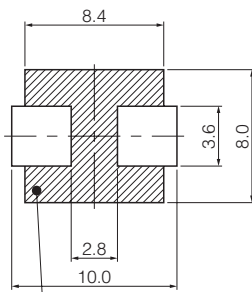

Don't wire on the pattern on shaded portion the PWB.

PCC-M0854M Series PCC-M0850M Series (ETQP5M□□□YFK/YGK)

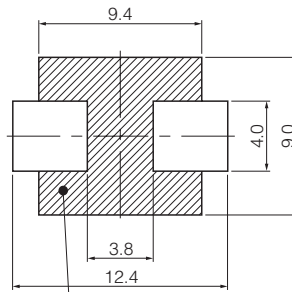

The same as the left.

PCC-M1054M Series PCC-M1050M Series (ETQP5M□□□YFC/YGC)

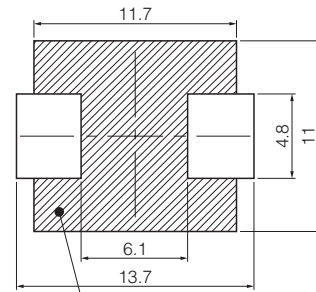

The same as the left.

- Packaging Methods Please see Pages 202 to 203
- Soldering Conditions Please see Page 204
- Safety Precautions Please see Pages 177 to 178

Design and specifications are each subject to change without notice. Ask factory for the current technical specifications before purchase and/or use. Should a safety concern arise regarding this product, please be sure to contact us immediately.