

*RoHS COMPLIANT

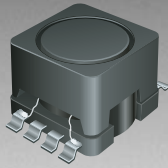

BOURNS®

Features

- Available in E6 series, E12 series optional
- High inductance up to 15 mH
- High current up to 5.6 A
- Gull wing leads
- RoHS compliant*

Applications

- Input/output of DC/DC converters
- Power supplies for:
 - Portable communication equipment
 - Camcorders
 - LCD TVs
 - Car radios

SRR0908 Series - SMD Shielded Power Inductors

Electrical Specifications

Bourns Part No.	Inductance 1 kHz		Q Ref.	Test Frequency (MHz)	SRF Min. (MHz)	RDC (ohms)	I rms Max. (A)	I sat Typ. (A)
	(µH)	Tol. %						
SRR0908-1R5ML	1.5	± 20	20	7.96M	65.0	0.014	5.60	10.00
SRR0908-2R7ML	2.7	± 20	20	7.96M	50.0	0.019	4.80	7.70
SRR0908-3R9ML	3.9	± 20	20	7.96M	35.0	0.021	4.40	6.60
SRR0908-5R6ML	5.6	± 20	18	7.96M	25.0	0.028	3.80	5.50
SRR0908-7R5ML	7.5	± 20	18	7.96M	15.0	0.032	3.40	4.60
SRR0908-100ML	10	± 20	33	2.52M	11.0	0.040	3.00	4.10
SRR0908-120ML	12	± 20	40	2.52M	11.0	0.050	2.50	4.00
SRR0908-150ML	15	± 20	45	2.52M	8.50	0.050	2.20	3.90
SRR0908-180ML	18	± 20	40	2.52M	8.50	0.075	2.00	3.80
SRR0908-220ML	22	± 20	35	2.52M	6.00	0.080	1.90	3.30
SRR0908-270ML	27	± 20	45	2.52M	6.00	0.090	1.80	2.90
SRR0908-330ML	33	± 20	40	2.52M	5.00	0.10	1.70	2.70
SRR0908-390ML	39	± 20	45	2.52M	5.00	0.14	1.50	2.40
SRR0908-470ML	47	± 20	40	2.52M	4.00	0.15	1.40	2.30
SRR0908-560ML	56	± 20	35	2.52M	3.00	0.17	1.35	2.10
SRR0908-680ML	68	± 20	30	2.52M	2.50	0.18	1.25	1.90
SRR0908-820ML	82	± 20	30	2.52M	2.40	0.26	1.05	1.90
SRR0908-101YL	100	± 15	40	0.796M	6.00	0.28	1.00	1.30
SRR0908-121YL	120	± 15	42	0.796M	5.70	0.34	0.90	1.10
SRR0908-151YL	150	± 15	45	0.796M	4.60	0.45	0.80	1.00
SRR0908-181YL	180	± 15	35	0.796M	4.20	0.50	0.70	1.00
SRR0908-221YL	220	± 15	35	0.796M	3.80	0.60	0.65	0.95
SRR0908-271YL	270	± 15	30	0.796M	3.40	0.70	0.60	0.75
SRR0908-331YL	330	± 15	30	0.796M	3.00	0.80	0.55	0.70
SRR0908-391YL	390	± 15	33	0.796M	2.60	1.00	0.50	0.65
SRR0908-471YL	470	± 15	30	0.796M	2.30	1.15	0.45	0.62
SRR0908-561YL	560	± 15	35	0.796M	2.20	1.50	0.38	0.55
SRR0908-681YL	680	± 15	30	0.796M	2.00	1.70	0.35	0.50
SRR0908-821YL	820	± 15	35	0.796M	1.90	2.20	0.32	0.45
SRR0908-102YL	1000	± 15	85	0.252M	1.80	2.50	0.30	0.41
SRR0908-152YL	1500	± 15	120	0.252M	1.30	4.00	0.25	0.35
SRR0908-222YL	2200	± 15	95	0.252M	1.00	5.00	0.20	0.29
SRR0908-332YL	3300	± 15	95	0.252M	0.90	8.00	0.15	0.24
SRR0908-472YL	4700	± 15	90	0.252M	0.80	12.00	0.12	0.19
SRR0908-682YL	6800	± 15	90	0.252M	0.60	16.50	0.10	0.16
SRR0908-822YL	8200	± 15	85	0.252M	0.50	24.00	0.10	0.14
SRR0908-103YL	10000	± 15	110	0.0796M	0.50	26.00	0.09	0.13
SRR0908-153YL	15000	± 15	130	0.0796M	0.40	40.00	0.08	0.12

Multiple windings possible (up to four windings).

General Specifications

Test Voltage 1 V
 Reflow Soldering ...230 °C, 50 sec. max.
 Operating Temperature .-40 °C to +125 °C
 (Temperature rise included)
 Storage Temperature...-40 °C to +125 °C
 Resistance to Soldering Heat
260 °C for 5 sec.

Materials

Core Ferrite DR and RI core
 Wire Enameled copper
 Base LCP
 Terminal Cu/Ni/Sn
 Adhesive Epoxy resin
 Rated Current
 Ind. drop 10 % typ. at Isat
 Temperature Rise
 40 °C max. at rated Irms
 Packaging 400 pcs. per reel

Product Dimensions

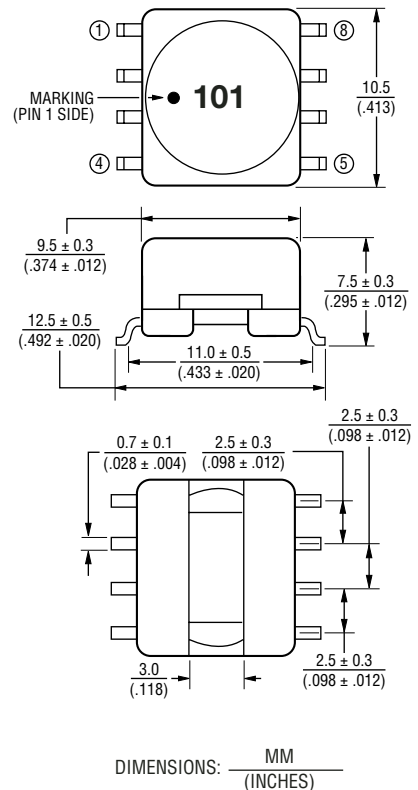

Recommended Layout

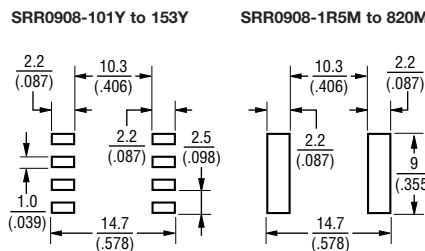

*RoHS Directive 2002/95/EC Jan 27 2003 including Annex Specifications are subject to change without notice. Customers should verify actual device performance in their specific applications.

SRR0908 Series - SMD Shielded Power Inductors

BOURNS®

Packaging Specifications

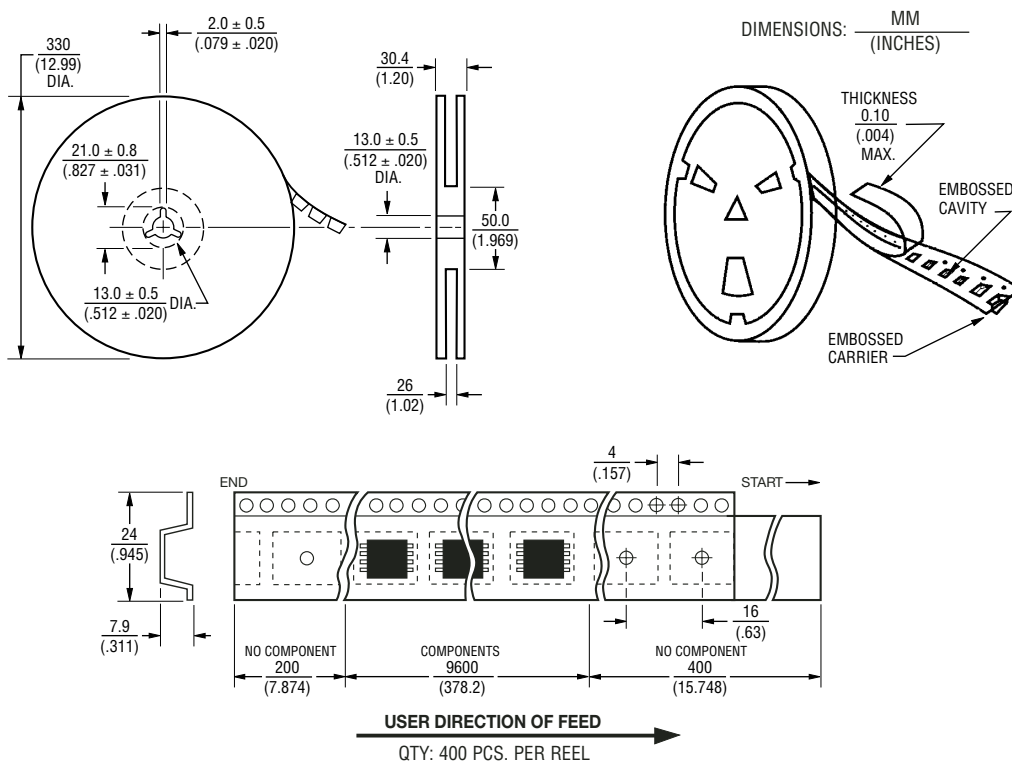

Electrical Schematic

SRR0908-1R5M to 820M

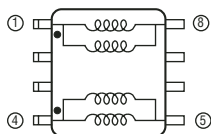

TOP VIEW (Typical Layout)

Termination of each individual winding may be either Pin 1, 2, 3, or 4.

Termination of opposite end of each individual winding may be either Pin 5, 6, 7, or 8

Windings will not be terminated to the same pin.

See "Recommended Layout" for SRR0908-1R5M to 820M.

SRR0908-101Y to 153Y

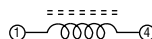

REV. 05/05

Specifications are subject to change without notice.

Customers should verify actual device performance in their specific applications.