

SERIES:

MGDQ2



3003 9th Avenue SW  
 PO Box 50  
 Watertown, SD 57201  
 Toll free: 888-978-2638  
 Ph: 605-886-3326  
 Fax: 605-886-8995



Low Profile, High Current Power Inductors

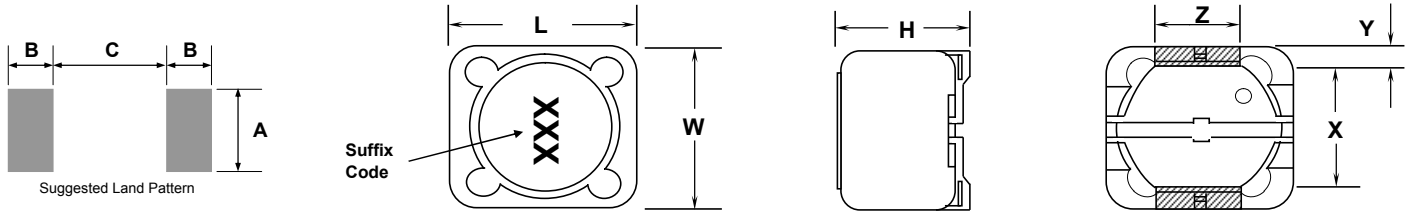

Series Number	Maximum Dimensions			Reference Dimensions						
	Units	L	W	H	X	Y	Z	A	B	C
MGDQ2	inches	0.256"	0.272"	0.197"	0.181"	0.043"	0.063"	0.069"	0.049"	0.171"
	[ mm ]	[ 6.50 ]	[ 6.90 ]	[ 5.00 ]	[ 4.60 ]	[ 1.10 ]	[ 1.60 ]	[ 1.75 ]	[ 1.25 ]	[ 4.35 ]

**Features:**

- High energy storage and low resistance
- Reliable surface mounting, flat top for pick and place.
- Smaller real estate than other common inductors.
- Robust temperature deflection to prevent damage during solder reflow.
- Tape and Reel mechanical specifications available upon request.
- Operating Temperature -40°C to +85°C.
- Highly resistive core for EMI suppression applications.

**Notes:**

- Inductance measured at 100kHz and 250mVrms.
- Isat is a maximum applied AC + DC current.
- Isat current is applied to produce a typical 35% drop in nominal inductance.
- Tolerance suffix of M = ±20%.
- DCR is a maximum at 20°C.



260°C Maximum reflow temperature per J-STD020C  
 Terminal Plating is Gold Flash over Ni

Schematic Diagram

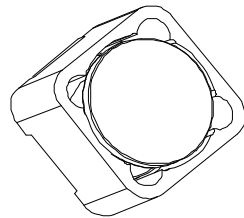
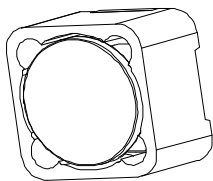
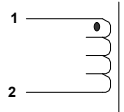

Contact CoEv for additional inductance values

MGDQ2				
Lead Free Part Number	L $\mu$ H	DCR $\Omega$	Isat A	Tolerance Suffix
	0.33			
	1.0			
	1.2			
	1.5			
	2.4			
	3.3			
	3.5			
	4.7			
	5.5			
	6.1			
	6.8			
	7.6			
MGDQ2-00001	10	0.12	1.35	M
MGDQ2-00002	12	0.13	1.22	M
MGDQ2-00003	15	0.18	1.11	M
MGDQ2-00004	18	0.24	1.02	M
MGDQ2-00005	22	0.27	0.91	M
MGDQ2-00006	27	0.30	0.82	M
MGDQ2-00007	33	0.33	0.74	M
MGDQ2-00008	39	0.37	0.69	M
MGDQ2-00009	47	0.52	0.62	M
MGDQ2-00010	56	0.56	0.58	M
MGDQ2-00011	68	0.63	0.51	M
MGDQ2-00012	82	0.71	0.46	M
MGDQ2-00013	100	1.03	0.42	M
MGDQ2-00014	120	1.15	0.38	M
MGDQ2-00015	150	1.68	0.35	M
MGDQ2-00016	180	1.87	0.32	M
MGDQ2-00017	220	2.08	0.29	M
MGDQ2-00018	270	2.37	0.26	M
MGDQ2-00019	330	2.67	0.23	M
MGDQ2-00020	390	2.94	0.22	M
MGDQ2-00021	470	3.93	0.20	M
MGDQ2-00022	560	5.43	0.18	M
MGDQ2-00023	680	7.32	0.17	M
MGDQ2-00024	820	8.24	0.15	M
MGDQ2-00025	1000	9.26	0.14	M

Specifications subject to change.

Call Toll Free: 888-978-2638 Website: [www.tycopowercomponents.com](http://www.tycopowercomponents.com)

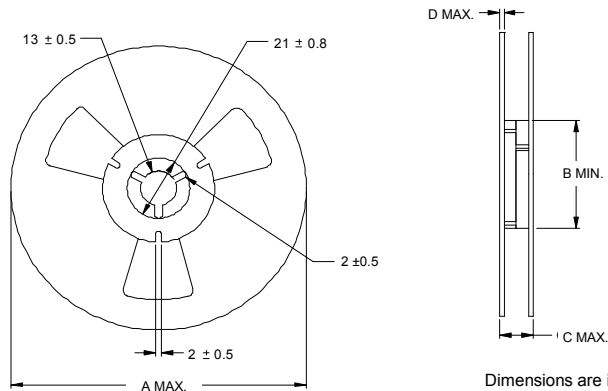

Dimensions are in millimeters unless specified.

Series Number	Reel dimensions				Reel Qty	Carton (Box) Qty.	Packaging Specification
	Units	A	B	C			
MGDQ2	in.	14.17"	3.94"	0.88"	1000	6000	90-0044
	[mm]	[360]	[100.0]	[22.4]			

PACKAGING NOTE: Only pressure sensitive cover tape is to be used.

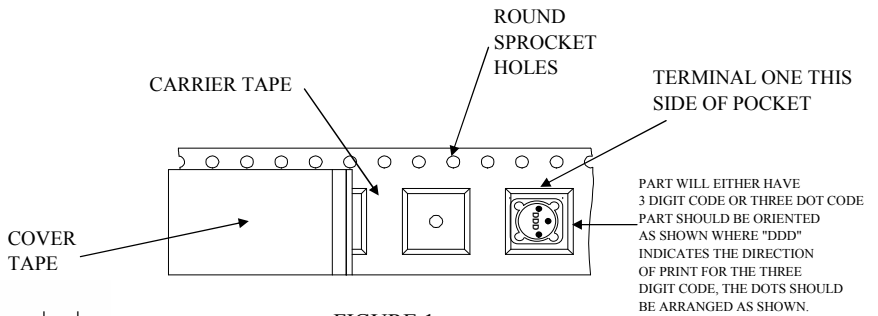
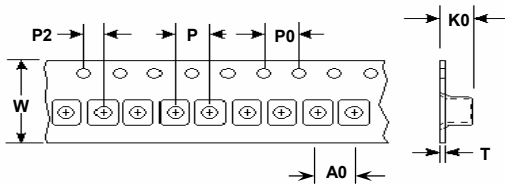

FIGURE 1  
CARRIER TAPE AND PART



Series	W ±0.3	P ±0.1	P0 ±0.1	P2 ±0.1	K0 ±0.05	T ±0.05	A0 ±0.1
MGDQ2	16.0	12.0	4.00	2.00	5.15	0.35	7.3



**Customer Packaging Specifications**  
For Print Distribution to Customers

Series	Revision
MGDQ2	A

Item	Specification	Test Method/Condition
<b>Environmental</b>		
Static Humidity	After exposure part remains within specified electrical parameters for L, Q and DCR.	Precondition at 25°C for 60 minutes. Expose parts to an environment of +40°C with 90 to 95% R.H. for 240 hours.
Storage Life	After exposure part remains within specified electrical parameters for L, Q and DCR.	Subject parts to an environment of 85°C 85% R.H. for 168 hours. After exposure allow parts to dry for 4 hours before measurements are taken.
Temperature Cycle	After exposure part remains within specified electrical parameters for L, Q and DCR.	10 cycles (Air to Air) 1 cycle shall consist of: 30 minutes exposure to +85°C 30 minutes exposure to -40°C Allow 20 minutes transition between extremes.
Temperature Shock	After exposure part remains within specified electrical parameters for L, Q and DCR.	10 cycles (Air to Air) 1 cycle shall consist of: 30 minutes exposure to -55°C 30 minutes exposure to +125°C 15 seconds maximum transition between temperatures
IR Reflow	10 seconds at 260°C max.	Post test parts shall pass all electrical specifications after reflow. There shall be no visible signs of solder flow or leakage from the part.
<b>General</b>		
Storage Temperature Range	-40°C to +85°C	
Operating Temperature Range	-40°C to +85°C	
Flammability	IEC 695-2-2	Withstands needle-flame test
<b>Other</b>		
Vibration	After exposure part remains within specified electrical parameters for L, Q and DCR.	1 cycle of 30 minutes of the following: 5 - 7 Hz constant displacement of 0.75 inches, 5 minutes 7 - 30 Hz constant acceleration of 1.5 Gs, 10 minutes 31 - 50 Hz constant displacement of 0.33 inches, 5 minutes 50 - 500 Hz constant acceleration of 1.2 Gs, 10 minutes
Mechanical Shock	After exposure part remains within specified electrical parameters for L, Q and DCR.	MGDQ2 Series - 500 Gs per axis, 2 directions
Solderability	Wetting shall cover 90% minimum of each termination	Dip pads in RMA flux, 63/37 solder (Sn/Pb) at 232°C for 5 seconds ±2 seconds.
Component Adhesion (Push Test)	Component shall withstand 6 lb. push force minimum without delaminating from mounting surface.	Apply and measure force with a digital force gauge set.
Resistance to Solvent		Withstands 6 minutes of alcohol.  Withstands 3 minutes forced spray Freon TMS
<b>Chemical</b>		
Ionic Contamination	Conductivity: pH: Chlorides: Sodium: Potassium:	11 µOhms/cm maximum 5.5 to 9 65 ppm maximum 20 ppm maximum 10 ppm maximum



**For Print Distribution to Customers**

Series	Revision
<b>MGDQ2</b>	<b>A</b>