

SMD Inductors(Coils) For Power Line(Wound)

Conformity to RoHS Directive

VLP Series VLP5610

FEATURES

- This is an SMD power inductor for power supplies that has an open magnetic path construction based on a low-height drum core (upright).
- User terminals are contact-formed on the bottom of the drum core using copper (finished with tin plating).
- It uses crosswise windings and supports large currents.
- It is lead-free compatible.
- With several variations in drum core height, users can choose the perfect product for their application.



APPLICATIONS

- LCD modules
- Cellular phones
- Hard disk drives

SHAPES AND DIMENSIONS

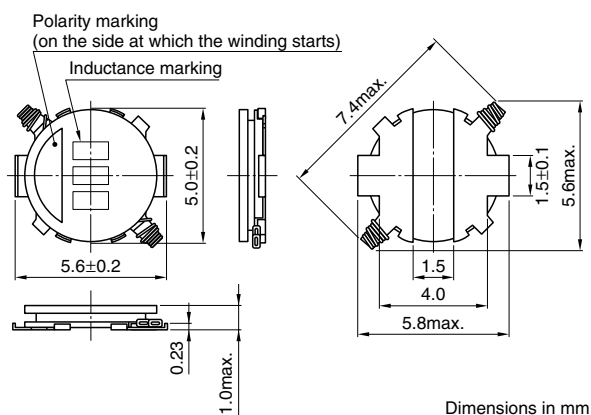

ELECTRICAL CHARACTERISTICS

Part No.	Inductance (μH)	Inductance tolerance (%)	Test frequency (kHz)	DC resistance (Ω)max.	Rated current(A)*	
					Based on inductance change	Based on temperature rise
VLP5610T-2R7M1R0	2.7	±20%	100	0.17	1.26 max.	1.05 typ.
VLP5610T-4R7MR90	4.7	±20%	100	0.24	1.08 max.	0.90 typ.
VLP5610T-6R8MR80	6.8	±20%	100	0.30	0.90 max.	0.80 typ.
VLP5610T-100MR65	10.0	±20%	100	0.45	0.72 max.	0.65 typ.
VLP5610T-150MR52	15.0	±20%	100	0.71	0.63 max.	0.52 typ.
VLP5610T-220MR45	22.0	±20%	100	0.96	0.50 max.	0.45 typ.
VLP5610T-330MR36	33.0	±20%	100	1.47	0.41 max.	0.36 typ.
VLP5610T-470MR29	47.0	±20%	100	1.93	0.36 max.	0.29 typ.

* Rated current: The rated current is the smaller of the values given based on the rate of inductance change (10% decrease from the initial value) or the temperature rise (temperature rise of 40°C caused by the heat generated by the product itself). Please note that the current applied must be DC.

- Conformity to RoHS Directive: This means that, in conformity with EU Directive 2002/95/EC, lead, cadmium, mercury, hexavalent chromium, and specific bromine-based flame retardants, PBB and PBDE, have not been used, except for exempted applications.

• All specifications are subject to change without notice.

TYPICAL ELECTRICAL CHARACTERISTICS INDUCTANCE vs. DC SUPERPOSITION CHARACTERISTICS

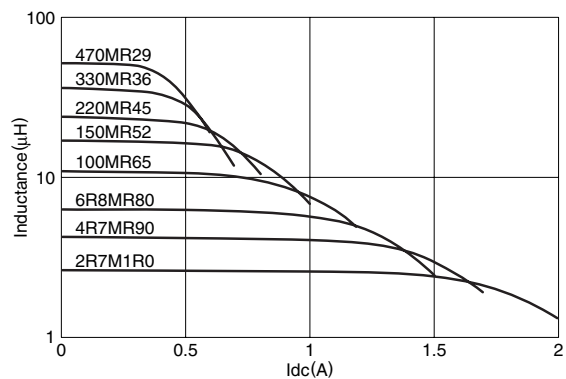

TEMPERATURE RISE CHARACTERISTICS

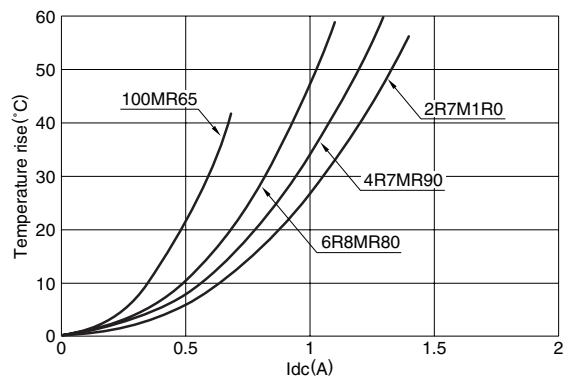

• All specifications are subject to change without notice.