

SMD Inductors(Coils) For Power Line(Multilayer, Magnetic Shielded)

Conformity to RoHS Directive

MLZ Series MLZ2012

The MLZ Series is a line of multilayer choke coils for decoupling power circuits.

The MLZ2012-W Series, a line of the MLZ Series, has increased its DC superimposition characteristics by up to 250%* compared with existing products through the use of TDK's proprietary ferrite material technology.

Also available is the MLZ2012-L Series. This series has lowered its resistance by up to 50% compared with existing products through the adoption of a new ferrite material and dense electrodes. This series includes the E6 Series, which handles 1.0 to 15 μ H, hence it is extremely useful in the power-supply design of low-voltage circuits.

FEATURES

- The W Series (IDC UP type) is a line of products that have achieved the industry's best* DC superimposition characteristics.
* According to research conducted in August 2010.
- The L Series (Low-resistance type) has lowered its resistance by up to 50% compared with existing products.
- The D Series (High frequency type) is a line of decoupling coil products for high frequencies. It can handle higher noise frequencies.
- With its wider inductance range (0.1 to 46 μ H) and the addition of the E6 Series, this series can satisfy a wide variety of requirements.

APPLICATIONS

Modules such as digital cellular phone and camera module, Netbooks, note PCs, DSCs, DVCs, video games, portable memory audio devices, navigation systems, PNDs, TVs, W-LANs, solid state drives

SPECIFICATIONS

Operating temperature range	-55 to +125°C [including its own temperature rise]
Storage temperature range	-55 to +125°C

RECOMMENDED SOLDERING CONDITION REFLOW SOLDERING

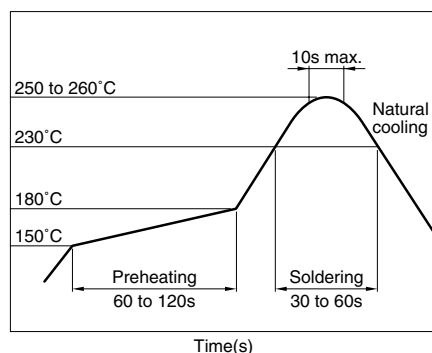

- Conformity to RoHS Directive: This means that, in conformity with EU Directive 2002/95/EC, lead, cadmium, mercury, hexavalent chromium, and specific bromine-based flame retardants, PBB and PBDE, have not been used, except for exempted applications.
- Please contact our Sales office when your application are considered the following:
The device's failure or malfunction may directly endanger human life (e.g. application for automobile/aircraft/medical/nuclear power devices, etc.)

All specifications are subject to change without notice.

PRODUCT IDENTIFICATION

MLZ	2012	A	1R0	W	T
(1)	(2)	(3)	(4)	(5)	(6)

(1) Series name

(2) Dimensions L×W

2012	2.0×1.25mm
------	------------

(3) Management symbol

(4) Inductance value

R10	0.1 μ H
1R0	1.0 μ H
100	10.0 μ H

(5) Types of characteristics

D	High frequency type
W	IDC-UP type
L	Low-resistance type

(6) Packaging style

T	Taping [reel]
---	---------------

PACKAGING STYLE AND QUANTITIES

Packaging style	Thickness T(mm)	Quantity
Taping	0.85	4000 pieces/reel
	1.25	2000 pieces/reel

HANDLING AND PRECAUTIONS

- Before soldering, be sure to preheat components.
The preheating temperature should be set so that the temperature difference between the solder temperature and product temperature does not exceed 150°C.
- After mounting components onto the printed circuit board, do not apply stress through board bending or mishandling.
- The inductance value may change due to magnetic saturation if the current exceeds the rated maximum.
- Do not expose the inductors to stray magnetic fields.
- Avoid static electricity discharge during handling.
- When hand soldering, apply the soldering iron to the printed circuit board only. Temperature of the iron tip should not exceed 350°C. Soldering time should not exceed 3 seconds.

SHAPES AND DIMENSIONS/RECOMMENDED PC BOARD PATTERN

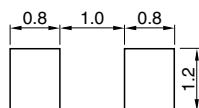
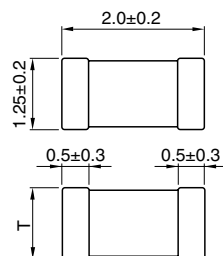

Dimensions in mm

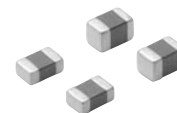

T(Thickness)	Weight(mg)
0.85±0.2	10
1.25±0.2	14

ELECTRICAL CHARACTERISTICS

Classification	Part No.	Inductance (μH)	Inductance tolerance	Thickness (mm)	Test frequency L (MHz)	Test current L (mA)	Self-resonant frequency (MHz)typ.	DC resistance (Ω)±30%	Rated current*1 (mA)	Rated current*2 (mA)
High frequency type	MLZ2012DR10DT	0.10	±20%	0.85	25	1.0	500	0.07	1000	1150
	MLZ2012DR22DT	0.22	±20%	0.85	25	1.0	330	0.13	800	900
	MLZ2012DR47DT	0.47	±20%	1.25	25	1.0	230	0.18	550	700
IDC-UP type	MLZ2012A1R0WT	1.00	±20%	0.85	10	1.0	160	0.10	280	900
	MLZ2012A1R5WT	1.50	±20%	0.85	10	1.0	140	0.13	250	750
	MLZ2012A2R2WT	2.20	±20%	0.85	10	1.0	120	0.15	210	650
	MLZ2012A3R3WT	3.30	±20%	0.85	10	1.0	90	0.34	200	450
	MLZ2012M4R7WT	4.70	±20%	0.85	2	0.1	70	0.30	180	500
	MLZ2012M6R8WT	6.80	±20%	1.25	2	0.1	60	0.40	160	400
	MLZ2012M100WT	10.0	±20%	1.25	2	0.1	50	0.47	150	350
	MLZ2012M150WT	15.0	±20%	1.25	2	0.1	40	0.95	120	250
	MLZ2012M220WT	22.0	±20%	1.25	2	0.1	35	2.00	60	220
	MLZ2012M330WT	33.0	±20%	1.25	2	0.1	28	2.60	55	190
Low-resistance type	MLZ2012M470WT	47.0	±20%	1.25	2	0.1	20	3.70	50	170
	MLZ2012N1R0LT	1.00	±20%	0.85	2	0.1	160	0.06	220	1150
	MLZ2012N1R5LT	1.50	±20%	0.85	2	0.1	140	0.10	190	900
	MLZ2012N2R2LT	2.20	±20%	0.85	2	0.1	120	0.12	170	800
	MLZ2012N3R3LT	3.30	±20%	0.85	2	0.1	90	0.15	130	750
	MLZ2012N4R7LT	4.70	±20%	0.85	2	0.1	70	0.18	130	600
	MLZ2012N6R8LT	6.80	±20%	0.85	2	0.1	60	0.25	110	550
	MLZ2012N100LT	10.0	±20%	1.25	2	0.1	50	0.30	110	500
	MLZ2012N150LT	15.0	±20%	1.25	2	0.1	40	0.47	90	350

*1 Current assumed when inductance has decreased by 50%.

*2 Current assumed when temperature has risen to 20°C (reference value). The maximum operating temperature at this time is 105°C.

• Test equipment

Inductance: Ag4294A-16034G

TYPICAL ELECTRICAL CHARACTERISTICS

INDUCTANCE vs. FREQUENCY CHARACTERISTICS

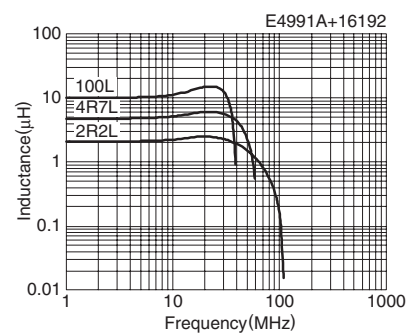
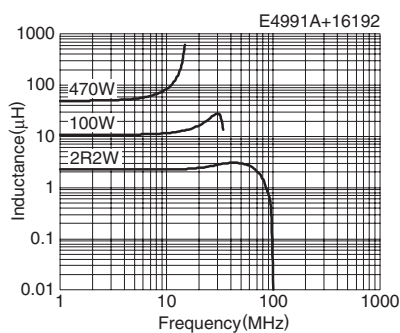
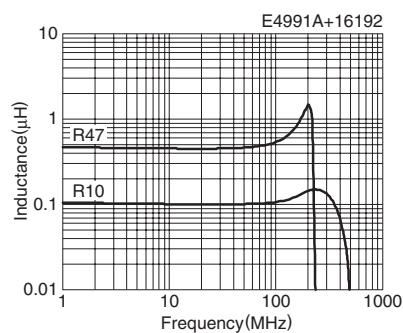

• All specifications are subject to change without notice.

TYPICAL ELECTRICAL CHARACTERISTICS

IMPEDANCE vs. FREQUENCY CHARACTERISTICS

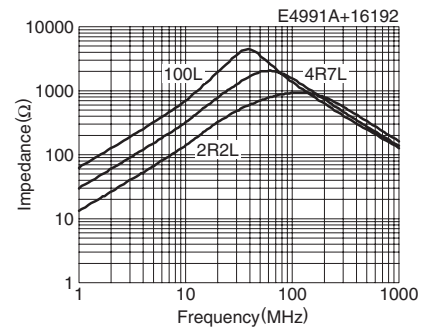
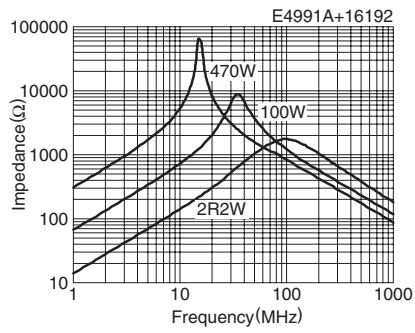
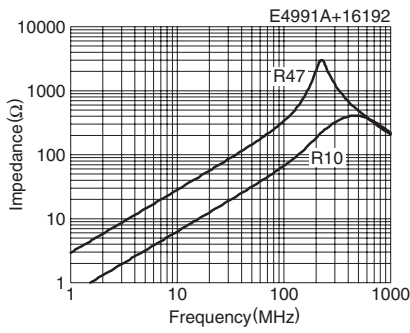

INDUCTANCE CHANGE vs. DC SUPERPOSITION CHARACTERISTICS

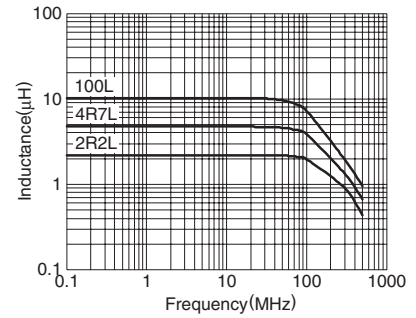
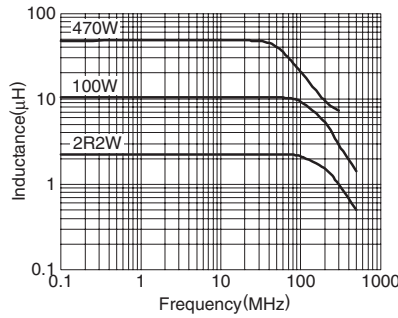
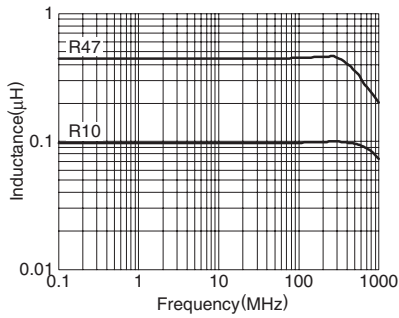

TEMPERATURE CHARACTERISTICS

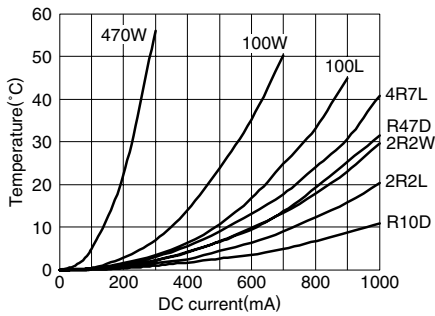

• All specifications are subject to change without notice.

PACKAGING STYLES REEL DIMENSIONS

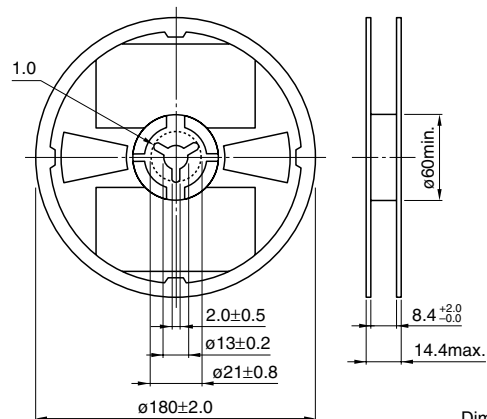

Dimensions in mm

TAPE DIMENSIONS

t=0.85mm

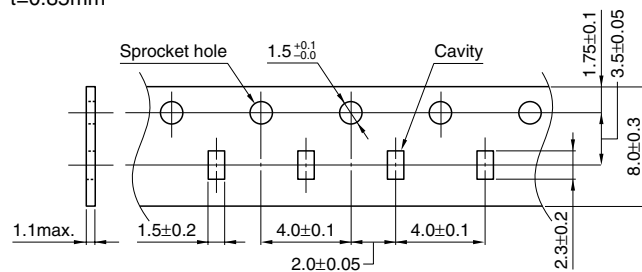

t=1.25mm

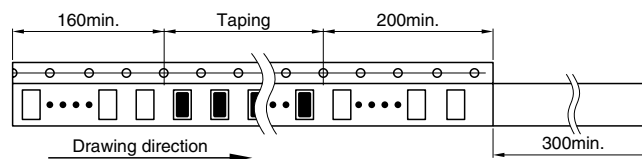
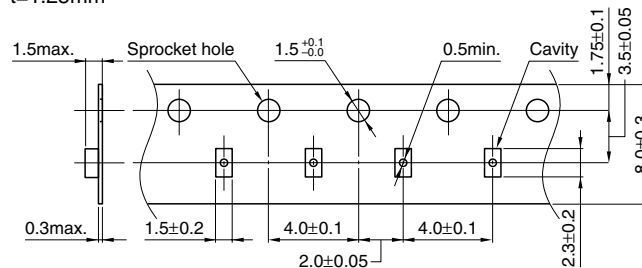

Dimensions in mm

• All specifications are subject to change without notice.