

SMD Inductors(Coils) For High Frequency(Multilayer)

Conformity to RoHS Directive

MLK Series MLK0603

FEATURES

- Inductance values are supported from 1 to 33nH.
- With the adoption of a giga-spiral laminated structure, self-resonant frequency higher than that of the MLG structure can be obtained, while the decrease of Q in the GHz band is limited.
- Advanced monolithic structure is formed using a multilayering and sintering process with ceramic and conductive materials for high-frequency.
- There is no directivity.
- The products contain no lead and also support lead-free soldering.
- It is a product conforming to RoHS directive.

APPLICATIONS

For high-frequency applications including mobile phones, high frequency modules (PA, VCO, FEM etc.), Bluetooth, W-LAN, UWB and tuners.

SHAPES AND DIMENSIONS/RECOMMENDED PC BOARD PATTERN

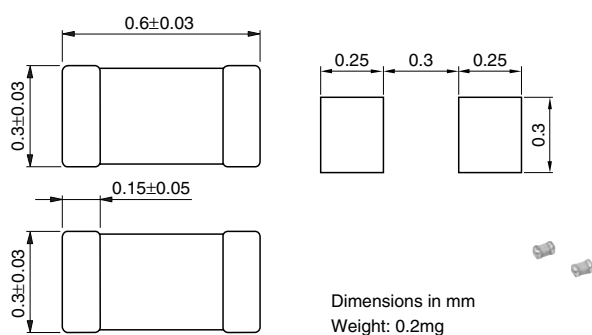

RECOMMENDED SOLDERING CONDITION REFLOW SOLDERING

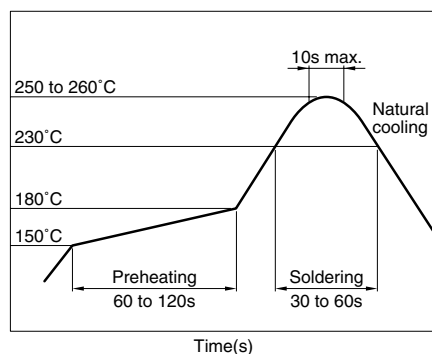

- Conformity to RoHS Directive: This means that, in conformity with EU Directive 2002/95/EC, lead, cadmium, mercury, hexavalent chromium, and specific bromine-based flame retardants, PBB and PBDE, have not been used, except for exempted applications.
- Please contact our Sales office when your application are considered the following:
The device's failure or malfunction may directly endanger human life (e.g. application for automobile/aircraft/medical/nuclear power devices, etc.)

• All specifications are subject to change without notice.

PRODUCT IDENTIFICATION

MLK 0603 L 10N J T
(1) (2) (3) (4) (5) (6)

(1) Series name

(2) Dimensions

0603	0.6×0.3mm (L×W)
------	-----------------

(3) Material code

(4) Inductance value

2N2	2.2nH
12N	12nH

(5) Inductance tolerance

S	±0.3nH
J	±5%

(6) Packaging style

T	Taping (reel)
---	---------------

SPECIFICATIONS

Operating temperature range	-55 to +125°C
Storage temperature range	-55 to +125°C

PACKAGING STYLE AND QUANTITIES

Packaging style	Quantity
Taping	15000 pieces/reel

HANDLING AND PRECAUTIONS

- Before soldering, be sure to preheat components.
The preheating temperature should be set so that the temperature difference between the solder temperature and product temperature does not exceed 150°C.
- After mounting components onto the printed circuit board, do not apply stress through board bending or mishandling.
- When hand soldering, apply the soldering iron to the printed circuit board only. Temperature of the iron tip should not exceed 350°C. Soldering time should not exceed 3 seconds.

ELECTRICAL CHARACTERISTICS

Inductance (nH)	Inductance tolerance	Test frequency L (MHz)	Q min.	Test frequency Q (MHz)	Self-resonant frequency (GHz)		DC resistance (Ω)		Rated current (mA)max.	Part No.
					min.	typ.	max.	typ.		
1.0	$\pm 0.3nH$	100	6	300	12.0	17.1	0.20	0.09	300	MLK0603L1N0ST
1.1	$\pm 0.3nH$	100	6	300	11.0	17.1	0.22	0.10	300	MLK0603L1N1ST
1.2	$\pm 0.3nH$	100	6	300	11.0	16.1	0.22	0.11	300	MLK0603L1N2ST
1.3	$\pm 0.3nH$	100	6	300	10.0	15.8	0.24	0.12	300	MLK0603L1N3ST
1.5	$\pm 0.3nH$	100	6	300	10.0	14.9	0.24	0.12	300	MLK0603L1N5ST
1.6	$\pm 0.3nH$	100	6	300	10.0	14.3	0.27	0.13	300	MLK0603L1N6ST
1.8	$\pm 0.3nH$	100	6	300	10.0	13.8	0.27	0.14	300	MLK0603L1N8ST
2.0	$\pm 0.3nH$	100	6	300	9.0	12.6	0.30	0.15	300	MLK0603L2N0ST
2.2	$\pm 0.3nH$	100	6	300	9.0	12.5	0.30	0.17	300	MLK0603L2N2ST
2.4	$\pm 0.3nH$	100	6	300	8.5	11.4	0.35	0.17	300	MLK0603L2N4ST
2.7	$\pm 0.3nH$	100	6	300	8.5	10.9	0.35	0.18	300	MLK0603L2N7ST
3.0	$\pm 0.3nH$	100	6	300	8.0	10.6	0.40	0.20	200	MLK0603L3N0ST
3.3	$\pm 0.3nH$	100	6	300	8.0	10.5	0.40	0.22	200	MLK0603L3N3ST
3.6	$\pm 0.3nH$	100	6	300	8.0	9.9	0.45	0.22	200	MLK0603L3N6ST
3.9	$\pm 0.3nH$	100	6	300	8.0	9.8	0.45	0.25	200	MLK0603L3N9ST
4.3	$\pm 0.3nH$	100	6	300	7.5	9.5	0.50	0.28	200	MLK0603L4N3ST
4.7	$\pm 0.3nH$	100	6	300	7.5	9.5	0.50	0.28	200	MLK0603L4N7ST
5.1	$\pm 0.3nH$	100	6	300	6.5	8.8	0.60	0.28	200	MLK0603L5N1ST
5.6	$\pm 0.3nH$	100	6	300	6.5	8.5	0.60	0.30	200	MLK0603L5N6ST
6.2	$\pm 0.3nH$	100	6	300	6.0	8.3	0.65	0.34	200	MLK0603L6N2ST
6.8	$\pm 5\%$	100	6	300	6.0	8.1	0.65	0.34	200	MLK0603L6N8JT
7.5	$\pm 5\%$	100	6	300	6.0	7.7	0.70	0.36	200	MLK0603L7N5JT
8.2	$\pm 5\%$	100	6	300	6.0	7.9	0.70	0.41	200	MLK0603L8N2JT
9.1	$\pm 5\%$	100	6	300	5.5	7.4	0.80	0.42	200	MLK0603L9N1JT
10	$\pm 5\%$	100	6	300	5.5	7.5	0.80	0.48	200	MLK0603L10NJT
12	$\pm 5\%$	100	6	300	5.0	6.9	1.00	0.54	150	MLK0603L12NJT
15	$\pm 5\%$	100	6	300	4.5	6.6	1.10	0.66	150	MLK0603L15NJT
18	$\pm 5\%$	100	6	300	4.0	5.8	1.30	0.85	100	MLK0603L18NJT
22	$\pm 5\%$	100	6	300	3.5	5.3	1.60	1.02	100	MLK0603L22NJT
27	$\pm 5\%$	100	6	300	3.0	4.6	1.70	1.09	100	MLK0603L27NJT
33	$\pm 5\%$	100	6	300	2.8	4.4	1.80	1.21	100	MLK0603L33NJT

- Test equipment

- Inductance Q : HP4291A+16197A, or equivalent

- SRF: HP8720C, or equivalent

- Rdc: YOKOGAWA TYPE7561, or equivalent

L, Q vs. FREQUENCY CHARACTERISTICS

Part No.	Inductance(nH)typ.					Q typ.				
	500MHz	800MHz	1.8GHz	2.0GHz	2.4GHz	500MHz	800MHz	1.8GHz	2.0GHz	2.4GHz
MLK0603L1N0ST	0.9	0.9	0.9	0.9	0.9	10	12	19	20	22
MLK0603L1N1ST	1.0	1.0	0.9	0.9	0.9	9	11	17	18	20
MLK0603L1N2ST	1.1	1.0	1.0	1.0	1.0	9	12	18	19	21
MLK0603L1N3ST	1.2	1.1	1.1	1.1	1.1	9	12	18	19	21
MLK0603L1N5ST	1.3	1.3	1.3	1.3	1.3	9	12	18	19	21
MLK0603L1N6ST	1.4	1.4	1.4	1.4	1.4	9	12	18	19	21
MLK0603L1N8ST	1.6	1.6	1.6	1.6	1.6	9	11	17	18	20
MLK0603L2N0ST	1.8	1.7	1.7	1.7	1.7	9	12	17	18	20
MLK0603L2N2ST	2.0	1.9	1.9	1.9	2.0	10	12	19	20	22
MLK0603L2N4ST	2.1	2.1	2.1	2.1	2.1	9	12	18	19	20
MLK0603L2N7ST	2.4	2.4	2.4	2.4	2.4	10	13	19	20	22
MLK0603L3N0ST	2.7	2.6	2.6	2.6	2.7	9	12	18	19	21
MLK0603L3N3ST	3.0	2.9	2.9	3.0	3.0	10	13	19	20	22
MLK0603L3N6ST	3.2	3.1	3.1	3.1	3.2	9	11	17	18	19
MLK0603L3N9ST	3.5	3.4	3.5	3.5	3.5	10	13	19	20	22
MLK0603L4N3ST	3.8	3.8	3.8	3.8	3.9	10	12	18	19	20
MLK0603L4N7ST	4.2	4.2	4.2	4.2	4.3	10	13	19	20	22
MLK0603L5N1ST	4.6	4.5	4.5	4.6	4.7	10	12	18	19	21
MLK0603L5N6ST	5.0	5.0	5.0	5.0	5.1	10	12	18	19	21
MLK0603L6N2ST	5.5	5.5	5.5	5.6	5.7	10	12	18	19	20
MLK0603L6N8JT	6.2	6.1	6.2	6.2	6.4	10	13	19	20	22
MLK0603L7N5JT	6.7	6.6	6.7	6.8	7.0	10	12	18	19	20
MLK0603L8N2JT	7.4	7.3	7.5	7.6	7.8	10	13	19	20	21
MLK0603L9N1JT	8.2	8.1	8.3	8.4	8.6	10	12	18	18	20
MLK0603L10NJT	9.0	8.9	9.2	9.3	9.6	10	13	18	19	20
MLK0603L12NJT	10.8	10.6	11.0	11.2	11.6	10	12	18	18	20
MLK0603L15NJT	13.5	13.4	13.9	14.2	14.8	10	12	17	18	19
MLK0603L18NJT	16.2	16.1	17.0	17.4	18.4	10	12	16	17	18
MLK0603L22NJT	19.8	19.7	20.9	21.5	22.8	10	12	16	16	17
MLK0603L27NJT	24.4	24.4	27.2	28.6	31.7	10	12	15	15	14
MLK0603L33NJT	29.7	29.7	33.4	35.1	39.3	9	11	14	14	13

- All specifications are subject to change without notice.

TYPICAL ELECTRICAL CHARACTERISTICS INDUCTANCE vs. FREQUENCY CHARACTERISTICS

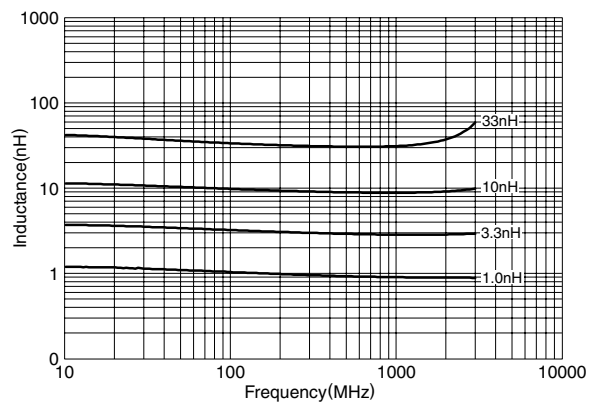

Q vs. FREQUENCY CHARACTERISTICS

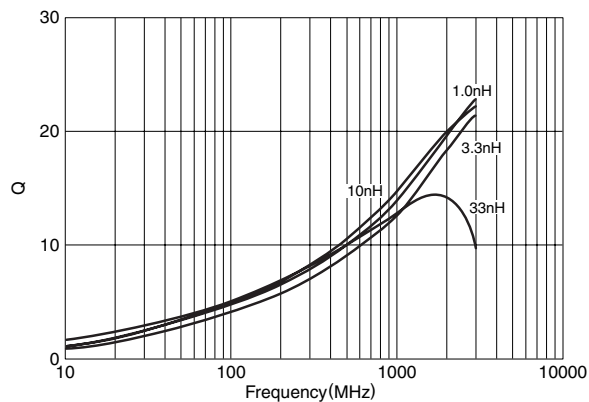

PACKAGING STYLES REEL DIMENSIONS

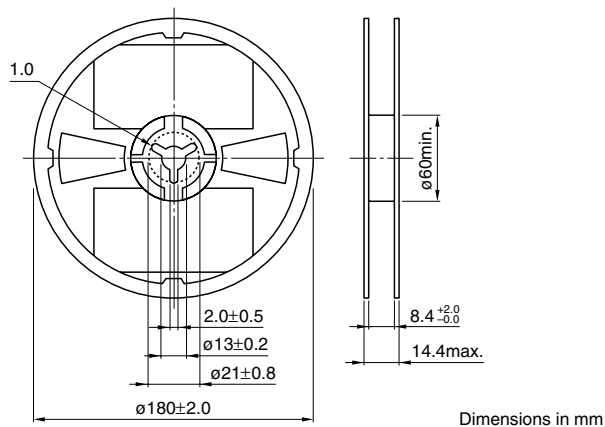

TAPE DIMENSIONS

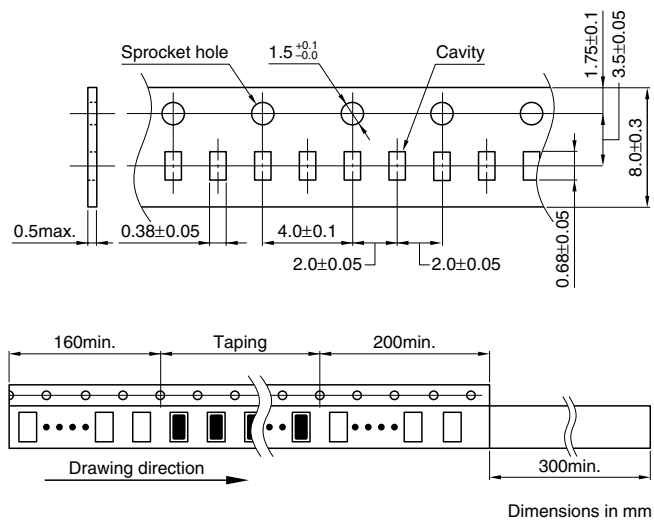

• All specifications are subject to change without notice.