

10 9 8 7 6 5 4 3 2 1

F

E

D

C

B

A

F

E

D

C

B

A

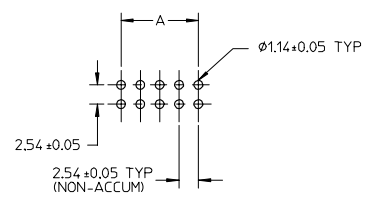
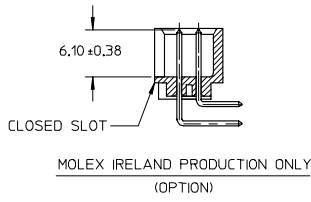
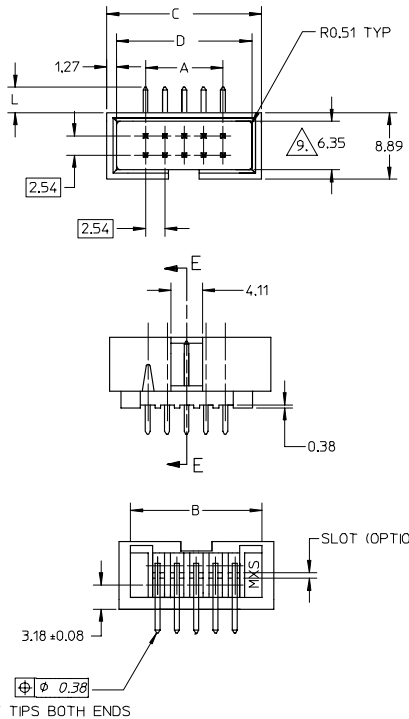

RECOMMENDED PCB HOLE LAYOUT

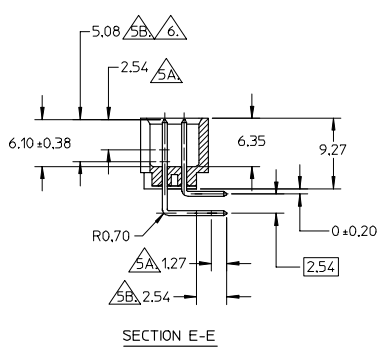

SECTION E-E

LEGEND:
A-70246 - * * * *
CKT SIZE
PLATING OPT.
SEE TABLE FOR DETAIL

ADD NOTE AND SYM 9. EC NO. S2005-0641 DRAWN BY 2005/02/28 CHECKED BY 2005/02/28 CHKD:PTLM APPR:SKTJH 2005/03/02	QUALITY SYMBOLS ▽=0 ▽=0	GENERAL TOLERANCES (UNLESS SPECIFIED)		DIMENSION STYLE MM ONLY		SCALE NTS	DESIGN UNITS METRIC	THIRD ANGLE PROJECTION	
		mm	INCH	DRAWN BY	DATE	TITLE SALES DRAWING, C-GRID SHROUDED HEADER, R/A (SLOTTED W/O STANDOFFS)			
		4 PLACES ± ---	± ---	JENNIFER	1987/09/21	MOLEX INCORPORATED			
		3 PLACES ± ---	± ---	CHECKED BY	DATE	MATERIAL NO. SEE TABLE DOCUMENT NO. SDA-70247-**00-04 SHEET NO. 1 OF 2			
2 PLACES ± 0.20	± ---	MLA	1987/09/21	DRAFT WHERE APPLICABLE MUST REMAIN WITHIN DIMENSIONS					
1 PLACE ± ---	± ---	APPROVED BY	DATE	SIZE A3 THIS DRAWING CONTAINS INFORMATION THAT IS PROPRIETARY TO MOLEX INCORPORATED AND SHOULD NOT BE USED WITHOUT WRITTEN PERMISSION					
		ALANB	1987/09/21						

9 8 7 6 5 4 3 2 1

10 9 8 7 6 5 4 3 2 1

NOTES:

1. PIN PUSHOUT FORCE (.9072KG)/2LBS MIN.
2. PIN SOLDERABILITY PER MOLEX SPEC. ES-152.
3. PRODUCT SPEC: PS-70246 APPLIES.
4. WAFER TO BE FLAT WITHIN .003 MM/MM.
5. DIMENSIONS FOR PLATING LOCATION:

 MEASURE POINT FOR THICKNESS

 MINIMUM COVERAGE

 GOLD END OF PIN UNLESS OVERALL PLATED.

-  FINISH: - 571 : 15 MICRO INCHES MIN GOLD PLATE ON CONTACT AND 75 MICRO INCHES MIN TIN PLATE ON SOLDER TAIL BOTH OVER 50 MICRO INCHES MIN NICKEL OVERALL.
- 571A: 15 MICRO INCHES MIN GOLD PLATE ON CONTACT AND 75 MICRO INCHES MIN TIN/LEAD PLATE ON SOLDER TAIL BOTH OVER 50 MICRO INCHES MIN NICKEL OVERALL.
- 574 : 15 MICRO INCHES MIN GOLD PLATE ON CONTACT AND 75 MICRO INCHES MIN TIN PLATE ON SOLDER TAIL BOTH OVER 50 MICRO INCHES MIN NICKEL OVERALL.
- 574A: 15 MICRO INCHES MIN GOLD PLATE ON CONTACT AND 75 MICRO INCHES MIN TIN/LEAD PLATE ON SOLDER TAIL BOTH OVER 50 MICRO INCHES MIN NICKEL OVERALL.



 CHECK WITH SALES OFFICE FOR AVAILABILITY.

 DIM AT THE CENTRE OF THE SHROUDED WALL SHALL BE 5.9MM MIN. THIS SPEC IS VALID FOR ALL CKT SIZE.

10. MATERIAL:
 HSG: 15% GF. PBT, 94V-0, COLOUR BLACK
 (SPEC NO: 89992-0028)
 PIN: 0.64MM SQ. PIN PHOSPHOR BRONZE.

PART NUMBER 	CKT SIZE	DIM A	DIM B	DIM C	DIM D
70247-08**	08	7.62	14.73	17.78	15.24
70247-10**	10	10.16	17.27	20.32	17.78
70247-12**	12	12.70	19.81	22.86	20.32
70247-14**	14	15.24	22.35	25.40	22.86
70247-16**	16	17.78	24.89	27.94	25.40
70247-20**	20	22.86	29.97	33.02	30.48
70247-24**	24	27.94	35.05	38.10	35.56
70247-26**	26	30.48	37.59	40.64	38.10
70247-30**	30	35.56	42.67	45.72	43.18
70247-34**	34	40.64	47.75	50.80	48.26
70247-40**	40	48.26	55.37	58.42	55.88
70247-44**	44	53.34	60.45	63.50	60.96
70247-48**	48	58.42	65.53	68.58	66.04
70247-50**	50	60.96	68.07	71.12	68.58
70247-56**	56	68.58	75.69	78.74	76.20
70247-60**	60	73.66	80.77	83.82	81.28
70247-64**	64	78.74	85.85	88.90	86.36
70247-72**	72	88.90	96.01	99.06	96.52

 PART NUMBER		L	L1
TIN	TIN/LEAD		
70247-**74	70247-**34	3.05	0
70247-**50	70247-**00		
70247-**51	70247-**01		
70247-**52	70247-**02		
70247-**53	70247-**03		
70247-**54	70247-**04		

ADD NOTE AND SYM 9. EC NO. S2005-0641 DRAWN/SEE 2005/02/28 CHKD/PTLM 2005/02/28 APPR/SKUH 2005/03/03	QUALITY SYMBOLS	GENERAL TOLERANCES (UNLESS SPECIFIED)	DIMENSION STYLE MM ONLY	SCALE NTS	DESIGN UNITS METRIC	THIRD ANGLE PROJECTION	
	$\nabla=0$ $\nabla=0$	mm INCH 4 PLACES ± --- ± --- 3 PLACES ± --- ± --- 2 PLACES ± 0.20 ± --- 1 PLACE ± --- ± --- ANGULAR ± 3 °	DRAWN BY JENNIFER DATE 1987/09/21 CHECKED BY DATE APPROVED BY DATE ALANB 1987/09/21	TITLE			SALES DRAWING, C-GRID SHROUDED HEADER, R/A (SLOTTED W/O STANDOFFS)  MOLEX INCORPORATED
	DRAFT WHERE APPLICABLE MUST REMAIN WITHIN DIMENSIONS	MATERIAL NO.	DOCUMENT NO.	SHEET NO.			
	SEE TABLE	SDA-70247-**00-04	2 OF 2				
SIZE  THIS DRAWING CONTAINS INFORMATION THAT IS PROPRIETARY TO MOLEX INCORPORATED AND SHOULD NOT BE USED WITHOUT WRITTEN PERMISSION							

9 8 7 6 5 4 3 2 1