

10 9 8 7 6 5 4 3 2 1

F

E

D

C

B

A

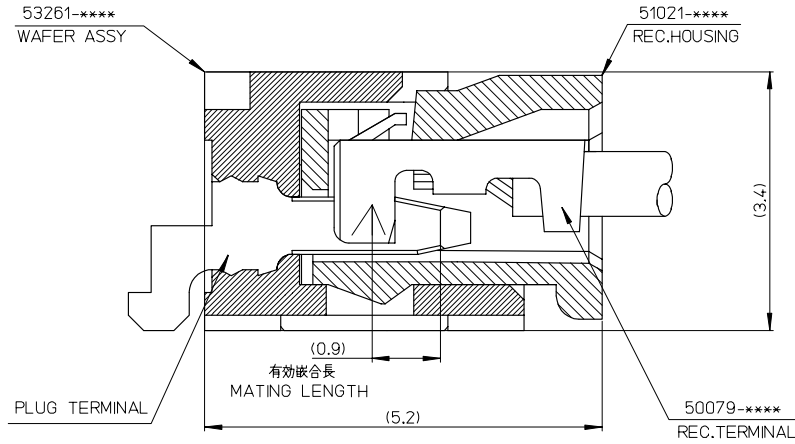

53261-****	WAFER ASSY	MODEL NO./MATERIAL NO.
50079-****	TERMINAL	
51021-****	HOUSING	

RELEASED EC NO: J2006-2426 DRWN: YAOYAGI CHKD: YMAEDA APPR: NUKITA	GENERAL TOLERANCES (UNLESS SPECIFIED)	DIMENSION STYLE MM ONLY	SCALE ---	DESIGN UNITS METRIC	THIRD ANGLE PROJECTION
	10 UNDER ±---	DRAWN BY Y. AOYAGI	DATE 2006/01/30	TITLE 1.25 W-T-O-B CONN. 51021,53261 MATING CROSS SECTION	
	10 OVER 30 UNDER ±---	CHECKED BY Y. MAEDA	DATE 2006/01/30	MOLEX INCORPORATED	
	30 OVER ±---	APPROVED BY N. UKITA	DATE 2006/01/30	MATERIAL NO.	DOCUMENT NO. SD-51021-002
	ANGULAR ±--- °	DRAFT WHERE APPLICABLE MUST REMAIN WITHIN DIMENSIONS		SEE CHART	SHEET NO. 1 OF 1

tb_frame_A3_1_ME_S
Rev. D 2004/04/02

9 8 7 6 5 4 3 2 1 EN-02JA(021)

10 9 8 7 6 5 4 3 2 1

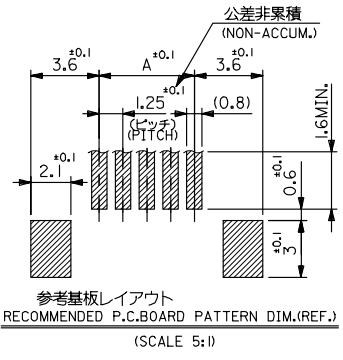
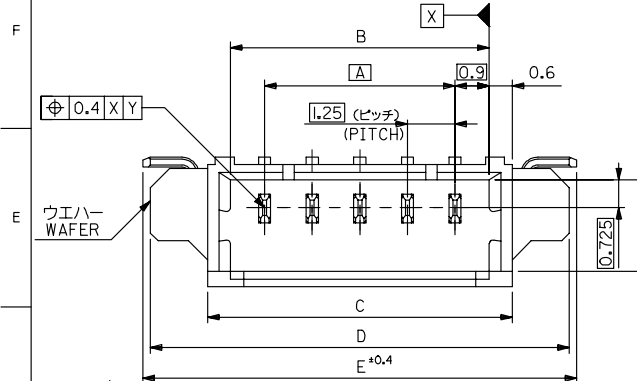

- 注記 NOTES
1. 嵌合相手: 51021シリーズ
MATES WITH: 51021 SERIES
 2. 材質 MATERIAL
ウエハー: NYLON46, UL94V-0
ピン: リン青銅, 半田メッキ
PIN: PHOS-BRO., Sn-Pb(9:1) 3 μmMIN.
OVER Cu 1 μmMIN.
PLATING
金具: リン青銅, 半田メッキ
FITTING NAIL: PHOS-BRO., Sn-Pb(9:1) 2 μmMIN.
OVER Cu 1 μmMIN.
PLATING
 - △ ロック窓は2、3極は1箇所、4極以上は2箇所とする。
LOCKING WINDOW: ONE PLACE FOR 2 AND 3 CKT. AND TWO PLACES FOR MORE THAN 3 CKT.
 4. ソルダータール部のスレ量及び金具(補強板)のスレ量は基準面[W]に対し、上方向0.05 MAX.、下方向に0.1 MAX.とする。
OFFSET BETWEEN BASIS PLANE [W] TO SOLDER TAIL BOTTOM: UPPER SIDE: 0.05MAX. LOWER SIDE: 0.1MAX.

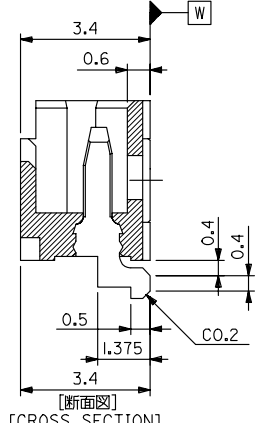
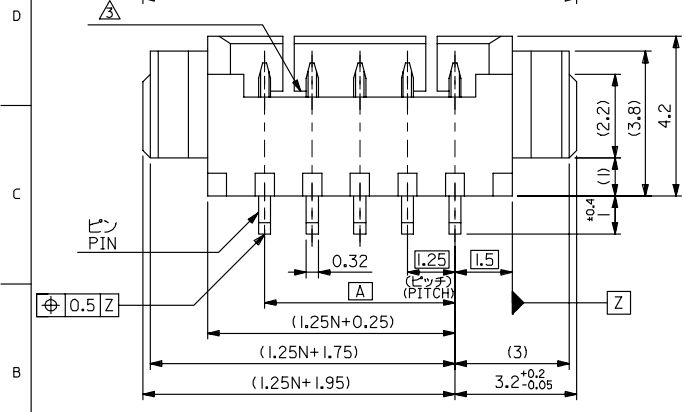

23.9	23.5	20.5	19.3	17.5	53261-1510	15
22.65	22.25	19.25	18.05	16.25	-1410	14
21.4	21	18	16.8	15	-1310	13
20.15	19.75	16.75	15.55	13.75	-1210	12
18.9	18.5	15.5	14.3	12.5	-1110	11
17.65	17.25	14.25	13.05	11.25	-1010	10
16.4	16	13	11.8	10	-0910	9
15.15	14.75	11.75	10.55	8.75	-0810	8
13.9	13.5	10.5	9.3	7.5	-0710	7
12.65	12.25	9.25	8.05	6.25	-0610	6
11.4	11	8	6.8	5	-0510	5
10.15	9.75	6.75	5.55	3.75	-0410	4
8.9	8.5	5.5	4.3	2.5	-0310	3
7.65	7.25	4.25	3.05	1.25	53261-0210	2
E	D	C	B	A	ENG. NO.	極数 CKT.

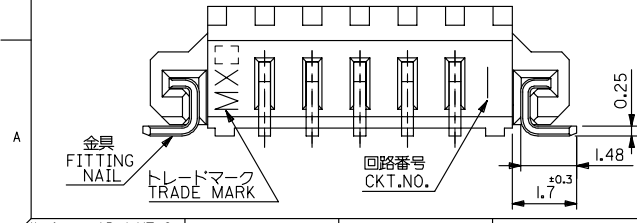

REVISED IEC NO. J2005-1631 2004/12/02 DRW: NESUZUKI CHK: KATOYODA APPR: NIKITA 2004/12/07	GENERAL TOLERANCES (UNLESS SPECIFIED)		DIMENSION STYLE MM ONLY		SCALE 10:1	DESIGN UNITS METRIC	THIRD ANGLE PROJECTION
	10 UNDER	±0.2	DRAWN BY HSEK INE	DATE 89/10/18	TITLE 1.25 WIRE TO BOARD WAFER ASS FOR SMT RIGHT ANGLE		
	10 OVER 30 UNDER	±0.25	CHECKED BY HHIRAMOT	DATE 94/06/23	MATERIAL NO. MOLEX INCORPORATED		
	30 OVER	±0.3	APPROVED BY MFUKUSHI	DATE 94/06/23	DOCUMENT NO. SD-53261-**10		
ANGULAR ±3°		DRAFT WHERE APPLICABLE MUST REMAIN WITHIN DIMENSIONS		SEE DRAWING		SHEET NO. 1 OF 1	
THIS DRAWING CONTAINS INFORMATION THAT IS PROPRIETARY TO MOLEX INCORPORATED AND SHOULD NOT BE USED WITHOUT WRITTEN PERMISSION				EN-02JAI(021)			

DWG. NO. SD-53261-090

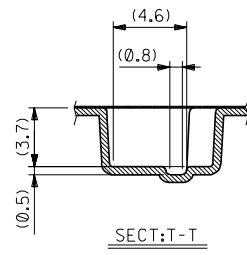
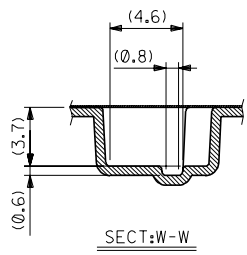
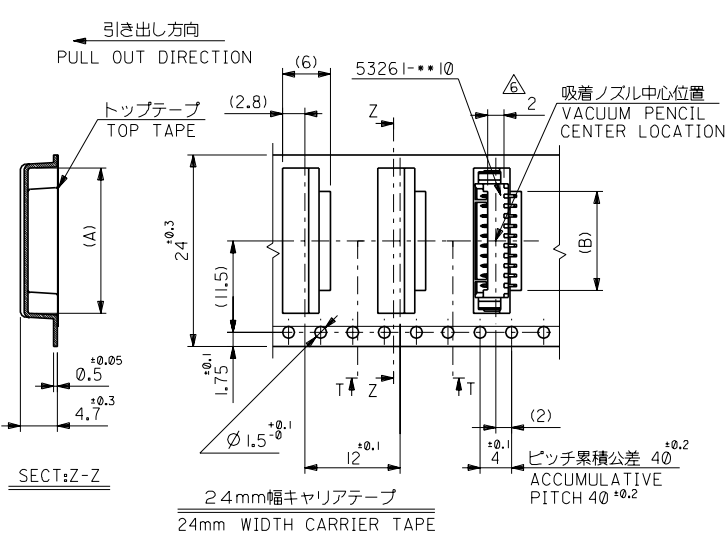
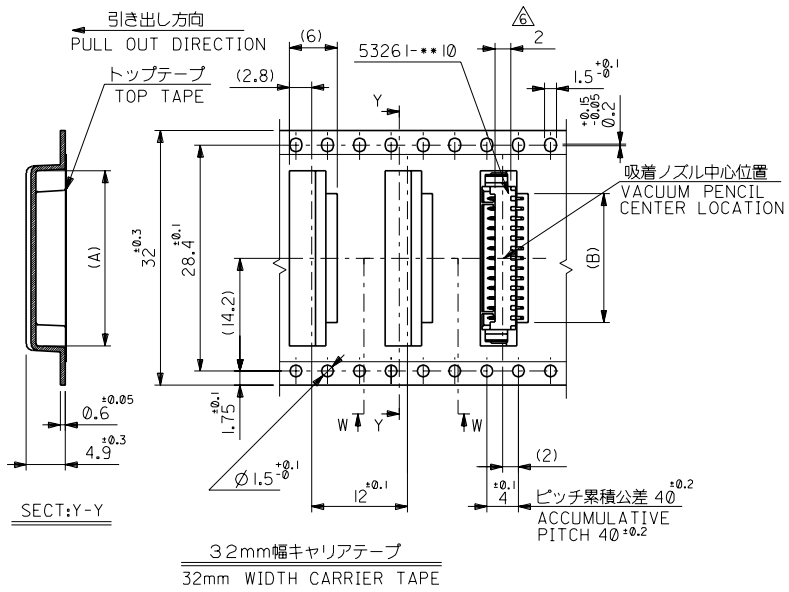

32	32.4	16.2	22	53261-1390	13	
		14.95	20.75	-1290	12	
24	24.4	13.7	19.5	-1190	11	
		12.45	18.25	-1090	10	
		11.2	17	-0990	9	
		9.95	15.75	-0890	8	
		8.7	14.5	-0790	7	
		7.45	13.25	-0690	6	
		6.2	12	-0590	5	
4.95	10.75	53261-0490	4			
キャリアテープ幅 CARRIER TAPE WIDTH		C	B	A	ENG. NO.	種数 CKT.

材料 MATERIAL		注記参照 SEE NOTES		molex MOLEX-JAPAN CO.,LTD. 日本モレックス株式会社	
仕上げ FINISH		—		REVISE ONLY ON CAD SYSTEM	
適用電線範囲 WIRE RANGE		—		TITLE 名称 1.25 WIRE TO BOARD CONN. WAFER ASS'Y FOR SMT. EMBOSSED TAPE PACKAGE	
被覆外径 INS. RANGE		—		DWG. NO. SHEET 2 OF 3 REV SD-53261-090 F	
角度 ANGLE	±3°	記号 LTR	変更内容 REVISION RECORD	DR. DATE	尺度 SCALE
30°以上 OVER	±0.3	F	変更 REVISED (02/28/00)	S.M. T.Y.	00/12/8
10°以上 未過 OVER 30 UNDER	±0.25	E	変更及/再作図 REVISED/REDRAWN (J30522)	K.T. H.H.	93/6/1
10°以下 UNDER	±0.2				
一般公差 GENERAL TOLERANCES					

THIS DRAWING CONTAINS INFORMATION THAT IS PROPRIETARY TO MOLEX/JAPAN AND SHOULD NOT BE USED WITHOUT WRITTEN PERMISSION
 本図面は日本モレックス(株)の所有する情報を含むもので、当社の許可なく複製を禁止する。 EN-01C(032)MXJ-32

8 7 6 5 4 3 2 1

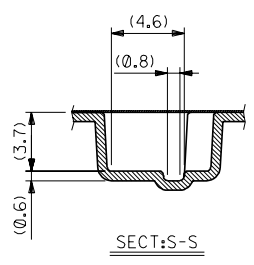
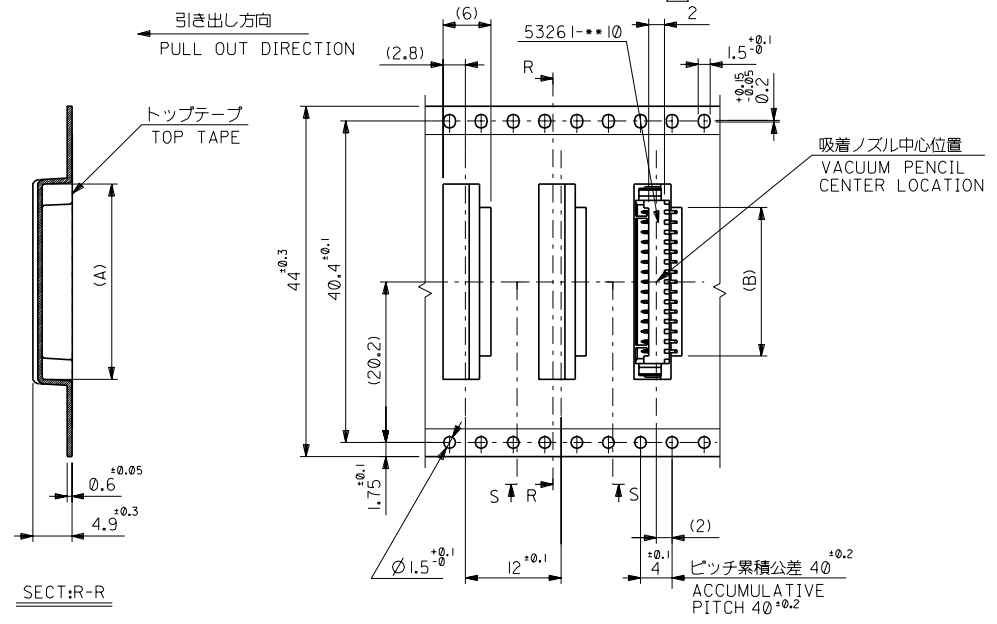

44mm幅キャリアテープ
44mm WIDTH CARRIER TAPE

44	44.4	18.7	24.5	53261-1590	15
キャリアテープ幅 CARRIER TAPE WIDTH	C	B	A	ENG. NO.	極数 CKT.
		17.45	23.25	53261-1490	14

材料 MATERIAL	注記参照 SEE NOTES		MOLEX-JAPAN CO.,LTD. 日本モレックス株式会社		
仕上げ FINISH	—		REVISE ONLY ON CAD SYSTEM		
適用電線範囲 WIRE RANGE	—		TITLE 名称 1.25 WIRE TO BOARD CONN. WAFER ASS'Y FOR SMT. EMBOSSED TAPE PACKAGE		
被覆外径 INS. RANGE	—		DRAWN BY '93/6/1 K.TOJO CHK'D BY '00/12/8 T.YAMAGUCHI		
角度 ANGLE	±3°		DWG. NO. SHEET 3 OF 3 REV SD-53261-90 F		
30°以上 OVER	±0.3				
10°以上 30°未満 OVER 30 UNDER	±0.25	F	変更 REVISED	UC2001-04371	S.M.T. 00/12/8
10°未満 UNDER	±0.2	E	変更及び再作図 REVISED&RE-DRAWN	U305221	K.T.H.H. 93/6/1
一般公差 GENERAL TOLERANCES			記号 LTR	変更内容 REVISION RECORD	DR / CHK / DATE

THIS DRAWING CONTAINS INFORMATION THAT IS PROPRIETARY TO MOLEX/JAPAN AND SHOULD NOT BE USED WITHOUT WRITTEN PERMISSION
本図面は日本モレックス(株)の所有する情報を含むもので、当社の許可なく複製を禁止する。
EN-01C(032)MXJ-32

8 7 6 5 4 3 2 1