

PRODUCT NUMBER  
98401-XXX-XXLF

WHEN REQUIRED, ADD SUFFIX LETTER "LF"  
INDICATES THE PRODUCT IS RoHS  
COMPATIBLE, SEE NOTE 7

TOTAL NB OF POSITIONS, 8 TO 50

PACKAGING TYPE, NOTE 3

PLATING

- 1=0.76µm GOLD/GXT ON CONTACT AREA  
3.81µm TIN-LEAD ON TAIL
- 4=3.81µm TIN-LEAD ON CONTACT AREA  
AND ON TAIL
- 8=0.38µm GOLD/GXT ON CONTACT AREA  
3.81µm TIN-LEAD ON TAIL

PIN STYLE	MATING	OAH
01	5.84	10.2
02	8.08	12.4
03	13.00	17.4
06	10.50	14.85
07	14.50	18.90

WHEN "LF" IS REQUIRED, 2µm MIN  
MATTE TIN OVER 1.27µm MIN NICKEL  
INSTEAD OF TIN-LEAD

NOTES:

1. HOUSING MAT'L : HIGH TEMPERATURE  
THERMOPLASTIC. UL94V-0 COLOR: BLACK
2. PIN MATERIAL : PHOSPHOR BRONZE
3. PACKAGING  
- = POLY BAGS  
A = TAPE & REEL + CAP (SEE TA840 FOR  
PRODUCT AVAILABILITY )
4. 9N MIN RETENTION IN EITHER DIRECTION
5. TO DETERMINE DIMENSIONS :  
N = NUMBER OF POSITIONS PER ROW  
EXAMPLE : 8 POS N x 2.54 = 20.32mm
6. HOLE DIMENSION TO BE  $\phi 1.6 \pm 0.03$  FOR  
INTERFERENCE FIT APPLICATIONS.  
HOLE DIMENSIONS TO BE  $\phi 1.95 \pm 0.05$  FOR  
LOCATION APPLICATION WITH AUTOMATIC  
PICK AND PLACE MACHINES.
7. RoHS COMPATIBLE PRODUCT SPECIFICATIONS
  - a - PLATING:  
- "LF" MEANS THE PRODUCT IS LEAD-FREE,  
2µm MINIMUM MATTE TIN OVER 1.27µm  
MINIMUM NICKEL UNDERPLATE.
  - b - MANUFACTURING PROCESS COMPATIBILITY  
- THE HOUSING WILL WITHSTAND EXPOSURE TO  
260°C PEAK TEMPERATURE FOR 30 SECONDES  
IN A CONVECTION, INFRA-RED OR VAPOR  
PHASE REFLOW OVEN.
  - c - LABELING:  
- MEETS PACKAGING SPECS AS PER GS-14-920
  - d - LEGAL STATEMENT: SEE GS-22-008

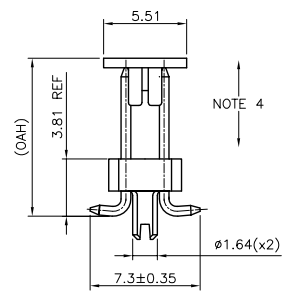
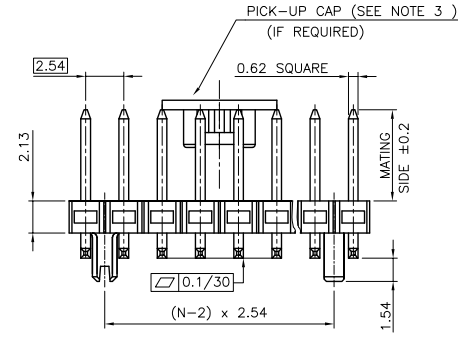
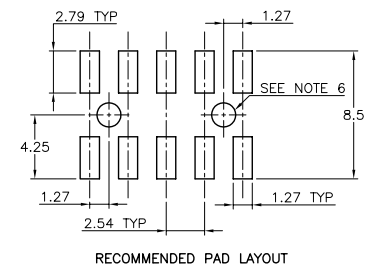
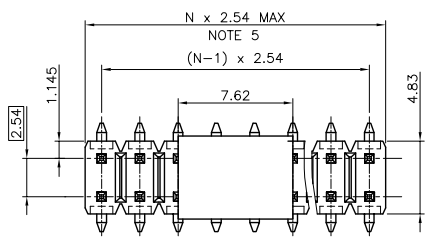

mat'l. code SEE NOTES		surface ISO 1302	tolerance ISO 406 ISO 1101	projection	product family BERGSTIK
Ltr	ecm no	dr	date	tolerances unless otherwise specified	title
H	F08-0148	JCO	08.05.19	angles	UNSHR.HEADER DR SMT
J	F11-0031	LMU	11.03.24	linear	
				x.xx ±0.3 x.xxx ±0.13 x.xxx ±0.05	
D	F04-0362	LMU	04.12.13	dr	D.LE
E	F06-0208	JCO	06.06.22	enrg	JM.C
F	F08-0155	JCO	08.04.05	chr	JM.C
G	F08-0170	LMU	08.05.16	appd	JF.N
sheet index	revision sheet				

FCJ  
dwg no 98401 sheet 1 of 1 size A3  
type CUSTOMER Drawing