

THIS DRAWING IS UNPUBLISHED
 ALL RIGHTS RESERVED

| REV | DATE | DESCRIPTION | BY | CHK | APP |
|-----|---------------------------|-------------|---------|-----|-----|
| G | EC 023C D124 05 | | 19M/R/S | BSV | JLG |
| G1 | REVISED PER ECO-09-020935 | | 28M/G/9 | KK | AEG |

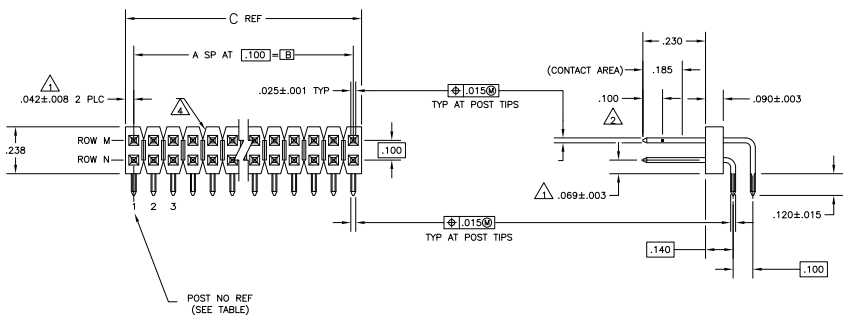

- △ THE NOTED DIMENSIONS APPLY AT THE INTERSECTION OF THE POST AND THE HOUSING
- △ POINT OF MEASUREMENT FOR PLATING THICKNESS
- 3. FOR ACTIVE POSITION SIZES 4 AND ABOVE, POSTS WILL BE SELECTIVELY SWAGED TO PROVIDE CONNECTOR RETENTION TO THE PC BOARD UNTIL SOLDERED. FOR POSITION SIZE 2, POSTS WILL BE KINKED (SEE TABLE FOR RETENTION FEATURE LOCATION)
- △ BREAKAWAY NOTCH ANGLE CAN BE ORIENTED TO THE RIGHT (AS SHOWN) OR TO THE LEFT
- △ POSTS: .000015 GOLD ON CONTACT AREA, .000100-.000200 MATTE TIN-LEAD ON THE SOLDER TAIL, ALL OVER .000500 NICKEL
- △ POSTS: .000015 GOLD ON CONTACT AREA, .000100-.000200 MATTE TIN ON THE SOLDER TAIL, ALL OVER .000500 NICKEL
- △ HIGH TEMPERATURE CONFIGURATION
- △ OBSOLETE PARTS: OBSOLETE CIS STREAMLINING PER D.RENAUD/D.SINISI

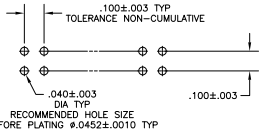

RECOMMENDED HOLE LAYOUT

| REMARKS | PLATING | ROW N | ROW M | C | B | A | NO OF POSN | ASSEMBLY PART NUMBER |
|------------|---------|-----------|-----------|-------|-------|----|------------|----------------------|
| △ OBSOLETE | | 1,2,39,40 | 1,2,39,40 | 3.984 | 3.900 | 39 | 80 | 7-104354-0 |
| △ OBSOLETE | | 1,2,29,30 | 1,2,29,30 | 2.984 | 2.900 | 29 | 60 | 6-104354-9 |
| △ OBSOLETE | | 1,2,24,25 | 1,2,24,25 | 2.484 | 2.400 | 24 | 50 | 5-104354-8 |
| △ OBSOLETE | | 1,2,19,20 | 1,2,19,20 | 1.984 | 1.900 | 19 | 40 | 6-104354-7 |
| △ OBSOLETE | | 1,2,16,17 | 1,2,16,17 | 1.684 | 1.600 | 16 | 34 | 6-104354-6 |
| △ OBSOLETE | | 1,2,14,15 | 1,2,14,15 | 1.484 | 1.400 | 14 | 30 | 6-104354-5 |
| △ OBSOLETE | | 1,2,13,14 | 1,2,13,14 | 1.384 | 1.300 | 13 | 28 | 6-104354-4 |
| △ OBSOLETE | | 1,2,12,13 | 1,2,12,13 | 1.284 | 1.200 | 12 | 26 | 6-104354-3 |
| △ OBSOLETE | | 1,2,11,12 | 1,2,11,12 | 1.184 | 1.100 | 11 | 24 | 6-104354-2 |
| △ OBSOLETE | | 1,2,10,11 | 1,2,10,11 | 1.084 | 1.000 | 10 | 22 | 6-104354-1 |
| △ OBSOLETE | | 1,2,9,10 | 1,2,9,10 | .984 | .900 | 9 | 20 | 6-104354-0 |
| △ OBSOLETE | | 1,2,8,9 | 1,2,8,9 | .884 | .800 | 8 | 18 | 5-104354-9 |
| △ OBSOLETE | | 1,2,7,8 | 1,2,7,8 | .784 | .700 | 7 | 16 | 5-104354-8 |
| △ OBSOLETE | | 1,2,6,7 | 1,2,6,7 | .684 | .600 | 6 | 14 | 5-104354-7 |
| △ OBSOLETE | | 1,2,5,6 | 1,2,5,6 | .584 | .500 | 5 | 12 | 5-104354-6 |
| △ OBSOLETE | | 1,2,4,5 | 1,2,4,5 | .484 | .400 | 4 | 10 | 5-104354-5 |
| △ OBSOLETE | | 1,2,3,4 | 1,2,3,4 | .384 | .300 | 3 | 8 | 5-104354-4 |
| △ OBSOLETE | | 1,2,3 | 1,2,3 | .284 | .200 | 2 | 6 | 5-104354-3 |
| △ OBSOLETE | | 1,2 | 1,2 | .184 | .100 | 1 | 4 | 5-104354-2 |
| △ OBSOLETE | | 1 | 1 | .084 | - | - | 2 | 104354-1 |

THIS DRAWING IS A CONTROLLED DOCUMENT. DATE: 1-1-88

INSTRUMENTS: 1-1-88
 DIMENSIONS: 1-1-88
 TOLERANCES: 1-1-88

UNLESS OTHERWISE SPECIFIED, ALL DIMENSIONS ARE IN INCHES.

DATE: 1-1-88
 DRAWING NO: A100779
 CUSTOMER DRAWING: 104354

DATE: 1-1-88
 SHEET: 1 OF 1