

CKTS	A	B	C
02	.262 6.65		.441 11.20
04	.380 9.65	.118 3.00	.559 14.20
06	.498 12.65	.236 6.00	.677 17.20
08	.616 15.65	.354 9.00	.795 20.20
10	.734 18.65	.472 12.00	.913 23.20
12	.852 21.65	.591 15.00	1.031 26.20
14	.970 24.65	.709 18.00	1.150 29.20
16	1.088 27.65	.827 21.00	1.268 32.20
18	1.206 30.65	.945 24.00	1.386 35.20
20	1.325 33.65	1.063 27.00	1.504 38.20
22	1.443 36.65	1.181 30.00	1.622 41.20
24	1.561 39.65	1.299 33.00	1.740 44.20

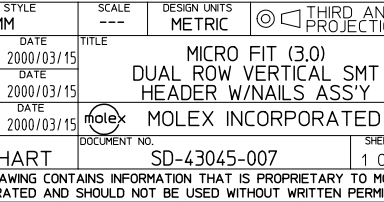
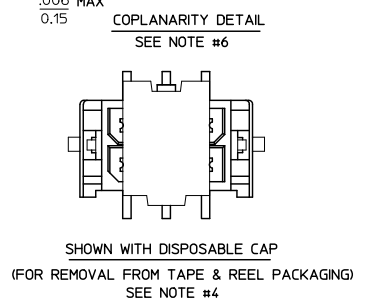
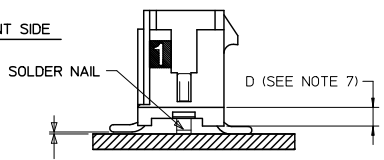

- NOTES:**
- HOUSING MATERIAL: GLASS FILLED LIQUID CRYSTAL POLYMER UL94V-0, COLOR: BLACK
TERMINAL MATERIAL: BRASS ALLOY
 - FINISH: A = .000100/(0.00254) MIN. TIN OVER .000050/(0.00127) MIN. NICKEL PLATE.
B = .000015/(0.00038) MIN. SELECT GOLD IN CONTACT AREA, .000100/(0.00254) MIN. SELECT MATTE TIN ON SOLDER TAILS, BOTH OVER .000050/(0.00127) MIN. NICKEL PLATE.
C = .000030/(0.00076) MIN. SELECT GOLD IN CONTACT AREA, .000100/(0.00254) MIN. SELECT MATTE TIN ON SOLDER TAILS, BOTH OVER .000050/(0.00127) MIN. NICKEL PLATE.
 - PRODUCT SPECIFICATION: PS-43045
 - TAPE AND REEL PACK : SEE MOLEX DRAWING PK-70873-05**
 - MATES WITH MICRO FIT (3.0) RECEPTACLE SERIES 43025
 - THE COPLANARITY DIMENSION IS ESTABLISHED BY PLACING THE ASSEMBLY ON A FLAT SURFACE. THE DISTANCE FROM THAT SURFACE TO THE BOTTOM OF ANY TERMINAL OR SOLDER NAIL MUST NOT EXCEED .006/0.15
 - CIRCUIT SIZES 2-6: 'D' IS 0.265/6.74 FOR .010/0.25 STEP.
CIRCUIT SIZES 8-24: 'D' IS .063/1.60 FOR .010/0.25 STEP.
 - THIS PART CONFORMS TO CLASS B REQUIREMENTS OF COSMETIC SPECIFICATION PS-45499-002.

	FINISH A	FINISH B	FINISH C
02	43045-0218	43045-0219	43045-0220
04	43045-0418	43045-0419	43045-0420
06	43045-0618	43045-0619	43045-0620
08	43045-0818	43045-0819	43045-0820
10	43045-1018	43045-1019	43045-1020
12	43045-1218	43045-1219	43045-1220
14	43045-1418	43045-1419	43045-1420
16	43045-1618	43045-1619	43045-1620
18	43045-1818	43045-1819	43045-1820
20	43045-2018	43045-2019	43045-2020
22	43045-2218	43045-2219	43045-2220
24	43045-2418	43045-2419	43045-2420

ADD 'D' DIM EC NO. UCP2011-0508 G. DRIVINGHARANI 2010/08/26 CHK:SSUSEK 2010/08/26 APPR:SMITH 2010/12/23	QUALITY SYMBOLS 	GENERAL TOLERANCES (UNLESS SPECIFIED)		DIMENSION STYLE		SCALE	DESIGN UNITS	THIRD ANGLE PROJECTION	
				IN/MM		---	METRIC		
		4 PLACES ±.005 ±.010		DRAWN BY DATE		TITLE			
		3 PLACES ±.010 ±.015		SAMI EC 2000/03/15		MICRO FIT (3.0) DUAL ROW VERTICAL SMT HEADER W/NAILS ASSY			
2 PLACES ±0.25 ±.014		CHECKED BY DATE		MOLEX INCORPORATED					
1 PLACE ±0.36 ±.014		MUELLER 2000/03/15							
ANGULAR ±1/2°		APPROVED BY DATE							
		EDGLEY 2000/03/15							
DRAFT WHERE APPLICABLE MUST REMAIN WITHIN DIMENSIONS		MATERIAL NO.		DOCUMENT NO.		SHEET NO.			
		SEE CHART		SD-43045-007		1 OF 1			
THIS DRAWING CONTAINS INFORMATION THAT IS PROPRIETARY TO MOLEX INCORPORATED AND SHOULD NOT BE USED WITHOUT WRITTEN PERMISSION									