

10 9 8 7 6 5 4 3 2 1

- NOTES :
1. MATERIAL:-
 - PIN:- (0.65)/.0255 SQ. BRASS WIRE.
 - HOUSING:- 15% GLASS FILLED POLYESTER
 - UL 94 V-0 COLOUR BLACK

2. FOR PLATING VERSIONS AND VOID VERSIONS
 SEE SHEET 2.

3. MEASUREMENT POINT FOR MINIMUM PLATING THICKNESS.

4. FOR PRODUCT SPEC SEE PS-99020-0001

5. RECOMMENDED PCB THICKNESS: 1.60mm

CKT	DIM A	DIM B	DIM C
6	(5.08)/ .200	(9.96)/ .392	(8.12)/ .320
8	(7.62)/ .300	(12.50)/ .492	(10.66)/ .420
10	(10.16)/ .400	(15.04)/ .592	(13.20)/ .520
12	(12.70)/ .500	(17.58)/ .692	(15.74)/ .620
14	(15.24)/ .600	(20.12)/ .792	(18.28)/ .720
16	(17.78)/ .700	(22.66)/ .892	(20.82)/ .820
18	(20.32)/ .800	(25.20)/ .992	(23.36)/ .920
20	(22.86)/ .900	(27.74)/ 1.092	(25.90)/ 1.020
22	(25.40)/ 1.000	(30.28)/ 1.192	(28.44)/ 1.120
24	(27.94)/ 1.100	(32.82)/ 1.292	(30.98)/ 1.220
26	(30.48)/ 1.200	(35.36)/ 1.392	(33.52)/ 1.320
28	(33.02)/ 1.300	(37.90)/ 1.492	(36.06)/ 1.420
30	(35.56)/ 1.400	(40.44)/ 1.592	(38.60)/ 1.520
32	(38.10)/ 1.500	(42.98)/ 1.692	(41.15)/ 1.620
34	(40.64)/ 1.600	(45.52)/ 1.792	(43.68)/ 1.720
36	(43.18)/ 1.700	(48.06)/ 1.892	(46.22)/ 1.820
38	(45.72)/ 1.800	(50.60)/ 1.992	(48.76)/ 1.920
40	(48.26)/ 1.900	(53.14)/ 2.092	(51.30)/ 2.020
42	(50.80)/ 2.000	(55.68)/ 2.192	(53.84)/ 2.120
44	(53.34)/ 2.100	(58.22)/ 2.292	(56.38)/ 2.220
46	(55.88)/ 2.200	(60.76)/ 2.392	(58.92)/ 2.320
48	(58.42)/ 2.300	(63.30)/ 2.492	(61.46)/ 2.420
50	(60.96)/ 2.400	(65.84)/ 2.592	(64.00)/ 2.520
52	(63.50)/ 2.500	(68.38)/ 2.692	(66.54)/ 2.620
54	(66.04)/ 2.600	(70.92)/ 2.792	(69.08)/ 2.720
56	(68.58)/ 2.700	(73.46)/ 2.892	(71.62)/ 2.820
58	(71.12)/ 2.800	(76.00)/ 2.992	(74.16)/ 2.920
60	(73.66)/ 2.900	(78.54)/ 3.092	(76.70)/ 3.020
62	(76.20)/ 3.000	(81.08)/ 3.192	(79.24)/ 3.120
64	(78.74)/ 3.100	(83.62)/ 3.292	(81.78)/ 3.220
66	(81.28)/ 3.200	(86.16)/ 3.392	(84.32)/ 3.320
68	(83.82)/ 3.300	(88.70)/ 3.492	(86.86)/ 3.420

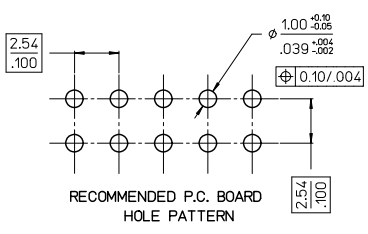
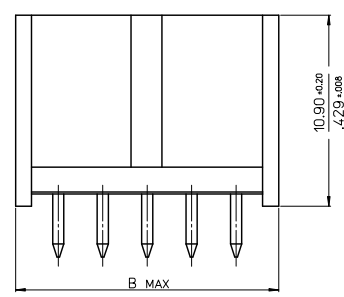
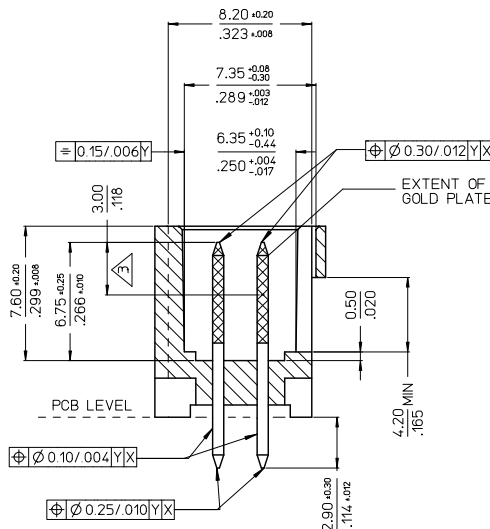
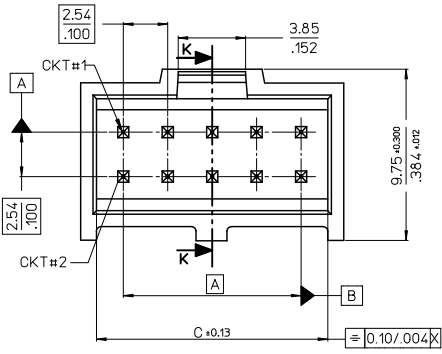

REVISED	DESCRIPTION	QUALITY SYMBOLS
EC NO: SZ2011-0579		▽=0
BY: DRWNSKANG		▽=0
CHKD: ATSEE		▽=0
APPR: MLONG		
DATE: 2011/03/08		
DATE: 2011/03/22		
DATE: 2011/03/22		

GENERAL TOLERANCES (UNLESS SPECIFIED)	
mm	INCH
4 PLACES ±	± ---
3 PLACES ±	± .004
2 PLACES ±	± 0.10
1 PLACE ±	± ---
ANGULAR ± 1/2°	
DRAFT WHERE APPLICABLE MUST REMAIN WITHIN DIMENSIONS	

DIMENSION STYLE	SCALE	DESIGN UNITS	THIRD ANGLE PROJECTION
MM/IN	NTS	METRIC	
DRAWN BY	DATE	TITLE	
KS	1988/08/23	C-GRID III	
CHECKED BY	DATE	DUAL ROW STRAIGHT	
ATSEE	2010/02/11	SHROUDED HEADER	
APPROVED BY	DATE	MOLEX INCORPORATED	
MLONG	2010/02/19		
MATERIAL NO.	DOCUMENT NO.	SHEET NO.	
SEE TABLE	SDA-90130	1 OF 4	

THIS DRAWING CONTAINS INFORMATION THAT IS PROPRIETARY TO MOLEX INCORPORATED AND SHOULD NOT BE USED WITHOUT WRITTEN PERMISSION

9 8 7 6 5 4 3 2 1

VERSION FULLY LOADED

NOTES :

- 1. FOR ASSEMBLY, SEE SHEET 1.
- 2. REFER TO LEGEND FOR PLATING OPTIONS.

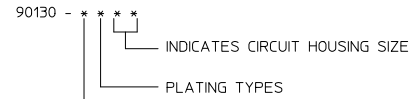

STYLE: - 1. STRAIGHT PIN VERSION
8. VERSION WITH VOIDS

- 1 - TYPE A:
3.04µm MIN. TIN OVER 1.27µm - 2.54µm NICKEL.
- 2 - TYPE B:
0.38µm MIN. GOLD IN SELECTED AREA & 3.04µm MIN. TIN IN SELECTED AREA OVER 1.3µm MIN. NICKEL OVERALL.
- 3 - TYPE C:
0.76µm MIN. GOLD IN SELECTED AREA & 3.04µm MIN. TIN IN SELECTED AREA OVER 1.3µm MIN. NICKEL OVERALL.
- 4 - TYPE D:
0.05 - 0.10µm GOLD FLASH IN SELECTED AREA & 3.04µm MIN. TIN IN SELECTED AREA OVER 1.3µm MIN. NICKEL OVERALL.

VOIDED OPTIONS

NO OF CKTS	HSG CKT SIZE	VOIDED PART NUMBER	VOID POSITION	PLATING TYPE
11	12	90130-8212	12	B
9	10	90130-8309	2	C
9	10	90130-8311	1	C
11	12	90130-8213	2	B
11	12	90130-8313	2	C

NO OF CKTS	HSG CKT SIZE	PART NUMBER			
		PLATING TYPE A	PLATING TYPE B	PLATING TYPE C	PLATING TYPE D
6	6	90130-X106	90130-X206	90130-X306	90130-X406
8	8	X108	X208	X308	X408
10	10	X110	X210	X310	X410
12	12	X112	X212	X312	X412
14	14	X114	X214	X314	X414
16	16	X116	X216	X316	X416
18	18	X118	X218	X318	X418
20	20	X120	X220	X320	X420
22	22	X122	X222	X322	X422
24	24	X124	X224	X324	X424
26	26	X126	X226	X326	X426
28	28	X128	X228	X328	X428
30	30	X130	X230	X330	X430
32	32	X132	X232	X332	X432
34	34	X134	X234	X334	X434
36	36	X136	X236	X336	X436
38	38	X138	X238	X338	X438
40	40	X140	X240	X340	X440
42	42	X142	X242	X342	X442
44	44	X144	X244	X344	X444
46	46	X146	X246	X346	X446
48	48	X148	X248	X348	X448
50	50	X150	X250	X350	X450
52	52	X152	X252	X352	X452
54	54	X154	X254	X354	X454
56	56	X156	X256	X356	X456
58	58	X158	X258	X358	X458
60	60	X160	X260	X360	X460
62	62	X162	X262	X362	X462
64	64	X164	X264	X364	X464
66	66	X166	X266	X366	X466
68	68	90130-X168	90130-X268	90130-X368	90130-X468

REVISED E.C. NO: S2011-0579 DRW:SKANG CHK:ATSEE APPR:MLONG 2011/03/08 2011/03/22 2011/03/22	QUALITY SYMBOLS ∇=0 ∇=0 ∇=0	GENERAL TOLERANCES (UNLESS SPECIFIED)		DIMENSION STYLE MM/IN		SCALE NTS	DESIGN UNITS METRIC	THIRD ANGLE PROJECTION	
		4 PLACES ± --- ± --- 3 PLACES ± --- ± .004 2 PLACES ± 0.10 ± --- 1 PLACE ± --- ± ---	mm INCH	DRAWN BY KS	DATE 1988/08/23	TITLE C-GRID III DUAL ROW STRAIGHT SHROUDED HEADER			
		ANGULAR ±1/2°	DRAFT WHERE APPLICABLE MUST REMAIN WITHIN DIMENSIONS	CHECKED BY ATSEE	DATE 2010/02/11	MOLEX INCORPORATED			
		MATERIAL NO. SEE TABLE	APPROVED BY MLONG	DATE 2010/02/19	DOCUMENT NO. SDA-90130	SHEET NO. 2 OF 4	THIS DRAWING CONTAINS INFORMATION THAT IS PROPRIETARY TO MOLEX INCORPORATED AND SHOULD NOT BE USED WITHOUT WRITTEN PERMISSION		

10 9 8 7 6 5 4 3 2 1

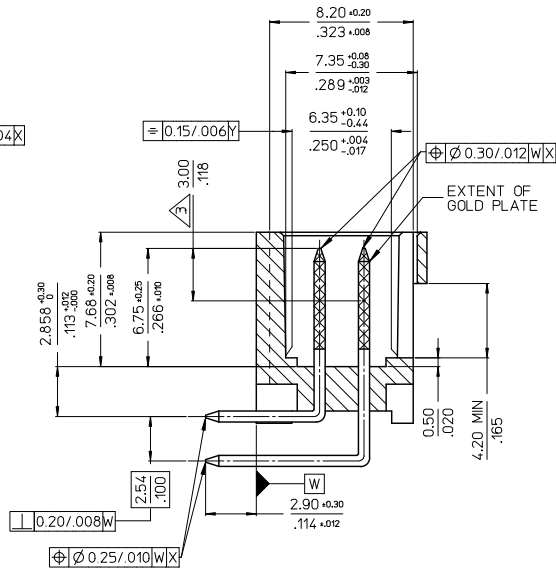
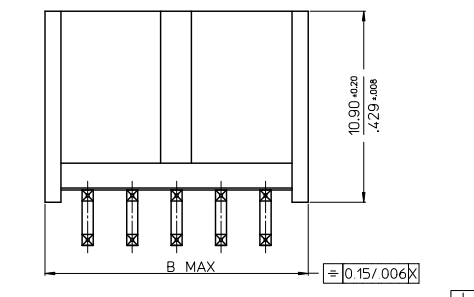
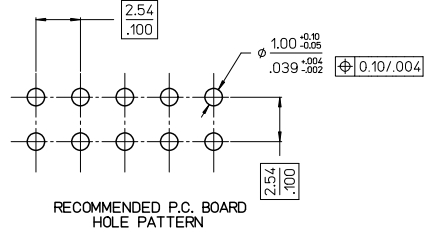
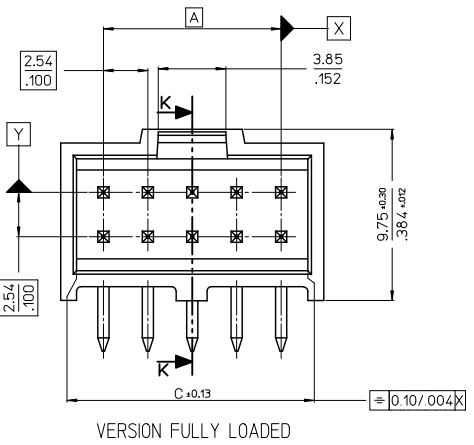

CKT	DIM A	DIM B	DIM C
6	(5.08)/ .200	(9.96)/ .392	(8.12)/ .320
8	(7.62)/ .300	(12.50)/ .492	(10.66)/ .420
10	(10.16)/ .400	(15.04)/ .592	(13.20)/ .520
12	(12.70)/ .500	(17.58)/ .692	(15.74)/ .620
14	(15.24)/ .600	(20.12)/ .792	(18.28)/ .720
16	(17.78)/ .700	(22.66)/ .892	(20.82)/ .820
18	(20.32)/ .800	(25.20)/ .992	(23.36)/ .920
20	(22.86)/ .900	(27.74)/ 1.092	(25.90)/ 1.020
22	(25.40)/ 1.000	(30.28)/ 1.192	(28.44)/ 1.120
24	(27.94)/ 1.100	(32.82)/ 1.292	(30.98)/ 1.220
26	(30.48)/ 1.200	(35.36)/ 1.392	(33.52)/ 1.320
28	(33.02)/ 1.300	(37.90)/ 1.492	(36.06)/ 1.420
30	(35.56)/ 1.400	(40.44)/ 1.592	(38.60)/ 1.520
32	(38.10)/ 1.500	(42.98)/ 1.692	(41.15)/ 1.620
34	(40.64)/ 1.600	(45.52)/ 1.792	(43.68)/ 1.720
36	(43.18)/ 1.700	(48.06)/ 1.892	(46.22)/ 1.820
38	(45.72)/ 1.800	(50.60)/ 1.992	(48.76)/ 1.920
40	(48.26)/ 1.900	(53.14)/ 2.092	(51.30)/ 2.020
42	(50.80)/ 2.000	(55.68)/ 2.192	(53.84)/ 2.120
44	(53.34)/ 2.100	(58.22)/ 2.292	(56.38)/ 2.220
46	(55.88)/ 2.200	(60.76)/ 2.392	(58.92)/ 2.320
48	(58.42)/ 2.300	(63.30)/ 2.492	(61.46)/ 2.420
50	(60.96)/ 2.400	(65.84)/ 2.592	(64.00)/ 2.520
52	(63.50)/ 2.500	(68.38)/ 2.692	(66.54)/ 2.620
54	(66.04)/ 2.600	(70.92)/ 2.792	(69.08)/ 2.720
56	(68.58)/ 2.700	(73.46)/ 2.892	(71.62)/ 2.820
58	(71.12)/ 2.800	(76.00)/ 2.992	(74.16)/ 2.920
60	(73.66)/ 2.900	(78.54)/ 3.092	(76.70)/ 3.020
62	(76.20)/ 3.000	(81.08)/ 3.192	(79.24)/ 3.120
64	(78.74)/ 3.100	(83.62)/ 3.292	(81.78)/ 3.220
66	(81.28)/ 3.200	(86.16)/ 3.392	(84.32)/ 3.320
68	(83.82)/ 3.300	(88.70)/ 3.492	(86.86)/ 3.420

- NOTES :
- MATERIAL:-
 - PIN:- (0.65)/.0255 SQ. BRASS WIRE.
 - HOUSING:- 15% GLASS FILLED POLYESTER
 - UL 94 V-0 COLOUR BLACK
 - FOR PLATING VERSIONS AND VOID VERSIONS SEE SHEET 2.
 - MEASUREMENT POINT FOR MINIMUM PLATING THICKNESS.
 - FOR PRODUCT SPEC SEE PS-99020-0001
 - RECOMMENDED PCB THICKNESS: 1.60mm

REVISED E.C. NO: S2011-0579 BY DRWNSKANG CHKD:ATSEE APPR:MLONG 2011/03/08 2011/03/22 2011/03/22	QUALITY SYMBOLS	GENERAL TOLERANCES (UNLESS SPECIFIED)	DIMENSION STYLE	SCALE	DESIGN UNITS	THIRD ANGLE PROJECTION															
	$\nabla = 0$ $\nabla = 0$ $\nabla = 0$	<table border="1"> <tr><th></th><th>mm</th><th>INCH</th></tr> <tr><td>4 PLACES</td><td>± .004</td><td>± .0004</td></tr> <tr><td>3 PLACES</td><td>± .004</td><td>± .0004</td></tr> <tr><td>2 PLACES</td><td>± 0.10</td><td>± .004</td></tr> <tr><td>1 PLACE</td><td>± .004</td><td>± .0004</td></tr> </table>		mm	INCH	4 PLACES	± .004	± .0004	3 PLACES	± .004	± .0004	2 PLACES	± 0.10	± .004	1 PLACE	± .004	± .0004	MM/IN	NTS	METRIC	
		mm	INCH																		
	4 PLACES	± .004	± .0004																		
3 PLACES	± .004	± .0004																			
2 PLACES	± 0.10	± .004																			
1 PLACE	± .004	± .0004																			
DESCRIPTION	DRAFT WHERE APPLICABLE MUST REMAIN WITHIN DIMENSIONS	DRAWN BY: KS CHECKED BY: ATSEE APPROVED BY: MLONG DATE: 1988/08/23 DATE: 2010/02/11 DATE: 2010/02/19	TITLE	C-GRID III DUAL ROW STRAIGHT SHROUDED HEADER																	
REV			MATERIAL NO. SEE TABLE	DOCUMENT NO. SDA-90130	SHEET NO. 3 OF 4	MOLEX INCORPORATED															

VERSION FULLY LOADED

NO OF CKTS	HSG CKT SIZE	PART NUMBER		
		PLATING TYPE A	PLATING TYPE B	PLATING TYPE C
6	6	90130-X106	90130-X206	90130-X306
8	8	X108	X208	X308
10	10	X110	X210	X310
12	12	X112	X212	X312
14	14	X114	X214	X314
16	16	X116	X216	X316
18	18	X118	X218	X318
20	20	X120	X220	X320
22	22	X122	X222	X322
24	24	X124	X224	X324
26	26	X126	X226	X326
28	28	X128	X228	X328
30	30	X130	X230	X330
32	32	X132	X232	X332
34	34	X134	X234	X334
36	36	X136	X236	X336
38	38	X138	X238	X338
40	40	X140	X240	X340
42	42	X142	X242	X342
44	44	X144	X244	X344
46	46	X146	X246	X346
48	48	X148	X248	X348
50	50	X150	X250	X350
52	52	X152	X252	X352
54	54	X154	X254	X354
56	56	X156	X256	X356
58	58	X158	X258	X358
60	60	X160	X260	X360
62	62	X162	X262	X362
64	64	X164	X264	X364
66	66	X166	X266	X366
68	68	90130-X168	90130-X268	90130-X368

NOTES :
 1. FOR ASSEMBLY, SEE SHEET 1.
 2. REFER TO LEGEND FOR PLATING OPTIONS



STYLE: - 3. RIGHT ANGLE VERSION

- 1 - TYPE A:
3.0µm MIN. TIN OVER 1.27µm - 2.54µm NICKEL.
- 2 - TYPE B:
0.38µm MIN. GOLD IN SELECTED AREA & 3.0µm MIN. TIN IN SELECTED AREA OVER 1.3µm MIN. NICKEL OVERALL.
- 3 - TYPE C:
0.76µm MIN. GOLD IN SELECTED AREA & 3.0µm MIN. TIN IN SELECTED AREA OVER 1.3µm MIN. NICKEL OVERALL.

REVISED EC NO: S2011-0579 DRAWNSKANG CHKD:ATSEE APPR:MLONG	DESCRIPTION 2011/03/08 2011/03/22 2011/03/22	QUALITY SYMBOLS	GENERAL TOLERANCES (UNLESS SPECIFIED)	DIMENSION STYLE	SCALE	DESIGN UNITS	THIRD ANGLE PROJECTION
		▽=0	mm INCH	MM/IN	NTS	METRIC	
		▽=0	4 PLACES ± --- ± ---	DRAWN BY DATE	TITLE C-GRID III DUAL ROW STRAIGHT SHROUDED HEADER		
		▽=0	3 PLACES ± --- ± .004	KS 1988/08/23			
▽=0	2 PLACES ± 0.10 ± ---	CHECKED BY DATE					
		1 PLACE ± --- ± ---	ATSEE 2010/02/11				
		ANGULAR ±1/2°	APPROVED BY DATE				
		DRAFT WHERE APPLICABLE MUST REMAIN WITHIN DIMENSIONS	MLONG 2010/02/19	MATERIAL NO.	DOCUMENT NO.		
			SEE TABLE				
			SIZE A3	THIS DRAWING CONTAINS INFORMATION THAT IS PROPRIETARY TO MOLEX INCORPORATED AND SHOULD NOT BE USED WITHOUT WRITTEN PERMISSION			