

CKT SIZE	DIM. "A"		DIM. "B"		CKT SIZE	DIM. "A"		DIM. "B"	
2X 1			(2.54)	.100	2X21	(50.80)	2.000	(53.34)	2.100
2X 2	(2.54)	.100	(5.08)	.200	2X22	(53.34)	2.100	(55.88)	2.200
2X 3	(5.08)	.200	(7.62)	.300	2X23	(55.88)	2.200	(58.42)	2.300
2X 4	(7.62)	.300	(10.16)	.400	2X24	(58.42)	2.300	(60.96)	2.400
2X 5	(10.16)	.400	(12.70)	.500	2X25	(60.96)	2.400	(63.50)	2.500
2X 6	(12.70)	.500	(15.24)	.600	2X26	(63.50)	2.500	(66.04)	2.600
2X 7	(15.24)	.600	(17.78)	.700	2X27	(66.04)	2.600	(68.58)	2.700
2X 8	(17.78)	.700	(20.32)	.800	2X28	(68.58)	2.700	(71.12)	2.800
2X 9	(20.32)	.800	(22.86)	.900	2X29	(71.12)	2.800	(73.66)	2.900
2X 10	(22.86)	.900	(25.40)	1.000	2X30	(73.66)	2.900	(76.20)	3.000
2X 11	(25.40)	1.000	(27.94)	1.100	2X31	(76.20)	3.000	(78.74)	3.100
2X 12	(27.94)	1.100	(30.48)	1.200	2X32	(78.74)	3.100	(81.28)	3.200
2X 13	(30.48)	1.200	(33.02)	1.300	2X33	(81.28)	3.200	(83.82)	3.300
2X 14	(33.02)	1.300	(35.56)	1.400	2X34	(83.82)	3.300	(86.36)	3.400
2X 15	(35.56)	1.400	(38.10)	1.500	2X35	(86.36)	3.400	(88.90)	3.500
2X 16	(38.10)	1.500	(40.64)	1.600	2X36	(88.90)	3.500	(91.44)	3.600
2X 17	(40.64)	1.600	(43.18)	1.700	2X37	(91.44)	3.600	(93.98)	3.700
2X 18	(43.18)	1.700	(45.72)	1.800	2X38	(93.98)	3.700	(96.52)	3.800
2X 19	(45.72)	1.800	(48.26)	1.900	2X39	(96.52)	3.800	(99.06)	3.900
2X 20	(48.26)	1.900	(50.80)	2.000	2X40	(99.06)	3.900	(101.60)	4.000

NOTES  
1. FOR ASSY NUMBERS WITH FINISH OPTIONS AND DIM'S C & D SEE SHEETS 2 TO 7.

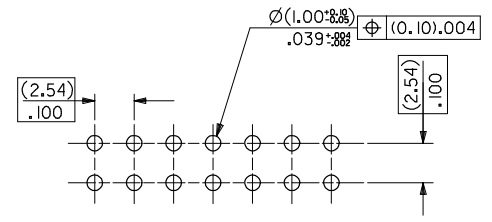
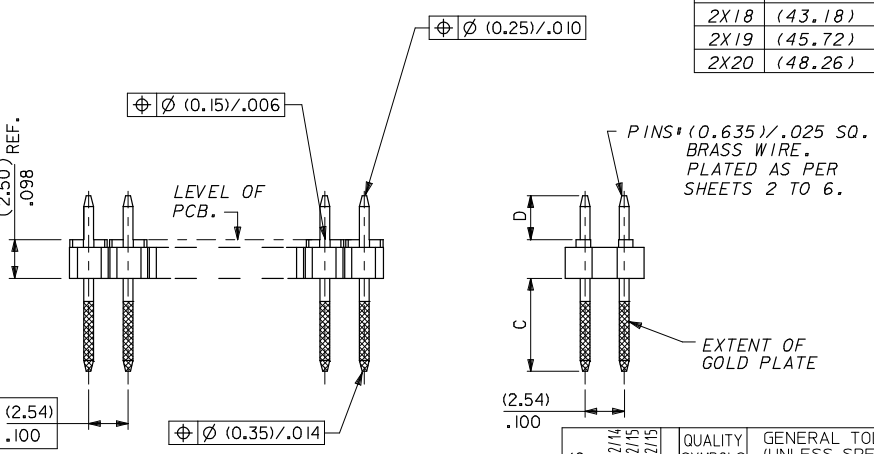

RECOMMENDED P.C. BOARD HOLE PATTERN

NOTES  
2. RECOMMENDED PCB THICKNESS 1.6MM  
3. PRODUCT SPECIFICATION: PS-99020-0001

ADDED NOTES EC NO: E2008-0337 DRW: K. TERMAN CHKD: M. K. TERMAN APPR: B. MAGUIRE 2008/02/14 2008/02/15 2008/02/15	QUALITY SYMBOLS ▽ = ▽ = ▽ =	GENERAL TOLERANCES (UNLESS SPECIFIED) mm INCH 4 PLACES ± --- ± --- 3 PLACES ± --- ± --- 2 PLACES ± --- ± --- 1 PLACE ± --- ± --- ANGULAR ± --- °	DIMENSION STYLE MM ONLY DRAWN BY: DB DATE: 16/7/87 CHECKED BY: DATE: APPROVED BY: DATE:	SCALE: 4:1 DESIGN UNITS: METRIC THIRD ANGLE PROJECTION	TITLE: C GRID III DUAL ROW STRAIGHT PIN HEADER MOLEX INCORPORATED MATERIAL NO. SEE CHART DOCUMENT NO. SDA-90131 SHEET NO. 1 OF 7
		DRAFT WHERE APPLICABLE MUST REMAIN WITHIN DIMENSIONS		THIS DRAWING CONTAINS INFORMATION THAT IS PROPRIETARY TO MOLEX INCORPORATED AND SHOULD NOT BE USED WITHOUT WRITTEN PERMISSION	
		SIZE A 3			

PART NO. SEE CHART  
DWC. NO. SDA-90131

DIM C (+0.20) ±.008 (6.75) .266

DIM D (+0.20) ±.008 (2.90) .114

CIRCUIT SIZE	PLATING TYPE A PART NO.	PLATING TYPE E PART NO.	PLATING TYPE F PART NO.
2 X 1	90131-0121	90131-0761	90131-0921
2 X 2	-0122	-0762	-0922
2 X 3	-0123	-0763	-0923
2 X 4	-0124	-0764	-0924
2 X 5	-0125	-0765	-0925
2 X 6	-0126	-0766	-0926
2 X 7	-0127	-0767	-0927
2 X 8	-0128	-0768	-0928
2 X 9	-0129	-0769	-0929
2 X 10	-0130	-0770	-0930
2 X 11	-0131	-0771	-0931
2 X 12	-0132	-0772	-0932
2 X 13	-0133	-0773	-0933
2 X 14	-0134	-0774	-0934
2 X 15	-0135	-0775	-0935
2 X 16	-0136	-0776	-0936
2 X 17	-0137	-0777	-0937
2 X 18	-0138	-0778	-0938
2 X 19	-0139	-0779	-0939
2 X 20	-0140	-0780	-0940
2 X 21	-0141	-0781	-0941
2 X 22	-0142	-0782	-0942
2 X 23	-0143	-0783	-0943
2 X 24	-0144	-0784	-0944
2 X 25	-0145	-0785	-0945
2 X 26	-0146	-0786	-0946
2 X 27	-0147	-0787	-0947
2 X 28	-0148	-0788	-0948
2 X 29	-0149	-0789	-0949
2 X 30	-0150	-0790	-0950
2 X 31	-0151	-0791	-0951
2 X 32	-0152	-0792	-0952
2 X 33	-0153	-0793	-0953
2 X 34	-0154	-0794	-0954
2 X 35	-0155	-0795	-0955
2 X 36	-0156	-0796	-0956
2 X 37	-0157	-0797	-0957
2 X 38	-0158	-0798	-0958
2 X 39	-0159	-0799	-0959
2 X 40	90131-0160	90131-0800	90131-0960

NOTES:  
FOR PLATING VARIATIONS SEE  
ENG.STD. SDES-99000-0003.

**STANDARD PRODUCTS**

FOR PREVIOUS DRAWING ISSUES SEE MRI.	SEE SHEET I.	H	LTR	REVISIONS	DIMENSIONS SHOWN ( METRIC ) INCH	DRWG BY	REVISE ONLY ON CAD SYSTEM		SH.	REV.	
					UNLESS OTHERWISE SPECIFIED TOLERANCES: ANGULAR ± 8	DB	CAD/CAM FILENAME	THIS DRAWING CONTAINS INFORMATION THAT IS PROPRIETARY TO MOLEX INC. & SHOULD NOT BE USED WITHOUT WRITTEN PERMISSION			
					3 PLACE ± .000	CHK'D BY	TITLE	C-GRID III DUAL ROW STRAIGHT PIN HEADER			
					2 PLACE ± .001	APP'D BY	MOLEX EUROPE		SHEET NO.	DATE	
1 PLACE ± .005	SCALE	PART NO.		DWG NO.	SIZE						
			DESIGN DIMENSION (PRIMARY) <input checked="" type="checkbox"/> (MM) <input type="checkbox"/> IN.		SEE CHART		20F		16/ 7/87		
			EQUIVALENT DIMENSION (SECONDARY) <input type="checkbox"/> (MM) <input checked="" type="checkbox"/> IN.				SDA-90131		B		

7132-1283