

10 9 8 7 6 5 4 3 2 1

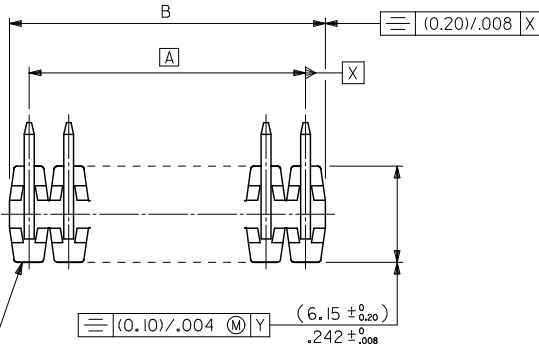

CKT SIZE	DIM. "A"		DIM. "B" <sup>(+0.20 / -0.008)</sup>		CKT SIZE	DIM. "A"		DIM. "B" <sup>(+0.20 / -0.008)</sup>	
2X 1			(2.54)	.100	2X21	(50.80)	2.000	(53.34)	2.100
2X 2	(2.54)	.100	(5.08)	.200	2X22	(53.34)	2.100	(55.88)	2.200
2X 3	(5.08)	.200	(7.62)	.300	2X23	(55.88)	2.200	(58.42)	2.300
2X 4	(7.62)	.300	(10.16)	.400	2X24	(58.42)	2.300	(60.96)	2.400
2X 5	(10.16)	.400	(12.70)	.500	2X25	(60.96)	2.400	(63.50)	2.500
2X 6	(12.70)	.500	(15.24)	.600	2X26	(63.50)	2.500	(66.04)	2.600
2X 7	(15.24)	.600	(17.78)	.700	2X27	(66.04)	2.600	(68.58)	2.700
2X 8	(17.78)	.700	(20.32)	.800	2X28	(68.58)	2.700	(71.12)	2.800
2X 9	(20.32)	.800	(22.86)	.900	2X29	(71.12)	2.800	(73.66)	2.900
2X10	(22.86)	.900	(25.40)	1.000	2X30	(73.66)	2.900	(76.20)	3.000
2X11	(25.40)	1.000	(27.94)	1.100	2X31	(76.20)	3.000	(78.74)	3.100
2X12	(27.94)	1.100	(30.48)	1.200	2X32	(78.74)	3.100	(81.28)	3.200
2X13	(30.48)	1.200	(33.02)	1.300	2X33	(81.28)	3.200	(83.82)	3.300
2X14	(33.02)	1.300	(35.56)	1.400	2X34	(83.82)	3.300	(86.36)	3.400
2X15	(35.56)	1.400	(38.10)	1.500	2X35	(86.36)	3.400	(88.90)	3.500
2X16	(38.10)	1.500	(40.64)	1.600	2X36	(88.90)	3.500	(91.44)	3.600
2X17	(40.64)	1.600	(43.18)	1.700	2X37	(91.44)	3.600	(93.98)	3.700
2X18	(43.18)	1.700	(45.72)	1.800	2X38	(93.98)	3.700	(96.52)	3.800
2X19	(45.72)	1.800	(48.26)	1.900	2X39	(96.52)	3.800	(99.06)	3.900
2X20	(48.26)	1.900	(50.80)	2.000	2X40	(99.06)	3.900	(101.60)	4.000

WAFFER\* 15% GLASS FILLED POLYESTER TO UL 94V-0. COLOUR \* BLACK.

PINS\* (0.635) / .025 SQ. BRASS WIRE. PLATED AS PER SHEETS 2 TO 6.

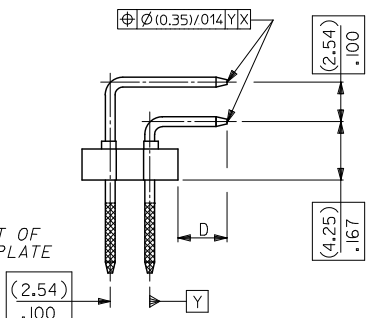
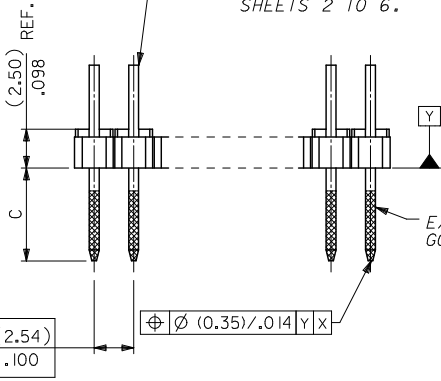

NOTES  
1. FOR ASSY NUMBERS WITH FINISH OPTIONS AND DIM'S C & D SEE SHEETS 2 TO 6.

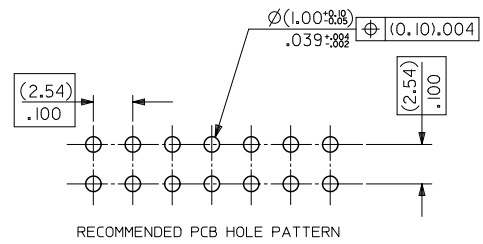

NOTES  
2. RECOMMENDED PCB THICKNESS: 1.6MM  
3. PRODUCT SPECIFICATION: PS-99020-0001

UPDATE TOL SYMMETRY	2010/04/15	
EC NO: S2010-0867	DRWNSKANG	2010/04/27
	CHKD:ATSEE	2010/04/27
	APPR:MLONG	2010/04/27
M1	REV	

QUALITY SYMBOLS	GENERAL TOLERANCES (UNLESS SPECIFIED)	
	mm	INCH
▽=0	4 PLACES ±---	±---
▽=0	3 PLACES ±---	±---
▽=0	2 PLACES ±---	±---
▽=0	1 PLACE ±---	±---
	ANGULAR ±---	°

DIMENSION STYLE		SCALE	DESIGN UNITS	THIRD ANGLE PROJECTION
MM ONLY		NTS	METRIC	☉
DRAWN BY	DATE	TITLE		
DB	16/07/87	C-GRID III		
CHECKED BY	DATE	DUAL ROW RIGHT		
ATSEE	2010/04/27	ANGLE HEADER		
APPROVED BY	DATE	molex MOLEX INCORPORATED		
MLONG	2010/04/27	SDA-90122		
MATERIAL NO.	DOCUMENT NO.	SHEET NO.		
SEE TABLE		1 OF 6		

DRAFT WHERE APPLICABLE MUST REMAIN WITHIN DIMENSIONS

THIS DRAWING CONTAINS INFORMATION THAT IS PROPRIETARY TO MOLEX INCORPORATED AND SHOULD NOT BE USED WITHOUT WRITTEN PERMISSION

10 9 8 7 6 5 4 3 2 1

CIRCUIT SIZE	PLATING TYPE A PART NO.	PLATING TYPE E PART NO.	PLATING TYPE F PART NO.
2 X 1	90122-0121	90122-0761	90122-0921
2 X 2	▲ -0122	▲ -0762	▲ -0922
2 X 3	-0123	-0763	-0923
2 X 4	-0124	-0764	-0924
2 X 5	-0125	-0765	-0925
2 X 6	-0126	-0766	-0926
2 X 7	-0127	-0767	-0927
2 X 8	-0128	-0768	-0928
2 X 9	-0129	-0769	-0929
2 X 10	-0130	-0770	-0930
2 X 11	-0131	-0771	-0931
2 X 12	-0132	-0772	-0932
2 X 13	-0133	-0773	-0933
2 X 14	-0134	-0774	-0934
2 X 15	-0135	-0775	-0935
2 X 16	-0136	-0776	-0936
2 X 17	-0137	-0777	-0937
2 X 18	-0138	-0778	-0938
2 X 19	-0139	-0779	-0939
2 X 20	-0140	-0780	-0940
2 X 21	-0141	-0781	-0941
2 X 22	-0142	-0782	-0942
2 X 23	-0143	-0783	-0943
2 X 24	-0144	-0784	-0944
2 X 25	-0145	-0785	-0945
2 X 26	-0146	-0786	-0946
2 X 27	-0147	-0787	-0947
2 X 28	-0148	-0788	-0948
2 X 29	-0149	-0789	-0949
2 X 30	-0150	-0790	-0950
2 X 31	-0151	-0791	-0951
2 X 32	-0152	-0792	-0952
2 X 33	-0153	-0793	-0953
2 X 34	-0154	-0794	-0954
2 X 35	-0155	-0795	-0955
2 X 36	-0156	-0796	-0956
2 X 37	-0157	-0797	-0957
2 X 38	-0158	-0798	-0958
2 X 39	▼ -0159	▼ -0799	▼ -0959
2 X 40	90122-0160	90122-0800	90122-0960

DIM C (±0.25) ±.008 (6.75) .266

DIM D (±0.25) ±.010 (2.90) .114

NOTES:  
FOR PLATING VARIATIONS SEE  
ENG.STD. SDES-99000-0003.

UPDATE TOL SYMMETRY	2010/04/15
EC NO: S2010-0867	2010/04/27
DRWNSKANG	2010/04/27
CHKD:ATSEE	2010/04/27
APPR:MLONG	2010/04/27
REV	DESCRIPTION
M1	

QUALITY SYMBOLS	GENERAL TOLERANCES (UNLESS SPECIFIED)		DIMENSION STYLE	SCALE	DESIGN UNITS	THIRD ANGLE PROJECTION
	mm	INCH	MM ONLY	NTS	METRIC	
▽=0	4 PLACES ± --- ± ---	3 PLACES ± --- ± ---	DRAWN BY	DATE	TITLE	
▽=0	2 PLACES ± --- ± ---	1 PLACE ± --- ± ---	DB	16/07/87	C-GRID III DUAL ROW RIGHT ANGLE HEADER	
▽=0	ANGULAR ± --- °		CHECKED BY	DATE	MOLEX INCORPORATED	
	DRAFT WHERE APPLICABLE MUST REMAIN WITHIN DIMENSIONS		ATSEE	2010/04/27	MATERIAL NO. SDA-90122	
			APPROVED BY	DATE	DOCUMENT NO. SHEET NO.	
			MLONG	2010/04/27	SDA-90122 2 OF 6	
			MATERIAL NO.	SEE TABLE	THIS DRAWING CONTAINS INFORMATION THAT IS PROPRIETARY TO MOLEX INCORPORATED AND SHOULD NOT BE USED WITHOUT WRITTEN PERMISSION	
			SIZE	A3		

tb\_frame\_A3\_P\_AM.T  
Rev. F 2009/06/18

9 8 7 6 5 4 3 2 1

	10	9	8	7	6	5	4	3	2	1
	CIRCUIT SIZE	PLATING TYPE A PART NO.	PLATING TYPE E PART NO.	PLATING TYPE F PART NO.			CIRCUIT SIZE	PLATING TYPE A PART NO.	PLATING TYPE E PART NO.	PLATING TYPE F PART NO.
	2 X 1	90122-0041	90122-0681	90122-0841			2 X 1	90122-0081	90122-0721	90122-0881
	2 X 2	▲ -0042	▲ -0682	▲ -0842			2 X 2	▲ -0082	▲ -0722	▲ -0882
	2 X 3	-0043	-0683	-0843			2 X 3	-0083	-0723	-0883
	2 X 4	-0044	-0684	-0844			2 X 4	-0084	-0724	-0884
	2 X 5	-0045	-0685	-0845			2 X 5	-0085	-0725	-0885
	2 X 6	-0046	-0686	-0846			2 X 6	-0086	-0726	-0886
	2 X 7	-0047	-0687	-0847			2 X 7	-0087	-0727	-0887
	2 X 8	-0048	-0688	-0848			2 X 8	-0088	-0728	-0888
	2 X 9	-0049	-0689	-0849			2 X 9	-0089	-0729	-0889
	2 X 10	-0050	-0690	-0850			2 X 10	-0090	-0730	-0890
	2 X 11	-0051	-0691	-0851			2 X 11	-0091	-0731	-0891
	2 X 12	-0052	-0692	-0852			2 X 12	-0092	-0732	-0892
	2 X 13	-0053	-0693	-0853			2 X 13	-0093	-0733	-0893
	2 X 14	-0054	-0694	-0854			2 X 14	-0094	-0734	-0894
	2 X 15	-0055	-0695	-0855			2 X 15	-0095	-0735	-0895
	2 X 16	-0056	-0696	-0856			2 X 16	-0096	-0736	-0896
	2 X 17	-0057	-0697	-0857			2 X 17	-0097	-0737	-0897
	2 X 18	-0058	-0698	-0858			2 X 18	-0098	-0738	-0898
	2 X 19	-0059	-0699	-0859			2 X 19	-0099	-0739	-0899
	2 X 20	-0060	-0700	-0860			2 X 20	-0100	-0740	-0900
	2 X 21	-0061	-0701	-0861			2 X 21	-0101	-0741	-0901
	2 X 22	-0062	-0702	-0862			2 X 22	-0102	-0742	-0902
	2 X 23	-0063	-0703	-0863			2 X 23	-0103	-0743	-0903
	2 X 24	-0064	-0704	-0864			2 X 24	-0104	-0744	-0904
	2 X 25	-0065	-0705	-0865			2 X 25	-0105	-0745	-0905
	2 X 26	-0066	-0706	-0866			2 X 26	-0106	-0746	-0906
	2 X 27	-0067	-0707	-0867			2 X 27	-0107	-0747	-0907
	2 X 28	-0068	-0708	-0868			2 X 28	-0108	-0748	-0908
	2 X 29	-0069	-0709	-0869			2 X 29	-0109	-0749	-0909
	2 X 30	-0070	-0710	-0870			2 X 30	-0110	-0750	-0910
	2 X 31	-0071	-0711	-0871			2 X 31	-0111	-0751	-0911
	2 X 32	-0072	-0712	-0872			2 X 32	-0112	-0752	-0912
	2 X 33	-0073	-0713	-0873			2 X 33	-0113	-0753	-0913
	2 X 34	-0074	-0714	-0874			2 X 34	-0114	-0754	-0914
	2 X 35	-0075	-0715	-0875			2 X 35	-0115	-0755	-0915
	2 X 36	-0076	-0716	-0876			2 X 36	-0116	-0756	-0916
	2 X 37	-0077	-0717	-0877			2 X 37	-0117	-0757	-0917
	2 X 38	-0078	-0718	-0878			2 X 38	-0118	-0758	-0918
	2 X 39	▼ -0079	▼ -0719	▼ -0879			2 X 39	▼ -0119	▼ -0759	▼ -0919
	2 X 40	90122-0080	90122-0720	90122-0880			2 X 40	90122-0120	90122-0760	90122-0920

DIM C (±0.25) ±.008 (5.75) .226

DIM C (±0.25) ±.008 (5.75) .226

DIM D (±0.25) ±.010 (2.90) .114

DIM D (±0.25) ±.010 (4.50) .177

NOTES:  
FOR PLATING VARIATIONS SEE  
ENG.STD. SDES-99000-0003.

UPDATE TOL SYMMETRY  
EC NO: S2010-0867  
2010/04/15  
DRW:SKANG  
CHK:ATSEE  
2010/04/27  
APPR:MLONG  
2010/04/27

QUALITY SYMBOLS  
▽=0  
▽=0  
▽=0

GENERAL TOLERANCES (UNLESS SPECIFIED)

	mm	INCH
4 PLACES	±.004	±.00016
3 PLACES	±.005	±.00020
2 PLACES	±.007	±.00028
1 PLACE	±.010	±.00040
ANGULAR ±.005°		

DRAFT WHERE APPLICABLE  
MUST REMAIN  
WITHIN DIMENSIONS

DIMENSION STYLE  
MM ONLY

DRAWN BY: DB  
DATE: 16/07/87

CHECKED BY: ATSEE  
DATE: 2010/04/27

APPROVED BY: MLONG  
DATE: 2010/04/27

MATERIAL NO. SEE TABLE

SCALE: NTS  
DESIGN UNITS: METRIC  
THIRD ANGLE PROJECTION

C-GRID III  
DUAL ROW RIGHT  
ANGLE HEADER

MOLEX INCORPORATED

DOCUMENT NO. SDA-90122

SHEET NO. 3 OF 6

THIS DRAWING CONTAINS INFORMATION THAT IS PROPRIETARY TO MOLEX INCORPORATED AND SHOULD NOT BE USED WITHOUT WRITTEN PERMISSION

	10	9	8	7	6	5	4	3	2	1	
	CIRCUIT SIZE	PLATING TYPE A PART NO.	PLATING TYPE E PART NO.	PLATING TYPE F PART NO.							
	2 X 1	90122-0161	90122-0801	90122-0961							
	2 X 2	↑ -0162	↑ -0802	↑ -0962							
	2 X 3	-0163	-0803	-0963							
	2 X 4	-0164	-0804	-0964							
	2 X 5	-0165	-0805	-0965							
	2 X 6	-0166	-0806	-0966							
	2 X 7	-0167	-0807	-0967							
	2 X 8	-0168	-0808	-0968							
	2 X 9	-0169	-0809	-0969							
	2 X 10	-0170	-0810	-0970							
	2 X 11	-0171	-0811	-0971							
	2 X 12	-0172	-0812	-0972							
	2 X 13	-0173	-0813	-0973							
	2 X 14	-0174	-0814	-0974							
	2 X 15	-0175	-0815	-0975							
	2 X 16	-0176	-0816	-0976							
	2 X 17	-0177	-0817	-0977							
	2 X 18	-0178	-0818	-0978							
	2 X 19	-0179	-0819	-0979							
	2 X 20	-0180	-0820	-0980							
	2 X 21	-0181	-0821	-0981							
	2 X 22	-0182	-0822	-0982							
	2 X 23	-0183	-0823	-0983							
	2 X 24	-0184	-0824	-0984							
	2 X 25	-0185	-0825	-0985							
	2 X 26	-0186	-0826	-0986							
	2 X 27	-0187	-0827	-0987							
	2 X 28	-0188	-0828	-0988							
	2 X 29	-0189	-0829	-0989							
	2 X 30	-0190	-0830	-0990							
	2 X 31	-0191	-0831	-0991							
	2 X 32	-0192	-0832	-0992							
	2 X 33	-0193	-0833	-0993							
	2 X 34	-0194	-0834	-0994							
	2 X 35	-0195	-0835	-0995							
	2 X 36	-0196	-0836	-0996							
	2 X 37	-0197	-0837	-0997							
	2 X 38	-0198	-0838	-0998							
	2 X 39	↓ -0199	↓ -0839	↓ -0999							
	2 X 40	90122-0200	90122-0840	90122-1000							

NOTES:  
FOR PLATING VARIATIONS SEE  
ENG.STD. SDES-99000-0003.

UPDATE TOL SYMMETRY	2010/04/15	DRWNSKANG	2010/04/27	QUALITY SYMBOLS	GENERAL TOLERANCES (UNLESS SPECIFIED)	DIMENSION STYLE		SCALE	DESIGN UNITS	THIRD ANGLE PROJECTION
EC NO: S2010-0867	2010/04/15	CHYKATSEE	2010/04/27			mm	INCH	NTS	METRIC	
M1	APPR:MLONG	2010/04/27	2010/04/27	▽=0	4 PLACES ± --- ± ---	DRAWN BY		DATE	TITLE	
				▽=0	3 PLACES ± --- ± ---	DB		16/07/87	C-GRID III DUAL ROW RIGHT ANGLE HEADER	
				▽=0	2 PLACES ± --- ± ---	CHECKED BY		DATE	MOLEX INCORPORATED	
					1 PLACE ± --- ± ---	ATSEE		2010/04/27		
					ANGULAR ± --- °	APPROVED BY		DATE	SDA-90122	
						MLONG		2010/04/27		
					DRAFT WHERE APPLICABLE MUST REMAIN WITHIN DIMENSIONS	MATERIAL NO.		SEE TABLE	DOCUMENT NO.	
						SIZE		A3	SHEET NO.	
						THIS DRAWING CONTAINS INFORMATION THAT IS PROPRIETARY TO MOLEX INCORPORATED AND SHOULD NOT BE USED WITHOUT WRITTEN PERMISSION				

	10	9	8	7	6	5	4	3	2	1	
	CIRCUIT SIZE	PLATING TYPE B PART NO.	PLATING TYPE C PART NO.	PLATING TYPE D PART NO.	PLATING TYPE G PART NO.		CIRCUIT SIZE	PLATING TYPE B PART NO.	PLATING TYPE C PART NO.	PLATING TYPE D PART NO.	PLATING TYPE G PART NO.
F	2 X 1	90122-0281	90122-0441	90122-0601	90122-1081		2 X 1	90122-0201	90122-0361	90122-0521	90122-1001
	2 X 2	-0282	-0442	-0602	-1082		2 X 2	-0202	-0362	-0522	-1002
	2 X 3	-0283	-0443	-0603	-1083		2 X 3	-0203	-0363	-0523	-1003
	2 X 4	-0284	-0444	-0604	-1084		2 X 4	-0204	-0364	-0524	-1004
	2 X 5	-0285	-0445	-0605	-1085		2 X 5	-0205	-0365	-0525	-1005
	2 X 6	-0286	-0446	-0606	-1086		2 X 6	-0206	-0366	-0526	-1006
	2 X 7	-0287	-0447	-0607	-1087		2 X 7	-0207	-0367	-0527	-1007
	2 X 8	-0288	-0448	-0608	-1088		2 X 8	-0208	-0368	-0528	-1008
	2 X 9	-0289	-0449	-0609	-1089		2 X 9	-0209	-0369	-0529	-1009
E	2 X 10	-0290	-0450	-0610	-1090		2 X 10	-0210	-0370	-0530	-1010
	2 X 11	-0291	-0451	-0611	-1091		2 X 11	-0211	-0371	-0531	-1011
	2 X 12	-0292	-0452	-0612	-1092		2 X 12	-0212	-0372	-0532	-1012
	2 X 13	-0293	-0453	-0613	-1093		2 X 13	-0213	-0373	-0533	-1013
	2 X 14	-0294	-0454	-0614	-1094		2 X 14	-0214	-0374	-0534	-1014
	2 X 15	-0295	-0455	-0615	-1095		2 X 15	-0215	-0375	-0535	-1015
	2 X 16	-0296	-0456	-0616	-1096		2 X 16	-0216	-0376	-0536	-1016
	2 X 17	-0297	-0457	-0617	-1097		2 X 17	-0217	-0377	-0537	-1017
	2 X 18	-0298	-0458	-0618	-1098		2 X 18	-0218	-0378	-0538	-1018
	2 X 19	-0299	-0459	-0619	-1099		2 X 19	-0219	-0379	-0539	-1019
D	2 X 20	-0300	-0460	-0620	-1100		2 X 20	-0220	-0380	-0540	-1020
	2 X 21	-0301	-0461	-0621	-1101		2 X 21	-0221	-0381	-0541	-1021
	2 X 22	-0302	-0462	-0622	-1102		2 X 22	-0222	-0382	-0542	-1022
	2 X 23	-0303	-0463	-0623	-1103		2 X 23	-0223	-0383	-0543	-1023
	2 X 24	-0304	-0464	-0624	-1104		2 X 24	-0224	-0384	-0544	-1024
	2 X 25	-0305	-0465	-0625	-1105		2 X 25	-0225	-0385	-0545	-1025
	2 X 26	-0306	-0466	-0626	-1106		2 X 26	-0226	-0386	-0546	-1026
	2 X 27	-0307	-0467	-0627	-1107		2 X 27	-0227	-0387	-0547	-1027
	2 X 28	-0308	-0468	-0628	-1108		2 X 28	-0228	-0388	-0548	-1028
	2 X 29	-0309	-0469	-0629	-1109		2 X 29	-0229	-0389	-0549	-1029
C	2 X 30	-0310	-0470	-0630	-1110		2 X 30	-0230	-0390	-0550	-1030
	2 X 31	-0311	-0471	-0631	-1111		2 X 31	-0231	-0391	-0551	-1031
	2 X 32	-0312	-0472	-0632	-1112		2 X 32	-0232	-0392	-0552	-1032
	2 X 33	-0313	-0473	-0633	-1113		2 X 33	-0233	-0393	-0553	-1033
	2 X 34	-0314	-0474	-0634	-1114		2 X 34	-0234	-0394	-0554	-1034
	2 X 35	-0315	-0475	-0635	-1115		2 X 35	-0235	-0395	-0555	-1035
	2 X 36	-0316	-0476	-0636	-1116		2 X 36	-0236	-0396	-0556	-1036
	2 X 37	-0317	-0477	-0637	-1117		2 X 37	-0237	-0397	-0557	-1037
	2 X 38	-0318	-0478	-0638	-1118		2 X 38	-0238	-0398	-0558	-1038
B	2 X 39	-0319	-0479	-0639	-1119		2 X 39	-0239	-0399	-0559	-1039
	2 X 40	90122-0320	90122-0480	90122-0640	90122-1120		2 X 40	90122-0240	90122-0400	90122-0560	90122-1040

DIM C (±0.25) ±.008 (6.75) .266

DIM C (±0.25) ±.008 (5.75) .226

DIM D (±0.25) ±.010 (2.90) .114

DIM D (±0.25) ±.010 (2.90) .114

NOTES:  
FOR PLATING VARIATIONS SEE  
ENG.STD. SDES-99000-0003.

UPDATE TOL SYMMETRY EC NO: S2010-0867 DRWNSKANG 2010/04/15 CHYKATSEE 2010/04/27 APPR:MLONG 2010/04/27 M1	QUALITY SYMBOLS	GENERAL TOLERANCES (UNLESS SPECIFIED)	DIMENSION STYLE MM ONLY	SCALE NTS	DESIGN UNITS METRIC	THIRD ANGLE PROJECTION
	▽=0	4 PLACES ±--- ±---	DRAWN BY DB	DATE 16/07/87	TITLE C-GRID III DUAL ROW RIGHT ANGLE HEADER	
	▽=0	3 PLACES ±--- ±---	CHECKED BY ATSEE	DATE 2010/04/27	MOLEX INCORPORATED	
	▽=0	2 PLACES ±--- ±---	APPROVED BY MLONG	DATE 2010/04/27	DOCUMENT NO. SDA-90122	SHEET NO. 5 OF 6
		1 PLACE ±--- ±---	MATERIAL NO. SEE TABLE	THIS DRAWING CONTAINS INFORMATION THAT IS PROPRIETARY TO MOLEX INCORPORATED AND SHOULD NOT BE USED WITHOUT WRITTEN PERMISSION		
		ANGULAR ±---°	DRAFT WHERE APPLICABLE MUST REMAIN WITHIN DIMENSIONS			

	10	9	8	7	6	5	4	3	2	1	
	CIRCUIT SIZE	PLATING TYPE B PART NO.	PLATING TYPE C PART NO.	PLATING TYPE D PART NO.	PLATING TYPE G PART NO.		CIRCUIT SIZE	PLATING TYPE B PART NO.	PLATING TYPE C PART NO.	PLATING TYPE D PART NO.	PLATING TYPE G PART NO.
	2 X 1	90122-0241	90122-0401	90122-0561	90122-1041		2 X 1	90122-0321	90122-0481	90122-0641	90122-1121
	2 X 2	-0242	-0402	-0562	-1042		2 X 2	-0322	-0482	-0642	-1122
	2 X 3	-0243	-0403	-0563	-1043		2 X 3	-0323	-0483	-0643	-1123
	2 X 4	-0244	-0404	-0564	-1044		2 X 4	-0324	-0484	-0644	-1124
	2 X 5	-0245	-0405	-0565	-1045		2 X 5	-0325	-0485	-0645	-1125
	2 X 6	-0246	-0406	-0566	-1046		2 X 6	-0326	-0486	-0646	-1126
	2 X 7	-0247	-0407	-0567	-1047		2 X 7	-0327	-0487	-0647	-1127
	2 X 8	-0248	-0408	-0568	-1048		2 X 8	-0328	-0488	-0648	-1128
	2 X 9	-0249	-0409	-0569	-1049		2 X 9	-0329	-0489	-0649	-1129
	2 X 10	-0250	-0410	-0570	-1050		2 X 10	-0330	-0490	-0650	-1130
	2 X 11	-0251	-0411	-0571	-1051		2 X 11	-0331	-0491	-0651	-1131
	2 X 12	-0252	-0412	-0572	-1052		2 X 12	-0332	-0492	-0652	-1132
	2 X 13	-0253	-0413	-0573	-1053		2 X 13	-0333	-0493	-0653	-1133
	2 X 14	-0254	-0414	-0574	-1054		2 X 14	-0334	-0494	-0654	-1134
	2 X 15	-0255	-0415	-0575	-1055		2 X 15	-0335	-0495	-0655	-1135
	2 X 16	-0256	-0416	-0576	-1056		2 X 16	-0336	-0496	-0656	-1136
	2 X 17	-0257	-0417	-0577	-1057		2 X 17	-0337	-0497	-0657	-1137
	2 X 18	-0258	-0418	-0578	-1058		2 X 18	-0338	-0498	-0658	-1138
	2 X 19	-0259	-0419	-0579	-1059		2 X 19	-0339	-0499	-0659	-1139
	2 X 20	-0260	-0420	-0580	-1060		2 X 20	-0340	-0500	-0660	-1140
	2 X 21	-0261	-0421	-0581	-1061		2 X 21	-0341	-0501	-0661	-1141
	2 X 22	-0262	-0422	-0582	-1062		2 X 22	-0342	-0502	-0662	-1142
	2 X 23	-0263	-0423	-0583	-1063		2 X 23	-0343	-0503	-0663	-1143
	2 X 24	-0264	-0424	-0584	-1064		2 X 24	-0344	-0504	-0664	-1144
	2 X 25	-0265	-0425	-0585	-1065		2 X 25	-0345	-0505	-0665	-1145
	2 X 26	-0266	-0426	-0586	-1066		2 X 26	-0346	-0506	-0666	-1146
	2 X 27	-0267	-0427	-0587	-1067		2 X 27	-0347	-0507	-0667	-1147
	2 X 28	-0268	-0428	-0588	-1068		2 X 28	-0348	-0508	-0668	-1148
	2 X 29	-0269	-0429	-0589	-1069		2 X 29	-0349	-0509	-0669	-1149
	2 X 30	-0270	-0430	-0590	-1070		2 X 30	-0350	-0510	-0670	-1150
	2 X 31	-0271	-0431	-0591	-1071		2 X 31	-0351	-0511	-0671	-1151
	2 X 32	-0272	-0432	-0592	-1072		2 X 32	-0352	-0512	-0672	-1152
	2 X 33	-0273	-0433	-0593	-1073		2 X 33	-0353	-0513	-0673	-1153
	2 X 34	-0274	-0434	-0594	-1074		2 X 34	-0354	-0514	-0674	-1154
	2 X 35	-0275	-0435	-0595	-1075		2 X 35	-0355	-0515	-0675	-1155
	2 X 36	-0276	-0436	-0596	-1076		2 X 36	-0356	-0516	-0676	-1156
	2 X 37	-0277	-0437	-0597	-1077		2 X 37	-0357	-0517	-0677	-1157
	2 X 38	-0278	-0438	-0598	-1078		2 X 38	-0358	-0518	-0678	-1158
	2 X 39	-0279	-0439	-0599	-1079		2 X 39	-0359	-0519	-0679	-1159
	2 X 40	90122-0280	90122-0440	90122-0600	90122-1080		2 X 40	90122-0360	90122-0520	90122-0680	90122-1160

DIM C (+0.25/-0.08) (5.75) .226

DIM C (+0.25/-0.08) (6.75) .266

DIM D (+0.25/-0.10) (4.50) .177

DIM D (+0.25/-0.10) (4.50) .177

NOTES:  
FOR PLATING VARIATIONS SEE  
ENG.STD. SDES-99000-0003.

UPDATE TOL SYMMETRY	2010/04/15	QUALITY SYMBOLS
EC NO: S2010-0867	DRWNSKANG	▽=0
CHKD:ATSEE	2010/04/27	▽=0
APPR:MLONG	2010/04/27	▽=0
REV	DESCRIPTION	
M1		

GENERAL TOLERANCES (UNLESS SPECIFIED)	
mm	INCH
4 PLACES ±---	±---
3 PLACES ±---	±---
2 PLACES ±---	±---
1 PLACE ±---	±---
ANGULAR ±---°	
DRAFT WHERE APPLICABLE MUST REMAIN WITHIN DIMENSIONS	

DIMENSION STYLE	
MM ONLY	
DRAWN BY	DATE
DB	16/07/87
CHECKED BY	DATE
ATSEE	2010/04/27
APPROVED BY	DATE
MLONG	2010/04/27
MATERIAL NO.	SEE TABLE
SIZE	A3

SCALE	NTS	DESIGN UNITS	METRIC	THIRD ANGLE PROJECTION
TITLE				
C-GRID III DUAL ROW RIGHT ANGLE HEADER				
MOLEX INCORPORATED				
DOCUMENT NO.	SDA-90122		SHEET NO. 6 OF 6	
THIS DRAWING CONTAINS INFORMATION THAT IS PROPRIETARY TO MOLEX INCORPORATED AND SHOULD NOT BE USED WITHOUT WRITTEN PERMISSION				