

Customer Information Sheet

DRAWING No.: M80-842XXXX

SHEET 2 OF 2

IF IN DOUBT - ASK

©

NOT TO SCALE

THIRD ANGLE PROJECTION

ALL DIMENSIONS IN mm

ORDER CODE:

M80-842XXXX

TOTAL No. OF WAYS
02-07, 17, 22

FINISH

45 - GOLD
42 - SELECTIVE GOLD / 100% TIN

NOTES:

1. 2-OFF STRAIN RELIEF STRAP M80-0030006 ARE INCLUDED WITH EACH CONNECTOR.

SPECIFICATIONS:

MATERIAL:

MOULDING = GLASS-FILLED POLYAMIDE 46 UL94V-0, BLACK
CONTACTS = PHOSPHOR BRONZE
LATCHES = BERYLLIUM COPPER

FINISH:

CONTACTS:
45 = 0.75µ GOLD
42 = 0.75µ GOLD ON CONTACT AREA, 3.0µ 100% TIN ON TAILS
LATCHES = 1.25µ NICKEL

ELECTRICAL:

CURRENT RATING AT 25°C = 3.0A MAX
CURRENT RATING AT 85°C = 2.2A MAX
WORKING VOLTAGE = 120V AC/DC
VOLTAGE PROOF = 360V AC/DC
CONTACT RESISTANCE (INITIAL) = 20 mΩ MAX
CONTACT RESISTANCE (AFTER CONDITIONING) = 25 mΩ MAX
INSULATION RESISTANCE (INITIAL) = 1,000 MΩ MIN
INSULATION RESISTANCE (AFTER CONDITIONING) = 100 MΩ MIN

MECHANICAL:

DURABILITY = 500 OPERATIONS

ENVIRONMENTAL:

TEMPERATURE RANGE = -55°C TO +125°C

PACKING:

TUBE
FOR COMPLETE SPECIFICATION, SEE COMPONENT SPECIFICATION C005XX (LATEST ISSUE)

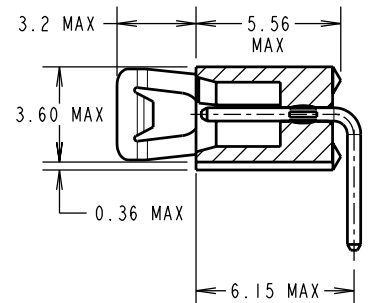
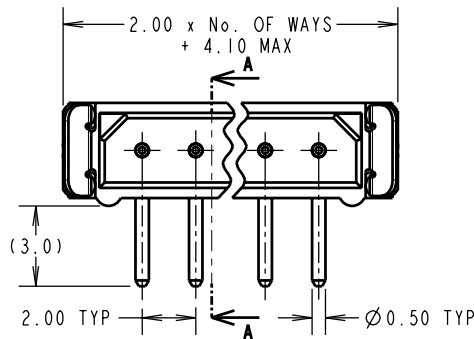

SECTION A-A

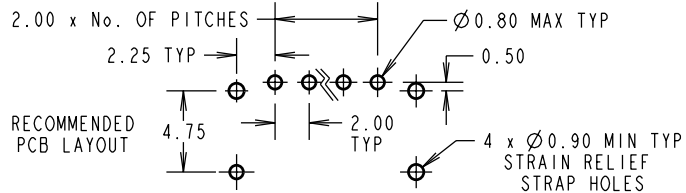
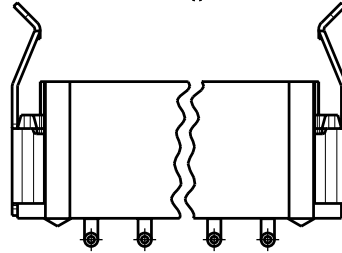

RA	4	03.09.08	10127
NAME	ISS.	DATE	C/NOTE
APPROVED:		R. ADDE	
CHECKED:		M.G. PLESTED	
DRAWN:		W J BOURNE	
CUSTOMER REF.:			
ASSEMBLY DRG:			

HARWIN

HARWIN USA
TEL: 603 893 5376
FAX: 603 893 5396
mis@harwin.com

HARWIN Europe (UK)
TEL: 023 9231 4545
FAX: 023 9231 4590
mis@harwin.co.uk

HARWIN Asia
TEL: +65 6 779 4909
FAX: +65 6 779 3868
mis@harwin.com.sg

THIS DRAWING AND ANY INFORMATION OR DESCRIPTIVE MATTER SET OUT HEREON ARE CONFIDENTIAL AND COPYRIGHT PROPERTY OF THE HARWIN GROUP AND MUST NOT BE DISCLOSED, LOANED, COPIED OR USED FOR MANUFACTURING, TENDERING OR FOR ANY OTHER PURPOSE WITHOUT THEIR WRITTEN PERMISSION.

TOLERANCES

X. = ±1mm
X.X = ±0.25mm
X.XX = ±0.10mm
X.XXX = ±0.01mm
ANGLES = ±5°
UNLESS STATED

MATERIAL:

SEE ABOVE

FINISH:

S/AREA:

mm²

TITLE: DATAMATE 2mm PITCH HORIZONTAL PC TAIL SIL PLUG ASSEMBLY - LATCHED (RoHS)

DRAWING NUMBER:

M80-842XXXX

SHT
2
OF
2