

10 | 9 | 8 | 7 | 6 | 5 | 4 | 3 | 2 | 1

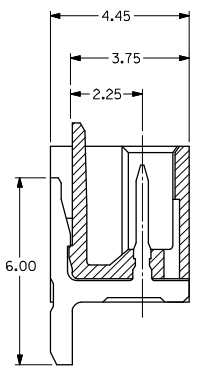

SECTION A-A

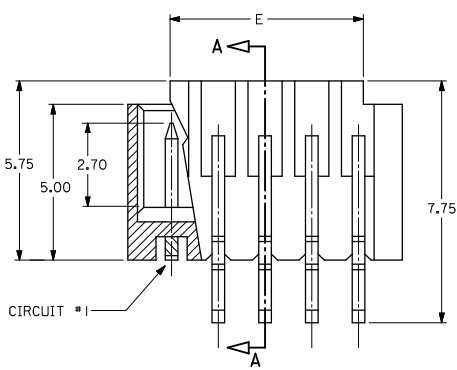
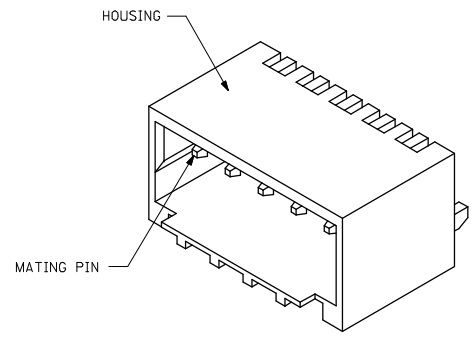
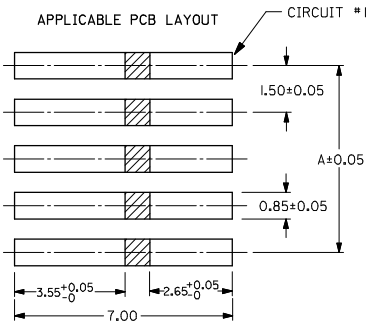
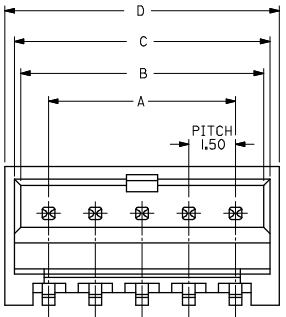
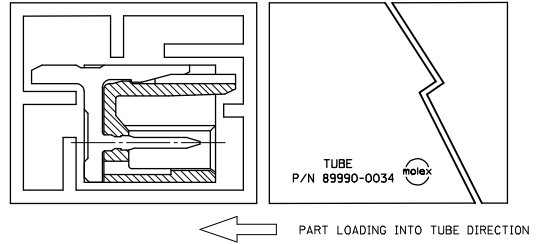

PART LOADING INTO TUBE DIRECTION

- NOTES:
- MATERIALS:  
HOUSING: NYLON, GLASS-FILLED, UL94 V-0,  
COLOR: SEE TABLE  
PINS: BRASS ALLOY, C26000
  - PLATING: 2.54µM MIN. TIN OVER 1.27µM MIN. NICKEL.
  - DRAWING SHOWS PLUG WITH 5 CIRCUITS.
  - HEADER TO BE USED WITH CRIMP HOUSING, P/N 87439 AND CRIMP TERMINAL, P/N 87421
  - PARTS SHALL BE PACKED IN MOISTURE BARRIER BAG.

|   |                    |                               |                                       |                      |  |  |                                |                        |                        |  |
|---|--------------------|-------------------------------|---------------------------------------|----------------------|--|--|--------------------------------|------------------------|------------------------|--|
| ADD TUBE DETAILS<br>ELEC NO: S22008-0476<br>DRWNSKANG 2007/12/14<br>CHYKATSEE 2007/12/18<br>APPR:MLONG 2007/12/18<br>D3 | DESCRIPTION<br>REV | QUALITY SYMBOLS<br>▽=0<br>▽=0 | GENERAL TOLERANCES (UNLESS SPECIFIED) |                      | DIMENSION STYLE<br>MM ONLY   |  | SCALE<br>NTS                   | DESIGN UNITS<br>METRIC | THIRD ANGLE PROJECTION |  |
|   |                    | 4 PLACES ± --- ± ---          | mm INCH                               | DRAWN BY<br>KCLING   | DATE<br>1994/04/08   | TITLE<br>1.50MM PITCH, W-T-B<br>HEADER, R/A, SMT |                                |                        |                        |  |
|   |                    | 3 PLACES ± --- ± ---          | 2 PLACES ± 0.20 ± ---                 | CHECKED BY<br>SKTOH  | DATE<br>1994/04/21   | MOLEX INCORPORATED                               |                                |                        |                        |  |
|   |                    | 1 PLACE ± --- ± ---           | ANGULAR ± 3°                          | APPROVED BY<br>RWONG | DATE<br>1994/04/24   | MATERIAL NO.<br>SEE TABLE                        | DOCUMENT NO.<br>SD-87438-**-31 | SHEET NO.<br>1 OF 3    |                        |  |
| DRAFT WHERE APPLICABLE<br>MUST REMAIN<br>WITHIN DIMENSIONS  |                    |                               | SIZE<br>A3                            |                      | THIS DRAWING CONTAINS INFORMATION THAT IS PROPRIETARY TO MOLEX<br>INCORPORATED AND SHOULD NOT BE USED WITHOUT WRITTEN PERMISSION |  |                                |                        |                        |  |

9 | 8 | 7 | 6 | 5 | 4 | 3 | 2 | 1

10 9 8 7 6 5 4 3 2 1

| CKT SIZE | A     | B     | C     | D     | E     |
|----------|-------|-------|-------|-------|-------|
| 02       | 1.50  | 3.30  | 3.70  | 4.30  | 1.70  |
| 03       | 3.00  | 4.80  | 5.20  | 5.80  | 3.20  |
| 04       | 4.50  | 6.30  | 6.70  | 7.30  | 4.70  |
| 05       | 6.00  | 7.80  | 8.20  | 8.80  | 6.20  |
| 06       | 7.50  | 9.30  | 9.70  | 10.30 | 7.70  |
| 07       | 9.00  | 10.80 | 11.20 | 11.80 | 9.20  |
| 08       | 10.50 | 12.30 | 12.70 | 13.30 | 10.70 |
| 09       | 12.00 | 13.80 | 14.20 | 14.80 | 12.20 |
| 10       | 13.50 | 15.30 | 15.70 | 16.30 | 13.70 |
| 11       | 15.00 | 16.80 | 17.20 | 17.80 | 15.20 |
| 12       | 16.50 | 18.30 | 18.70 | 19.30 | 16.70 |
| 13       | 18.00 | 19.80 | 20.20 | 20.80 | 18.20 |
| 14       | 19.50 | 21.30 | 21.70 | 22.30 | 19.70 |
| 15       | 21.00 | 22.80 | 23.20 | 23.80 | 21.20 |

PART NUMBER ASSIGNMENT

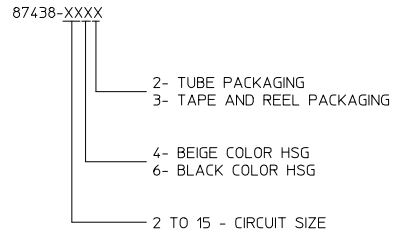

| ADD TUBE DETAILS<br>EEC NO: S2008-0476<br>DRWNSKANG 2007/12/14<br>CHYKATSEE 2007/12/18<br>APPR:MLONG 2007/12/18 | DESCRIPTION<br>REV | QUALITY SYMBOLS | GENERAL TOLERANCES (UNLESS SPECIFIED)   | DIMENSION STYLE<br>MM ONLY | SCALE<br>NTS | DESIGN UNITS<br>METRIC | THIRD ANGLE PROJECTION |       |       |          |       |       |          |        |       |         |       |       |   |   |                                     |                     |
|---|--------------------|-----------------|---|----------------------------|--------------|------------------------|------------------------|-------|-------|----------|-------|-------|----------|--------|-------|---------|-------|-------|---|---|-------------------------------------|---------------------|
|   |                    | ▽=0<br>▽=0      | <table border="1"> <tr><th></th><th>mm</th><th>INCH</th></tr> <tr><td>4 PLACES</td><td>± ---</td><td>± ---</td></tr> <tr><td>3 PLACES</td><td>± ---</td><td>± ---</td></tr> <tr><td>2 PLACES</td><td>± 0.20</td><td>± ---</td></tr> <tr><td>1 PLACE</td><td>± ---</td><td>± ---</td></tr> </table> ANGULAR ± 3° |                            | mm           | INCH                   | 4 PLACES               | ± --- | ± --- | 3 PLACES | ± --- | ± --- | 2 PLACES | ± 0.20 | ± --- | 1 PLACE | ± --- | ± --- | DRAWN BY DATE<br>KCLING 1994/04/08<br>CHECKED BY DATE<br>SKTOH 1994/04/21<br>APPROVED BY DATE<br>RWONG 1994/04/24 | TITLE<br>1.50MM PITCH, W-T-B HEADER, R/A, SMT | MOLEX INCORPORATED<br>SD-87438-**31 | SHEET NO.<br>2 OF 3 |
|   |                    |                 | mm  | INCH                       |              |                        |                        |       |       |          |       |       |          |        |       |         |       |       |   |   |                                     |                     |
|   |                    | 4 PLACES        | ± ---   | ± ---                      |              |                        |                        |       |       |          |       |       |          |        |       |         |       |       |   |   |                                     |                     |
| 3 PLACES  | ± ---              | ± ---           |   |                            |              |                        |                        |       |       |          |       |       |          |        |       |         |       |       |   |   |                                     |                     |
| 2 PLACES  | ± 0.20             | ± ---           |   |                            |              |                        |                        |       |       |          |       |       |          |        |       |         |       |       |   |   |                                     |                     |
| 1 PLACE   | ± ---              | ± ---           |   |                            |              |                        |                        |       |       |          |       |       |          |        |       |         |       |       |   |   |                                     |                     |
| DRAFT WHERE APPLICABLE MUST REMAIN WITHIN DIMENSIONS  |                    | SEE TABLE       | THIS DRAWING CONTAINS INFORMATION THAT IS PROPRIETARY TO MOLEX INCORPORATED AND SHOULD NOT BE USED WITHOUT WRITTEN PERMISSION   |                            |              |                        |                        |       |       |          |       |       |          |        |       |         |       |       |   |   |                                     |                     |
|   |                    | SIZE<br>A3      |   |                            |              |                        |                        |       |       |          |       |       |          |        |       |         |       |       |   |   |                                     |                     |
|   |                    |                 |   |                            |              |                        |                        |       |       |          |       |       |          |        |       |         |       |       |   |   |                                     |                     |

9 8 7 6 5 4 3 2 1

|                |    |       |     |       |       |   |   |   |   |
|----------------|----|-------|-----|-------|-------|---|---|---|---|
| 10             | 9  | 8     | 7   | 6     | 5     | 4 | 3 | 2 | 1 |
| 15             | 44 | 20.20 | 100 | 44.40 | 50.40 |   |   |   |   |
| 11, 12, 13, 14 | 32 | 14.20 | 100 | 32.40 | 38.40 |   |   |   |   |
| 7, 8, 9, 10    | 24 | 11.50 | 100 | 24.40 | 30.40 |   |   |   |   |
| 2, 3, 4, 5, 6  | 16 | 7.50  | 100 | 16.40 | 22.40 |   |   |   |   |
| CIRCUIT SIZE   | A  | B     | N   | G     | T MAX |   |   |   |   |

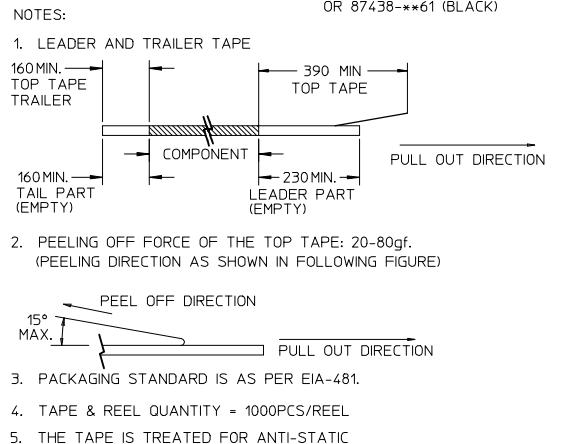
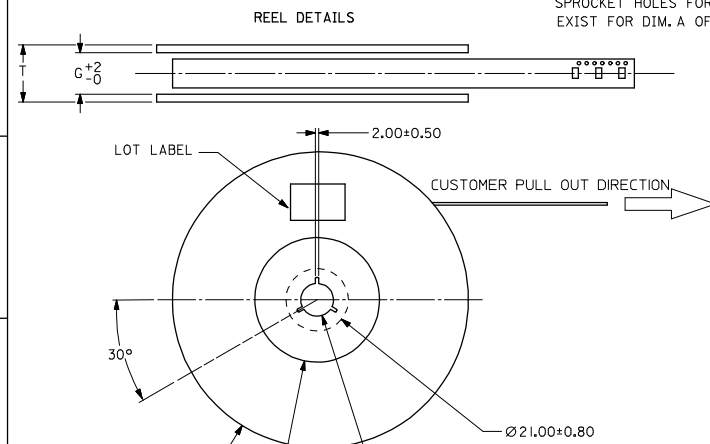
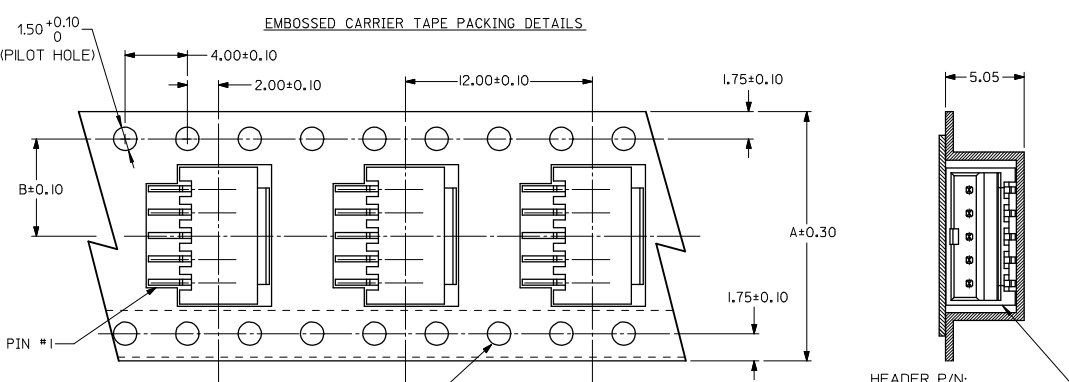

|  |   |  |         |                                      |  |                                |                        |  |
|--|---|--|---------|--------------------------------------|--|--------------------------------|------------------------|--|
| <b>ADD TUBE DETAILS</b><br>ELC NO: S22008-0476<br>DRAWNSKANG 2007/12/14<br>CHYKATSEE 2007/12/18<br>APPR:MLONG 2007/12/18<br>D3 | <b>QUALITY SYMBOLS</b><br>▽=0<br>▽=0<br>▽=0 | <b>GENERAL TOLERANCES (UNLESS SPECIFIED)</b> |         | <b>DIMENSION STYLE</b><br>MM ONLY    | <b>SCALE</b><br>NTS                                  | <b>DESIGN UNITS</b><br>METRIC  | THIRD ANGLE PROJECTION |  |
|  |   | 4 PLACES ± --- ± ---                         | mm INCH | DRAWN BY DATE<br>KCLING 1994/04/08   | <b>TITLE</b><br>1.50MM PITCH, W-T-B HEADER, R/A, SMT |                                |                        |  |
|  |   | 3 PLACES ± --- ± ---                         |         | CHECKED BY DATE<br>SKTOH 1994/04/21  | <b>MOLEX INCORPORATED</b>                            |                                |                        |  |
|  |   | 2 PLACES ± 0.20 ± ---                        |         | APPROVED BY DATE<br>RWONG 1994/04/24 | MATERIAL NO.<br>SEE TABLE                            | DOCUMENT NO.<br>SD-87438-**-31 | SHEET NO.<br>3 OF 3    |  |