

6 5 4 3 2 1

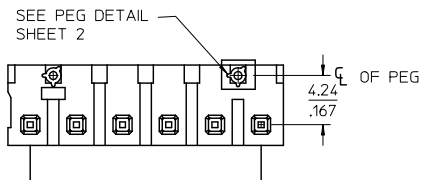
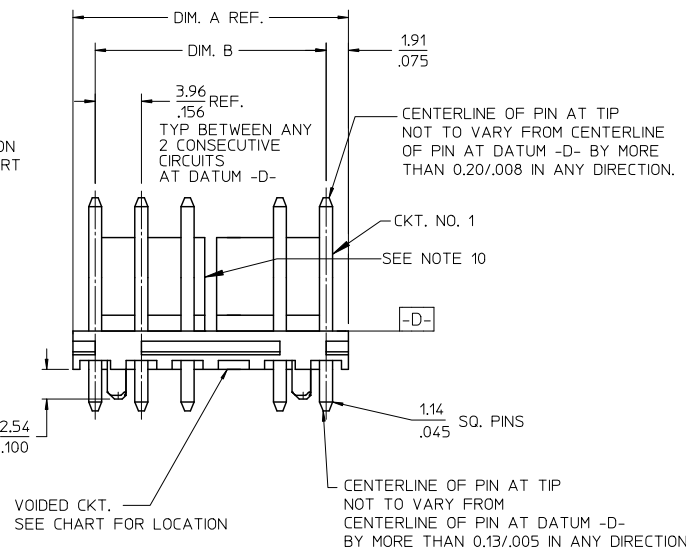
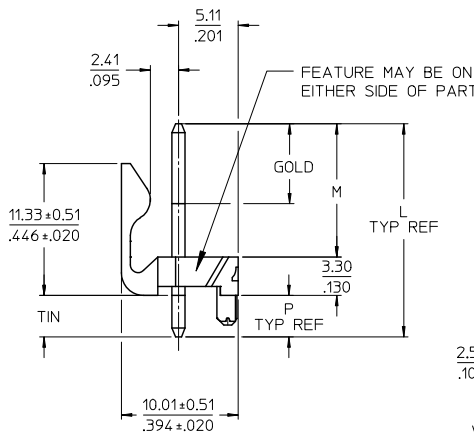

CKTS.	DIM. A	DIM. B	SLOT LOC BETWEEN CKTS
2	7.77 .306	3.96±0.05 .156±.002	NONE
3	11.73 .462	7.92±0.08 .312±.003	NONE
4	15.70 .618	11.89±0.08 .468±.003	NONE
5	19.66 .774	15.85±0.10 .624±.004	NONE
6	23.62 .930	19.81±0.10 .780±.004	3 & 4
7	27.58 1.086	23.77±0.10 .936±.004	4 & 5
8	31.55 1.242	27.74±0.13 1.092±.005	4 & 5
9	35.51 1.398	31.70±0.13 1.248±.005	5 & 6
10	39.47 1.554	35.66±0.13 1.404±.005	5 & 6
11	43.43 1.710	39.62±0.15 1.560±.006	6 & 7
12	47.40 1.866	43.59±0.15 1.716±.006	4 & 5 8 & 9

GEN. DOCS.	3-*	F4
ANNOTATOR	1-2	F5
SOFTWARE	SHT.	REV.

ADD SLOT EC NO: UCP2009-2603 DRAWN: MKIPPER 2009/05/04 CHKD: SSOUSEK 2009/05/04 APPR: FSMITH 2009/05/04 REV: F5	QUALITY SYMBOLS	GENERAL TOLERANCES (UNLESS SPECIFIED)	DIMENSION STYLE	SCALE	DESIGN UNITS	THIRD ANGLE PROJECTION
	▼=0 ▽=0	mm INCH 4 PLACES ± --- ± --- 3 PLACES ± --- ± .010 2 PLACES ± 0.25 ± .015 1 PLACE ± 0.38 ± --- ANGULAR ± 1/2°	MM/IN	2:1	INCH	DRAWN BY: SCHAFFER CHECKED BY: SAMIEC APPROVED BY: MARGULIS DATE: 11-14-03 DATE: 11-14-03 DATE: 11-14-03
		DRAFT WHERE APPLICABLE MUST REMAIN WITHIN DIMENSIONS	SEE CHART	TITLE	KK 156 HEADER ASSEMBLY FRICTION LOCK VERTICAL PEGS	
			SIZE A	MOLEX INCORPORATED		DOCUMENT NO. SD-42491-001

tb_frame_A_P_AM_T
Rev. E 2006/04/15

5 4 3 2 1

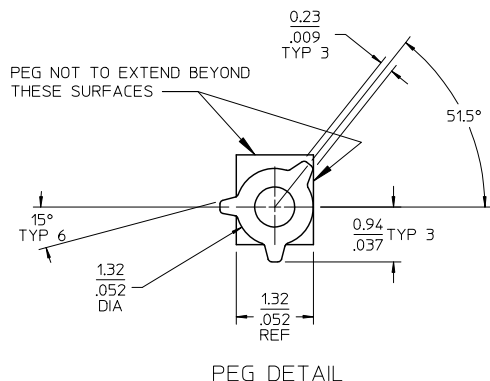

PEG DETAIL

NOTES:

1. MATERIAL: HEADER-POLYESTER, 94V-0, MOLDED NATURAL (WHITE)
PINS: BRASS
2. FINISHES: (102) TIN 0.00508/.000200 MIN. OVER 0.00254/.000100 MIN. COPPER.
(208) SELECT GOLD 0.00038/.000015 MIN. SELECT TIN 0.00254/.000100 MIN. OVER NICKEL
(228) SELECT GOLD 0.00076/.000030 MIN. SELECT TIN 0.00254/.000100 MIN. OVER NICKEL
3. PRODUCT SPECIFICATION: SEE PS-08-50.
4. PACKAGING INFORMATION: SEE CHARTS.
5. SOLDERABILITY: WHEN PARTS ARE SOLDERED AT A TEMPERATURE OF 230°C (446°F) FOR 5 SECONDS, EACH SOLDERED SURFACE SHALL BE A MINIMUM OF 95% COVERED.
6. PIN PUSH OUT FORCE: PRIOR TO SOLDERING = 3 LB MINIMUM FORCE (IN EITHER DIRECTION) SHALL BE REQUIRED TO PUSH THE PIN OUT OF THE HEADER.
7. PARTS ARE STACKABLE END TO END ON (3.96)/.156 CENTERS.
8. FOR PART WITHOUT PEGS SEE DWG. NO. SDA-41791.
9. THIS PART CONFORMS TO CLASS B REQUIREMENTS OF COSMETIC SPECIFICATION PS-45499-002.
10. SLOTS ON BACKWALL ARE BETWEEN CIRCUITS. SEE CHART FOR LOCATION.

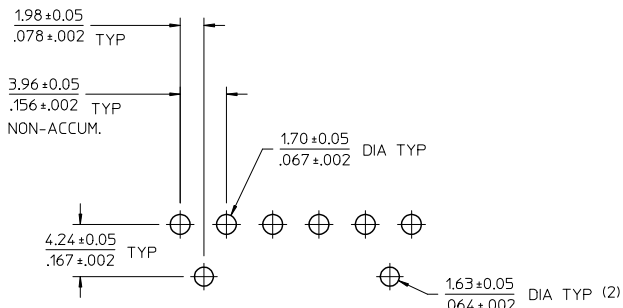

PCB LAYOUT: COMPONENT SIDE

SEE SHEET 1 EC NO: UCP2009-2603 DRAWN: KIPPER CHKD: SOUSEK APPR: F. SMITH 2009/05/04 2009/05/04 2009/05/04	DESCRIPTION REVISIONS 1 2	QUALITY SYMBOLS ▽=0 ▽=0	GENERAL TOLERANCES (UNLESS SPECIFIED)		DIMENSION STYLE MM/IN		SCALE 1:1	DESIGN UNITS INCH	THIRD ANGLE PROJECTION																									
		<table border="1"> <tr> <th></th> <th>mm</th> <th>INCH</th> </tr> <tr> <td>4 PLACES</td> <td>± .005</td> <td>± .0005</td> </tr> <tr> <td>3 PLACES</td> <td>± .005</td> <td>± .0010</td> </tr> <tr> <td>2 PLACES</td> <td>± 0.25</td> <td>± .015</td> </tr> <tr> <td>1 PLACE</td> <td>± 0.38</td> <td>± .015</td> </tr> </table>			mm	INCH	4 PLACES	± .005	± .0005	3 PLACES	± .005	± .0010	2 PLACES	± 0.25	± .015	1 PLACE	± 0.38	± .015	<table border="1"> <tr> <th>DRAWN BY</th> <th>DATE</th> </tr> <tr> <td>SCHAFFER</td> <td>11-14-03</td> </tr> <tr> <th>CHECKED BY</th> <th>DATE</th> </tr> <tr> <td>SAMIEC</td> <td>11-14-03</td> </tr> <tr> <th>APPROVED BY</th> <th>DATE</th> </tr> <tr> <td>MARGULIS</td> <td>11-14-03</td> </tr> </table>		DRAWN BY	DATE	SCHAFFER	11-14-03	CHECKED BY	DATE	SAMIEC	11-14-03	APPROVED BY	DATE	MARGULIS	11-14-03	TITLE KK 156 HEADER ASSEMBLY FRICTION LOCK VERTICAL PEGS	
			mm	INCH																														
		4 PLACES	± .005	± .0005																														
3 PLACES	± .005	± .0010																																
2 PLACES	± 0.25	± .015																																
1 PLACE	± 0.38	± .015																																
DRAWN BY	DATE																																	
SCHAFFER	11-14-03																																	
CHECKED BY	DATE																																	
SAMIEC	11-14-03																																	
APPROVED BY	DATE																																	
MARGULIS	11-14-03																																	
DRAFT WHERE APPLICABLE MUST REMAIN WITHIN DIMENSIONS			MATERIAL NO. SEE CHART		MOLEX INCORPORATED		DOCUMENT NO. SD-42491-001		SHEET NO. 2 OF 2																									

tb_frame_A_P_AM_T
Rev. E 2006/04/15

OPTIONS	Group	A-42491-0002/0018	Group	A-42491-0312/0328	Group	A-42491-0329/0345	Group	
	Header No:	41790-0019/0035	Header No:	41790-0019/0035	Header No:	41790-0019/0035	Header No:	
	Pin No:	2161-94(102)	Pin No:	43294-0209	Pin No:	43294-0210	Pin No:	
	Plating:	102 – TIN	Plating:	208 – 15 GOLD	Plating:	228 – 30 GOLD	Plating:	
	Pin Length L	18.29 / .720	Pin Length L	18.29/. 720	Pin Length L	18.29/. 720	Pin Length L	
	Mating M	11.43 / .450	Mating M	11.43/. 450	Mating M	11.43/. 450	Mating M	
	Gold Loc G	N/A	Gold Loc G	6.86/. 270	Gold Loc G	6.86/. 270	Gold Loc G	
	PC Tail P	3.56 / .140	PC Tail P	3.56/. 140	PC Tail P	3.56/. 140	PC Tail P	
	Tin Loc T	OVERALL	Tin Loc T	4.06/. 160	Tin Loc T	4.06/. 160	Tin Loc T	
	Voided Ckts	NONE	Voided Ckts	NONE	Voided CKts	NONE	Voided Ckts	
Pack Per	PK-42491-001	Pack Per	PK-42491-001	Pack Per	PK-42491-001	Pack Per		
Ckts	Material No	Engineer Number	Material No	Engineer Number	Material No	Engineer Number	Material No	Engineer Number
2	26-64-4020	A-42491-0002	42491-0312	A-42491-0312	42491-0329	A-42491-0329		
3	26-64-4030	A-42491-0003	42491-0313	A-42491-0313	42491-0330	A-42491-0330		
4	26-64-4040	A-42491-0004	42491-0314	A-42491-0314	42491-0331	A-42491-0331		
5	26-64-4050	A-42491-0005	42491-0315	A-42491-0315	42491-0332	A-42491-0332		
6	26-64-4060	A-42491-0006	42491-0316	A-42491-0316	42491-0333	A-42491-0333		
7	26-64-4070	A-42491-0007	42491-0317	A-42491-0317	42491-0334	A-42491-0334		
8	26-64-4080	A-42491-0008	42491-0318	A-42491-0318	42491-0335	A-42491-0335		
9	26-64-4090	A-42491-0009	42491-0319	A-42491-0319	42491-0336	A-42491-0336		
10	26-64-4100	A-42491-0010	42491-0320	A-42491-0320	42491-0337	A-42491-0337		
11	26-64-4110	A-42491-0011	42491-0321	A-42491-0321	42491-0338	A-42491-0338		
12	26-64-4120	A-42491-0012	42491-0322	A-42491-0322	42491-0339	A-42491-0339		

REV: F4	<u>ECR/ECN INFORMATION</u>	<u>TITLE:</u> KK 156 HEADER ASSEMBLY FRICTION LOCK VERTICAL PEGS	<u>SHEET No.</u> - 3 -
	EC NO: UCP2009-0094 DATE: 7/25/2008		
<u>DOCUMENT NUMBER:</u> SD- 42491-001	<u>CREATED / REVISED BY:</u> GAVERRILL	<u>CHECKED BY:</u> MKIPPER	<u>APPROVED BY:</u> FSMITH

OPTIONS	Group	A-42491-0019/0035	Group	A-42491-0036/0052	Group	A-42491-0059/0074	Group	A-42491-0086-0100
	Header No:	41790-0019/0035	Header No:	41790-0019/0035	Header No:	41790-0020/0035	Header No:	41790-0021/0035
	Pin No:	2161-94(501)	Pin No:	2161-94(102)	Pin No:	2161-94(102)	Pin No:	2161-94(102)
	Plating:	501 - GOLD	Plating:	102 - TIN	Plating:	102 - TIN	Plating:	102 - TIN
	Pin Length L	18.29 / .720	Pin Length L	18.29/ .720	Pin Length L	18.29/ .720	Pin Length L	18.29/ .720
	Mating M	11.43 / .450	Mating M	11.43/ .450	Mating M	11.43/ .450	Mating M	11.43/ .450
	Gold Loc G	OVERALL	Gold Loc G	N/A	Gold Loc G	N/A	Gold Loc G	N/A
	PC Tail P	3.56 / .140	PC Tail P	3.56/ .140	PC Tail P	3.56/ .140	PC Tail P	3.56/ .140
	Tin Loc T	N/A	Tin Loc T	OVERALL	Tin Loc T	OVERALL	Tin Loc T	OVERALL
	Voided Ckts	NONE	Voided Ckts	2	Voided CKts	3	Voided Ckts	2, 4
Pack Per	PK-42491-001	Pack Per	PK-42491-001	Pack Per	PK-42491-001	Pack Per	PK-42491-001	
Ckts	Material No	Engineer Number	Material No	Engineer Number	Material No	Engineer Number	Material No	Engineer Number
2	26-65-4020	A-42491-0019						
3	26-65-4030	A-42491-0020	26-62-4035	A-42491-0037	27-62-4032	A-42491-0059		
4	26-65-4040	A-42491-0021	26-62-4045	A-42491-0038	27-62-4042	A-42491-0060		A-42491-0086
5	26-65-4050	A-42491-0022	26-62-4055	A-42491-0039	27-62-4052	A-42491-0061		A-42491-0087
6	26-65-4060	A-42491-0023	26-62-4065	A-42491-0040	27-62-4062	A-42491-0062	27-60-4061	A-42491-0088
7	26-65-4070	A-42491-0024	26-62-4075	A-42491-0041	27-62-4072	A-42491-0063		A-42491-0089
8	26-65-4080	A-42491-0025	26-62-4085	A-42491-0042	27-62-4082	A-42491-0064		A-42491-0090
9	26-65-4090	A-42491-0026	26-62-4095	A-42491-0043	27-62-4092	A-42491-0065		A-42491-0091
10	26-65-4100	A-42491-0027	26-62-4105	A-42491-0044	27-62-4102	A-42491-0066		A-42491-0092
11	26-65-4110	A-42491-0028	26-62-4115	A-42491-0045	27-62-4112	A-42491-0067		A-42491-0093
12	26-65-4120	A-42491-0029	26-62-4125	A-42491-0046	27-62-4122	A-42491-0068		A-42491-0094

REV: F4	ECR/ECN INFORMATION EC NO: UCP2009-0094 DATE: 7/25/2008	TITLE: KK 156 HEADER ASSEMBLY FRICTION LOCK VERTICAL PEGS	SHEET No. - 4 -
DOCUMENT NUMBER: SD- 42491-001	CREATED / REVISED BY: GAVERRILL	CHECKED BY: MKIPPER	APPROVED BY: FSMITH

OPTIONS	Group	A-42491-0172/0188	Group	A-42491-0223/0239	Group	A-42491-0240/0251	Group	A-42491-0252/0265
	Header No:	41790-0019/0035	Header No:	41790-0019/0035	Header No:	41790-0023/0035	Header No:	41790-0022/0035
	Pin No:	2161-36(102)	Pin No:	2161-1(122)	Pin No:	2161-94(102)	Pin No:	2161-94(102)
	Plating:	102 - TIN	Plating:	122 - TIN	Plating:	102 - TIN	Plating:	102 - TIN
	Pin Length L	30.48/ 1.200	Pin Length L	19.05/ .750	Pin Length L	18.29/ .720	Pin Length L	18.29/ .720
	Mating M	13.28/ .523	Mating M	11.43/ .450	Mating M	11.43/ .450	Mating M	11.43/ .450
	Gold Loc G	N/A	Gold Loc G	N/A	Gold Loc G	N/A	Gold Loc G	N/A
	PC Tail P	13.89/ .547	PC Tail P	4.32/ .170	PC Tail P	3.56/ .140	PC Tail P	3.56/ .140
	Tin Loc T	OVERALL	Tin Loc T	OVERALL	Tin Loc T	OVERALL	Tin Loc T	OVERALL
	Voided Ckts	NONE	Voided Ckts	NONE	Voided CKts	7	Voided Ckts	5
Pack Per	PK-42491-003	Pack Per	PK-42491-001	Pack Per	PK-42491-001	Pack Per	PK-42491-001	
Ckts	Material No	Engineer Number	Material No	Engineer Number	Material No	Engineer Number	Material No	Engineer Number
2		A-42491-0172	42491-0223	A-42491-0223				
3		A-42491-0173	42491-0224	A-42491-0224				
4		A-42491-0174	42491-0225	A-42491-0225				
5		A-42491-0175	42491-0226	A-42491-0226			42491-0252	A-42491-0252
6	26-64-4061	A-42491-0176	42491-0227	A-42491-0227			27-62-4068	A-42491-0253
7		A-42491-0177	42491-0228	A-42491-0228	42491-0240	A-42491-0240	42491-0254	A-42491-0254
8		A-42491-0178	42491-0229	A-42491-0229	27-62-4087	A-42491-0241	42491-0255	A-42491-0255
9		A-42491-0179	42491-0230	A-42491-0230	42491-0242	A-42491-0242	42491-0256	A-42491-0256
10		A-42491-0180	42491-0231	A-42491-0231	42491-0243	A-42491-0243	42491-0257	A-42491-0257
11		A-42491-0181	42491-0232	A-42491-0232	42491-0244	A-42491-0244	42491-0258	A-42491-0258
12		A-42491-0182	42491-0233	A-42491-0233	42491-0245	A-42491-0245	42491-0259	A-42491-0259

REV: F4	<u>ECR/ECN INFORMATION</u>	<u>TITLE:</u> KK 156 HEADER ASSEMBLY FRICTION LOCK VERTICAL PEGS	<u>SHEET No.</u> - 5 -
	EC NO: UCP2009-0094 DATE: 7/25/2008		
<u>DOCUMENT NUMBER:</u> SD- 42491-001	<u>CREATED / REVISED BY:</u> GAVERRILL	<u>CHECKED BY:</u> MKIPPER	<u>APPROVED BY:</u> FSMITH

OPTIONS	Group	A-42491-0266/0275	Group	A-42491-0276/0286	Group	A-42491-0287/0299	Group	A-42491-0300/0311
	Header No:	41790-0026/0035	Header No:	41790-0025/0035	Header No:	41790-0024/0035	Header No:	41790-0025/0035
	Pin No:	2161-94(102)	Pin No:	2161-94(102)	Pin No:	2161-94(102)	Pin No:	2161-94(102)
	Plating:	102 - TIN	Plating:	102 - TIN	Plating:	102 - TIN	Plating:	102 - TIN
	Pin Length L	18.29/ .720	Pin Length L	18.29/ .720	Pin Length L	18.29/ .720	Pin Length L	18.29/ .720
	Mating M	11.43 / .450	Mating M	11.43/ .450	Mating M	11.43/ .450	Mating M	11.43/ .450
	Gold Loc G	N/A	Gold Loc G	N/A	Gold Loc G	N/A	Gold Loc G	N/A
	PC Tail P	13.89/ .547	PC Tail P	3.56/ .140	PC Tail P	3.56/ .140	PC Tail P	3.56/ .140
	Tin Loc T	OVERALL	Tin Loc T	OVERALL	Tin Loc T	OVERALL	Tin Loc T	OVERALL
	Voided Ckts	3, 5, 6, 8, 9	Voided Ckts	2, 3, 5, 6, 8	Voided CKts	3, 6	Voided Ckts	2, 5, 7
Pack Per	PK-42491-001	Pack Per	PK-42491-001	Pack Per	PK-42491-001	Pack Per		
Ckts	Material No	Engineer Number	Material No	Engineer Number	Material No	Engineer Number	Material No	Engineer Number
2								
3								
4								
5								
6								
7					42491-0287	A-42491-0287		
8			42491-0276	A-42491-0276	42491-0288	A-42491-0288	42491-0300	A-42491-0300
9	42491-0266	A-42491-0266	42491-0277	A-42491-0277	42491-0289	A-42491-0289	42491-0301	A-42491-0301
10	27-66-4104	A-42491-0267	27-66-4105	A-42491-0278	42491-0290	A-42491-0290	42491-0302	A-42491-0302
11	42491-0268	A-42491-0268	42491-0279	A-42491-0279	42491-0291	A-42491-0291	42491-0303	A-42491-0303
12	42491-0269	A-42491-0269	42491-0280	A-42491-0280	42491-0292	A-42491-0292	42491-0304	A-42491-0304
					42491-0293	A-42491-0293	42491-0305	A-42491-0305

REV: F4	<u>ECR/ECN INFORMATION</u>	<u>TITLE:</u> KK 156 HEADER ASSEMBLY FRICTION LOCK VERTICAL PEGS	<u>SHEET No.</u> - 6 -
	EC NO: UCP2009-0094 DATE: 7/25/2008		
<u>DOCUMENT NUMBER:</u> SD- 42491-001	<u>CREATED / REVISED BY:</u> GAVERRILL	<u>CHECKED BY:</u> MKIPPER	<u>APPROVED BY:</u> FSMITH

OPTIONS	Group	A-42491-0346/0352	Group	A-42491-0353/0357	Group	A-42491-0358/0372	Group	A-42491-0373/0387
	Header No:	41790-0029/0035	Header No:	41790-0031/0035	Header No:	41790-0021/0035	Header No:	41790-0021/0035
	Pin No:	2161-94(102)	Pin No:	2161-94(102)	Pin No:	2161-94(102)	Pin No:	2161-94(102)
	Plating:	102 - TIN	Plating:	102 - TIN	Plating:	102 - TIN	Plating:	102 - TIN
	Pin Length L	18.29/ .720	Pin Length L	18.29/ .720	Pin Length L	18.29/ .720	Pin Length L	18.29/ .720
	Mating M	11.43 / .450	Mating M	11.43/ .450	Mating M	11.43/ .450	Mating M	11.43/ .450
	Gold Loc G	N/A	Gold Loc G	N/A	Gold Loc G	N/A	Gold Loc G	N/A
	PC Tail P	3.56/ .140	PC Tail P	3.56/ .140	PC Tail P	3.56/ .140	PC Tail P	3.56/ .140
	Tin Loc T	OVERALL	Tin Loc T	OVERALL	Tin Loc T	OVERALL	Tin Loc T	OVERALL
	Voided Ckts	2, 4, 6, 8, 10, 12	Voided Ckts	2, 4, 6, 8, 10, 14	Voided Ckts	4	Voided Ckts	3, 4
Pack Per	PK-42491-001	Pack Per	PK-42491-001	Pack Per	PK-42491-001	Pack Per	PK-42491-001	
Ckts	Material No	Engineer Number	Material No	Engineer Number	Material No	Engineer Number	Material No	Engineer Number
2								
3								
4								
5					A-42491-0358		A-42491-0373	
6					50-29-1600 A-42491-0359		A-42491-0374	
7					A-42491-0360	42491-0375	A-42491-0375	
8					A-42491-0361		A-42491-0376	
9					A-42491-0362		A-42491-0377	
10					A-42491-0363		A-42491-0378	
11					A-42491-0364		A-42491-0379	
12	42491-0346	A-42491-0346			A-42491-0365		A-42491-0380	
					A-42491-0366		A-42491-0381	

REV: F4	<u>ECR/ECN INFORMATION</u>	<u>TITLE:</u> KK 156 HEADER ASSEMBLY FRICTION LOCK VERTICAL PEGS	<u>SHEET No.</u> - 7 -
	EC NO: UCP2009-0094 DATE: 7/25/2008		
<u>DOCUMENT NUMBER:</u> SD- 42491-001	<u>CREATED / REVISED BY:</u> GAVERRILL	<u>CHECKED BY:</u> MKIPPER	<u>APPROVED BY:</u> FSMITH

OPTIONS	Group	A-42491-0388
	Header No:	41790-0023
	Pin No:	2161-94(102)
	Plating:	102 – TIN
	Pin Length L	18.29 / .720
	Mating M	11.43 / .450
	Gold Loc G	N/A
	PC Tail P	3.56 / .140
	Tin Loc T	OVERALL
	Voided Ckts	6
	Pack Per	PK-42491-001

Ckts	Material No	Engineer Number
2		
3		
4		
5		
6	42491-0388	A-42491-0388
7		
8		
9		
10		
11		
12		
13		
14		
15		
16		
17		
18		

REV: F4	<u>ECR/ECN INFORMATION</u> EC NO: UCP2009-0094 DATE: 7/25/2008	<u>TITLE:</u> KK 156 HEADER ASSEMBLY FRICTION LOCK VERTICAL PEGS	<u>SHEET No.</u> - 8 -
<u>DOCUMENT NUMBER:</u> SD- 42491-001	<u>CREATED / REVISED BY:</u> GAVERRILL	<u>CHECKED BY:</u> MKIPPER	<u>APPROVED BY:</u> FSMITH