

REVISION R

DO NOT SCALE FROM THIS PRINT

IPT1-1XX-XX-XX-D-RA-XXX

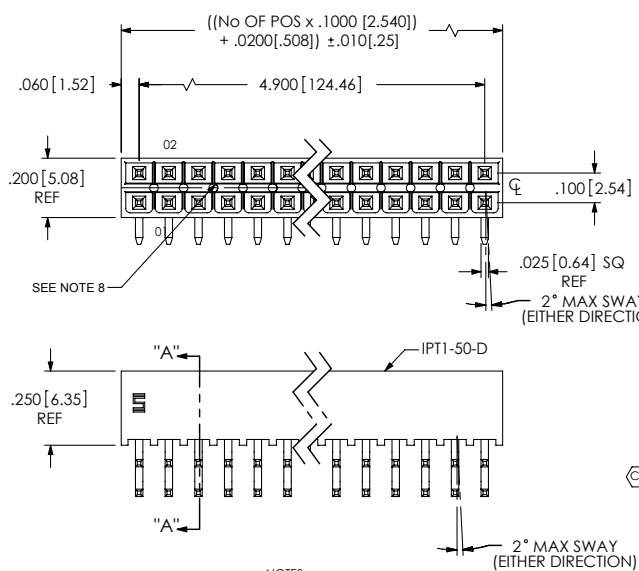

No OF POS PER ROW
 -02 THRU -50

LEAD STYLE
 -01

PLATING SPECIFICATION
 -S: SELECTIVE GOLD, 30 Au / 50 Ni MIN ON CONTACT, MATTE TIN TAIL
 -H: HEAVY GOLD, 30 Au / 50 Ni MIN ON CONTACT, 3 Au / 50 Ni MIN ON TAIL
 -L: LIGHT SELECTIVE GOLD, 10 Au / 50 Ni MIN ON CONTACT, MATTE TIN TAIL
 -SM: SELECTIVE HEAVY GOLD, 30 Au / 50 Ni MIN ON CONTACT, MATTE TIN TAIL

OPTION
 (SEE NOTE 12)
 -POL: POSITION #1 REMOVED (USE IPT1-XX-D-P)
 -FL: FRICTION LOCK (POS -05 THRU -25) (USE IPT1-XX-D-FL-X & T-1S64-XX-X) (FOR -FL-POL OPTION COMBINATION USE IPT1-XX-D-FL-P & T-1S64-XX-X)

TAIL OPTION
 -RA: RIGHT ANGLE

ROW SPECIFICATION
 (SEE NOTE 12)
 -D: DOUBLE (USE IPT1-XX-D)

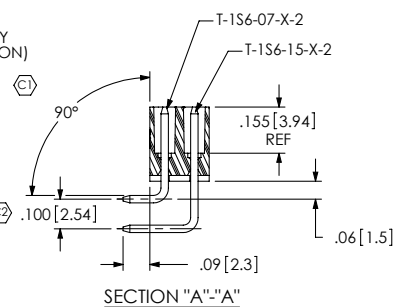

- NOTES:
- ⊕ REPRESENTS A CRITICAL DIMENSION.
 - MAXIMUM ALLOWABLE CUT FLASH: .010[.25].
 - MINIMUM TERMINAL PUSH OUT FORCE: 2 lbs.
 - MAXIMUM VARIATION BETWEEN PIN ROWS: .005[.13].
 - "END WALLS" AFTER CUTTING SHOULD BE .015+/- .003[.38+/- .08].
 - NOTE DELETED.
 - ALL DIMENSIONS TO BE ABOUT CENTERLINE WITHIN +/- .005[.13].
 - PRESENCE OF VOIDS IS OPTIONAL AND PATTERN TO WHICH THEY OCCUR IS VARIABLE.
 - T PLATING OPTION AVAILABLE FOR EXISTING CUSTOMERS ONLY.
 - NOTE DELETED.
 - SAMTEC LOGO INDICATES THE FIRST ROW TO BE FILLED FOR -RA APPLICATION.
 - STANDARD BODIES CAN BE CUT TO POSITION. FOR OPTIONS -POL & -FL, BODIES MUST BE MOLDED TO POSITION.

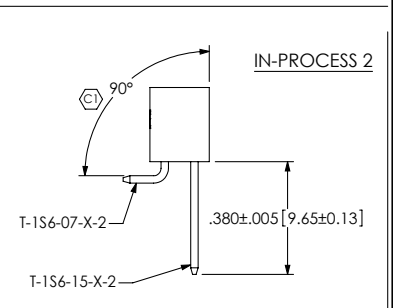
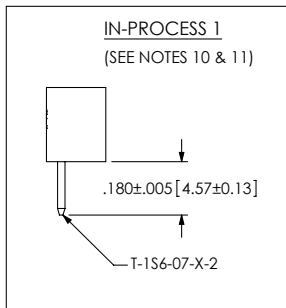
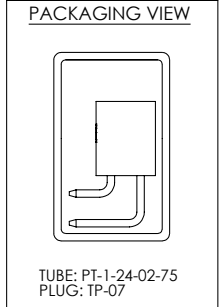
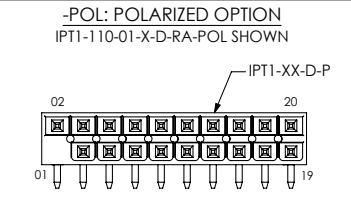
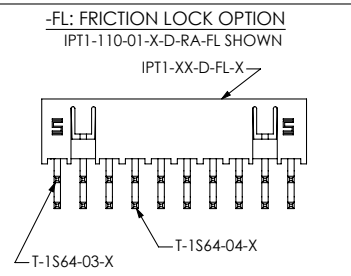

UNLESS OTHERWISE SPECIFIED, DIMENSIONS ARE IN INCHES. TOLERANCES ARE: DECIMALS .XX: ±.01[.3] .XXX: ±.005[.13] .XXXX: ±.0020[.051]	PROPRIETARY NOTE THIS DOCUMENT CONTAINS INFORMATION CONFIDENTIAL AND PROPRIETARY TO SAMTEC, INC. AND SHALL NOT BE REPRODUCED OR TRANSFERRED TO OTHER DOCUMENTS OR DISCLOSED TO OTHERS OR USED FOR ANY PURPOSE OTHER THAN THAT WHICH IT WAS OBTAINED WITHOUT THE EXPRESSED WRITTEN CONSENT OF SAMTEC, INC.		
		520 PARK EAST BLVD., NEW ALBANY, IN 47150 PHONE: 812-944-6733 FAX: 812-948-5047 e-Mail: info@SAMTEC.com code: 55322	
MATERIAL: DO NOT SCALE DRAWING INSULATOR: LCP, UL 94 VO, COLOR: BLACK CONTACT: PHOS BRONZE, 510, 3/4 HARD	SHEET SCALE: 2:1	DESCRIPTION: .100 DOUBLE ROW SHROUDED TERMINAL ASSEMBLY	
DWG. NO. IPT1-1XX-XX-XX-D-RA-XXX		BY: DEAN P 11-05-2002 SHEET 1 OF 1	