

Tous droits strictement réservés. Reproduction ou communication à des tiers interdite sous quelque forme que ce soit sans autorisation écrite du propriétaire. Propriété de c FCI. Droits de reproduction FCI.

All rights strictly reserved. Reproduction or issue to third parties in any form whatever is not permitted without written authority from the proprietor. Property of FCI. Copyright FCI.

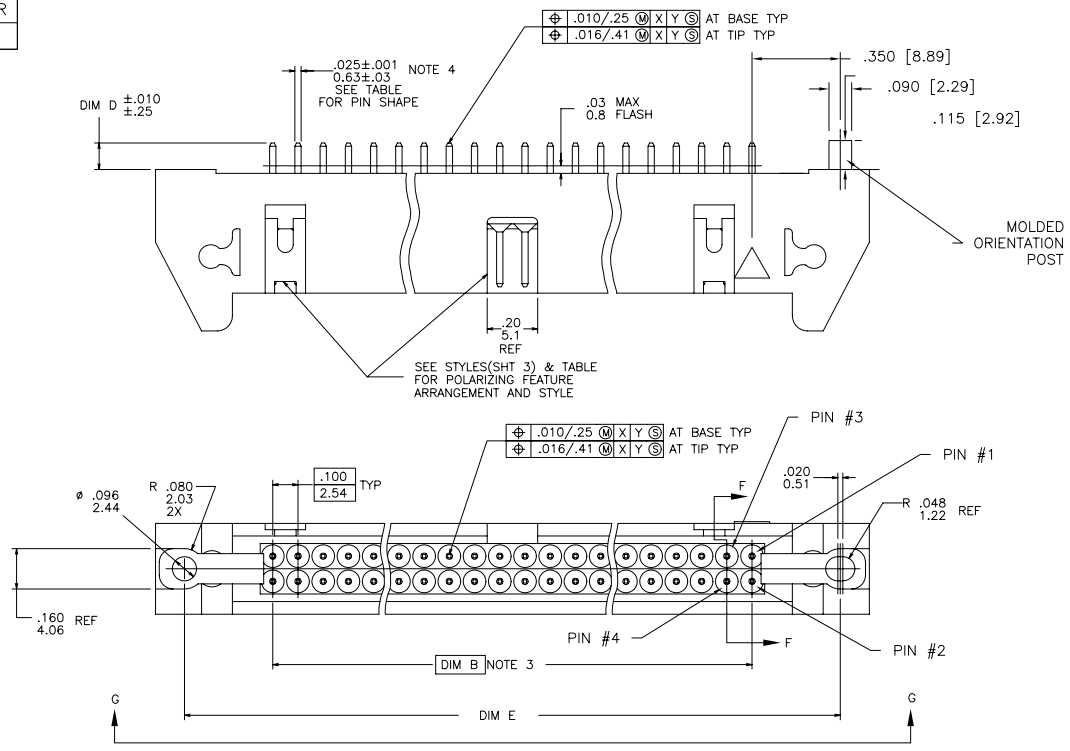

PRODUCT NUMBER
SEE TABLE



mat'l. code		tolerances unless otherwise specified		CUSTOMER COPY	www.fciconnect.com
l tr	ec n no	dr	date	linear	
BA	N08-0073	Bobby S	4/28/08	.xx ±.01/.xx±.3	
BB	N09-0007	R.B	2009/01/12	.xxx ±.005/.xxx±.13	
				angles	INCH/MM
				0° ±2°	scale
				dr M. CORMAN 8/21/90	1:1
				engr M. SMYK 8/21/90	
				chr M. SMYK 8/21/90	
				appd M. SMYK 8/21/90	
sheet	revision			product family QUICKIE	
index	sheet			size dwg no	
				A 65863	
				code NT	
				sheet 1 of 23	

Tous droits strictement réservés. Reproduction ou communication à des tiers interdite sans l'autorisation écrite du propriétaire. Propriété de FCI. Droits de reproduction FCI.



All rights strictly reserved. Reproduction or issue to third parties in any form whatever is not permitted without written authority from the proprietor. Property of FCI. Copyright FCI.

PRODUCT NUMBER
SEE TABLE

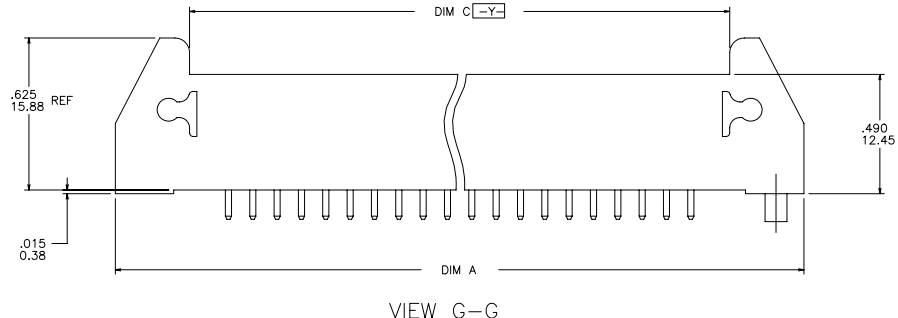
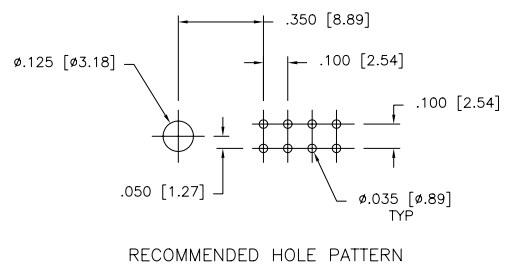
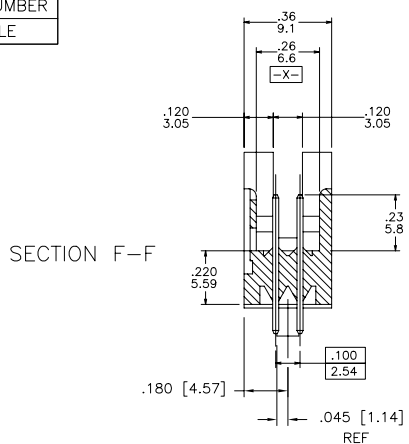

mat'l. code		tolerances unless otherwise specified		CUSTOMER COPY		FCI www.fciconnect.com	
ltr	ecn no	dr	date	linear	projection	title	
BB				.XX ±.01/.XX±.3		HEADER, QUICKIE	
				.XXX ±.005/.XXX±.13		SEA-HORSE, VERTICAL	
				angles	INCH/MM	product family	code
				0° ±2°	←	QUICKIE	NT
				dr	scale	size	sheet
				M. CORNMAN 8/21/90	1:1	dwg no	2 of
				engr		65863	
				M. SMYK 8/21/90			
				chr			
				M. SMYK 8/21/90			
				appo			
				M. SMYK 8/21/90			
sheet	revision					cage code	
index	sheet					Released	

Tous droits strictement réservés. Reproduction ou communication à des tiers interdite sous quelque forme que ce soit sans autorisation écrite du propriétaire. Propriété de FCJ. Droits de reproduction FCJ.

All rights strictly reserved. Reproduction or issue to third parties in any form whatever is not permitted without written authority from the proprietor. Property of FCJ. Copyright FCJ.



PRODUCT NUMBER
SEE TABLE

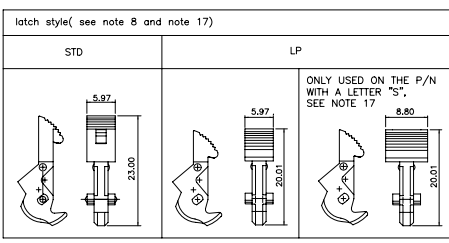
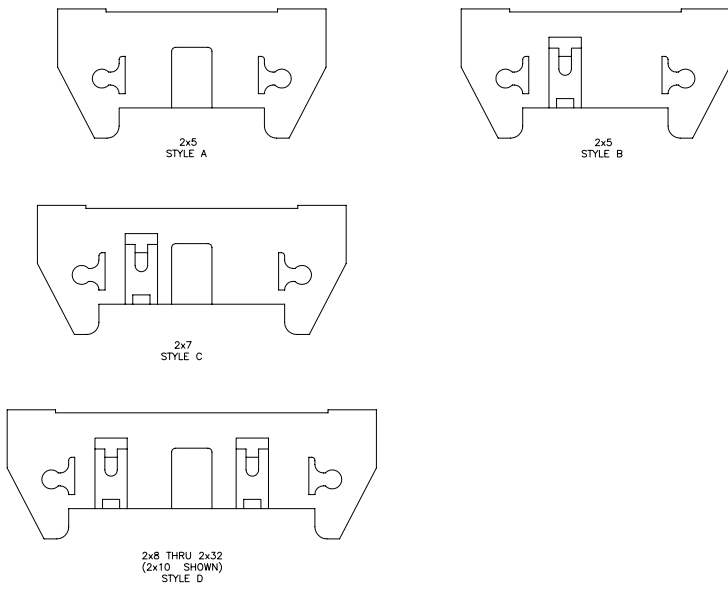

NOTES:

- MOLDING MAT'L : 30% GLASS FILLED POLYESTER, FLAME RETARDANT PER UL-94VE-0, COLOR : BLUE.
- 1" MAX DRAFT PERMISSIBLE ON ALL SURFACES UNLESS OTHERWISE SPECIFIED.
- [B] BASIC DIM SHALL BE LOCATED SYMMETRICAL TO DATUM -Y-.
- PIN MAT'L : 3/4 HARD PHOSPHOR BRONZE ALLOY UNS C-51000.
- PLATING ON LEAD-IN PORTION OF PIN IS MANUFACTURING OPTION.
- RECOMMENDED MOUNTING SCREW SIZE : #2-56 FILLISTER HEAD MACHINE SCREW, 1/4" LONG FOR 1/16" AND 3/32" BOARD, 5/16" LONG FOR 1/8" BOARD.
- 4 LBS/1.8 KG MIN PIN RETENTION IN BOTH DIRECTIONS.
- L.P. LATCHES TO BE USED WITH FEMALE CONNECTOR WITHOUT STRAIN RELIEF. STANDARD LATCHES TO BE USED WITH FEMALE CONNECTOR WITH STRAIN RELIEF.
- A. RETENTION FEATURE AVAILABLE ON CONNECTORS WITH .105/2.67, .120/3.05 OR .150/3.81 TAIL LENGTH. RETENTION P/N INCLUDES THE LETTER "R" AFTER THE EXISTING P/N.
EXAMPLE : 65863-XXX FOR EXISTING P/N
65863-XXXX FOR RETENTION P/N
RETENTION FEATURE LOCATION IS MANUFACTURERS OPTION.
- B. ROUND PINS HAVE 15 LBS/6.8 KG MAX INSERTION AND .25 LB/1 KG MIN RETENTION FORCE WHEN USED IN .035±.003/.89±.08 DIA HOLES AND .062/1.57 THICK PC BOARD.
- C. SQUARE PINS HAVE A 15 LBS/6.8 KG MAX INSERTION AND .5 LB/2 KG MIN RETENTION FORCE WHEN USED IN .040±.003/1.02±.08 DIA HOLES AND .062/1.57 THICK PC BOARD.
- DASH -7XX IS POLARIZED (PIN MISSING).
- 65863-XXXX, P-DESIGNATE ORIENTATION POST.
- ADD "LF" SUFFIX AT THE END OF PART NUMBER FOR LEAD FREE OPTION.
- IF "LF" P/N THE PRODUCT MEETS EUROPEAN UNION DIRECTIVES AND OTHER COUNTRY REGULATION AS DESCRIBED IN GS-22-008.
- THE HOUSING WILL WITHSTAND EXPOSURE TO 260° PEAK TEMPERATURE FOR 15 SECONDS IN A WAVE SOLDER APPLICATION WITH A 1.5mm MINIMUM THICK CIRCUIT BOARD. SEE APPLICATION NOTES/PROCEDURES IF THEY ARE AVAILABLE.
- LEAD FREE PLATING: 100u"-160u"/2.54u-4.06u PURE Sn
- "THIS PRODUCT HAS 100% TIN PLATING IN THE INTERFACE AND HAS NOT BEEN TESTED FOR WHISKER GROWTH IN ALL INTERCONNECT ENVIRONMENTS."
- THE PART NUMBER IN THE DASH NUMBER WITH A LETTER "S" WILL HAVE A SPECIAL SEA HORSE USED.
- PLATING OPTIONS:
MAY BE EITHER GOLD OR GXT PLATED AT MANUFACTURER'S OPTION.

mat'l. code		tolerances unless otherwise specified		CUSTOMER COPY	www.fciconnect.com
l	tr	ec	no	dr	
BB					
linear		.xx ± .01/.xx ± .3			title HEADER, QUICKIE SEA-HORSE, VERTICAL
angles		.xxx ± .005/.xxx ± .13			
dr		.xxx ± .0020/.xxx ± .051			product family QUICKIE size 65863
engr		0° ± 2°			
chr		M. CORMAN 8/21/90		scale 1:1	code NT
appd		M. SMYK 8/21/90			
sheet		M. SMYK 8/21/90		sheet 3 of	
sheet	revision				
index	sheet				

Tous droits strictement réservés. Reproduction ou communication à des tiers interdite sous quelque forme que ce soit sans autorisation écrite du propriétaire. Propriété de c FCI. Droits de reproduction FCI.



All rights strictly reserved. Reproduction or issue to third parties in any form whatever is not permitted without written authority from the proprietor. Property of FCI. Copyright FCI.

PRODUCT NO NOTE 12,13	SIZE	LATCH NOTE 8	PIN SHAPE	DIM A	DIM B	DIM C	DIM D	DIM E	TERMINAL PLATING	STYLE
65863-001	2x5	NO	RND	1.330/33,780	.400/10,160	.720/18,290	.105/ 2,67	1.100/27,940	30?/.76?knote 18) DVER 50?/1.27?Ni	A
-002			SQ				.105/ 2,67		120?200?/3.04?5.08?TIN/LEAD	NOTE 15,16
-003			RND				.150/ 3,81		30?/.76?knote 18) DVER 50?/1.27?Ni	
-004			SQ				.150/ 3,81		120?200?/3.04?5.08?TIN/LEAD	NOTE 15,16
-005			SQ				.675/17,15		30?/.76?knote 18) DVER 50?/1.27?Ni	
-006	2x5		SQ	1.330/33,780	.400/10,160	.720/18,290	.675/17,15	1.100/27,940	120?200?/3.04?5.08?TIN/LEAD	NOTE 15,16
-007	2x7		RND	1.530/38,860	.600/15,240	.920/23,370	.105/ 2,67	1.300/33,020	30?/.76?knote 18) DVER 50?/1.27?Ni	C
-008			SQ				.105/ 2,67		120?200?/3.04?5.08?TIN/LEAD	NOTE 15,16
-009			RND				.150/ 3,81		30?/.76?knote 18) DVER 50?/1.27?Ni	
-010			SQ				.150/ 3,81		120?200?/3.04?5.08?TIN/LEAD	NOTE 15,16
-011			SQ				.675/17,15		30?/.76?knote 18) DVER 50?/1.27?Ni	
-012	2x7		SQ	1.530/38,860	.600/15,240	.920/23,370	.675/17,15	1.300/33,020	120?200?/3.04?5.08?TIN/LEAD	NOTE 15,16
-013	2x8		RND	1.630/41,400	.700/17,780	1.020/25,910	.105/ 2,67	1.400/35,560	30?/.76?knote 18) DVER 50?/1.27?Ni	D
-014			SQ				.105/ 2,67		120?200?/3.04?5.08?TIN/LEAD	NOTE 15,16
-015			RND				.150/ 3,81		30?/.76?knote 18) DVER 50?/1.27?Ni	
-016			SQ				.150/ 3,81		120?200?/3.04?5.08?TIN/LEAD	NOTE 15,16
-017			SQ				.675/17,15		30?/.76?knote 18) DVER 50?/1.27?Ni	
-018	2x8		SQ	1.630/41,400	.700/17,780	1.020/25,910	.675/17,15	1.400/35,560	120?200?/3.04?5.08?TIN/LEAD	NOTE 15,16
-019	2x10		RND	1.830/46,480	.900/22,860	1.220/30,990	.105/ 2,67	1.600/40,640	30?/.76?knote 18) DVER 50?/1.27?Ni	
-020			SQ				.105/ 2,67		120?200?/3.04?5.08?TIN/LEAD	NOTE 15,16
-021			RND				.150/ 3,81		30?/.76?knote 18) DVER 50?/1.27?Ni	
-022			SQ				.150/ 3,81		120?200?/3.04?5.08?TIN/LEAD	NOTE 15,16
-023			SQ				.675/17,15		30?/.76?knote 18) DVER 50?/1.27?Ni	
-024	2x10		SQ	1.830/46,480	.900/22,860	1.220/30,990	.675/17,15	1.600/40,640	120?200?/3.04?5.08?TIN/LEAD	NOTE 15,16
-025	2x13		RND	2.130/54,100	1.200/30,480	1.520/38,610	.105/ 2,67	1.900/48,260	30?/.76?knote 18) DVER 50?/1.27?Ni	
-026			SQ				.105/ 2,67		120?200?/3.04?5.08?TIN/LEAD	NOTE 15,16
-027			RND				.150/ 3,81		30?/.76?knote 18) DVER 50?/1.27?Ni	
-028			SQ				.150/ 3,81		120?200?/3.04?5.08?TIN/LEAD	NOTE 15,16
-029			SQ				.675/17,15		30?/.76?knote 18) DVER 50?/1.27?Ni	
-030	2x13		SQ	2.130/54,100	1.200/30,480	1.520/38,610	.675/17,15	1.900/48,260	120?200?/3.04?5.08?TIN/LEAD	NOTE 15,16
-032	2x17		RND	2.530/64,260	1.600/40,640	1.920/48,770	.105/ 2,67	2.300/58,420	30?/.76?knote 18) DVER 50?/1.27?Ni	
-032			SQ				.105/ 2,67		120?200?/3.04?5.08?TIN/LEAD	NOTE 15,16
-033			RND				.150/ 3,81		30?/.76?knote 18) DVER 50?/1.27?Ni	
-034			SQ				.150/ 3,81		120?200?/3.04?5.08?TIN/LEAD	NOTE 15,16
-035			SQ				.675/17,15		30?/.76?knote 18) DVER 50?/1.27?Ni	
65863-036	2x17	NO	SQ	2.530/64,260	1.600/40,640	1.920/48,770	.675/17,15	2.300/58,420	120?200?/3.04?5.08?TIN/LEAD	NOTE 15,16

mat'l. code		tolerances unless otherwise specified		CUSTOMER COPY		www.fciconnect.com	
l	tr	ec	no	dr	date	linear	projection
BB							
						title HEADER, QUICKIE SEA-HORSE, VERTICAL	
						product family QUICKIE	
						size dwg no 65863	
						code NT	
						sheet 4 of	
sheet index	revision sheet						

Tous droits strictement réservés. Reproduction ou communication à des tiers interdite sous quelque forme que ce soit sans autorisation écrite du propriétaire. Property of FCI. Droits de reproduction FCI.



All rights strictly reserved. Reproduction or issue to third parties in any form whatever is not permitted without written authority from the proprietor. Property of FCI. Copyright FCI.

PRODUCT NO NOTE 12,13	SIZE	LATCH NOTE 8	PIN SHAPE	DIM A	DIM B	DIM C	DIM D	DIM E	TERMINAL PLATING	STYLE
65863-037	2x20	NO	RND	2.830/71,880	1.900/48,260	2.220/56,390	.105/ 2,67	2.600/66,040	30?/.76?knote 18) DVER 50?/1.27?Ni	D
-038			SQ				.105/ 2,67		120?200?/3.04?5.08?TIN/LEAD	NOTE 15,16
-039			RND				.150/ 3,81		30?/.76?knote 18) DVER 50?/1.27?Ni	
-040			SQ				.150/ 3,81		120?200?/3.04?5.08?TIN/LEAD	NOTE 15,16
-041			SQ				.675/17,15		30?/.76?knote 18) DVER 50?/1.27?Ni	
-042	2x20		SQ	2.830/71,880	1.900/48,260	2.220/56,390	.675/17,15	2.600/66,040	120?200?/3.04?5.08?TIN/LEAD	NOTE 15,16
-043	2x25		RND	3.330/84,580	2.400/60,960	2.720/69,090	.105/ 2,67	3.100/78,740	30?/.76?knote 18) DVER 50?/1.27?Ni	
-044			SQ				.105/ 2,67		120?200?/3.04?5.08?TIN/LEAD	NOTE 15,16
-045			RND				.150/ 3,81		30?/.76?knote 18) DVER 50?/1.27?Ni	
-046			SQ				.150/ 3,81		120?200?/3.04?5.08?TIN/LEAD	NOTE 15,16
-047			SQ				.675/17,15		30?/.76?knote 18) DVER 50?/1.27?Ni	
-048	2x25	NO	SQ	3.330/84,580	2.400/60,960	2.720/69,090	.675/17,15	3.100/78,740	120?200?/3.04?5.08?TIN/LEAD	NOTE 15,16
-049	2x5	STD	RND	1.330/33,780	.400/10,160	.720/18,290	.105/ 2,67	1.100/27,940	30?/.76?knote 18) DVER 50?/1.27?Ni	A
-050			SQ				.105/ 2,67		120?200?/3.04?5.08?TIN/LEAD	NOTE 15,16
-051			RND				.150/ 3,81		30?/.76?knote 18) DVER 50?/1.27?Ni	
-052			SQ				.150/ 3,81		120?200?/3.04?5.08?TIN/LEAD	NOTE 15,16
-053			SQ				.675/17,15		30?/.76?knote 18) DVER 50?/1.27?Ni	
-054	2x5		SQ	1.330/33,780	.400/10,160	.720/18,290	.675/17,15	1.100/27,940	120?200?/3.04?5.08?TIN/LEAD	NOTE 15,16
-055	2x7		RND	1.530/38,860	.600/15,240	.920/23,370	.105/ 2,67	1.300/33,020	30?/.76?knote 18) DVER 50?/1.27?Ni	C
-056			SQ				.105/ 2,67		120?200?/3.04?5.08?TIN/LEAD	NOTE 15,16
-057			RND				.150/ 3,81		30?/.76?knote 18) DVER 50?/1.27?Ni	
-058			SQ				.150/ 3,81		120?200?/3.04?5.08?TIN/LEAD	NOTE 15,16
-059			SQ				.675/17,15		30?/.76?knote 18) DVER 50?/1.27?Ni	
-060	2x7		SQ	1.530/38,860	.600/15,240	.920/23,370	.675/17,15	1.300/33,020	120?200?/3.04?5.08?TIN/LEAD	NOTE 15,16
-061	2x8		RND	1.630/41,400	.700/17,780	1.020/25,910	.105/ 2,67	1.400/35,560	30?/.76?knote 18) DVER 50?/1.27?Ni	D
-062			SQ				.105/ 2,67		120?200?/3.04?5.08?TIN/LEAD	NOTE 15,16
-063			RND				.150/ 3,81		30?/.76?knote 18) DVER 50?/1.27?Ni	
-064			SQ				.150/ 3,81		120?200?/3.04?5.08?TIN/LEAD	NOTE 15,16
-065			SQ				.675/17,15		30?/.76?knote 18) DVER 50?/1.27?Ni	
-066	2x8		SQ	1.630/41,400	.700/17,780	1.020/25,910	.675/17,15	1.400/35,560	120?200?/3.04?5.08?TIN/LEAD	NOTE 15,16
-067	2x10		RND	1.830/46,480	.900/22,860	1.220/30,990	.105/ 2,67	1.600/40,640	30?/.76?knote 18) DVER 50?/1.27?Ni	
-068			SQ				.105/ 2,67		120?200?/3.04?5.08?TIN/LEAD	NOTE 15,16
-069			RND				.150/ 3,81		30?/.76?knote 18) DVER 50?/1.27?Ni	
-070			SQ				.150/ 3,81		120?200?/3.04?5.08?TIN/LEAD	NOTE 15,16
-071			SQ				.675/17,15		30?/.76?knote 18) DVER 50?/1.27?Ni	
65863-072	2x10	STD	SQ	1.830/46,480	.900/22,860	1.220/30,990	.675/17,15	1.600/40,640	120?200?/3.04?5.08?TIN/LEAD	NOTE 15,16

mat'l. code		tolerances unless otherwise specified		CUSTOMER COPY		www.fciconnect.com	
ltr	ecn no	dr	date	linear	projection	title	
BB						HEADER, QUICKIE	
				angles	0° ±Z	SEA-HORSE, VERTICAL	
				dr	M. CORNMAN	8/21/90	product family
				enrg	M. SMYK	8/21/90	QUICKIE
				chr	M. SMYK	8/21/90	code
				appd	M. SMYK	8/21/90	NT
sheet	revision						size
index	sheet						dwg no
							65863
							scale
							1:1
							code
							Released

1 | 2

3

4

ACAD

PDM: Rev:BB

STATUS: Released

Printed: Apr 12, 201

Tous droits strictement réservés. Reproduction ou communication à des tiers interdite sous quelque forme que ce soit sans autorisation écrite du propriétaire. Property of FCI. Droits de reproduction FCI.



All rights strictly reserved. Reproduction or issue to third parties in any form whatever is not permitted without written authority from the proprietor. Property of FCI. Copyright FCI.

PRODUCT NO NOTES 12,13	SIZE	LATCH NOTE 8	PIN SHAPE	DIM A	DIM B	DIM C	DIM D	DIM E	TERMINAL PLATING	STYLE
65863-073	2x13	STD	RND	2.130/54,100	1.200/30,480	1.520/38,610	.105/ 2,67	1.900/48,260	30**/.76*(note 18) DVER 50**/1.27*NI	D
-074			SQ				.105/ 2,67		120?200?/3.04?5.08?TIN/LEAD	NOTE 15,16
-075			RND				.150/ 3,81		30**/.76*(note 18) DVER 50**/1.27*NI	
-076			SQ				.150/ 3,81		120?200?/3.04?5.08?TIN/LEAD	NOTE 15,16
-077			SQ				.675/17,15		30**/.76*(note 18) DVER 50**/1.27*NI	
-078	2x13		SQ	2.130/54,100	1.200/30,480	1.520/38,610	.675/17,15	1.900/48,260	120?200?/3.04?5.08?TIN/LEAD	NOTE 15,16
-079	2x17		RND	2.530/64,260	1.600/40,640	1.920/48,770	.105/ 2,67	2.300/58,420	30**/.76*(note 18) DVER 50**/1.27*NI	
-080			SQ				.105/ 2,67		120?200?/3.04?5.08?TIN/LEAD	NOTE 15,16
-081			RND				.150/ 3,81		30**/.76*(note 18) DVER 50**/1.27*NI	
-082			SQ				.150/ 3,81		120?200?/3.04?5.08?TIN/LEAD	NOTE 15,16
-083			SQ				.675/17,15		30**/.76*(note 18) DVER 50**/1.27*NI	
-084	2x17		SQ	2.530/64,260	1.600/40,640	1.920/48,770	.675/17,15	2.300/58,420	120?200?/3.04?5.08?TIN/LEAD	NOTE 15,16
-085	2x20		RND	2.830/71,880	1.900/48,260	2.220/56,390	.105/ 2,67	2.600/66,040	30**/.76*(note 18) DVER 50**/1.27*NI	
-086			SQ				.105/ 2,67		120?200?/3.04?5.08?TIN/LEAD	NOTE 15,16
-087			RND				.150/ 3,81		30**/.76*(note 18) DVER 50**/1.27*NI	
-088			SQ				.150/ 3,81		120?200?/3.04?5.08?TIN/LEAD	NOTE 15,16
-089			SQ				.675/17,15		30**/.76*(note 18) DVER 50**/1.27*NI	
-090	2x20		SQ	2.830/71,880	1.900/48,260	2.220/56,390	.675/17,15	2.600/66,040	120?200?/3.04?5.08?TIN/LEAD	NOTE 15,16
-091	2x25		RND	3.330/84,580	2.400/60,960	2.720/69,090	.105/ 2,67	3.100/78,740	30**/.76*(note 18) DVER 50**/1.27*NI	
-092			SQ				.105/ 2,67		120?200?/3.04?5.08?TIN/LEAD	NOTE 15,16
-093			RND				.150/ 3,81		30**/.76*(note 18) DVER 50**/1.27*NI	
-094			SQ				.150/ 3,81		120?200?/3.04?5.08?TIN/LEAD	NOTE 15,16
-095			SQ				.675/17,15		30**/.76*(note 18) DVER 50**/1.27*NI	
-096	2x25	STD	SQ	3.330/84,580	2.400/60,960	2.720/69,090	.675/17,15	3.100/78,740	120?200?/3.04?5.08?TIN/LEAD	NOTE 15,16
-097	2x30	NO	RND	3.830/97,280	2.900/73,660	3.220/81,790	.105/ 2,67	3.600/91,440	30**/.76*(note 18) DVER 50**/1.27*NI	
-098			SQ				.105/ 2,67		120?200?/3.04?5.08?TIN/LEAD	NOTE 15,16
-099			RND				.150/ 3,81		30**/.76*(note 18) DVER 50**/1.27*NI	
-100			SQ				.150/ 3,81		120?200?/3.04?5.08?TIN/LEAD	NOTE 15,16
-101			SQ				.675/17,15		30**/.76*(note 18) DVER 50**/1.27*NI	
-102		NO	SQ				.675/17,15		120?200?/3.04?5.08?TIN/LEAD	NOTE 15,16
-103		STD	RND				.105/ 2,67		30**/.76*(note 18) DVER 50**/1.27*NI	
-104			SQ				.105/ 2,67		120?200?/3.04?5.08?TIN/LEAD	NOTE 15,16
-105			RND				.150/ 3,81		30**/.76*(note 18) DVER 50**/1.27*NI	
-106			SQ				.150/ 3,81		120?200?/3.04?5.08?TIN/LEAD	NOTE 15,16
-107			SQ				.675/17,15		30**/.76*(note 18) DVER 50**/1.27*NI	
65863-108	2x30	STD	SQ	3.830/97,280	2.900/73,660	3.220/81,790	.675/17,15	3.600/91,440	120?200?/3.04?5.08?TIN/LEAD	NOTE 15,16

mat'l. code		tolerances unless otherwise specified		CUSTOMER COPY		www.fciconnect.com	
ltr	ecn no	dr	date	linear	$.xx \pm .01 / .xx \pm .3$ $.xxx \pm .005 / .xxx \pm .13$ $.xxx \pm .0020 / .xxx \pm .051$	projection	title
BB				angles	0° ± Z°		HEADER, QUICKIE SEA-HORSE, VERTICAL
				dr	M. CORNMAN 8/21/90	INCH/MM	product family QUICKIE code NT
				enrg	M. SMYK 8/21/90	scale	size dwg no 65863 sheet 6 of
				chr	M. SMYK 8/21/90	1:1	
				appd	M. SMYK 8/21/90		
sheet index	revision sheet						

Tous droits strictement réservés. Reproduction ou communication à des tiers interdite sous quelque forme que ce soit sans autorisation écrite du propriétaire. Property of FCJ. Droits de reproduction FCJ.



All rights strictly reserved. Reproduction or issue to third parties in any form whatever is not permitted without written authority from the proprietor. Property of FCJ. Copyright FCJ.

PRODUCT NO NOTE 12,13	SIZE	LATCH NOTE 8	PIN SHAPE	DIM A	DIM B	DIM C	DIM D	DIM E	TERMINAL PLATING	STYLE
65863-109	2x5	NO	SQ	1.330/33,780	.400/10,160	.720/18,290	.105/ 2,67	1.100/27,940	30?/.76?note 18? OVER 50?/1.27?Ni	A
-110	2x7			1.530/38,860	.600/15,240	.920/23,370		1.300/33,020		C
-111	2x8			1.630/41,400	.700/17,780	1.020/25,910		1.400/35,560		D
-112	2x10			1.830/46,480	.900/22,860	1.220/30,990		1.600/40,640		
-113	2x13			2.130/54,100	1.200/30,480	1.520/38,610		1.900/48,260		
-114	2x17			2.530/64,260	1.600/40,640	1.920/48,770		2.300/58,420		
-115	2x20			2.830/71,880	1.900/48,260	2.220/56,390		2.600/66,040		
-116	2x25			3.330/84,580	2.400/60,960	2.720/69,090		3.100/78,740		
-117	2x30	NO		3.830/97,280	2.900/73,660	3.220/81,790		3.600/91,440		D
-118	2x5	STD		1.330/33,780	.400/10,160	.720/18,290		1.100/27,940		A
-119	2x7			1.530/38,860	.600/15,240	.920/23,370		1.300/33,020		C
-120	2x8			1.630/41,400	.700/17,780	1.020/25,910		1.400/35,560		D
-121	2x10			1.830/46,480	.900/22,860	1.220/30,990		1.600/40,640		
-122	2x13			2.130/54,100	1.200/30,480	1.520/38,610		1.900/48,260		
-123	2x17			2.530/64,260	1.600/40,640	1.920/48,770		2.300/58,420		
-124	2x20			2.830/71,880	1.900/48,260	2.220/56,390		2.600/66,040		
-125	2x25			3.330/84,580	2.400/60,960	2.720/69,090		3.100/78,740		
-126	2x30	STD		3.830/97,280	2.900/73,660	3.220/81,790	.105/ 2,67	3.600/91,440		
-127	2x20	NO		2.830/71,880	1.900/48,260	2.220/56,390	.150/ 3,81	2.600/66,040		
-128	2x20	STD	SQ	2.830/71,880	1.900/48,260	2.220/56,390		2.600/66,040	30?/.76?note 18? OVER 50?/1.27?Ni	D
-129	2x5	NO	RND	1.330/33,780	.400/10,160	.720/18,290		1.100/27,940	30?/.76u GXT/GOLD FLASH	A
-130	2x7			1.530/38,860	.600/15,240	.920/23,370		1.300/33,020		C
-131	2x8			1.630/41,400	.700/17,780	1.020/25,910		1.400/35,560		D
-132	2x10			1.830/46,480	.900/22,860	1.220/30,990		1.600/40,640		
-133	2x13			2.130/54,100	1.200/30,480	1.520/38,610		1.900/48,260		
-134	2x17			2.530/64,260	1.600/40,640	1.920/48,770		2.300/58,420		
-135	2x20			2.830/71,880	1.900/48,260	2.220/56,390		2.600/66,040		
-136	2x25			3.330/84,580	2.400/60,960	2.720/69,090		3.100/78,740		
-137	2x30	NO		3.830/97,280	2.900/73,660	3.220/81,790		3.600/91,440		D
-138	2x5	STD		1.330/33,780	.400/10,160	.720/18,290		1.100/27,940		A
-139	2x7			1.530/38,860	.600/15,240	.920/23,370		1.300/33,020		C
-140	2x8			1.630/41,400	.700/17,780	1.020/25,910		1.400/35,560		D
-141	2x10			1.830/46,480	.900/22,860	1.220/30,990		1.600/40,640		
-142	2x13			2.130/54,100	1.200/30,480	1.520/38,610		1.900/48,260		
-143	2x17			2.530/64,260	1.600/40,640	1.920/48,770		2.300/58,420		
65863-144	2x20	STD	RND	2.830/71,880	1.900/48,260	2.220/56,390	.150/ 3,81	2.600/66,040	30?/.76u GXT/GOLD FLASH	D

mat'l. code		tolerances unless otherwise specified		CUSTOMER COPY		FCJ www.fcjconnect.com	
ltr	ecn no	dr	date	linear	projection	title	
BB						HEADER, QUICKIE	
				angles	0° ±Z	SEA-HORSE, VERTICAL	
				dr	M. CORNMAN 8/21/90	product family	QUICKIE
				enrg	M. SMYK 8/21/90	size	dwg no
				chr	M. SMYK 8/21/90	65863	
				appd	M. SMYK 8/21/90	code	NT
sheet	revision				scale	1:1	sheet
index	sheet						7 of

1 | 2

3

4

ACAD

PDM: Rev:BB

STATUS Released

Printed: Apr 12, 201

Tous droits strictement réservés. Reproduction ou communication à des tiers interdite sous quelque forme que ce soit sans autorisation écrite du propriétaire. Property of FCJ. Droits de reproduction FCJ.



All rights strictly reserved. Reproduction or issue to third parties in any form whatever is not permitted without written authority from the proprietor. Property of FCJ. Copyright FCJ.

PRODUCT NO NOTE 12.13	SIZE	LATCH NOTE 8	PIN SHAPE	DIM A	DIM B	DIM C	DIM D	DIM E	TERMINAL PLATING	STYLE
65863-145	2x25	STD	RND	3.330/84,580	2.400/60,960	2.720/69,090	.150/ 3,81	3.100/78,740	301/.761GXT/GOLD FLASH	D
-146	2x30	STD	RND	3.830/97,280	2.900/73,660	3.220/81,790	.150/ 3,81	3.600/91,440	301/.761GXT/GOLD FLASH	D
-147	2x5	NO	SQ	1.330/33,780	.400/10,160	.720/18,290	.675/17,15	1.100/27,940	151/.381MIN (note 18) OVER 501/1.27u Ni	A
-148	2x7			1.530/38,860	.600/15,240	.920/23,370		1.300/33,020		C
-149	2x8			1.630/41,400	.700/17,780	1.020/25,910		1.400/35,560		D
-150	2x10			1.830/46,480	.900/22,860	1.220/30,990		1.600/40,640		
-151	2x13			2.130/54,100	1.200/30,480	1.520/38,610		1.900/48,260		
-152	2x17			2.530/64,260	1.600/40,640	1.920/48,770		2.300/58,420		
-153	2x20			2.830/71,880	1.900/48,260	2.220/56,390		2.600/66,040		
-154	2x25			3.330/84,580	2.400/60,960	2.720/69,090		3.100/78,740		
-155	2x30	NO		3.830/97,280	2.900/73,660	3.220/81,790		3.600/91,440		D
-156	2x5	STD		1.330/33,780	.400/10,160	.720/18,290		1.100/27,940		A
-157	2x7			1.530/38,860	.600/15,240	.920/23,370		1.300/33,020		C
-158	2x8			1.630/41,400	.700/17,780	1.020/25,910		1.400/35,560		D
-159	2x10			1.830/46,480	.900/22,860	1.220/30,990		1.600/40,640		
-160	2x13			2.130/54,100	1.200/30,480	1.520/38,610		1.900/48,260		
-161	2x17			2.530/64,260	1.600/40,640	1.920/48,770		2.300/58,420		
-162	2x20			2.830/71,880	1.900/48,260	2.220/56,390		2.600/66,040		
-163	2x25			3.330/84,580	2.400/60,960	2.720/69,090		3.100/78,740		
-164	2x30	STD	SQ	3.830/97,280	2.900/73,660	3.220/81,790	.675/17,15	3.600/91,440	151/.381MIN (note 18) OVER 501/1.27u Ni	D
-165	2x5	LP	RND	1.330/33,780	.400/10,160	.720/18,290	.105/ 2,67	1.100/27,940	301/.761(note 18) OVER 501/1.27Ni	A
-166			SQ				.105/ 2,67		12012001/3.0415.08?TIN/LEAD	NOTE 15,16
-167			RND				.150/ 3,81		301/.761(note 18) OVER 501/1.27Ni	NOTE 15,16
-168			SQ				.150/ 3,81		12012001/3.0415.08?TIN/LEAD	NOTE 15,16
-169			SQ				.675/17,15		301/.761(note 18) OVER 501/1.27Ni	NOTE 15,16
-170	2x5		SQ	1.330/33,780	.400/10,160	.720/18,290	.675/17,15	1.100/27,940	12012001/3.0415.08?TIN/LEAD	NOTE 15,16
-171	2x7		RND	1.530/38,860	.600/15,240	.920/23,370	.105/ 2,67	1.300/33,020	301/.761(note 18) OVER 501/1.27Ni	C
-172			SQ				.105/ 2,67		12012001/3.0415.08?TIN/LEAD	NOTE 15,16
-173			RND				.150/ 3,81		301/.761(note 18) OVER 501/1.27Ni	NOTE 15,16
-174			SQ				.150/ 3,81		12012001/3.0415.08?TIN/LEAD	NOTE 15,16
-175			SQ				.675/17,15		301/.761(note 18) OVER 501/1.27Ni	NOTE 15,16
-176	2x7		SQ	1.530/38,860	.600/15,240	.920/23,370	.675/17,15	1.300/33,020	12012001/3.0415.08?TIN/LEAD	NOTE 15,16
-177	2x8		RND	1.630/41,400	.700/17,780	1.020/25,910	.105/ 2,67	1.400/35,560	301/.761(note 18) OVER 501/1.27Ni	C
-178	2x8		SQ	1.630/41,400	.700/17,780	1.020/25,910	.105/ 2,67	1.400/35,560	12012001/3.0415.08?TIN/LEAD	NOTE 15,16
-179	2x8		RND	1.630/41,400	.700/17,780	1.020/25,910	.150/ 3,81	1.400/35,560	301/.761(note 18) OVER 501/1.27Ni	D
65863-180	2x8	LP	SQ	1.630/41,400	.700/17,780	1.020/25,910	.150/ 3,81	1.400/35,560	12012001/3.0415.08?TIN/LEAD	NOTE 15,16

mat'l. code		tolerances unless otherwise specified		CUSTOMER COPY		FCJ www.fcjconnect.com	
ltr	ecn no	dr	date	linear	projection	title	
BB						HEADER, QUICKIE	
				angles	0° ±Z	SEA-HORSE, VERTICAL	
				dr	M. CORNMAN 8/21/90	product family	QUICKIE
				enrg	M. SMYK 8/21/90	size	dwg no
				chr	M. SMYK 8/21/90	scale	65863
				appd	M. SMYK 8/21/90	code	NT
sheet	revision					code	8 of
index	sheet					status	Released

1 | 2

ACAD

PDM: Rev:BB

STATUS: Released

Printed: Apr 12, 2011

Tous droits strictement réservés. Reproduction ou communication à des tiers interdite sous quelque forme que ce soit sans autorisation écrite du Propriétaire de c FCI. Droits de reproduction FCI.



All rights strictly reserved. Reproduction or issue to third parties in any form whatever is not permitted without written authority from the proprietor. Property of FCI. Copyright FCI.

PRODUCT NO NOTE 12,13	SIZE	LATCH NOTE 8	PIN SHAPE	DIM A	DIM B	DIM C	DIM D	DIM E	TERMINAL PLATING	STYLE
65863-181	2x8	LP	SQ	1.630/41,400	.700/17,780	1.020/25,910	.675/17,15	1.400/35,560	30 ¹ /.76 ⁷ (note 18) DVER 50 ² /.127 ⁷ NI	D
-182	2x8		SQ	1.630/41,400	.700/17,780	1.020/25,910	.675/17,15	1.400/35,560	120 ² 200 ⁷ /3.0475.08 ⁷ TIN/LEAD	NOTE 15,16
-183	2x10		RND	1.830/46,480	.900/22,860	1.220/30,990	.105/ 2,67	1.600/40,640	30 ¹ /.76 ⁷ (note 18) DVER 50 ² /.127 ⁷ NI	
-184			SQ				.105/ 2,67		120 ² 200 ⁷ /3.0475.08 ⁷ TIN/LEAD	NOTE 15,16
-185			RND				.150/ 3,81		30 ¹ /.76 ⁷ (note 18) DVER 50 ² /.127 ⁷ NI	
-186			SQ				.150/ 3,81		120 ² 200 ⁷ /3.0475.08 ⁷ TIN/LEAD	NOTE 15,16
-187			SQ				.675/17,15		30 ¹ /.76 ⁷ (note 18) DVER 50 ² /.127 ⁷ NI	
-188	2x10		SQ	1.830/46,480	.900/22,860	1.220/30,990	.675/17,15	1.600/40,640	120 ² 200 ⁷ /3.0475.08 ⁷ TIN/LEAD	NOTE 15,16
-189	2x13		RND	2.130/54,100	1.200/30,480	1.520/38,610	.105/ 2,67	1.900/48,260	30 ¹ /.76 ⁷ (note 18) DVER 50 ² /.127 ⁷ NI	
-190			SQ				.105/ 2,67		120 ² 200 ⁷ /3.0475.08 ⁷ TIN/LEAD	NOTE 15,16
-191			RND				.150/ 3,81		30 ¹ /.76 ⁷ (note 18) DVER 50 ² /.127 ⁷ NI	
-192			SQ				.150/ 3,81		120 ² 200 ⁷ /3.0475.08 ⁷ TIN/LEAD	NOTE 15,16
-193			SQ				.675/17,15		30 ¹ /.76 ⁷ (note 18) DVER 50 ² /.127 ⁷ NI	
-194	2x13		SQ	2.130/54,100	1.200/30,480	1.520/38,610	.675/17,15	1.900/48,260	120 ² 200 ⁷ /3.0475.08 ⁷ TIN/LEAD	NOTE 15,16
-195	2x17		RND	2.530/64,260	1.600/40,640	1.920/48,770	.105/ 2,67	2.300/58,420	30 ¹ /.76 ⁷ (note 18) DVER 50 ² /.127 ⁷ NI	
-196			SQ				.105/ 2,67		120 ² 200 ⁷ /3.0475.08 ⁷ TIN/LEAD	NOTE 15,16
-197			RND				.150/ 3,81		30 ¹ /.76 ⁷ (note 18) DVER 50 ² /.127 ⁷ NI	
-198			SQ				.150/ 3,81		120 ² 200 ⁷ /3.0475.08 ⁷ TIN/LEAD	NOTE 15,16
-199			SQ				.675/17,15		30 ¹ /.76 ⁷ (note 18) DVER 50 ² /.127 ⁷ NI	
-200	2x17		SQ	2.530/64,260	1.600/40,640	1.920/48,770	.675/17,15	2.300/58,420	120 ² 200 ⁷ /3.0475.08 ⁷ TIN/LEAD	NOTE 15,16
-201	2x20		RND	2.830/71,880	1.900/48,260	2.220/56,390	.105/ 2,67	2.600/66,040	30 ¹ /.76 ⁷ (note 18) DVER 50 ² /.127 ⁷ NI	
-202			SQ				.105/ 2,67		120 ² 200 ⁷ /3.0475.08 ⁷ TIN/LEAD	NOTE 15,16
-203			RND				.150/ 3,81		30 ¹ /.76 ⁷ (note 18) DVER 50 ² /.127 ⁷ NI	
-204			SQ				.150/ 3,81		120 ² 200 ⁷ /3.0475.08 ⁷ TIN/LEAD	NOTE 15,16
-205			SQ				.675/17,15		30 ¹ /.76 ⁷ (note 18) DVER 50 ² /.127 ⁷ NI	
-206	2x20		SQ	2.830/71,880	1.900/48,260	2.220/56,390	.675/17,15	2.600/66,040	120 ² 200 ⁷ /3.0475.08 ⁷ TIN/LEAD	NOTE 15,16
-207	2x25		RND	3.330/84,580	2.400/60,960	2.720/69,090	.105/ 2,67	3.100/78,740	30 ¹ /.76 ⁷ (note 18) DVER 50 ² /.127 ⁷ NI	
-208			SQ				.105/ 2,67		120 ² 200 ⁷ /3.0475.08 ⁷ TIN/LEAD	NOTE 15,16
-209			RND				.150/ 3,81		30 ¹ /.76 ⁷ (note 18) DVER 50 ² /.127 ⁷ NI	
-210			SQ				.150/ 3,81		120 ² 200 ⁷ /3.0475.08 ⁷ TIN/LEAD	NOTE 15,16
-211			SQ				.675/17,15		30 ¹ /.76 ⁷ (note 18) DVER 50 ² /.127 ⁷ NI	
-212	2x25		SQ	3.330/84,580	2.400/60,960	2.720/69,090	.675/17,15	3.100/78,740	120 ² 200 ⁷ /3.0475.08 ⁷ TIN/LEAD	NOTE 15,16
-213	2x30		RND	3.830/97,280	2.900/73,660	3.220/81,790	.105/ 2,67	3.600/91,440	30 ¹ /.76 ⁷ (note 18) DVER 50 ² /.127 ⁷ NI	
-214	2x30		SQ	3.830/97,280	2.900/73,660	3.220/81,790	.105/ 2,67	3.600/91,440	120 ² 200 ⁷ /3.0475.08 ⁷ TIN/LEAD	NOTE 15,16
-215	2x30		RND	3.830/97,280	2.900/73,660	3.220/81,790	.150/ 3,81	3.600/91,440	30 ¹ /.76 ⁷ (note 18) DVER 50 ² /.127 ⁷ NI	
65863-216	2x30	LP	SQ	3.830/97,280	2.900/73,660	3.220/81,790	.150/ 3,81	3.600/91,440	120 ² 200 ⁷ /3.0475.08 ⁷ TIN/LEAD	NOTE 15,16

mat'l. code		tolerances unless otherwise specified		CUSTOMER COPY		www.fciconnect.com	
ltr	ecn no	dr	date	linear	.xx ±.01/xx±.3	projection	title
BB					.xxx ±.005/xxx±.13		HEADER, QUICKIE
				angles	.xxx ±.0020/xxx±.051		SEA-HORSE, VERTICAL
				dr	0° ±Z	INCH/MM	product family
				enrg	M. CORNMAN 8/21/90	1:1	QUICKIE
				chr	M. SMYK 8/21/90	scale	size
				appd	M. SMYK 8/21/90	1:1	dwg no
sheet	revision						code
index	sheet						NT
							sheet
							9 of

1 | 2

ACAD

PDM: Rev:BB

STATUS: Released

Printed: Apr 12, 201

Tous droits strictement réservés. Reproduction ou communication à des tiers interdite sous quelque forme que ce soit sans autorisation écrite du propriétaire de c. FCJ. Droits de reproduction FCJ.



All rights strictly reserved. Reproduction or issue to third parties in any form whatever is not permitted without written authority from the proprietor. Property of FCJ. Copyright FCJ.

PRODUCT NO NOTES 12,13	SIZE	LATCH NOTE 8	PIN SHAPE	DIM A	DIM B	DIM C	DIM D	DIM E	TERMINAL PLATING	STYLE
65863-217	2x30	LP	SQ	3.830/97,280	2.900/73,660	3.220/81,790	.675/17,15	3.600/91,440	301?/.76?note 18? DVER 501?/127?NI	D
-218	2x30			3.830/97,280	2.900/73,660	3.220/81,790	.675/17,15	3.600/91,440	120?200?/3.04?5.08?TIN/LEAD	D
-219	2x5			1.330/33,780	.400/10,160	.720/18,290	.105/ 2,67	1.100/27,940	301?/.76?note 18? DVER 501?/127?NI	A
-220	2x7			1.530/38,860	.600/15,240	.920/23,370		1.300/33,020		C
-221	2x8			1.630/41,400	.700/17,780	1.020/25,910		1.400/35,560		D
-222	2x10			1.830/46,480	.900/22,860	1.220/30,990		1.600/40,640		
-223	2x13			2.130/54,100	1.200/30,480	1.520/38,610		1.900/48,260		
-224	2x17			2.530/64,260	1.600/40,640	1.920/48,770		2.300/58,420		
-225	2x20			2.830/71,880	1.900/48,260	2.220/56,390		2.600/66,040		
-226	2x25			3.330/84,580	2.400/60,960	2.720/69,090		3.100/78,740		
-227	2x30			3.830/97,280	2.900/73,660	3.220/81,790	.105/ 2,67	3.600/91,440		
-228	2x20		SQ	1.900/48,260	1.900/48,260	2.220/56,390	.150/ 3,81	2.600/66,040	301?/.76?note 18? DVER 501?/127?NI	D
-229	2x5		RND	1.330/33,780	.400/10,160	.720/18,290		1.100/27,940	301?/.76?GXT/GOLD FLASH	A
-230	2x7			1.530/38,860	.600/15,240	.920/23,370		1.300/33,020		C
-231	2x8			1.630/41,400	.700/17,780	1.020/25,910		1.400/35,560		D
-232	2x10			1.830/46,480	.900/22,860	1.220/30,990		1.600/40,640		
-233	2x13			2.130/54,100	1.200/30,480	1.520/38,610		1.900/48,260		
-234	2x17			2.530/64,260	1.600/40,640	1.920/48,770		2.300/58,420		
-235	2x20			2.830/71,880	1.900/48,260	2.220/56,390		2.600/66,040		
-236	2x25			3.330/84,580	2.400/60,960	2.720/69,090		3.100/78,740		
-237	2x30		RND	3.830/97,280	2.900/73,660	3.220/81,790	.150/ 3,81	3.600/91,440	301?/.76? GXT/GOLD FLASH	D
-238	2x5		SQ	1.330/33,780	.400/10,160	.720/18,290	.675/17,15	1.100/27,940	151?/38?MIN (note 18) DVER 501?/127?NI	A
-239	2x7			1.530/38,860	.600/15,240	.920/23,370		1.300/33,020		C
-240	2x8			1.630/41,400	.700/17,780	1.020/25,910		1.400/35,560		D
-241	2x10			1.830/46,480	.900/22,860	1.220/30,990		1.600/40,640		
-242	2x13			2.130/54,100	1.200/30,480	1.520/38,610		1.900/48,260		
-243	2x17			2.530/64,260	1.600/40,640	1.920/48,770		2.300/58,420		
-244	2x20			2.830/71,880	1.900/48,260	2.220/56,390		2.600/66,040		
-245	2x25			3.330/84,580	2.400/60,960	2.720/69,090		3.100/78,740		
-246	2x30	LP	SQ	3.830/97,280	2.900/73,660	3.220/81,790	.675/17,15	3.600/91,440	151?/38?MIN (note 18) DVER 501?/127?NI	D
-247	2x5	NO	RND	1.330/33,780	.400/10,160	.720/18,290	.105/ 2,67	1.100/27,940	301?/.76?GXT/GOLD FLASH	A
-248	2x7			1.530/38,860	.600/15,240	.920/23,370		1.300/33,020		C
-249	2x8			1.630/41,400	.700/17,780	1.020/25,910		1.400/35,560		D
-250	2x10			1.830/46,480	.900/22,860	1.220/30,990		1.600/40,640		D
-251	2x13			2.130/54,100	1.200/30,480	1.520/38,610		1.900/48,260		D
65863-252	2x17	NO	RND	2.530/64,260	1.600/40,640	1.920/48,770	.105/ 2,67	2.300/58,420	301?/.76?GXT/GOLD FLASH	D

NOTE 15,16

mat'l. code		tolerances unless otherwise specified		CUSTOMER COPY		www.fcjconnect.com	
ltr	ecn no	dr	date	linear	projection	title	
BB						HEADER, QUICKIE	
				angles	0° ±Z	SEA-HORSE, VERTICAL	
				dr	M. CORNMAN 8/21/90	product family	QUICKIE
				enrg	M. SMYK 8/21/90	size	dwg no
				chr	M. SMYK 8/21/90	65863	
				appd	M. SMYK 8/21/90	scale	1:1
sheet	revision						
index	sheet						

ACAD PDM: Rev:BB STATUS: Released Printed: Apr 12, 201

Tous droits strictement réservés. Reproduction ou communication à des fins interdite sous quelque forme que ce soit sans autorisation écrite du propriétaire de c FCI. Droits de reproduction FCI.



All rights strictly reserved. Reproduction or issue to third parties in any form whatever is not permitted without written authority from the proprietor. Property of FCI. Copyright FCI.

PRODUCT NO NOTE 12,13	SIZE	LATCH NOTE 8	PIN SHAPE	DIM A	DIM B	DIM C	DIM D	DIM E	TERMINAL PLATING	STYLE
65863-253	2x20	NO	RND	2.830/71,880	1.900/48,260	2.220/56,390	.105/ 2,67	2.600/66,040	301/.761GXT/GOLD FLASH	D
-254	2x25		RND	3.330/84,580	2.400/60,960	2.720/69,090	.105/ 2,67	3.100/78,740		D
-255	2x30		RND	3.830/97,280	2.900/73,660	3.220/81,790	.105/ 2,67	3.600/91,440		D
-256	2x5		SQ	1.330/33,780	.400/10,160	.720/18,290	.675/17,15	1.100/27,940		A
-257	2x7			1.530/38,860	.600/15,240	.920/23,370		1.300/33,020		C
-258	2x8			1.630/41,400	.700/17,780	1.020/25,910		1.400/35,560		D
-259	2x10			1.830/46,480	.900/22,860	1.220/30,990		1.600/40,640		
-260	2x13			2.130/54,100	1.200/30,480	1.520/38,610		1.900/48,260		
-261	2x17			2.530/64,260	1.600/40,640	1.920/48,770		2.300/58,420		
-262	2x20			2.830/71,880	1.900/48,260	2.220/56,390		2.600/66,040		
-263	2x25			3.330/84,580	2.400/60,960	2.720/69,090		3.100/78,740		
-264	2x30	NO	SQ	3.830/97,280	2.900/73,660	3.220/81,790	.675/17,15	3.600/91,440		D
-265	2x5	STD	RND	1.330/33,780	.400/10,160	.720/18,290	.105/ 2,67	1.100/27,940		A
-266	2x7			1.530/38,860	.600/15,240	.920/23,370		1.300/33,020		C
-267	2x8			1.630/41,400	.700/17,780	1.020/25,910		1.400/35,560		D
-268	2x10			1.830/46,480	.900/22,860	1.220/30,990		1.600/40,640		
-269	2x13			2.130/54,100	1.200/30,480	1.520/38,610		1.900/48,260		
-270	2x17			2.530/64,260	1.600/40,640	1.920/48,770		2.300/58,420		
-271	2x20			2.830/71,880	1.900/48,260	2.220/56,390		2.600/66,040		
-272	2x25			3.330/84,580	2.400/60,960	2.720/69,090		3.100/78,740		
-273	2x30		RND	3.830/97,280	2.900/73,660	3.220/81,790	.105/ 2,67	3.600/91,440		D
-274	2x5		SQ	1.330/33,780	.400/10,160	.720/18,290	.675/17,15	1.100/27,940		A
-275	2x7			1.530/38,860	.600/15,240	.920/23,370		1.300/33,020		C
-276	2x8			1.630/41,400	.700/17,780	1.020/25,910		1.400/35,560		D
-277	2x10			1.830/46,480	.900/22,860	1.220/30,990		1.600/40,640		
-278	2x13			2.130/54,100	1.200/30,480	1.520/38,610		1.900/48,260		
-279	2x17			2.530/64,260	1.600/40,640	1.920/48,770		2.300/58,420		
-280	2x20			2.830/71,880	1.900/48,260	2.220/56,390		2.600/66,040		
-281	2x25			3.330/84,580	2.400/60,960	2.720/69,090		3.100/78,740		
-282	2x30	STD	SQ	3.830/97,280	2.900/73,660	3.220/81,790	.675/17,15	3.600/91,440		D
-283	2x5	LP	RND	1.330/33,780	.400/10,160	.720/18,290	.105/ 2,67	1.100/27,940		A
-284	2x7			1.530/38,860	.600/15,240	.920/23,370		1.300/33,020		C
-285	2x8			1.630/41,400	.700/17,780	1.020/25,910		1.400/35,560		D
-286	2x10			1.830/46,480	.900/22,860	1.220/30,990		1.600/40,640		D
-287	2x13			2.130/54,100	1.200/30,480	1.520/38,610		1.900/48,260		D
65863-288	2x17	LP	RND	2.530/64,260	1.600/40,640	1.920/48,770	.105/ 2,67	2.300/58,420	301/.761GXT/GOLD FLASH	D

mat'l. code		tolerances unless otherwise specified		CUSTOMER COPY		FCI www.fciconnect.com	
ltr	ecr no	dr	date	linear	projection	title	
BB						HEADER, QUICKIE	
				angles	0° ±Z	SEA-HORSE, VERTICAL	
				dr	M. CORNMAN 8/21/90	product family	QUICKIE
				enrg	M. SMYK 8/21/90	size	dwg no
				chr	M. SMYK 8/21/90	scale	1:1
				appd	M. SMYK 8/21/90	A	65863
sheet	revision						code
index	sheet						11 of

ACAD

PDM: Rev:BB

STATUS: Released

Printed: Apr 12, 201

Tous droits strictement réservés. Reproduction ou communication à des tiers interdite sous quelque forme que ce soit sans autorisation écrite du propriétaire. Propriété de c FCI. Droits de reproduction FCI.



All rights strictly reserved. Reproduction or issue to third parties in any form whatever is not permitted without written authority from the proprietor. Property of FCI. Copyright FCI.

PRODUCT NO NOTE 12,13	SIZE	LATCH NOTE 8	PIN SHAPE	DIM A	DIM B	DIM C	DIM D	DIM E	TERMINAL PLATING	STYLE
65863-289	2x20	LP	RND	2.830/71,880	1.900/48,260	2.220/56,390	.105/ 2,67	2.600/66,040	301/761GXT/GOLD FLASH	D
-290	2x25		RND	3.330/84,580	2.400/60,960	2.720/69,090	.105/ 2,67	3.100/78,740		D
-291	2x30		RND	3.830/97,280	2.900/73,660	3.220/81,790	.105/ 2,67	3.600/91,440		D
-292	2x5		SQ	1.330/33,780	.400/10,160	.720/18,290	.675/17,15	1.100/27,940		A
-293	2x7			1.530/38,860	.600/15,240	.920/23,370		1.300/33,020		C
-294	2x8			1.630/41,400	.700/17,780	1.020/25,910		1.400/35,560		D
-295	2x10			1.830/46,480	.900/22,860	1.220/30,990		1.600/40,640		
-296	2x13			2.130/54,100	1.200/30,480	1.520/38,610		1.900/48,260		
-297	2x17			2.530/64,260	1.600/40,640	1.920/48,770		2.300/58,420		
-298	2x20			2.830/71,880	1.900/48,260	2.220/56,390		2.600/66,040		
-299	2x25			3.330/84,580	2.400/60,960	2.720/69,090		3.100/78,740		
-300	2x30	LP	SQ	3.830/97,280	2.900/73,660	3.220/81,790	.675/17,15	3.600/91,440	301/761GXT/GOLD FLASH	D
-301	2x5	NO	RND	1.330/33,780	.400/10,160	.720/18,290	.105/ 2,67	1.100/27,940	151/381(note 18) DVER 501/127NI	A
-302	2x7			1.530/38,860	.600/15,240	.920/23,370		1.300/33,020		C
-303	2x8			1.630/41,400	.700/17,780	1.020/25,910		1.400/35,560		D
-304	2x10			1.830/46,480	.900/22,860	1.220/30,990		1.600/40,640		
-305	2x13			2.130/54,100	1.200/30,480	1.520/38,610		1.900/48,260		
-306	2x17			2.530/64,260	1.600/40,640	1.920/48,770		2.300/58,420		
-307	2x20			2.830/71,880	1.900/48,260	2.220/56,390		2.600/66,040		
-308	2x25			3.330/84,580	2.400/60,960	2.720/69,090		3.100/78,740		
-309	2x30			3.830/97,280	2.900/73,660	3.220/81,790	.105/ 2,67	3.600/91,440		D
-310	2x5			1.330/33,780	.400/10,160	.720/18,290	.150/ 3,81	1.100/27,940		A
-311	2x7			1.530/38,860	.600/15,240	.920/23,370		1.300/33,020		C
-312	2x8			1.630/41,400	.700/17,780	1.020/25,910		1.400/35,560		D
-313	2x10			1.830/46,480	.900/22,860	1.220/30,990		1.600/40,640		
-314	2x13			2.130/54,100	1.200/30,480	1.520/38,610		1.900/48,260		
-315	2x17			2.530/64,260	1.600/40,640	1.920/48,770		2.300/58,420		
-316	2x20			2.830/71,880	1.900/48,260	2.220/56,390		2.600/66,040		
-317	2x25			3.330/84,580	2.400/60,960	2.720/69,090		3.100/78,740		
-318	2x30	NO		3.830/97,280	2.900/73,660	3.220/81,790	.150/ 3,81	3.600/91,440		D
-319	2x5	STD		1.330/33,780	.400/10,160	.720/18,290	.105/ 2,67	1.100/27,940		A
-320	2x7			1.530/38,860	.600/15,240	.920/23,370		1.300/33,020		C
-321	2x8			1.630/41,400	.700/17,780	1.020/25,910		1.400/35,560		D
-322	2x10			1.830/46,480	.900/22,860	1.220/30,990		1.600/40,640		D
-323	2x13			2.130/54,100	1.200/30,480	1.520/38,610		1.900/48,260		D
65863-324	2x17	STD	RND	2.530/64,260	1.600/40,640	1.920/48,770	.105/ 2,67	2.300/58,420	151/381(note 18) DVER 501/127NI	D

mat'l. code		tolerances unless otherwise specified		CUSTOMER COPY		www.fciconnect.com	
l	tr	ec	no	dr	date	linear	projection
BB						.XX ±.01/.X±.3	⊕
						.XXX ±.005/.XXX.13	
						.XXX ±.002/.XXX±.051	
						angles 0° ±2°	
						dr M. CORNMAN 8/21/90	INCH/MM
						engr M. SMYK 8/21/90	
						chr M. SMYK 8/21/90	scale
						appd M. SMYK 8/21/90	1:1
sheet	revision						A
index	sheet						65863
							code NT
							sheet 12 of

Tous droits strictement réservés. Reproduction ou communication à des tiers interdite sans quelque forme que ce soit sans autorisation écrite du propriétaire de c. FCJ. Droits de reproduction FCJ.



All rights strictly reserved. Reproduction or issue to third parties in any form whatever is not permitted without written authority from the proprietor. Property of FCJ. Copyright FCJ.

PRODUCT NO NOTE 12,13	SIZE	LATCH NOTE 8	PIN SHAPE	DIM A	DIM B	DIM C	DIM D	DIM E	TERMINAL PLATING	STYLE
65863-325	2x20	STD	RND	2.830/71,880	1.900/48,260	2.220/56,390	.105/ 2,67	2.600/66,040	151/.381(note 18) DVER 501/127Ni	D
-326	2x25			3.330/84,580	2.400/60,960	2.720/69,090	.105/ 2,67	3.100/78,740		D
-327	2x30			3.830/97,280	2.900/73,660	3.220/81,790	.105/ 2,67	3.600/91,440		D
-328	2x5			1.330/33,780	.400/10,160	.720/18,290	.150/ 3,81	1.100/27,940		A
-329	2x7			1.530/38,860	.600/15,240	.920/23,370		1.300/33,020		C
-330	2x8			1.630/41,400	.700/17,780	1.020/25,910		1.400/35,560		D
-331	2x10			1.830/46,480	.900/22,860	1.220/30,990		1.600/40,640		
-332	2x13			2.130/54,100	1.200/30,480	1.520/38,610		1.900/48,260		
-333	2x17			2.530/64,260	1.600/40,640	1.920/48,770		2.300/58,420		
-334	2x20			2.830/71,880	1.900/48,260	2.220/56,390		2.600/66,040		
-335	2x25			3.330/84,580	2.400/60,960	2.720/69,090		3.100/78,740		
-336	2x30	STD		3.830/97,280	2.900/73,660	3.220/81,790	.150/ 3,81	3.600/91,440		D
-337	2x5	LP		1.330/33,780	.400/10,160	.720/18,290	.105/ 2,67	1.100/27,940		A
-338	2x7			1.530/38,860	.600/15,240	.920/23,370		1.300/33,020		C
-339	2x8			1.630/41,400	.700/17,780	1.020/25,910		1.400/35,560		D
-340	2x10			1.830/46,480	.900/22,860	1.220/30,990		1.600/40,640		
-341	2x13			2.130/54,100	1.200/30,480	1.520/38,610		1.900/48,260		
-342	2x17			2.530/64,260	1.600/40,640	1.920/48,770		2.300/58,420		
-343	2x20			2.830/71,880	1.900/48,260	2.220/56,390		2.600/66,040		
-344	2x25			3.330/84,580	2.400/60,960	2.720/69,090		3.100/78,740		
-345	2x30			3.830/97,280	2.900/73,660	3.220/81,790	.105/ 2,67	3.600/91,440		D
-346	2x5			1.330/33,780	.400/10,160	.720/18,290	.150/ 3,81	1.100/27,940		A
-347	2x7			1.530/38,860	.600/15,240	.920/23,370		1.300/33,020		C
-348	2x8			1.630/41,400	.700/17,780	1.020/25,910		1.400/35,560		D
-349	2x10			1.830/46,480	.900/22,860	1.220/30,990		1.600/40,640		
-350	2x13			2.130/54,100	1.200/30,480	1.520/38,610		1.900/48,260		
-351	2x17			2.530/64,260	1.600/40,640	1.920/48,770		2.300/58,420		
-352	2x20			2.830/71,880	1.900/48,260	2.220/56,390		2.600/66,040		
-353	2x25			3.330/84,580	2.400/60,960	2.720/69,090		3.100/78,740		
-354	2x30	LP		3.830/97,280	2.900/73,660	3.220/81,790	.150/ 3,81	3.600/91,440	151/.381(note 18) DVER 501/127Ni	D
-355	2x5	NO		1.330/33,780	.400/10,160	.720/18,290	.105/ 2,67	1.100/27,940	30u"/.76u (note 18) DVER 50u"/127u Ni	B
-356		NO							151/.381(note 18) DVER 501/127Ni	
-357		NO	RND						301/.76/GXT/GOLD FLASH	
-358		NO	SQ						12012001/3.0415.081TIN/LEAD	NOTE 15,16
-359		STD	RND						30u"/.76u (note 18) DVER 50u"/127u Ni	
65863-360	2x5	STD	RND	1.330/33,780	.400/10,160	.720/18,290	.105/ 2,67	1.100/27,940	151/.381(note 18) DVER 501/127Ni	B

mat'l. code		tolerances unless otherwise specified		CUSTOMER COPY		FCJ www.fcjconnect.com	
ltr	ecn no	dr	date	linear	.xx ±.01/xx±.3	projection	title
BB				angles	.xxx ±.005/xxx±.13	1st angle	HEADER, QUICKIE
				dr	.xxx ±.0020/xxx±.051	INCH/MM	SEA-HORSE, VERTICAL
				enrg	0' ±Z'	product family	QUICKIE
				chr	M. CORNMAN 8/21/90	size	code
				appd	M. SMYK 8/21/90	scale	NT
					M. SMYK 8/21/90	1:1	65863
sheet	revision						sheet
index	sheet						13 of

Tous droits strictement réservés. Reproduction ou communication à des tiers interdite sous quelque forme que ce soit sans autorisation écrite du propriétaire. Property of FCI. Droits de reproduction FCI.



All rights strictly reserved. Reproduction or issue to third parties in any form whatever is not permitted without written authority from the proprietor. Property of FCI. Copyright FCI.

PRODUCT NO NOTE 12,13	SIZE	LATCH NOTE 8	PIN SHAPE	DIM A	DIM B	DIM C	DIM D	DIM E	TERMINAL PLATING	STYLE
65863-361	2x5	STD	RND	1.330/33,780	.400/10,160	.720/18,290	.105/ 2,67	1.100/27,940	30u"/.76u GXT/GOLD FLASH	B
-362		STD	SQ						120u-200u"/3.04u-5.08u TIN/LEAD	NOTE 15,16
-363		LP	RND						30u"/.76u (note 18) OVER 50u"/1.27u Ni	
-364		LP	RND						15u"/.38u (note 18) OVER 50u"/1.27u Ni	
-365		LP	RND						30u"/.76u GXT/GOLD FLASH	
-366		LP	SQ				.105/ 2,67		120u-200u"/3.04u-5.08u TIN/LEAD	NOTE 15,16
-367		NO	RND				.150/ 3,81		30u"/.76u (note 18) OVER 50u"/1.27u Ni	
-368		NO	RND						15u"/.38u (note 18) OVER 50u"/1.27u Ni	
-369		NO	RND						30u"/.76u GXT/GOLD FLASH	
-370		NO	SQ						120u-200u"/3.04u-5.08u TIN/LEAD	NOTE 15,16
-371		STD	RND						30u"/.76u (note 18) OVER 50u"/1.27u Ni	
-372		STD	RND						15u"/.38u (note 18) OVER 50u"/1.27u Ni	
-373		STD	RND						30u"/.76u GXT/GOLD FLASH	
-374		STD	SQ						120u-200u"/3.04u-5.08u TIN/LEAD	NOTE 15,16
-375		LP	RND						30u"/.76u (note 18) OVER 50u"/1.27u Ni	
-376		LP	RND						15u"/.38u (note 18) OVER 50u"/1.27u Ni	
-377		LP	RND						30u"/.76u GXT/GOLD FLASH	
-378		LP	SQ				.150/ 3,81		120u-200u"/3.04u-5.08u TIN/LEAD	NOTE 15,16
-379		NO					.675/17,15		30u"/.76u (note 18) OVER 50u"/1.27u Ni	
-380		NO							15u"/.38u (note 18) OVER 50u"/1.27u Ni	
-381		NO							30u"/.76u GXT/GOLD FLASH	
-382		NO							120u-200u"/3.04u-5.08u TIN/LEAD	NOTE 15,16
-383		STD							30u"/.76u (note 18) OVER 50u"/1.27u Ni	
-384		STD							15u"/.38u (note 18) OVER 50u"/1.27u Ni	
-385		STD							30u"/.76u GXT/GOLD FLASH	
-386		STD							120u-200u"/3.04u-5.08u TIN/LEAD	NOTE 15,16
-387		LP							30u"/.76u (note 18) OVER 50u"/1.27u Ni	
-388		LP							15u"/.38u (note 18) OVER 50u"/1.27u Ni	
-389		LP							30u"/.76u GXT/GOLD FLASH	
-390	2x5	LP	SQ	1.330/33,780	.400/10,160	.720/18,290	.675/17,15	1.100/27,940	120u-200u"/3.04u-5.08u TIN/LEAD	B NOTE 15,16
-391	2x9	STD	RND	1.730/43,940	.800/20,320	1.120/28,450	.105/ 2,67	1.300/33,020	30u"/.76u (note 18) OVER 50u"/1.27u Ni	D
-392	2x9	NO	RND	1.730/43,940	.800/20,320	1.120/28,450	.105/ 2,67	1.300/33,020	30u"/.76u (note 18) OVER 50u"/1.27u Ni	D
-393	2x9	LP	RND	1.730/43,940	.800/20,320	1.120/28,450	.105/ 2,67	1.300/33,020	30u"/.76u (note 18) OVER 50u"/1.27u Ni	D
-394	2x5	NO	SQ	1.330/33,780	.400/10,160	.720/18,290	.105/ 2,67	1.100/26,940	15u"/.38u (note 18) OVER 50u"/1.27u Ni	A
65863-395	2x5	STD	SQ	1.330/33,780	.400/10,160	.720/18,290	.105/ 2,67	1.100/26,940	15u"/.38u (note 18) OVER 50u"/1.27u Ni	A

mat'l. code		tolerances unless otherwise specified		CUSTOMER COPY		www.fciconnect.com	
ltr	ecn no	dr	date	linear	.xx ±.01/xx±.3	projection	title
BB					.xxx ±.005/xxx±.13	1	HEADER, QUICKIE
				angles	.xxx ±.0020/xxx±.051	1	SEA-HORSE, VERTICAL
				dr	0° ±Z	INCH/MM	product family
				enrg	M. CORNMAN 8/21/90	1	QUICKIE
				chr	M. SMYK 8/21/90	scale	size
				appd	M. SMYK 8/21/90	1:1	dwg no
sheet	revision						code
index	sheet						NT
							sheet
							14 of

ACAD PDM: Rev:BB STATUS Released cage code 65863 Printed: Apr 12, 201

Tous droits strictement reserves. Reproduction ou communication a des tiers interdite sous quelque forme que ce soit sans autorisation ecrite du proprietaire. Propriete de c FCI. Droits de reproduction FCI.



All rights strictly reserved. Reproduction or issue to third parties in any form whatever is not permitted without written authority from the proprietor. Property of FCI. Copyright FCI.

PRODUCT NO NOTE 12,13	SIZE	LATCH NOTE 8	PIN SHAPE	DIM A	DIM B	DIM C	DIM D	DIM E	TERMINAL PLATING	STYLE
65863-396	2x5	LP	SQ	1.330/33.780	.400/10.160	.720/18.290	.105/ 2.67	1.100/27.940	15u"/.38u (note 18) OVER 50u"/1.27u Ni	A
-397		ND					.150/ 3.81			
-398		STD					.150/ 3.81			
-399		LP					.150/ 3.81			A
-400		ND					.105/ 2.67			B
-401		STD					.105/ 2.67			
-402		LP					.105/ 2.67			
-403		ND					.150/ 3.81			
-404		STD					.150/ 3.81			
-405	2x5	LP		1.330/33.780	.400/10.160	.720/18.290	.150/ 3.81	1.100/27.940		B
-406	2x7	ND		1.530/38.860	.600/15.240	.920/23.370	.105/ 2.67	1.300/33.020		C
-407		STD					.105/ 2.67			
-408		LP					.105/ 2.67			
-409		ND					.150/ 3.81			
-410		STD					.150/ 3.81			
-411	2x7	LP		1.530/38.860	.600/15.240	.920/23.370	.150/ 3.81	1.300/33.020		C
-412	2x8	ND		1.630/41.400	.700/17.780	1.020/25.910	.105/ 2.67	1.400/35.560		D
-413		STD					.105/ 2.67			
-414		LP					.105/ 2.67			
-415		ND					.150/ 3.81			
-416		STD					.150/ 3.81			
-417	2x8	LP		1.630/41.400	.700/17.780	1.020/25.910	.150/ 3.81	1.400/35.560		
-418	2x10	ND		1.830/46.480	.900/22.860	1.220/30.990	.105/ 2.67	1.600/40.640		
-419		STD					.105/ 2.67			
-420		LP					.105/ 2.67			
-421		ND					.150/ 3.81			
-422		STD					.150/ 3.81			
-423	2x10	LP		1.830/46.480	.900/22.860	1.220/30.990	.150/ 3.81	1.600/40.640		
-424	2x13	ND		2.130/54.100	1.200/30.480	1.520/38.610	.105/ 2.67	1.900/48.260		
-425		STD					.105/ 2.67			
-426		LP					.105/ 2.67			
-427		ND					.150/ 3.81			
-428		STD					.150/ 3.81			
-429	2x13	LP		2.130/54.100	1.200/30.480	1.520/38.610	.150/ 3.81	1.900/48.260		
65863-430	2x17	ND	SQ	2.530/64.260	1.600/40.640	1.920/48.770	.105/ 2.67	2.300/58.420	15u"/.38u (note 18) OVER 50u"/1.27u Ni	D

mat'l. code		tolerances unless otherwise specified		CUSTOMER COPY		www.fciconnect.com	
l	tr	ec	no	dr	date	linear	projection
BB						.XX ±.01/.X±.3	1
						.XXX ±.005/.XX±.13	2
						.XXX ±.002/.XXX±.051	3
						0° ±2°	4
						dr M. CORMAN 8/21/90	INCH/MM
						engr M. SMYK 8/21/90	1
						chr M. SMYK 8/21/90	scale
						appd M. SMYK 8/21/90	1:1
sheet	revision						A
index	sheet						65863
							code NT
							sheet 15 of

Tous droits strictement réservés. Reproduction ou communication à des tiers interdite sous quelque forme que ce soit sans autorisation écrite du propriétaire. Property of FCI. Droits de reproduction FCI.



All rights strictly reserved. Reproduction or issue to third parties in any form whatever is not permitted without written authority from the proprietor. Property of FCI. Copyright FCI.

PRODUCT NO NOTES 12,13	SIZE	LATCH NOTE 8	PIN SHAPE	DIM A	DIM B	DIM C	DIM D	DIM E	TERMINAL PLATING	STYLE	PIN MISSING
65863-431	2x17	STD	SQ	2.530/64.260	1.600/40.640	1.920/48.770	.105/ 2,67	2.300/58.420	15u"/.38u (note 18) OVER 50u"/1.27u Ni	D	NONE
-432		LP					.105/ 2,67				
-433		NO					.150/ 3,81				
-434		STD					.150/ 3,81				
-435	2x17	LP		2.530/64.260	1.600/40.640	1.920/48.770	.150/ 3,81	2.300/58.420			
-436	2x20	NO		2.830/71.880	1.900/48.260	2.220/56.390	.105/ 2,67	2.600/66.040			
-437		STD					.105/ 2,67				
-438		LP					.105/ 2,67				
-439		NO					.150/ 3,81				
-440		STD					.150/ 3,81				
-441	2x20	LP		2.830/71.880	1.900/48.260	2.220/56.390	.150/ 3,81	2.600/66.040			
-442	2x25	NO		3.330/84.580	2.400/60.960	2.720/69.090	.105/ 2,67	3.100/78.740			
-443		STD					.105/ 2,67				
-444		LP					.105/ 2,67				
-445		NO					.150/ 3,81				
-446		STD					.150/ 3,81				
-447	2x25	LP		3.330/84.580	2.400/60.960	2.720/69.090	.150/ 3,81	3.100/78.740			
-448	2x30	NO		3.830/97.280	2.900/73.660	3.220/81.790	.105/ 2,67	3.600/91.440			
-449		STD					.105/ 2,67				
-450		LP					.105/ 2,67				
-451		NO					.150/ 3,81				
-452		STD					.150/ 3,81				
-453	2x30	LP	SQ	3.830/97.280	2.900/73.660	3.220/81.790	.150/ 3,81	3.600/91.440	15u"/.38u (note 18) OVER 50u"/1.27u Ni		
-454	2x12	NO	RND	2.030/51.560	1.100/27.940	1.420/36.070	.105/ 2,67	1.800/45.72	15u"/.38u (note 18) OVER 50u"/1.27u Ni		
-455	2x12	STD							15u"/.38u (note 18) OVER 50u"/1.27u Ni		
-456	2x12	LP							15u"/.38u (note 18) OVER 50u"/1.27u Ni		
-456S	2x12	LP							15u"/.38u (note 18) OVER 50u"/1.27u Ni		
-457	2x12	NO							30u"/.76u (note 18) OVER 50u"/1.27u Ni		
-458		STD							30u"/.76u (note 18) OVER 50u"/1.27u Ni		
-459		LP							30u"/.76u (note 18) OVER 50u"/1.27u Ni		
-460		NO							30u"/.76u GXT/GOLD FLASH		
-461		STD							30u"/.76u GXT/GOLD FLASH		
-462		LP	RND						30u"/.76u GXT/GOLD FLASH		
-463		NO	SQ						120u"-200u"/3.04u-5.08uTIN/LEAD		
-464		STD	SQ						120u"-200u"/3.04u-5.08uTIN/LEAD		
65863-465	2x12	LP	SQ	2.030/51.560	1.100/27.940	1.420/36.070	.105/ 2,67	1.800/45.72	120u"-200u"/3.04u-5.08uTIN/LEAD	D	NONE

NOTE 17

NOTE 15,16

NOTE 15,16

NOTE 15,16

mat'l. code		tolerances unless otherwise specified		CUSTOMER COPY		FCI www.fciconnect.com	
ltr	ecn no	dr	date	linear	projection	title	
BB				.xx ±.01/xx±.3	⊕	HEADER, QUICKIE	
				.xxx ±.005/xxx±.13	⊕	SEA-HORSE, VERTICAL	
				.xxx ±.0020/xxx±.051	0° ±Z	product family QUICKIE code	
		angles			INCH/MM	size dwg no	
		dr	M. CORNMAN	8/21/90	1:1	A 65863	
		enrg	M. SMYK	8/21/90		NT	
		chr	M. SMYK	8/21/90		sheet	
		appd	M. SMYK	8/21/90		16 of	
sheet index	revision sheet						

Tous droits strictement réservés. Reproduction ou communication à des tiers interdite sous quelque forme que ce soit sans autorisation écrite du propriétaire. Propriété de c FCI. Droits de reproduction FCI.



All rights strictly reserved. Reproduction or issue to third parties in any form whatever is not permitted without written authority from the proprietor. Property of FCI. Copyright FCI.

PRODUCT NO NOTE 12,13	SIZE	LATCH NOTE 8	PIN SHAPE	DIM A	DIM B	DIM C	DIM D	DIM E	TERMINAL PLATING	STYLE
65863-466	2x12	NO	RND	2.030/51.560	1.100/27.940	1.420/36.070	.150/3.81	1.800/45.720	15u"/.38u (note 18) OVER 50u"/1.27u Ni	D
-467		STD							15u"/.38u (note 18) OVER 50u"/1.27u Ni	
-468		LP							15u"/.38u (note 18) OVER 50u"/1.27u Ni	
-469		NO							30u"/.76u (note 18) OVER 50u"/1.27u Ni	
-470		STD							30u"/.76u (note 18) OVER 50u"/1.27u Ni	
-471		LP							30u"/.76u (note 18) OVER 50u"/1.27u Ni	
-472		NO							30u"/.76u (note 18) OVER 50u"/1.27u Ni	
-473		STD							30u"/.76u GXT/GOLD FLASH	
-474		LP	RND						30u"/.76u GXT/GOLD FLASH	
-475		NO	SQ						120u-200u"/3.04u-5.08u TIN/LEAD	NOTE 15,16
-476		STD							120u-200u"/3.04u-5.08u TIN/LEAD	NOTE 15,16
-477		LP					.150/3.81		120u-200u"/3.04u-5.08u TIN/LEAD	NOTE 15,16
-478		NO					.105/2.67		15u"/.38u (note 18) OVER 50u"/1.27u Ni	
-479		STD							15u"/.38u (note 18) OVER 50u"/1.27u Ni	
-480		LP							15u"/.38u (note 18) OVER 50u"/1.27u Ni	
-481		NO							30u"/.76u (note 18) OVER 50u"/1.27u Ni	
-482		STD							30u"/.76u (note 18) OVER 50u"/1.27u Ni	
-483		LP					.105/2.67		30u"/.76u (note 18) OVER 50u"/1.27u Ni	
-484		NO					.150/3.81		15u"/.38u (note 18) OVER 50u"/1.27u Ni	
-485		STD					.150/3.81		15u"/.38u (note 18) OVER 50u"/1.27u Ni	
-486		LP					.150/3.81		15u"/.38u (note 18) OVER 50u"/1.27u Ni	
-487		NO					.675/17.15		15u"/.38u (note 18) OVER 50u"/1.27u Ni	
-488		STD							15u"/.38u (note 18) OVER 50u"/1.27u Ni	
-489		LP							15u"/.38u (note 18) OVER 50u"/1.27u Ni	
-490		NO							30u"/.76u (note 18) OVER 50u"/1.27u Ni	
-491		STD							30u"/.76u (note 18) OVER 50u"/1.27u Ni	
-492		LP							30u"/.76u (note 18) OVER 50u"/1.27u Ni	
-493		NO							30u"/.76u GXT/GOLD FLASH	
-494		STD							30u"/.76u GXT/GOLD FLASH	
-495		LP							30u"/.76u GXT/GOLD FLASH	
-496		NO							120u-200u"/3.04u-5.08u TIN/LEAD	NOTE 15,16
-497		STD							120u-200u"/3.04u-5.08u TIN/LEAD	NOTE 15,16
-498	2x12	LP	SQ	2.030/51.560	1.100/27.940	1.420/36.070	.675/17.15	1.800/45.720	120u-200u"/3.04u-5.08u TIN/LEAD	NOTE 15,16
-499	2x15	NO	RND	2.330/59.180	1.400/35.560	1.720/43.690	.105/2.67	2.100/53.340	15u"/.38u (note 18) OVER 50u"/1.27u Ni	
65863-500	2x15	STD	RND	2.330/59.180	1.400/35.560	1.720/43.690	.105/2.67	2.100/53.340	15u"/.38u (note 18) OVER 50u"/1.27u Ni	D

mat'l. code		tolerances unless otherwise specified		CUSTOMER COPY		FCI www.fciconnect.com	
ltr	ecn no	dr	date	linear	projection	title	
BB						HEADER, QUICKIE	
				angles	0° ±Z	SEA-HORSE, VERTICAL	
				dr	M. CORNMAN	8/21/90	product family
				enrg	M. SMYK	8/21/90	QUICKIE
				chr	M. SMYK	8/21/90	code
				appd	M. SMYK	8/21/90	NT
sheet	revision						size
index	sheet						dwg no
							65863
							code
							17 of

Tous droits strictement réservés. Reproduction ou communication à des tiers interdite sous quelque forme que ce soit sans autorisation écrite du propriétaire.
 Property of FCI. Copyright FCI. Droits de reproduction FCI.



All rights strictly reserved. Reproduction or issue to third parties in any form whatever is not permitted without written authority from the proprietor.
 Property of FCI. Copyright FCI.

PRODUCT NO NOTE 12,13	SIZE	LATCH NOTE 8	PIN SHAPE	DIM A	DIM B	DIM C	DIM D	DIM E	TERMINAL PLATING	STYLE
65863-501	2x15	LP	RND	2.330/59.180	1.400/35.560	1.720/43.690	.105/2.67	2.100/53.340	15u"/.38u (note 18) OVER 50u"/1.27u Ni	D
-502		NO							30u"/.76u (note 18) OVER 50u"/1.27u Ni	
-503		STD							30u"/.76u (note 18) OVER 50u"/1.27u Ni	
-504		LP							30u"/.76u (note 18) OVER 50u"/1.27u Ni	
-505		NO							30u"/.76u GXT/GOLD FLASH	
-506		STD							30u"/.76u GXT/GOLD FLASH	
-507		LP	RND						30u"/.76u GXT/GOLD FLASH	
-508		NO	SQ						120u-200u"/3.04u-5.08u TIN/LEAD	NOTE 15,16
-509		STD	SQ						120u-200u"/3.04u-5.08u TIN/LEAD	NOTE 15,16
-510		LP	SQ				.105/2.67		120u-200u"/3.04u-5.08u TIN/LEAD	NOTE 15,16
-511		NO	RND				.150/3.81		15u"/.38u (note 18) OVER 50u"/1.27u Ni	
-512		STD							15u"/.38u (note 18) OVER 50u"/1.27u Ni	
-513		LP							15u"/.38u (note 18) OVER 50u"/1.27u Ni	
-514		NO							30u"/.76u (note 18) OVER 50u"/1.27u Ni	
-515		STD							30u"/.76u (note 18) OVER 50u"/1.27u Ni	
-516		LP							30u"/.76u (note 18) OVER 50u"/1.27u Ni	
-517		NO							30u"/.76u GXT/GOLD FLASH	
-518		STD							30u"/.76u GXT/GOLD FLASH	
-519		LP	RND						30u"/.76u GXT/GOLD FLASH	
-520		NO	SQ						120u-200u"/3.04u-5.08u TIN/LEAD	NOTE 15,16
-521		STD							120u-200u"/3.04u-5.08u TIN/LEAD	NOTE 15,16
-522		LP					.150/3.81		120u-200u"/3.04u-5.08u TIN/LEAD	NOTE 15,16
-523		NO					.105/2.67		15u"/.38u (note 18) OVER 50u"/1.27u Ni	
-524		STD							15u"/.38u (note 18) OVER 50u"/1.27u Ni	
-525		LP							15u"/.38u (note 18) OVER 50u"/1.27u Ni	
-526		NO							30u"/.76u (note 18) OVER 50u"/1.27u Ni	
-527		STD							30u"/.76u (note 18) OVER 50u"/1.27u Ni	
-528		LP					.105/2.67		30u"/.76u (note 18) OVER 50u"/1.27u Ni	
-529		NO					.150/3.81		15u"/.38u (note 18) OVER 50u"/1.27u Ni	
-530		STD					.150/3.81		15u"/.38u (note 18) OVER 50u"/1.27u Ni	
-531		LP					.150/3.81		15u"/.38u (note 18) OVER 50u"/1.27u Ni	
-532		NO					.675/17.15		15u"/.38u (note 18) OVER 50u"/1.27u Ni	
-533		STD							15u"/.38u (note 18) OVER 50u"/1.27u Ni	
-534		LP							15u"/.38u (note 18) OVER 50u"/1.27u Ni	
65863-535	2x15	NO	SQ	2.330/59.180	1.400/35.560	1.720/43.690	.675/17.15	2.100/53.340	30u"/.76u (note 18) OVER 50u"/1.27u Ni	D

mat'l. code		tolerances unless otherwise specified		CUSTOMER COPY		FCI www.fciconnect.com	
ltr	ecn no	dr	date	linear	projection	title	
BB						HEADER, QUICKIE	
				angles	0° ±Z	SEA-HORSE, VERTICAL	
				dr	M. CORNMAN 8/21/90	product family	code
				enrg	M. SMYK 8/21/90	size	NT
				chr	M. SMYK 8/21/90	dwg no	sheet
				appd	M. SMYK 8/21/90	scale	18 of
sheet	revision					A	65863
index	sheet						

Tous droits strictement réservés. Reproduction ou communication à des tiers interdite sans quelque forme que ce soit sans autorisation écrite du propriétaire. Property of FCI. Droits de reproduction FCI.



All rights strictly reserved. Reproduction or issue to third parties in any form whatever is not permitted without written authority from the proprietor. Property of FCI. Copyright FCI.

PRODUCT NO NOTE 12,13	SIZE	LATCH NOTE 8	PIN SHAPE	DIM A	DIM B	DIM C	DIM D	DIM E	TERMINAL PLATING	STYLE
65863-536	2x15	STD	SQ	2.330/59.180	1.400/35.560	1.720/43.690	.675/17.15	2.100/53.340	30u"/.76u (note 18) OVER 50u"/1.27u Ni	D
-537		LP							30u"/.76u (note 18) OVER 50u"/1.27u Ni	
-538		NO							30u"/.76u GXT/GOLD FLASH	
-539		STD							30u"/.76u GXT/GOLD FLASH	
-540		LP							30u"/.76u GXT/GOLD FLASH	
-541		NO							120u-200u"/3.04u-5.08u TIN/LEAD	NOTE 15,16
-542		STD							120u-200u"/3.04u-5.08u TIN/LEAD	NOTE 15,16
-543	2x15	LP	SQ	2.330/59.180	1.400/35.560	1.720/43.690	.675/17.15	2.100/53.340	120u-200u"/3.04u-5.08u TIN/LEAD	NOTE 15,16
-544	2x22	NO	RND	3.030/76.960	2.100/53.340	2.420/61.470	.105/2.67	2.800/71.120	15u"/.38u (note 18) OVER 50u"/1.27u Ni	
-545		STD							15u"/.38u (note 18) OVER 50u"/1.27u Ni	
-546		LP							15u"/.38u (note 18) OVER 50u"/1.27u Ni	
-547		NO							30u"/.76u (note 18) OVER 50u"/1.27u Ni	
-548		STD							30u"/.76u (note 18) OVER 50u"/1.27u Ni	
-549		LP							30u"/.76u (note 18) OVER 50u"/1.27u Ni	
-550		NO							30u"/.76u GXT/GOLD FLASH	
-551		STD							30u"/.76u GXT/GOLD FLASH	
-552		LP	RND						30u"/.76u GXT/GOLD FLASH	
-553		NO	SQ						120u-200u"/3.04u-5.08u TIN/LEAD	NOTE 15,16
-554		STD	SQ						120u-200u"/3.04u-5.08u TIN/LEAD	NOTE 15,16
-555		LP	SQ				.105/2.67		120u-200u"/3.04u-5.08u TIN/LEAD	NOTE 15,16
-556		NO	RND				.150/3.81		15u"/.38u (note 18) OVER 50u"/1.27u Ni	
-557		STD							15u"/.38u (note 18) OVER 50u"/1.27u Ni	
-558		LP							15u"/.38u (note 18) OVER 50u"/1.27u Ni	
-559		NO							30u"/.76u (note 18) OVER 50u"/1.27u Ni	
-560		STD							30u"/.76u (note 18) OVER 50u"/1.27u Ni	
-561		LP							30u"/.76u (note 18) OVER 50u"/1.27u Ni	
-562		NO							30u"/.76u GXT/GOLD FLASH	
-563		STD							30u"/.76u GXT/GOLD FLASH	
-564		LP	RND						30u"/.76u GXT/GOLD FLASH	
-565		NO	SQ						120u-200u"/3.04u-5.08u TIN/LEAD	NOTE 15,16
-566		STD							120u-200u"/3.04u-5.08u TIN/LEAD	NOTE 15,16
-567		LP					.150/3.81		120u-200u"/3.04u-5.08u TIN/LEAD	NOTE 15,16
-568		NO					.105/2.67		15u"/.38u (note 18) OVER 50u"/1.27u Ni	
-569		STD					.105/2.67		15u"/.38u (note 18) OVER 50u"/1.27u Ni	
65863-570	2x22	LP	SQ	3.030/76.960	2.100/53.340	2.420/61.470	.105/2.67	2.800/71.120	15u"/.38u (note 18) OVER 50u"/1.27u Ni	D

mat'l. code		tolerances unless otherwise specified		CUSTOMER COPY		FCI www.fciconnect.com	
ltr	ecr no	dr	date	linear	projection	title	
BB				.xx ±.01/xx±.3	⊕	HEADER, QUICKIE	
				.xxx ±.005/xxx±.13	⊕	SEA-HORSE, VERTICAL	
				.xxx ±.0020/xxx±.051	0° ±Z	product family	code
				angles	INCH/MM	QUICKIE	NT
				dr	M. CORNMAN	8/21/90	size
				enrg	M. SMYK	8/21/90	dwg no
				chr	M. SMYK	8/21/90	65863
				appd	M. SMYK	8/21/90	sheet
sheet	revision				scale	1:1	19 of
index	sheet						

Tous droits strictement réservés. Reproduction ou communication à des tiers interdite sans quelque forme que ce soit sans autorisation écrite du propriétaire. Property of FCI. Droits de reproduction FCI.



All rights strictly reserved. Reproduction or issue to third parties in any form whatever is not permitted without written authority from the proprietor. Property of FCI. Copyright FCI.

PRODUCT NO NOTE 12,13	SIZE	LATCH NOTE 8	PIN SHAPE	DIM A	DIM B	DIM C	DIM D	DIM E	TERMINAL PLATING	STYLE
65863-571	2x22	NO	SQ	3.030/76.960	2.100/53.340	2.420/61.470	.105/2.67	2.800/71.120	30u"/.76u (note 18) OVER 50u"/1.27u Ni	D
-572		STD					.105/2.67		30u"/.76u (note 18) OVER 50u"/1.27u Ni	
-573		LP					.105/2.67		30u"/.76u (note 18) OVER 50u"/1.27u Ni	
-574		NO					.150/3.81		15u"/.38u (note 18) OVER 50u"/1.27u Ni	
-575		STD					.150/3.81		15u"/.38u (note 18) OVER 50u"/1.27u Ni	
-576		LP					.150/3.81		15u"/.38u (note 18) OVER 50u"/1.27u Ni	
-577		NO					.675/17.15		15u"/.38u (note 18) OVER 50u"/1.27u Ni	
-578		STD							15u"/.38u (note 18) OVER 50u"/1.27u Ni	
-579		LP							15u"/.38u (note 18) OVER 50u"/1.27u Ni	
-580		NO							30u"/.76u (note 18) OVER 50u"/1.27u Ni	
-581		STD							30u"/.76u (note 18) OVER 50u"/1.27u Ni	
-582		LP							30u"/.76u (note 18) OVER 50u"/1.27u Ni	
-583		NO							30u"/.76u GXT/GOLD FLASH	
-584		STD							30u"/.76u GXT/GOLD FLASH	
-585		LP							30u"/.76u GXT/GOLD FLASH	
-586		NO							120u-200u"/3.04u-5.08u TIN/LEAD	NOTE 15,16
-587		STD							120u-200u"/3.04u-5.08u TIN/LEAD	NOTE 15,16
-588	2x22	LP		3.030/76.960	2.100/53.340	2.420/61.470	.675/17.15	2.800/71.120	120u-200u"/3.04u-5.08u TIN/LEAD	NOTE 15,16
-589	2x25	STD	SQ	3.330/84.580	2.400/60.960	2.720/69.090	.150/3.81	3.100/78.740	30u"/.76u (note 18) OVER 50u"/1.27u Ni	
-590		66258	RND				.105/2.67			
-591		66258	RND				.150/3.81			
-592	2x25	NO	SQ	3.330/84.580	2.400/60.960	2.720/69.090		3.100/78.740	30u"/.76u (note 18) OVER 50u"/1.27u Ni	
-593	2x13	LP		2.130/54.100	1.200/30.480	1.520/38.610		1.900/48.260	50u"/1.27u (note 18) OVER 50u"/1.27u Ni	
-594	2x13	NO		2.130/54.100	1.200/30.480	1.520/38.610	.150/3.81	1.900/48.260		
-595	2x10	NO		1.830/46.480	.900/22.860	1.220/30.990	.150/3.81	1.600/40.640		
-596	2x10	STD		1.830/46.480	.900/22.860	1.220/30.990	.150/3.81	1.600/40.640		D
-597	2x5	LP		1.330/33.780	.400/10.160	.720/18.290	.150/3.81	1.100/27.940		A
-598	2x5	NO		1.330/33.780	.400/10.160	.720/18.290	.150/3.81	1.100/27.940		A
-599	2x5	LP		1.330/33.780	.400/10.160	.720/18.290	.675/17.15	1.100/27.940		A
-600	2x5	NO	SQ	1.330/33.780	.400/10.160	.720/18.290	.675/17.15	1.100/27.940	50u"/1.27u (note 18) OVER 50u"/1.27u Ni	A
-601	2X32	NO	RND	4.030/102.360	3.100/78.740	3.420/86.870	.105/2.67	3.800/96.520	15u"/.38u (note 18) OVER 50u"/1.27u Ni	D
-602	2X32	STD	RND	4.030/102.360	3.100/78.740	3.420/86.870	.105/2.67	3.800/96.520	15u"/.38u (note 18) OVER 50u"/1.27u Ni	D
-603	2X32	LP	RND	4.030/102.360	3.100/78.740	3.420/86.870	.105/2.67	3.800/96.520	15u"/.38u (note 18) OVER 50u"/1.27u Ni	D
65863-604	2X32	NO	RND	4.030/102.360	3.100/78.740	3.420/86.870	.105/2.67	3.800/96.520	30u"/.76u (note 18) OVER 50u"/1.27u Ni	D

mat'l. code		tolerances unless otherwise specified		CUSTOMER COPY	www.fciconnect.com
ltr	ecn no	dr	date	projection	
BB				$\begin{matrix} \phi \\ \leftarrow \end{matrix}$	title
				$\begin{matrix} \phi \\ \leftarrow \end{matrix}$	HEADER, QUICKIE SEA-HORSE, VERTICAL
				$\begin{matrix} \phi \\ \leftarrow \end{matrix}$	product family
				$\begin{matrix} \phi \\ \leftarrow \end{matrix}$	QUICKIE
				$\begin{matrix} \phi \\ \leftarrow \end{matrix}$	code
				$\begin{matrix} \phi \\ \leftarrow \end{matrix}$	NT
				$\begin{matrix} \phi \\ \leftarrow \end{matrix}$	sheet
				$\begin{matrix} \phi \\ \leftarrow \end{matrix}$	20 of
sheet	revision			scale	
index	sheet			1:1	
					cage code
					65863

Tous droits strictement réservés. Reproduction ou communication à des tiers interdite sous quelque forme que ce soit sans autorisation écrite du propriétaire. Property of FCI. Droits de reproduction FCI.



All rights strictly reserved. Reproduction or issue to third parties in any form whatever is not permitted without written authority from the proprietor. Property of FCI. Copyright FCI.

PRODUCT NO NOTE 12,13	SIZE	LATCH NOTE 8	PIN SHAPE	DIM A	DIM B	DIM C	DIM D	DIM E	TERMINAL PLATING	STYLE
65863-605	2X32	STD	RND	4.030/102.360	3.100/78.740	3.420/86.870	.105/2.67	3.800/96.520	30u"/.76u (note 18) OVER 50u"/1.27u Ni	D
-606		LP							30u"/.76u (note 18) OVER 50u"/1.27u Ni	
-607		NO							30u"/.76u GXT OVER 50u"/1.27u Ni	
-608		STD							30u"/.76u GXT OVER 50u"/1.27u Ni	
-609		LP	RND						30u"/.76u GXT OVER 50u"/1.27u Ni	
-610		NO	SQ						120u-200u"/3.04u-5.08u TIN/LEAD	NOTE 15,16
-611		STD							120u-200u"/3.04u-5.08u TIN/LEAD	NOTE 15,16
-612	2X32	LP		4.030/102.360	3.100/78.740	3.420/86.870	.105/2.67	3.800/96.520	120u-200u"/3.04u-5.08u TIN/LEAD	NOTE 15,16
-613	2x20	NO		2.830/71.880	1.900/48.260	2.220/56.390	.105/ 2,67	2.600/66.040	30u"/.76u GXT/GOLD FLASH	
-614	2x20	STD		2.830/71.880	1.900/48.260	2.220/56.390	.105/ 2,67	2.600/66.040	30u"/.76u GXT/GOLD FLASH	
-615	2x20	LP		2.830/71.880	1.900/48.260	2.220/56.390	.105/ 2,67	2.600/66.040	30u"/.76u GXT/GOLD FLASH	
-616	2x25	NO		3.330/84.580	2.400/60.960	2.720/69.090	.450/ 11,43	3.100/78.740	30u"/.76u (note 18) OVER 50u"/1.27u Ni	
-617	2x17	NO		2.530/64.260	1.600/40.640	1.920/48.770	.150/ 3,81	2.300/58.420	50u"/1.27u (note 18) OVER 50u"/1.27u Ni	
-618	2x17	STD		2.530/64.260	1.600/40.640	1.920/48.770	.150/ 3,81	2.300/58.420	50u"/1.27u (note 18) OVER 50u"/1.27u Ni	
-619	2x17	LP		2.530/64.260	1.600/40.640	1.920/48.770	.150/ 3,81	2.300/58.420	50u"/1.27u (note 18) OVER 50u"/1.27u Ni	
-620	2X32	STD		4.030/102.360	3.100/78.740	3.420/86.870	.105/2.67	3.800/96.520	30u"/.76u GXT OVER 50u"/1.27u Ni	
-621	2X32	NO		4.030/102.360	3.100/78.740	3.420/86.870		3.800/96.520		
-622	2x15	STD		2.330/59.180	1.400/35.560	1.720/43.690		2.100/53.340		
-623	2x15	NO		2.330/59.180	1.400/35.560	1.720/43.690		2.100/53.340		
-624	2x22	STD		3.030/76.960	2.100/53.340	2.420/61.470		2.800/71.120		
-625	2x22	NO		3.030/76.960	2.100/53.340	2.420/61.470	.105/2.67	2.800/71.120	30u"/.76u GXT OVER 50u"/1.27u Ni	
-626	2x25	NO		3.330/84.580	2.400/60.960	2.720/69.090	.150/ 3,81	3.100/78.740	50u"/1.27u (note 18) OVER 50u"/1.27u Ni	
-627	2x25	STD		3.330/84.580	2.400/60.960	2.720/69.090		3.100/78.740		
-628	2x25	LP		3.330/84.580	2.400/60.960	2.720/69.090		3.100/78.740		
-629	2x20	NO		2.830/71.880	1.900/48.260	2.220/56.390		2.600/66.040		
-630	2x20	STD		2.830/71.880	1.900/48.260	2.220/56.390		2.600/66.040		
-631	2x20	LP	SQ	2.830/71.880	1.900/48.260	2.220/56.390	.150/ 3,81	2.600/66.040	50u"/1.27u (note 18) OVER 50u"/1.27u Ni	
-632	2x20	STD	RND	2.830/71.880	1.900/48.260	2.220/56.390	.105/2.67	2.600/66.040	30u"/.76u (note 18) OVER 50u"/1.27u Ni	
-633	2x8	STD	RND	1.630/41.40	.700/17.78	1.020/25.91	.150/ 3,81	1.400/35.56	50u"/1.27u (note 18) OVER 50u"/1.27u Ni	D
-634	2x7	NO	RND	1.530/38.86	.600/15.24	.920/23.37	.236/ 5,99	1.300/33.02	30u"/.76u GXT OVER 50u"/1.27u Ni	C
-635	2x5	STD	RND	1.330/33.78	.400/10.16	.720/18.29	.520/13.21	1.100/27.94	30u"/.76u GXT OVER 50u"/1.27u Ni	A
-636	2x8	NO	SQ	1.630/41.40	.700/17.78	1.020/25.91	.150/ 3,81	1.400/35.56	30u"/.76u (note 18) OVER 50u"/1.27u Ni	D
-637	2x8	STD	SQ	1.630/41.40	.700/17.78	1.020/25.91	.150/ 3,81	1.400/35.56	30u"/.76u (note 18) OVER 50u"/1.27u Ni	D
-638	2x10	NO	SQ	1.830/46.48	.800/20.32	1.220/30.99	.150/ 3,81	1.600/40.64	30u"/.76u (note 18) OVER 50u"/1.27u Ni	D
65863-639	2x10	STD	SQ	1.830/46.48	.800/20.32	1.220/30.99	.150/ 3,81	1.600/40.64	30u"/.76u (note 18) OVER 50u"/1.27u Ni	D CUSTOMER SPECIAL

mat'l. code		tolerances unless otherwise specified		CUSTOMER COPY		www.fciconnect.com	
ltr	ecn no	dr	date	linear	projection	title	
BB					1st angle	HEADER, QUICKIE	
				angles	0° ±Z	SEA-HORSE, VERTICAL	
				dr	M. CORNMAN	8/21/90	product family
				enrg	M. SMYK	8/21/90	QUICKIE
				chr	M. SMYK	8/21/90	code
				appd	M. SMYK	8/21/90	NT
sheet	revision						size
index	sheet						dwg no
							65863
							sheet
							21 of

Tous droits strictement réservés. Reproduction ou communication à des tiers
 interdite sous quelque forme que ce soit sans autorisation écrite du
 propriétaire de FCI. Droits de reproduction FCI.



All rights strictly reserved. Reproduction or issue to third parties in any
 form whatever is not permitted without written authority from the proprietor.
 Property of FCI. Copyright FCI.

PRODUCT NO NOTE 12,13	SIZE	LATCH NOTE 8	PIN SHAPE	DIM A	DIM B	DIM C	DIM D	DIM E	TERMINAL PLATING	STYLE	PIN MISSING
65863-640	2x12	NO	SQ	2.030/ 51.56	1.100/ 27.94	1.420/ 36.07	.150/3,81	1.800/ 45.72	30u"/.76u (note 18) OVER 50u"/1.27u Ni	D	NONE
-641	2x12	STD		2.030/ 51.56	1.100/ 27.94	1.420/ 36.07		1.800/ 45.72			
-642	2x15	NO		2.330/ 59.18	1.400/ 35.56	1.720/ 43.69		2.100/ 53.34			
-643	2x15	STD		2.330/ 59.18	1.400/ 35.56	1.720/ 43.69		2.100/ 53.34			
-644	2x30	NO		3.830/ 97.28	2.900/ 73.66	3.220/ 81.79		3.600/ 91.44			
-645	2x30	STD	SQ	3.830/ 97.28	2.900/ 73.66	3.220/ 81.79		3.600/ 91.44			
-646	2x25	STD	RND	3.330/ 84.58	2.400/ 60.96	2.720/ 69.09		3.100/ 78.74		D	
-647	2x5	STD	SQ	1.330/ 33.78	.400/ 10.16	.720/ 18.29		1.100/ 27.94		A	
-648	2x7	STD		1.530/ 38.86	.600/ 15.24	.920/ 23.37		1.300/ 33.02		C	
-649	2x13	STD		2.130/ 54.10	1.120/ 30.48	1.520/ 38.61		1.900/ 48.26		D	
-650	2x17	STD		2.530/ 64.26	1.600/ 40.64	1.920/ 48.77		2.300/ 58.42		D	
-651	2x5	NO		1.330/ 33.78	.400/ 10.16	.720/ 18.29		1.100/ 27.94		A	
-652	2x7	NO		1.530/ 38.86	.600/ 15.24	.920/ 23.37		1.300/ 33.02		C	
-653	2x13	NO		2.130/ 54.10	1.120/ 30.48	1.520/ 38.61		1.900/ 48.26		D	
-654	2x17	NO	SQ	2.530/ 64.26	1.600/ 40.64	1.920/ 48.77	.150/3,81	2.300/ 58.42		D	
-655	2x5	STD	RND	1.330/ 33.78	.400/ 10.16	.720/ 18.29	.175/4,45	1.100/ 27.94		A	
-656	2x7			1.530/ 38.86	.600/ 15.24	.920/ 23.37		1.300/ 33.02		C	
-657	2x13			2.130/ 54.10	1.120/ 30.48	1.520/ 38.61		1.900/ 48.26		D	
-658	2x17	STD	RND	2.530/ 64.26	1.600/ 40.64	1.920/ 48.77	.175/4,45	2.300/ 58.42		D	
-659	2x5	NO	SQ	1.330/ 33.78	.400/ 10.16	.720/18.29	.250/6,35	1.100/ 27.94		A	
-660	2x7	LP	RND	1.530/ 38.86	.600/ 15.24	.920/ 23.37	.236/5,99	1.300/ 33.02	30u"/.76u (note 18) OVER 50u"/1.27u Ni	C	NONE
-715	2x8	LP		1.680/ 41.40	.700/ 17.78	1.020/ 25.91	.150/3,81	1.400/ 35.56	30u"/.76u GXT OVER 50u"/1.27u Ni	D	3
-716	2x8	LP		1.680/ 41.40	.700/ 17.78	1.020/ 25.91	.150/3,81	1.400/ 35.56	30u"/.76u (note 18) OVER 50u"/1.27u Ni	D	14
-717	2X20	LP		2.830/71.88	1.900/48.26	2.220/56.38	.150/3,81	2.600/ 66.04	30u"/.76u GXT OVER 50u"/1.27u Ni	D	20
-717S	2X20	LP		2.830/71.88	1.900/48.26	2.220/56.38	.150/3,81	2.600/ 66.04	30u"/.76u GXT OVER 50u"/1.27u Ni	D	20
-733	2x17	LP		2.530/ 64.26	1.600/ 40.64	1.920/ 48.77	.105/2,67	2.300/ 58.42	50u"/1.27u (note 18) OVER 50u"/1.27u Ni	D	5
-734	2x17	STD		2.530/ 64.26	1.600/ 40.64	1.920/ 48.77	.105/2,67	2.300/ 58.42	50u"/1.27u (note 18) OVER 50u"/1.27u Ni	D	5
-735	2x10	LP		1.830/46.48	.900/ 22.86	1.220/ 30.99	.150/3,81	1.600/ 40.64	30u"/.76u GXT OVER 50u"/1.27u Ni	D	16
-736	2x10	LP		1.830/46.48	.900/ 22.86	1.220/ 30.99		1.600/ 40.64	30u"/.76u GXT OVER 50u"/1.27u Ni	D	19
-737	2x5	LP		1.330/33.78	.400/ 10.16	.720/ 18.29		1.100/ 27.94	30u"/.76u (note 18) OVER 50u"/1.27u Ni	A	10
-738	2X20	LP		2.830/71.88	1.900/48.26	2.220/56.38		2.600/ 66.04	30u"/.76u GXT OVER 50u"/1.27u Ni	D	8
-739	2X25	LP		3.330/84.58	2.400/60.96	2.720/69.09		3.100/ 78.74		D	25
-740	2X12	LP		2.030/ 51.56	1.100/ 27.94	1.420/ 36.07		1.800/ 45.72		D	20
-741	2X17	LP		2.530/ 64.26	1.600/ 40.64	1.920/ 48.77		2.300/ 58.42		D	5
-741S	2X17	LP		2.530/ 64.26	1.600/ 40.64	1.920/ 48.77		2.300/ 58.42		D	5
-742	2X5	LP		1.330/ 33.78	.400/ 10.16	.720/ 18.29		1.100/ 27.94		A	2
65863-743	2X17	LP	RND	2.530/ 64.26	1.600/ 40.64	1.920/ 48.77	.150/3,81	2.300/ 58.42	30u"/.76u GXT OVER 50u"/1.27u Ni	D	3

NOTE 17

NOTE 17

mat'l. code		tolerances unless otherwise specified		CUSTOMER COPY		www.fciconnect.com	
ltr	ecn no	dr	date	linear	projection	title	
BB				.xx ±01/xx±3	1	HEADER, QUICKIE	
				.xxx ±005/xxx±13		SEA-HORSE, VERTICAL	
				.xxx ±0020/xxx±051		product family	code
				angles		QUICKIE	NT
				0° ±2°		size	sheet
				dr M. CORNMAN 8/21/90	INCH/MM	65863	22 of
				enrg M. SMYK 8/21/90	scale		
				chr M. SMYK 8/21/90	1:1		
				appa M. SMYK 8/21/90			
sheet index	revision						
	sheet						

1 | 2

3 |

4

Tous droits strictement réservés. Reproduction ou communication à des tiers
 interdite sous quelque forme que ce soit sans autorisation écrite du
 propriétaire de FCI. Droits de reproduction FCI.



All rights strictly reserved. Reproduction or issue to third parties in any
 form whatever is not permitted without written authority from the proprietor.
 Property of FCI. Copyright FCI.

PRODUCT NO NOTE 12,13	SIZE	LATCH NOTE 8	PIN SHAPE	DIM A	DIM B	DIM C	DIM D	DIM E	TERMINAL PLATING	STYLE	MISSING PIN	
65863-744	2x17	LP	RND	2.530/ 64.26	1.600/ 40.64	1.920/ 48.77	.150/3.81	2.300/ 58.42	30u"/.76u GXT OVER 50u"/1.27u Ni	D	3, 5	NOTE 17
65863-744S	2x17	LP	RND	2.530/ 64.26	1.600/ 40.64	1.920/ 48.77	.150/3.81	2.300/ 58.42	30u"/.76u GXT OVER 50u"/1.27u Ni	D	3, 5	
65863-843	2x5	N/A	RND	1.330/ 33.78	.400/ 10.16	.720/ 18.29	.120/3.05	1.100/ 27.94	15u"/.38u (note 18) OVER 50u"/1.27u Ni	A		N/A
-844	2x7			1.530/ 38.86	.600/ 15.24	.920/ 23.37		1.300/ 33.02		C		
-845	2x10			1.830/ 46.48	.900/ 22.86	1.220/ 30.99		1.600/ 40.64		D		
-846	2x15			2.330/ 59.18	1.400/ 35.56	1.720/ 43.69		2.100/ 53.34				
-847	2x17			2.530/ 64.26	1.600/ 40.64	1.920/ 48.77		2.300/ 58.42				
-848	2X20			2.830/ 71.88	1.900/ 48.26	2.220/ 56.38		2.600/ 66.04				
-849	2X25			3.330/ 84.58	2.400/ 60.96	2.720/ 69.69		3.100/ 78.74				
-850	2x30	N/A		3.830/ 97.28	2.900/ 73.66	3.220/ 81.79		3.600/ 91.44		D		
-851	2x5	STD		1.330/ 33.78	.400/ 10.16	.720/ 18.29		1.100/ 27.94		A		
-852	2x7			1.530/ 38.86	.600/ 15.24	.920/ 23.37		1.300/ 33.02		C		
-853	2x10			1.830/ 46.48	.900/ 22.86	1.220/ 30.99		1.600/ 40.64		D		
-854	2x15			2.330/ 59.18	1.400/ 35.56	1.720/ 43.69		2.100/ 53.34				
-855	2x17			2.530/ 64.26	1.600/ 40.64	1.920/ 48.77		2.300/ 58.42				
-856	2X20			2.830/ 71.88	1.900/ 48.26	2.220/ 56.38		2.600/ 66.04				
-857	2X25			3.330/ 84.58	2.400/ 60.96	2.720/ 69.69		3.100/ 78.74				
-858	2x30	STD		3.830/ 97.28	2.900/ 73.66	3.220/ 81.79		3.600/ 91.44		D		
-859	2x5	L/P		1.330/ 33.78	.400/ 10.16	.720/ 18.29		1.100/ 27.94		A		
-860	2x7			1.530/ 38.86	.600/ 15.24	.920/ 23.37		1.300/ 33.02		C		
-861	2x10			1.830/ 46.48	.900/ 22.86	1.220/ 30.99		1.600/ 40.64		D		
-861S	2x10			1.830/ 46.48	.900/ 22.86	1.220/ 30.99		1.600/ 40.64		D		
-862	2x15			2.330/ 59.18	1.400/ 35.56	1.720/ 43.69		2.100/ 53.34				
-863	2x17			2.530/ 64.26	1.600/ 40.64	1.920/ 48.77		2.300/ 58.42				
-864	2X20			2.830/ 71.88	1.900/ 48.26	2.220/ 56.38		2.600/ 66.04				
-865	2X25			3.330/ 84.58	2.400/ 60.96	2.720/ 69.69		3.100/ 78.74				
65863-866	2x30	L/P	RND	3.830/ 97.28	2.900/ 73.66	3.220/ 81.79	.120/3.05	3.600/ 91.44	15u"/.38u (note 18) OVER 50u"/1.27u Ni	D		NOTE 17
65863-867S	2x12	L/P	RND	2.030/ 51.56	1.100/ 27.94	1.420/ 36.07	.105/2.67	1.800/ 45.72	15u"/.38u (note 18) OVER 50u"/1.27u Ni	D	24	
65863-868S	2x12	L/P	RND	2.030/ 51.56	1.100/ 27.94	1.420/ 36.07	.105/2.67	1.800/ 45.72	30u"/0.76um GXT OVER 50u"/1.27um Ni	D	24	NOTE 17

mat'l. code		tolerances unless otherwise specified		CUSTOMER COPY		www.fciconnect.com	
ltr	ecrn no	dr	date	linear	projection	title	
BB				.xx ±01/xx±3	⊕	HEADER, QUICKIE	
				.xxx ±005/xxx±13		SEA-HORSE, VERTICAL	
				.xxx ±0020/xxx±051		product family	QUICKIE
				angles	INCH/MM	size	dwg no
				0° ±2°		A	65863
				dr	M. CORNMANN	8/21/90	code
				engr	M. SMYK	8/21/90	NT
				chr	M. SMYK	8/21/90	sheet
				appd	M. SMYK	8/21/90	23 of
sheet	revision						
index	sheet						