

4

3

2

1

THIS DRAWING IS UNPUBLISHED. RELEASED FOR PUBLICATION. ALL RIGHTS RESERVED.

LOC		DIST		REVISIONS			
FT	0	F	LNK	DESCRIPTION	DATE	BY	APP
		S2		REVISED PER ECO-11-004820	11MAR11	RK	HMR

MOUNTING TAB  
2 PLC  
SEE TABLE

2.64±0.10 DIA  
[.104±.004]  
2 HOLES

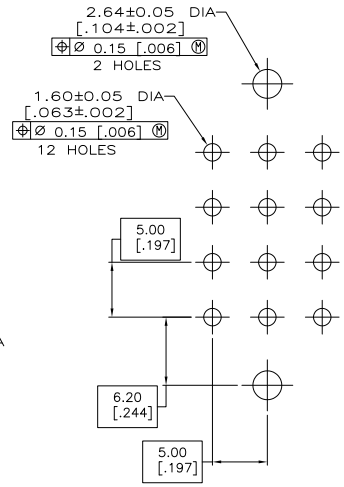
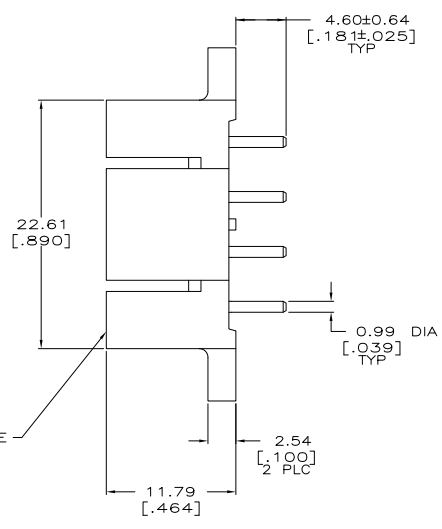
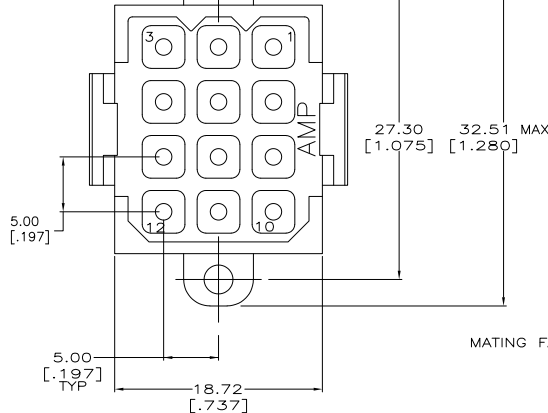

RECOMMENDED PC BOARD LAYOUT

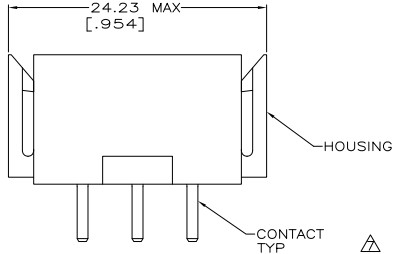

- ▲ NYLON, UL 94V-0 RATED, RED.
- ▲ BRASS PER ASTM B36.
- ▲ 3.81um [.000150] MIN TIN OVER 2.54um [.000100] MIN COPPER.
- ▲ 0.76um [.000030] MIN GOLD FOR A LENGTH OF 5.08 [.200] FROM MATING END, 3.81um [.000150] MIN TIN-LEAD FOR A LENGTH OF 4.83 [.190] MIN FROM OPPOSITE END, BOTH OVER 1.27um [.000050] MIN NICKEL.
- ▲ SELECTIVELY LOADED CONTACTS IN POSITIONS 1 THRU 5, 7 THRU 12.
- ▲ 3.81um [.000150] MIN TIN OVER 2.54um [.000100] MIN COPPER.

▲ SUPERSEDED BY 1-207120-2

▲ 0.76um [.000030] MIN GOLD FOR A LENGTH OF 5.08 [.200] FROM MATING END, 3.81um [.000150] MIN TIN FOR A LENGTH OF 4.83 [.190] MIN FROM OPPOSITE END, BOTH OVER 1.27um [.000050] MIN NICKEL.

▲ OBSOLETE PARTS: OBSOLETE CIS STREAMLINING PER D.RENAUD/D.SINISI

▲	YES	▲ 1-207120-2
▲	NO	1-207120-1
▲	NO	1-207120-0
▲	YES	207120-9
▲	YES	207120-8
▲	YES	207120-7
▲	NO	207120-4
▲	YES	207120-3
▲	NO	207120-2
▲	YES	207120-1

THIS DRAWING IS A CONTROLLED DOCUMENT. DW 03/11/92  
L. SHIP 3-17-92  
C. STONE  
R. STONE

TE Connectivity

PIN HEADER ASSEMBLY, 12 POSITION, METRIMATE

108-10033

SIZE: A2 CASE CODE: C=207120

CUSTOMER DRAWING SCALE: 4:1 SHEET: 1 of 1 REV: S2