

REV	DATE	DESCRIPTION	BY	CHK	APP
AD	00				
NS		REVISED PER ECU-11-004587	11MMR11	RK	HMR

△ THE NOTED DIMENSION APPLIES AT THE INTERSECTION OF THE POST AND HOUSING
 △ POINT OF MEASUREMENT FOR PLATING THICKNESS.
 △ POSTS: .000030 GOLD IN CONTACT AREA .000100-.000200 MATTE TIN LEAD ON SOLDER TAIL, ALL OVER .000050 NICKEL
 △ POSTS: .000030 GOLD IN CONTACT AREA .000100-.000200 MATTE TIN ON SOLDER TAIL, ALL OVER .000050 NICKEL
 △ OBSOLETE PARTS: OBSOLETE CIS STREAMLINING PER D.RENAUD/D.SINISI

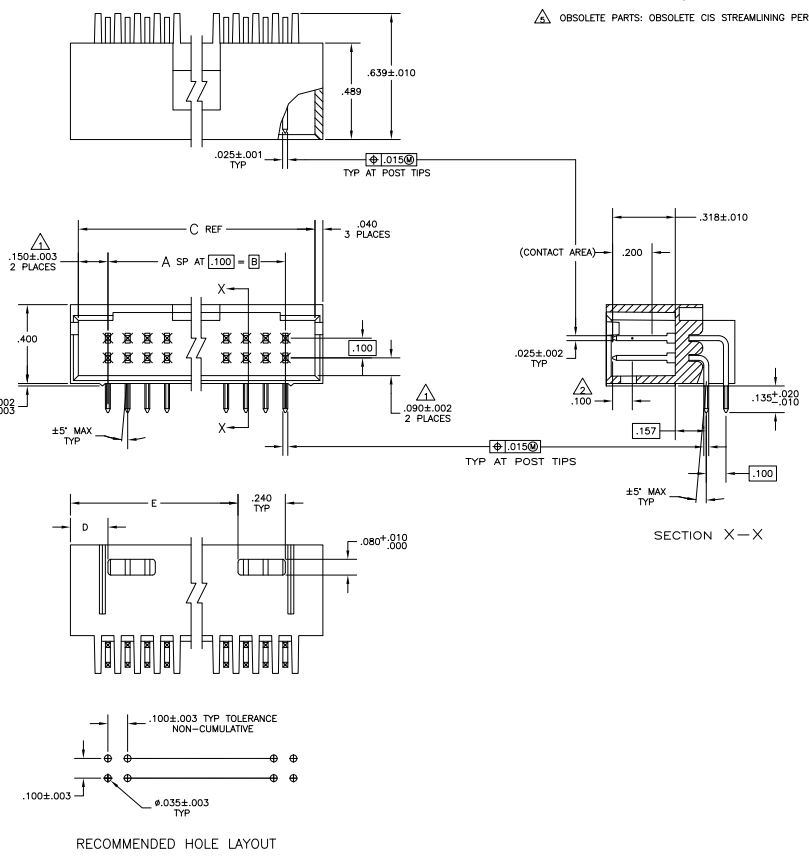

PLATING	E	D	C	B	A	NO OF POSTN	ASSEMBLY PART NUMBER
△ OBSOLETE	△	△	△	△	△	3,490 .190 3.800 3.500 35 72	8-103167-3
△ OBSOLETE	△	△	△	△	△	3,390 .190 3.700 3.400 34 70	8-103167-2
△ OBSOLETE	△	△	△	△	△	3,290 .190 3.600 3.300 33 68	8-103167-1
△ OBSOLETE	△	△	△	△	△	3,190 .190 3.500 3.200 32 66	8-103167-0
△ OBSOLETE	△	△	△	△	△	3,090 .190 3.400 3.100 31 64	7-103167-9
△ OBSOLETE	△	△	△	△	△	2,990 .190 3.300 3.000 30 62	7-103167-8
△ OBSOLETE	△	△	△	△	△	2,890 .190 3.200 2.900 29 60	7-103167-7
△ OBSOLETE	△	△	△	△	△	2,790 .190 3.100 2.800 28 58	7-103167-6
△ OBSOLETE	△	△	△	△	△	2,690 .190 3.000 2.700 27 56	7-103167-5
△ OBSOLETE	△	△	△	△	△	2,590 .190 2.900 2.600 26 54	7-103167-4
△ OBSOLETE	△	△	△	△	△	2,490 .190 2.800 2.500 25 52	7-103167-3
△ OBSOLETE	△	△	△	△	△	2,390 .190 2.700 2.400 24 50	7-103167-2
△ OBSOLETE	△	△	△	△	△	2,290 .190 2.600 2.300 23 48	7-103167-1
△ OBSOLETE	△	△	△	△	△	2,190 .190 2.500 2.200 22 46	7-103167-0
△ OBSOLETE	△	△	△	△	△	2,090 .190 2.400 2.100 21 44	6-103167-9
△ OBSOLETE	△	△	△	△	△	1,990 .190 2.300 2.000 20 42	6-103167-8
△ OBSOLETE	△	△	△	△	△	1,890 .190 2.200 1.900 19 40	6-103167-7
△ OBSOLETE	△	△	△	△	△	1,790 .190 2.100 1.800 18 38	6-103167-6
△ OBSOLETE	△	△	△	△	△	1,690 .190 2.000 1.700 17 36	6-103167-5
△ OBSOLETE	△	△	△	△	△	1,590 .190 1.900 1.600 16 34	6-103167-4
△ OBSOLETE	△	△	△	△	△	1,490 .190 1.800 1.500 15 32	6-103167-3
△ OBSOLETE	△	△	△	△	△	1,390 .190 1.700 1.400 14 30	6-103167-2
△ OBSOLETE	△	△	△	△	△	1,290 .190 1.600 1.300 13 28	6-103167-1
△ OBSOLETE	△	△	△	△	△	1,190 .190 1.500 1.200 12 26	6-103167-0
△	△	△	△	△	△	1,090 .190 1.400 1.100 11 24	5-103167-9
△	△	△	△	△	△	.990 .190 1.300 1.000 10 22	5-103167-8
△	△	△	△	△	△	.890 .190 1.200 .900 9 20	5-103167-7
△	△	△	△	△	△	.790 .190 1.100 .800 8 18	5-103167-6
△	△	△	△	△	△	.690 .190 1.000 .700 7 16	5-103167-5
△	△	△	△	△	△	.590 .900 .600 6 14	5-103167-4
△	△	△	△	△	△	.490 .800 .500 5 12	5-103167-3
△	△	△	△	△	△	.390 .700 .400 4 10	5-103167-2
△	△	△	△	△	△	.290 .600 .300 3 8	5-103167-1
△ OBSOLETE	△	△	△	△	△	3,490 .190 3.800 3.500 35 72	3-103167-3
△ OBSOLETE	△	△	△	△	△	3,390 .190 3.700 3.400 34 70	3-103167-2
△ OBSOLETE	△	△	△	△	△	3,290 .190 3.600 3.300 33 68	3-103167-1
△ OBSOLETE	△	△	△	△	△	3,190 .190 3.500 3.200 32 66	3-103167-0
△ OBSOLETE	△	△	△	△	△	3,090 .190 3.400 3.100 31 64	2-103167-9
△ OBSOLETE	△	△	△	△	△	2,990 .190 3.300 3.000 30 62	2-103167-8
△ OBSOLETE	△	△	△	△	△	2,890 .190 3.200 2.900 29 60	2-103167-7
△ OBSOLETE	△	△	△	△	△	2,790 .190 3.100 2.800 28 58	2-103167-6
△ OBSOLETE	△	△	△	△	△	2,690 .190 3.000 2.700 27 56	2-103167-5
△ OBSOLETE	△	△	△	△	△	2,590 .190 2.900 2.600 26 54	2-103167-4
△ OBSOLETE	△	△	△	△	△	2,490 .190 2.800 2.500 25 52	2-103167-3
△ OBSOLETE	△	△	△	△	△	2,390 .190 2.700 2.400 24 50	2-103167-2
△ OBSOLETE	△	△	△	△	△	2,290 .190 2.600 2.300 23 48	2-103167-1
△ OBSOLETE	△	△	△	△	△	2,190 .190 2.500 2.200 22 46	2-103167-0
△ OBSOLETE	△	△	△	△	△	2,090 .190 2.400 2.100 21 44	1-103167-9
△ OBSOLETE	△	△	△	△	△	1,990 .190 2.300 2.000 20 42	1-103167-8
△ OBSOLETE	△	△	△	△	△	1,890 .190 2.200 1.900 19 40	1-103167-7
△ OBSOLETE	△	△	△	△	△	1,790 .190 2.100 1.800 18 38	1-103167-6
△ OBSOLETE	△	△	△	△	△	1,690 .190 2.000 1.700 17 36	1-103167-5
△ OBSOLETE	△	△	△	△	△	1,590 .190 1.900 1.600 16 34	1-103167-4
△ OBSOLETE	△	△	△	△	△	1,490 .190 1.800 1.500 15 32	1-103167-3
△ OBSOLETE	△	△	△	△	△	1,390 .190 1.700 1.400 14 30	1-103167-2
△ OBSOLETE	△	△	△	△	△	1,290 .190 1.600 1.300 13 28	1-103167-1
△	△	△	△	△	△	1,190 .190 1.500 1.200 12 26	1-103167-0
△	△	△	△	△	△	1,090 .190 1.400 1.100 11 24	103167-9
△	△	△	△	△	△	.990 .190 1.300 1.000 10 22	103167-8
△	△	△	△	△	△	.890 .190 1.200 .900 9 20	103167-7
△	△	△	△	△	△	.790 .190 1.100 .800 8 18	103167-6
△	△	△	△	△	△	.690 .190 1.000 .700 7 16	103167-5
△	△	△	△	△	△	.590 .900 .600 6 14	103167-4
△	△	△	△	△	△	.490 .800 .500 5 12	103167-3
△	△	△	△	△	△	.390 .700 .400 4 10	103167-2
△	△	△	△	△	△	.290 .600 .300 3 8	103167-1

THIS DRAWING IS A CONTROLLED DOCUMENT.

TE Connectivity

HDR ASSY, MOD II, SHRROUDED, 4 SIDES, DCL ROW, .100K-100 RIGHT ANGLE, W/.0025 SQ POSTS

REVISED PER ECU-11-004587

DATE: 4-1