

THIS DRAWING IS UNPUBLISHED
 ALL RIGHTS RESERVED

REV	CM	DATE	DESCRIPTION	BY	CHK	APP
00						
01			REVISED PER EDD-11-04820			

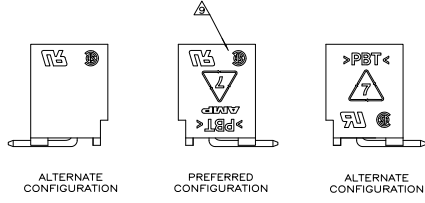
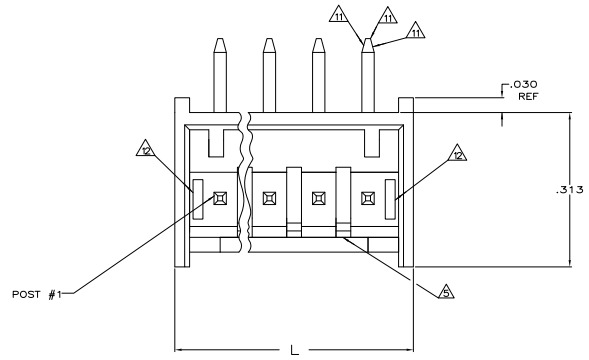

POSSIBLE MARKING CONFIGURATIONS
 SCALE 5:1

- ⚠ MATERIAL: HEADER- POLYESTER UL94V-0 (BLACK)
 POST- COPPER ALLOY.
- ⚠ SOLDER SIDE OF P.C. BOARD SHOWN.
- 3. PARTS COMPLY WITH AMP SOLDERABILITY SPEC 109-11-2.
- ⚠ ONE HOLE MAY BE UNDERSIZED (.032-.035 DIA) FOR ASSEMBLY RETENTION DURING WAVE SOLDERING.
- ⚠ LATCH DETENT FEATURE OCCURS 2 PLACES ON EACH END (MAXIMUM OF FOUR PER PART). FOR 2 THRU 5 CIRCUIT HEADERS, LATCH FEATURE OCCURS BETWEEN EACH CIRCUIT.
- ⚠ COORDINATE DIMENSION APPLIES FROM CENTER OF ACTUAL FEATURE.
- ⚠ POST: 100% MATTE TIN PLATED.
- ⚠ POST MUST WITHSTAND 3.0 LBS (13.3 N) MIN FORCE WITHOUT DISLODGING, EITHER DIRECTION.
- ⚠ UL AND CSA LOGO WILL APPEAR IN THIS AREA. AMP LOGO MAY APPEAR IN THIS AREA OR ON BOTTOM OF PART.
- ⚠ TWO SIDES OF TAPER, AS SHOWN, MUST BE PLATED. TYPICAL, BOTH ENDS.
- ⚠ TWO SIDES OF TAPER, AS SHOWN, AND TIP MAY BE UNPLATED. TYPICAL, BOTH ENDS.
- ⚠ SLOTS MAY OR MAY NOT APPEAR ON THESE PARTS.
- ⚠ POST: MATTE TIN-LEAD (93/7) PLATED.
- ⚠ OBSOLETE PART NUMBER.

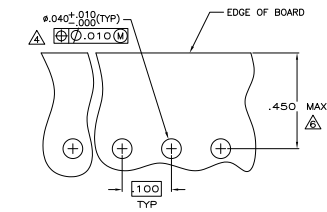
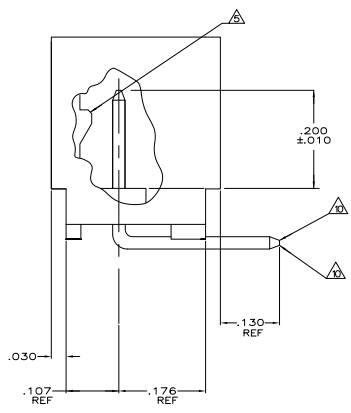
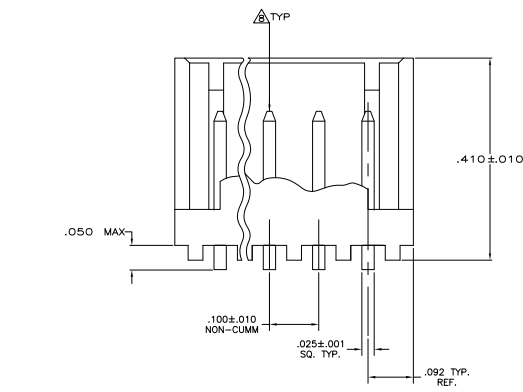

	.035	0.89	.176	4.47	—	—
	.032	0.81	.130	3.3	—	—
	.030	0.76	.107	2.72	—	—
	.025	0.64	.100	2.54	.450	11.43
	.010	0.25	.092	2.34	.410	10.41
	.005	0.13	.063	1.6	.313	7.95
	.001	0.03	.050	1.27	.300	7.62
	.000	0	.040	1.02	.200	5.08
	IN	MM	IN	MM	IN	MM

CONVERSION TABLE

REV	DATE	DESCRIPTION	BY	CHK	APP
1.484	37.69	14	3-644803-4		
1.384	35.15	13	3-644803-3		
1.284	32.61	12	3-644803-2		
1.184	30.07	11	3-644803-1		
1.084	27.53	10	3-644803-0		
.984	24.99	9	2-644803-9		
.884	22.45	8	2-644803-8		
.784	19.91	7	2-644803-7		
.684	17.37	6	2-644803-6		
.584	14.83	5	2-644803-5		
.484	12.29	4	2-644803-4		
.384	9.75	3	2-644803-3		
.284	7.21	2	2-644803-2	YES	7

REV	DATE	DESCRIPTION	BY	CHK	APP
⚠ SUPERSEDED	1.484	37.69	14	1-644803-4	
⚠ SUPERSEDED	1.384	35.15	13	1-644803-3	
⚠ SUPERSEDED	1.284	32.61	12	1-644803-2	
⚠ SUPERSEDED	1.184	30.07	11	1-644803-1	
⚠ SUPERSEDED	1.084	27.53	10	1-644803-0	
⚠ SUPERSEDED	.984	24.99	9	644803-9	
⚠ SUPERSEDED	.884	22.45	8	644803-8	
⚠ SUPERSEDED	.784	19.91	7	644803-7	
⚠ SUPERSEDED	.684	17.37	6	644803-6	
⚠ SUPERSEDED	.584	14.83	5	644803-5	
⚠ SUPERSEDED	.484	12.29	4	644803-4	
⚠ SUPERSEDED	.384	9.75	3	644803-3	
⚠ SUPERSEDED	.284	7.21	2	644803-2	

IN	MM	NO OF POSITIONS	PART NUMBER	LEADFREE	FINISH
L		HEADER ASSEMBLY			

THIS DRAWING IS A CONTROLLED DOCUMENT. METRIC

DATE: 10-11-01 REV: 1

TE Connectivity MTA-100 SHRUGROD HEADER ASSEMBLY, FRICTION LOCK, RIGHT ANGLE POST, TIN OR TIN LEAD PLATED.

SIZE: 100779 G=644803